

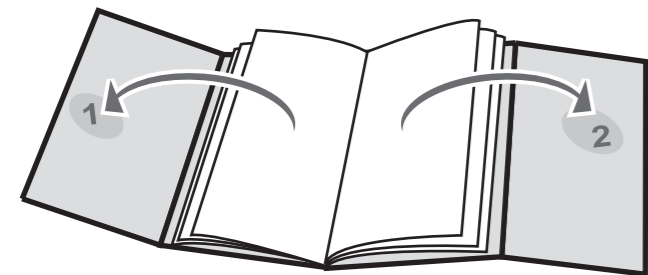

**POWER
TOOLS**



www.sparkygroup.com

142374

1208R01

© 2012 SPARKY



SPARKY

HD PROFESSIONAL

(EN)	TWO-SPEED IMPACT DRILL	1 – 9
	Original instructions	
(DE)	ZWEIGANG-SCHLAGBOHRMASCHINE	10 – 20
	Originalbetriebsanleitung	
(FR)	PERCEUSE A PERCUSSION 2 VITESSES	21 – 30
	Notice originale	
(IT)	TRAPANO BATTENTE A DUE VELOCITÀ	31 – 40
	Istruzioni originali	
(ES)	TALADRADORA DE PERCUSION DE 2 VELOCIDADES	41 – 51
	Instrucciones de uso originales	
(PT)	BERBEQUIM DE PERCUSSÃO DE 2 VELOCIDADES	52 – 62
	Manual original	
(PL)	DWUBIEGOWA WIERTARKA UDAROWA	63 – 72
	Oryginalna instrukcja obsługi	
(RU)	ДВУХСКОРОСТНАЯ ДРЕЛЬ УДАРНОГО ДЕЙСТВИЯ	73 – 83
	Оригинальная инструкция по эксплуатации	
(UK)	ДВОШВИДКІСНИЙ ДРИЛЬ УДАРНОЇ ДІЇ	84 – 94
	Оригінальна інструкція з експлуатації	
(BG)	ДВУСКОРОСТНА УДАРНА БОРМАШИНА	95 – 105
	Оригинална инструкция за използване	

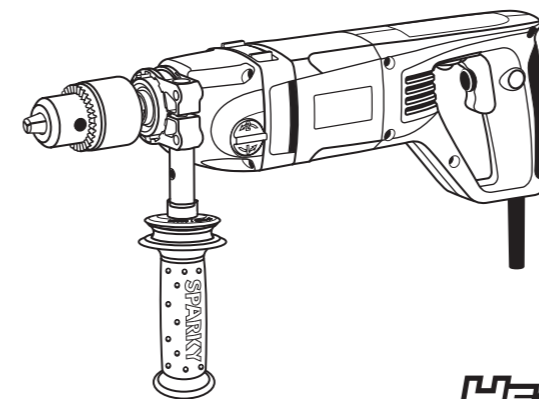

HEAVYDUTY

1260 W

SKU 23802-39624 BUR2 355CE



(EN)

DECLARATION OF CONFORMITY

We declare under our sole responsibility that this product fulfils all the relevant provisions of the following directives and the harmonized standards:
2006/42/EC, 2004/108/EC, EN 60745-1, EN 60745-2-1, EN 55014-1, EN 55014-2, EN 61000-3-2, EN 61000-3-3.
Technical file is stored at SPARKY ELTOS AG, Kubrat Str. 9, 5500 Lovetch, Bulgaria.

(DE)

KONFORMITÄTSERKLÄRUNG

Hiermit versichern wir unsere persönliche Haftung, dass dieses Erzeugnis allen einschlägigen Bestimmungen folgender Richtlinien und entsprechender harmonisierten Standards entspricht:
2006/42/EC, 2004/108/EC, EN 60745-1, EN 60745-2-1, EN 55014-1, EN 55014-2, EN 61000-3-2, EN 61000-3-3.
Die technischen Unterlagen werden bei SPARKY ELTOS AG, Kubrat Str.9, 5500 Lovetch, Bulgarien, aufbewahrt.

(FR)

DECLARATION DE CONFORMITE

Nous déclarons sous notre responsabilité que ce produit satisfait à l'ensemble des dispositions pertinentes de la présente directives, respectivement aux normes harmonisées:
2006/42/EC, 2004/108/EC, EN 60745-1, EN 60745-2-1, EN 55014-1, EN 55014-2, EN 61000-3-2, EN 61000-3-3.
Le dossier technique est conservé par SPARKY ELTOS AD, 9, rue Kubrat, Lovech, Bulgarie.

(IT)

DICHIARAZIONE DI CONFORMITÀ

Noi dichiariamo sotto la nostra personale responsabilità, che questo prodotto è in conformità a tutte le disposizioni pertinenti della presente direttive e norme armonizzate:
2006/42/EC, 2004/108/EC, EN 60745-1, EN 60745-2-1, EN 55014-1, EN 55014-2, EN 61000-3-2, EN 61000-3-3.
Il fascicolo tecnico viene custodito presso la SPARKY ELTOS AD, 5500 Lovech, via Kubrat n. 9, Bulgaria.

(ES)

DECLARACIÓN DE CONFORMIDAD

Declaramos bajo nuestra exclusiva responsabilidad que este producto está conforme con todas las disposiciones aplicables de la presente directrices aplicables y las correspondientes normas armonizadas:
2006/42/EC, 2004/108/EC, EN 60745-1, EN 60745-2-1, EN 55014-1, EN 55014-2, EN 61000-3-2, EN 61000-3-3.
El expediente técnico está archivado en SPARKY ELTOS SA, C/ Kubrat, 9, 5500 Lovech, Bulgaria.

(PT)

DECLARAÇÃO DE CONFORMIDADE

Declaramos assumindo a nossa responsabilidade pessoal que este produto está conforme com todas as disposições relevantes da presente directrizes aplicáveis e respectivos estandartes harmonizados:
2006/42/EC, 2004/108/EC, EN 60745-1, EN 60745-2-1, EN 55014-1, EN 55014-2, EN 61000-3-2, EN 61000-3-3.
A documentação técnica guarda-se no SPARKY ELTOS AD, rua Kubrat 9, 5500, Lovech, Bulgária.

(PL)

DEKLARACJA ZGODNOŚCI

Niniejszym deklarujemy naszą osobistą odpowiedzialnością, że ten produkt spełnia wszystkie odpowiednie postanowienia następujących dyrektyw i harmonizowanych standardów:
2006/42/EC, 2004/108/EC, EN 60745-1, EN 60745-2-1, EN 55014-1, EN 55014-2, EN 61000-3-2, EN 61000-3-3.
Teczka techniczna przechowywana jest w SPARKY ELTOS AG, Kubrat Str.9, 5500 Lovetch, Bulgaria.

(RU)

ДЕКЛАРАЦИЯ О СООТВЕТСТВИИ

Мы заявляем со всей ответственностью, что данный продукт полностью соответствует всем соответствующим требованиям действующих директив и гармонизированных стандартов:
2006/42/EC, 2004/108/EC, EN 60745-1, EN 60745-2-1, EN 55014-1, EN 55014-2, EN 61000-3-2, EN 61000-3-3.
Техническое досье хранится в СПАРКИ ЕЛТОС АД, ул. Кубрат №9, 5500 Ловеч, Болгария.

(UK)

ДЕКЛАРАЦІЯ ПРО ВІДПОВІДНІСТЬ

Ми заявляємо під свою власну відповідальність, що даний продукт відповідає всім діючим вимогам директив і гармонізованих стандартів:
2006/42/EC, 2004/108/EC, EN 60745-1, EN 60745-2-1, EN 55014-1, EN 55014-2, EN 61000-3-2, EN 61000-3-3.
Технічне досьє зберігається в СПАРКИ ЕЛТОС АД, ул. Кубрат № 9, 5500 Ловеч, Болгарія.

(BG)

ДЕКЛАРАЦИЯ ЗА СЪОТВЕТСТВИЕ

Ние декларираме на своя лична отговорност, че това изделие отговаря на всички приложими изисквания на следните директиви и хармонизирани стандарти:
2006/42/EC, 2004/108/EC, EN 60745-1, EN 60745-2-1, EN 55014-1, EN 55014-2, EN 61000-3-2, EN 61000-3-3.
Техническото досье се съхранява в СПАРКИ ЕЛТОС АД, ул. Кубрат №9, 5500 Ловеч, България.

Manufacturer
SPARKY Power Tools GmbH
Leipziger Str. 20
10117 Berlin, GERMANY

Signature of authorized person

A. Ivanov
Technical director of SPARKY ELTOS AG

20.06.2011

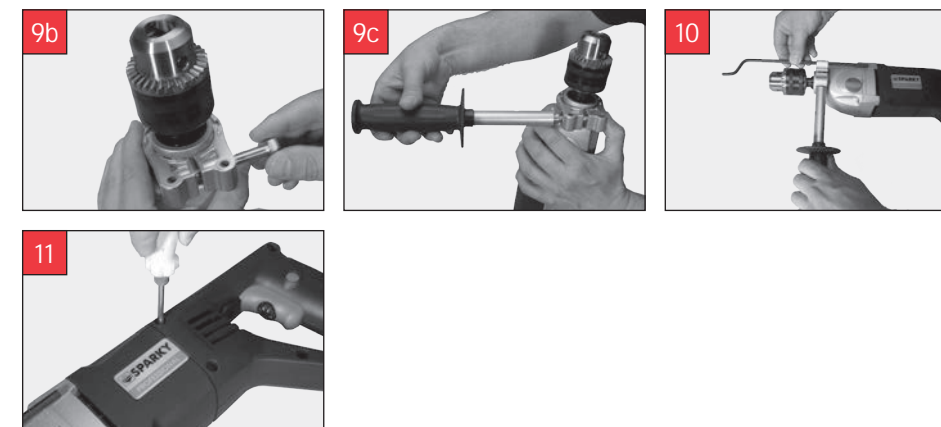
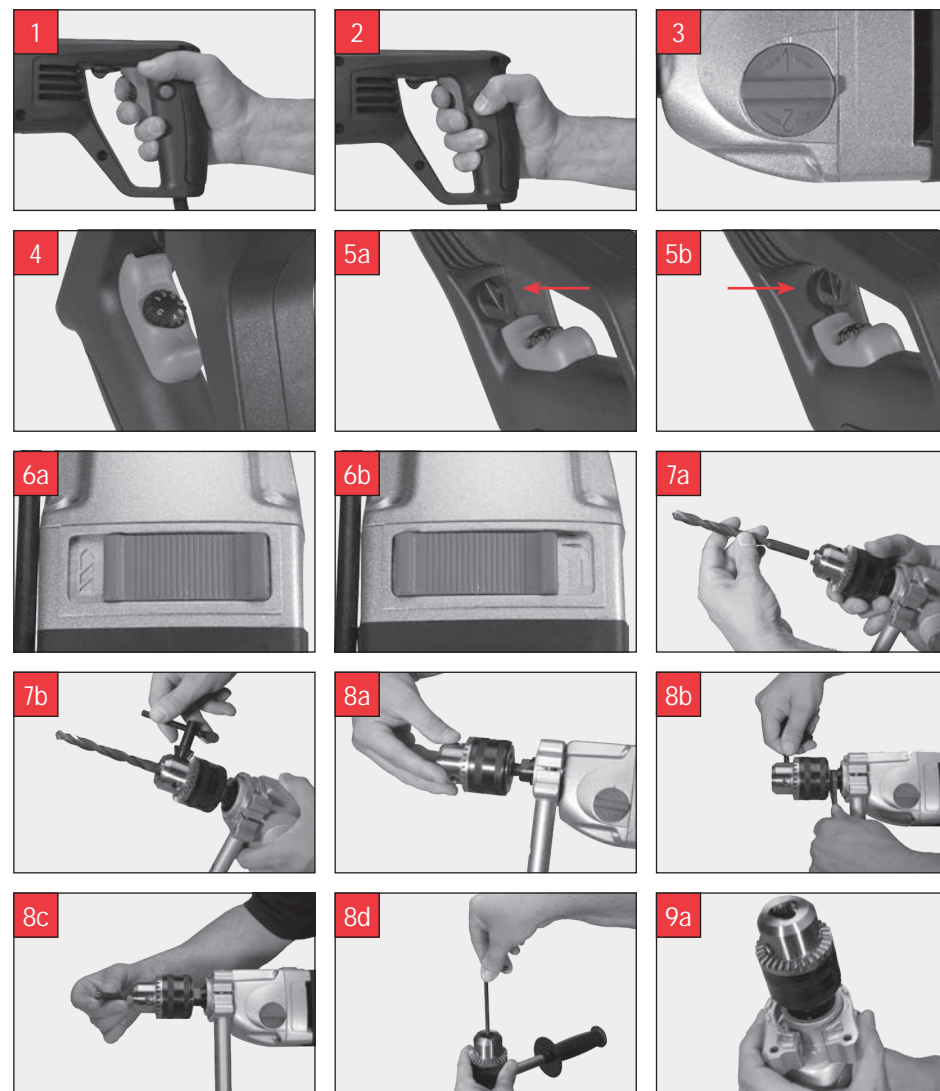
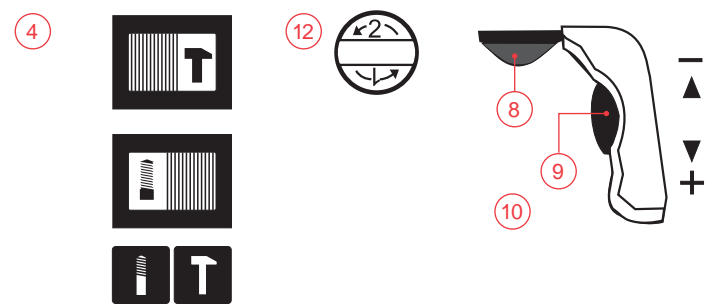
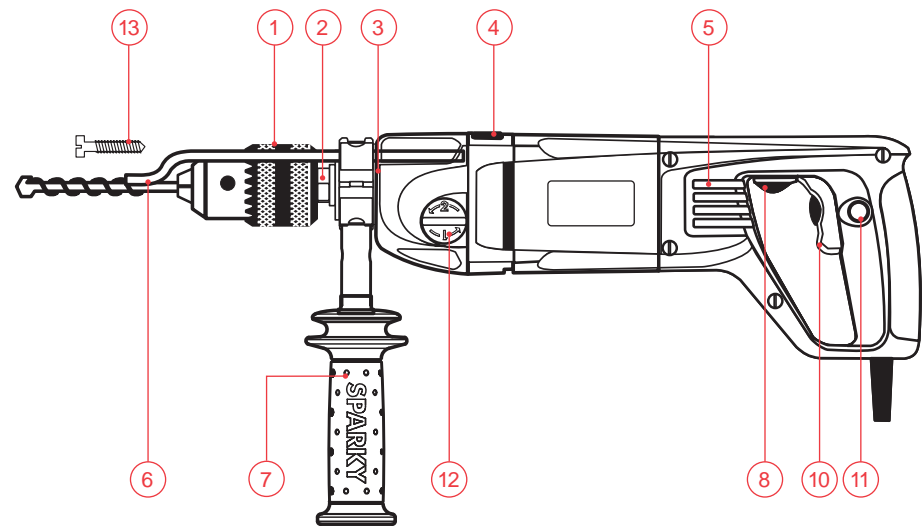

Contents

I - Introduction	1
II - Technical specifications	3
III - General power tool safety warnings	4
IV - Impact drill safety warnings	5
V - Know your product	A/6
VI - Operation	B/C/6
VII - Maintenance	9
VIII - Warranty	9

UNPACKING

Due to modern mass production techniques, it is unlikely that your power tool is faulty or that a part is missing. If you find anything wrong, do not operate the tool until the parts have been replaced or the fault has been rectified. Failure to do so could result in serious personal injury.

ASSEMBLY

The drill, packed in a case, is fully assembled.

The drill, packed in a box, is assembled except for the auxiliary handle.

I - Introduction

Your new SPARKY power tool will more than satisfy your expectations. It has been manufactured under stringent SPARKY Quality Standards to meet superior performance criteria. You will find your new tool easy and safe to operate, and, with proper care, it will give you many years of dependable service.

WARNING:



Carefully read through this entire Original Instructions before using your new SPARKY power tool. Take special care to heed the Warnings. Your SPARKY power tool has many features that will make your job faster and easier. Safety, performance, and dependability have been given top priority in the development of this tool, making it easy to maintain and operate.



Do not dispose of electric tools together with household waste!

Waste electrical products should not be disposed of with household waste. Please recycle where facilities exist. Check with your local authority or retailer for recycling advice.

ENVIRONMENTAL PROTECTION



The machine, accessories and packaging should be sorted for environmental-friendly recycling.

The plastic components are labelled for categorised recycling.

DESCRIPTION OF SYMBOLS

The rating plate on your power tool may show symbols. These represent important information about the product or instructions on its use.



Double insulated for additional protection.



Conforms to the relevant European Directives.



Conforms to the requirements of Russian standards.



Conforms to the requirements of Ukrainian standards.



Refer to Original Instructions.

YYYY-Www Production period, where the variable symbols are:
YYYY- year of manufacture,
Www - calendar week number.

BUR2 Two-speed impact drill.

II - Technical specifications

Model	BUR2 350E plus	BUR2 355CE
Power input	1100W	1260 W
No load speed	0-800/0-2000 min ⁻¹	0-800/0-2000 min ⁻¹
Variable speed	yes	yes
Reversing	yes	yes
Protective clutch	yes	yes
Rated torque		
1st speed	10.7 N.m	11.0 N.m
2nd speed	4.5 N.m	4.3 N.m
Chuck capacity	3-16 mm	3-16 mm
Drilling capacity in:		
Steel	16/10 mm	16/10 mm
Wood	45/20 mm	45/20 mm
Concrete	16/10mm	16/10mm
Weight (EPTA Procedure 01/2003)	3.9 kg	4.1 kg
Protection class (EN 60745-1) 	II	II

NOISE AND VIBRATION INFORMATION

Measured values determined according to EN 60745

Noise emission

A-weighted sound pressure level L_{pA}	97 dB(A)	97 dB(A)
Uncertainty K_{pA}	3 dB	3 dB
A-weighted sound power level L_{WA}	108 dB(A)	108 dB(A)
Uncertainty K_{WA}	3 dB	3 dB

Wear hearing protection!

Vibration emission *

Total vibration values (vector sum in the three axes) determined according to EN 60745:

Impact drilling in concrete		
Vibration emission value $a_{h,ID}$	20.0 m/s ²	20.0 m/s ²
Uncertainty K_{ID}	1.5 m/s ²	1.5 m/s ²
Drilling in metal		
Vibration emission value $a_{h,D}$	6.5 m/s ²	6.0 m/s ²
Uncertainty K_D	1.8 m/s ²	1.8 m/s ²
Drilling with core bits in concrete		
Vibration emission value $a_{h,DD}$	11.0 m/s ²	11.0 m/s ²
Uncertainty K_{DD}	1.5 m/s ²	1.5 m/s ²

* The vibration emission values are determined according to 6.2.7 EN 60745-1.

The vibration emission level given in this information sheet has been measured in accordance with a standardised test given in EN 60745 and may be used to compare one tool with another. It may be used for a preliminary assessment of exposure.

The declared vibration emission level represents the main applications of the tool. However if the tool is used for different applications, with different accessories or poorly maintained, the vibration emission may differ. This may significantly increase the exposure level over the total working period.

An estimation of the level of exposure to vibration should also take into account the times when the tool is switched off or when it is running but not actually doing the job. This may significantly reduce the exposure level over the total working period.

Maintain the power tool and the accessories and keep your hands warm during operation to reduce the harmful effect of vibrations.

Dust from material such as paint containing lead, some wood species, minerals and metal may be harmful. Contact with or inhalation of the dust may cause allergic reactions and/or respiratory diseases to the operator or bystanders.

Certain kinds of dust are classified as carcinogenic such as oak and beech dust especially in conjunction with additives for wood conditioning (chromate, wood preservative). Material containing asbestos must only be treated by specialists.

- Where the use of a dust extraction device is possible it shall be used.
- The work place must be well ventilated.
- The use of a dust mask of filter class P2 is recommended.

Follow national requirements for the materials you want to work with.

III - General power tool safety warnings



WARNING! Read all safety warnings and all instructions. Failure to follow the warnings and instructions may result in electric shock, fire and/or serious injury.

Save all warnings and instructions for future reference.

The term "power tool" in the warnings refers to your mains-operated (corded) power tool or battery-operated (cordless) power tool.

1) Work area safety

- Keep work area clean and well lit.** Cluttered or dark areas invite accidents.
- Do not operate power tools in explosive atmospheres, such as in the presence of flammable liquids, gases or dust.** Power tools create sparks which may ignite the dust or fumes.
- Keep children and bystanders away while operating a power tool.** Distractions can cause you to lose control.

2) Electrical safety

- Power tool plugs must match the outlet. Never modify the plug in any way. Do not use any adapter plugs with earthed (grounded) power tools.** Unmodified plugs and matching outlets will reduce risk of electric shock.
- Avoid body contact with earthed or grounded surfaces, such as pipes, radiators, ranges and refrigerators.** There is an increased risk of electric shock if your body is earthed or grounded.
- Do not expose power tools to rain or wet conditions.** Water entering a power tool will increase the risk of electric shock.
- Do not abuse the cord. Never use the cord for carrying, pulling or unplugging the power tool. Keep cord away from heat, oil, sharp edges or moving parts.**

Damaged or entangled cords increase the risk of electric shock.

- When operating a power tool outdoors, use an extension cord suitable for outdoor use.** Use of a cord suitable for outdoor use reduces the risk of electric shock.
- If operating a power tool in a damp location is unavoidable, use a residual current device (RCD) protected supply.** Use of an RCD reduces the risk of electric shock.

3) Personal safety

- Stay alert, watch what you are doing and use common sense when operating a power tool. Do not use a power tool while you are tired or under the influence of drugs, alcohol or medication.** A moment of inattention while operating power tools may result in serious personal injury.
- Use personal protective equipment. Always wear eye protection.** Protective equipment such as dust mask, non-skid safety shoes, hard hat, or hearing protection used for appropriate conditions will reduce personal injuries.
- Prevent unintentional starting. Ensure the switch is in the off-position before connecting to power source and/or battery pack, picking up or carrying the tool.** Carrying power tools with your finger on the switch or energising power tools that have the switch on invites accidents.
- Remove any adjusting key or wrench before turning the power tool on.** A wrench or a key left attached to a rotating part of the power tool may result in personal injury.
- Do not overreach. Keep proper footing and balance at all times.** This enables better control of the power tool in unexpected situations.
- Dress properly. Do not wear loose clothing or jewellery. Keep your hair, clothing and gloves away from moving parts.** Loose clothes, jewellery or long hair can be caught in moving parts.

- g) If devices are provided for the connection of dust extraction and collection facilities, ensure these are connected and properly used. *Use of dust collection can reduce dust-related hazards.*
- 4) Power tool use and care**
- Do not force the power tool. Use the correct power tool for your application.** *The correct power tool will do the job better and safer at the rate for which it was designed.*
 - Do not use the power tool if the switch does not turn it on and off.** *Any power tool that cannot be controlled with the switch is dangerous and must be repaired.*
 - Disconnect the plug from the power source and/or the battery pack from the power tool before making any adjustments, changing accessories, or storing power tools.** *Such preventive safety measures reduce the risk of starting the power tool accidentally.*
 - Store idle power tools out of the reach of children and do not allow persons unfamiliar with the power tool or these instructions to operate the power tool.** *Power tools are dangerous in the hands of untrained users.*
 - Maintain power tools. Check for misalignment or binding of moving parts, breakage of parts and any other condition that may affect the power tool's operation. If damaged, have the power tool repaired before use.** *Many accidents are caused by poorly maintained power tools.*
 - Keep cutting tools sharp and clean.** *Properly maintained cutting tools with sharp cutting edges are less likely to bind and are easier to control.*
 - Use the power tool, accessories and tool bits etc. in accordance with these instructions, taking into account the working conditions and the work to be performed.** *Use of the power tool for operations different from those intended could result in a hazardous situation.*
- 5) Service**
- Have your power tool serviced by a qualified repair person using only identical replacement parts.** *This will ensure that the safety of the power tool is maintained.*

IV - Impact drill safety warnings



Wear ear protectors with impact drills.

Exposure to noise can cause hearing loss.

- **Use the auxiliary handle supplied with the machine.** *Loss of control can cause personal injury.*



During operation provide eye protection to prevent eyes from exposure to flying particles. Wear goggles.



Take protective measures against inhalation of dust. Some materials can contain toxic ingredients. *Wear a dust mask and work with dust/chip extraction when connectable.*

- **Hold the power tool by insulated gripping surfaces only, when performing an operation where the cutting accessory may contact hidden wiring or its own cord.** *Cutting accessory contacting a "live" wire may make exposed metal parts of the power tool "live" and could give the operator an electric shock.*
- Do not process materials containing asbestos. Asbestos is considered carcinogenic.



WARNING: Before connecting a tool to a power source be sure that the voltage supply is the same as that specified on the nameplate of the tool.

- A power source with a voltage greater than that specified for the tool can result in serious injury to the user, as well as damage to the tool.
- If in doubt, do not plug in the tool.
- Using a power source with a voltage less than the nameplate rating is harmful to the motor.
- Fully unwind cable drum extensions to avoid potential overheating.
- When an extension cable is required, you must ensure that it has the right ampere rating for your power tool and it is in safe electrical condition.



WARNING: Always switch off and unplug the power tool prior to any adjustment, servicing or maintenance.

- While operating the machine, always hold it firmly with both hands and provide for a secure stance. The power tool is guided more securely with both hands.
- Prior to operation use suitable detectors to determine if utility lines are hidden in the work area or call the local utility company for assistance. Contact with electric lines can lead to fire and electric shock. Damaging a gas line can lead to explosion. Penetrating a water line causes property damage or may cause electric shock.
- Always keep the cord away from the working area of the power tool.
- Never use the machine with a damaged cable. Do not touch the damaged cable and pull the mains plug when the cable is damaged while operating. Damaged cables increase the risk of electric shock.
- Always be sure you have a firm footing. Be sure no one is below when using the tool in high locations.
- Use clamps or a vice to secure your work whenever possible.
- Watch out for the initial torque reaction of the machine or upon jamming the drill bit.
- Do not touch the drill bit or parts close to it during operation and immediately after that; they may be extremely hot. You may get serious burns.
- Keep work area clean. Blends of materials are particularly dangerous. Dust from light alloys can burn or explode.
- Rags, cloths, cord, string and the like should never be left around the work area.
- Always switch the machine off prior to leaving it down.
- The tool must be used only for its prescribed purpose. Any use other than those mentioned in this Manual will be considered a case of misuse. The user and not the manufacturer shall be liable for any damage or injury resulting from such cases of misuse.
- To use this tool properly, you must observe the safety regulations, the assembly instructions and the operating instructions found in this Manual. All persons who use and service the machine have to be acquainted with this Manual and must be informed about its potential hazards. Children and frail people must not

use this tool. Children should be supervised at all times if they are in the area in which the tool is being used. It is also imperative that you observe the accident prevention regulations in force in your area. The same applies for general rules of occupational health and safety.

- The manufacturer shall not be liable for any changes made to the tool nor for any damage resulting from such changes.
- The power tools must not be used outdoors in rainy weather, or in moist environment (after rain) or in close vicinity with easily flammable liquids and gases. The working place should be well lit.

V - Know your product

Before using the power tool, familiarize yourself with all the operating features and safety requirements.

Use the tool and accessories only for the applications intended. All other applications are expressly ruled out.

1. Three-jaw chuck
2. Place for fixing the spindle
3. Drill journal
4. Operation mode selector switch
5. Ventilation slots
6. Depth gauge
7. Auxiliary handle
8. Reversing switch
9. Electronic regulator of rotation speed
10. ON/OFF switch
11. Lock-on button
12. Speed selector switch
13. Securing screw

VI - Operation

This power tool is supplied from single-phase alternating current mains only. It is double insulated according to EN 60745-1 and IEC 60745 and can be connected to grounded or not grounded sockets. This power tool is radio suppressed in compliance with EMC Directive 2004/108/EC.

The machine with mounted proper drill bit is suitable for impact drilling in stone, steel, wood, etc. The machine is not designed for wet diamond drilling in concrete!

PRIOR TO INITIAL OPERATION

- Make sure the power supply voltage corre-

sponds to the value indicated on the name plate with technical data of the tool.

- Always check the position of ON/OFF switch. The power tool must be connected to the power supply socket only when this switch is in OFF position. If the plug is connected to a receptacle while the power switch is in the ON position, the power tool will start operating immediately, which could cause a serious accident.
- Make sure that the cord and the plug are in order. If the replacement of the supply cord is necessary, this has to be done by the manufacturer or his agent in order to avoid a safety hazard.



WARNING: Always switch off and unplug the power tool prior to any adjustment, servicing or maintenance.

- In case the work area is remote from the power source, use as short as practicable extension cord with proper cross-section.
- Check that the auxiliary handle is properly mounted and reliably tightened.



WARNING: Prior to operation always check the direction of rotation. Shift the reversing switch only when the spindle has come to a complete stop. Reversing prior to final spindle halt may damage the power tool.

SWITCHING ON - SWITCHING OFF

Brief activation

- Switching on: Press ON/OFF switch 10. (Fig. 1)
- Switching off: Release ON/OFF switch 10.

Continuous operation

- Switching on: Press ON/OFF switch 10 and in pressed position lock it by button 11. (Fig. 2)
- Switching off: Press ON/OFF switch 10 once and release it immediately.

TWO-SPEED SELECTOR SWITCH

Rotate switch 12 to 180° clockwise or counter-clockwise, in order to select one or the other speed range. The direction of rotation for switching is shown on the switch. (Fig. 3)

TRIGGER SPEED CONTROL

Set the maximum speed necessary by rotating

thumbwheel 9 in position A - G. Position A corresponds to minimum rpm, position G - to maximum rpm.

Light pressure on ON/OFF switch 10 results in low rotation speed, further pressing the trigger results in smooth increase of the rpm to the pre-selected maximum by thumbwheel 9 upon reaching the extreme position. (Fig. 4)

REVERSING

The extreme position of lever 8 to the right (Fig. 5a) is equivalent to clockwise rotation, the extreme position to the left - to anti-clockwise rotation (Fig. 5b). When ON/OFF switch 10 is depressed lever 8 can not be actuated. Reversing can be performed only when the spindle is not rotating!



WARNING: Do not overload the machine while operating it at left run. There is a danger of tearing the securing screw and unwinding the chuck.

OPERATION MODE SELECTION

- Drilling in metal, wood, etc. The switch 4 is in its extreme right position the symbol "drill bit" being exposed. (Fig. 6a)
- Drilling in concrete, stone, etc. The ON/OFF switch 4 is in its extreme left position and the symbol "hammer" is exposed. (Fig. 6b)

Switching the operation modes can be performed while the machine is operated.

INSERTING AND FASTENING DRILL BITS

Through turning the collar of the chuck 1 clockwise or counter-clockwise the jaws are positioned so the drill bit shank can be inserted inside the choke (Fig. 7a). By turning the collar of chuck 1 counter-clockwise (looking towards the chuck) the jaws tighten the drill bit shank. Fix the drill bit finally in the chuck by means of the chuck key, tightening equally in all three bores (Fig. 7b).

PROTECTIVE CLUTCH

The machine is equipped with protective clutch. An audible click is heard upon actuating the clutch and the spindle halts or barely rotates.



WARNING: The reactive torque upon actuating the protective clutch provokes considerable strain on the operator's hands. The reactive torque is overcome mainly by the auxiliary handle. The strain on the operator's hand holding the auxiliary handle is considerable and amounts to 250 N (25 kg). Therefore the grip on the auxiliary and the back handle should be firm. To ensure more reliable grip we recommend perpendicular orientation of the auxiliary handle towards the back handle during assembly.

To achieve extended durability and reliability of the protective clutch, decrease the load after clutch actuation. Upon this event the clutch will return to its normal position (the specific noise will disappear) and the operator can resume work.



WARNING: Use only drill bits with proper diameter, not exceeding the specified on the name plate for the corresponding speed, to avoid excessive actuating the protective clutch.

CURRENT OVERLOAD PROTECTION

The machine is equipped with an electronic module ensuring safety against overload. Upon actuation of this device the spindle stops to rotate. To resume normal operation, first switch off and then switch on the ON/OFF switch.

MOUNTING AND DISMOUNTING THE CHUCK

Mounting the chuck

Wind up chuck 1 onto the spindle completely (Fig. 8a). Grip the spindle with S17 open-end spanner on place 2. Insert the chuck key in one of the three bores and fasten the chuck using the key as a lever (Fig. 8b). Open the chuck 1 jaws completely, place the left threaded securing screw (Fig. 8c) and fasten it by S5 hex bit (Fig. 8d).

Dismounting the chuck

Open the chuck jaws completely. Unscrew the left threaded securing screw using S5 hex bit. Grip the spindle with S17 open-end spanner on place 2. Insert the chuck key in one of the three bores and rotating clockwise (looking forward

to the chuck) using the key as lever, unwind chuck 1 from the spindle.

AUXILIARY HANDLE

Tighten the auxiliary handle onto the drill journal 3. The auxiliary handle bracelet shall lean against the support surface of the machine journal (Fig. 9a), with the five journal teeth engaged in the bracelet grooves of the auxiliary handle (Fig. 9b). The bracelet shall be firmly fastened to the machine journal (Fig. 9c). The depth gauge 6 can be used for fixing the depth of drilled bores (Fig. 10).



WARNING: In the interests of safety, the auxiliary handle 7 should always be used!

RECOMMENDATIONS FOR OPERATION

DRILLING IN CONCRETE WITH DRILL BITS

Apply moderate pressure during drilling in concrete (approximately 100-120 N. Higher pressure will not increase drilling efficiency, but it will lead to decreasing the operation life of the machine. Drill with speed lower than the maximum, suited to the material.

Use carbide tipped straight shank drill bits. Take the drill out of the opening from time to time to remove dust.



WARNING: Watch out for the stage of blunting of the bit and change it if considerable decrease of efficiency is observed.

The optimum capacity when drilling in concrete is up to 10 mm.

ACCESSORIES TO BE USED WITH THIS POWER TOOL

- Drill bits for steel $\varnothing 3$ mm to $\varnothing 16$ mm
- Drill bits for wood $\varnothing 3$ to $\varnothing 45$ mm
- Drill bits for concrete $\varnothing 3$ to $\varnothing 16$ mm

VII - Maintenance



WARNING: Always ensure that the tool is switched off and unplugged before attempting to perform inspection or maintenance.

BRUSH REPLACEMENT

This power tool is equipped with auto-stop brushes. When the carbon brushes are worn out, the machine switches itself off. In this case both brushes must be replaced simultaneously with genuine brushes at SPARKY service centre for warranty and post-warranty service.

GENERAL INSPECTION

Regularly inspect all fasteners and ensure they are properly tightened. Should any of the screws be loose, retighten it immediately to avoid hazards (Fig. 11).

If the replacement of the supply cord is necessary, this has to be done by the manufacturer or his agent in order to avoid a safety hazard.

CLEANING

For safe operation always keep the machine and its ventilation slots clean.

Regularly check to see if any dust or foreign matter has entered the ventilation slots and the grills around the switches. Use a soft brush and/or air jet to remove any accumulated dust. Wear safety glasses to protect your eyes whilst cleaning.

Exterior plastic parts may be cleaned with a damp cloth and mild detergent if necessary.



WARNING: Never use alcohol, petrol or other cleaning agent. Never use caustic agents to clean plastic parts.



WARNING: Water must never come into contact with the tool.

IMPORTANT! To assure product safety and reliability, repairs, maintenance and adjustment (including brush inspection and replacement) should be performed by certified service centres or other qualified service organisations, always using genuine replacement parts.

VIII - Warranty

The guarantee period for SPARKY power tools is determined in the guarantee card.

Faults due to normal wear, overloading or improper handling will be excluded from the guarantee.

Faults due to defective materials implemented as well as defects in workmanship will be corrected free of charge through replacement or repair.

The complaints for defective SPARKY power tools will be recognized if the machine is sent back to the dealer or is presented to the authorised warranty service centre undismantled, in its initial condition.

Notes

Carefully read the entire Instruction Manual before using this product.

The manufacturer reserves the right to make changes and improvements to the products and to alter specifications without prior notice.

Specifications may differ from country to country.

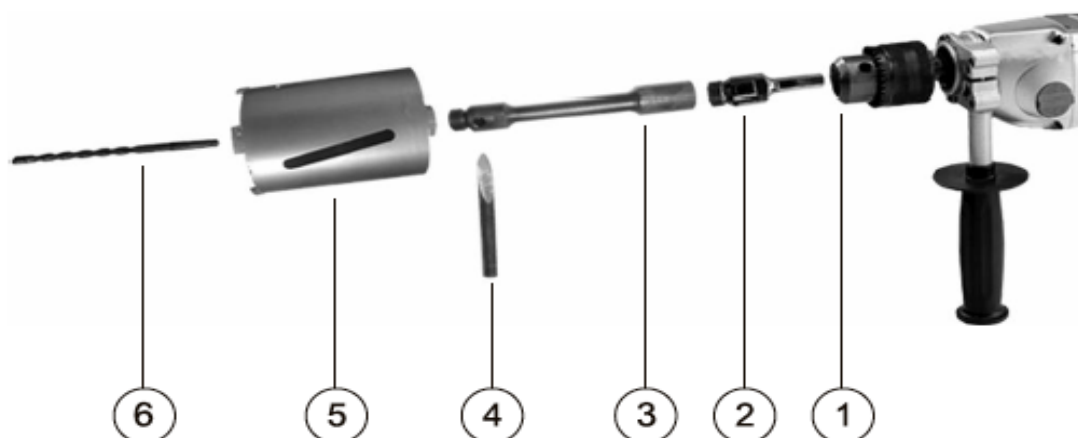

EN

1. Chuck
2. Adapter
3. Extension rod
4. Drift key
5. Core bit
6. Pilot drill bit

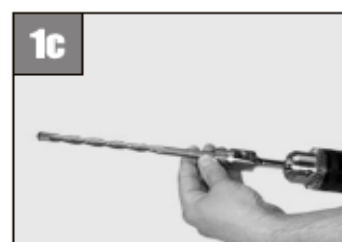

RECOMMENDATIONS FOR DRILLING WITH DIAMOND CORE BITS

INSERTING AND FASTENING OF CORE BITS

Assembling or disassembling the core bit can be performed only if the machine is unplugged!

By turning the collar of the chuck 1 clockwise or counter-clockwise the jaws are positioned so that the adapter shank 2 can be inserted inside the choke, taking heed the chuck three tightening teeth grip three of the adapter shank flat surfaces (Fig. 1a). By rotating the chuck collar 1 counter-clockwise (looking towards the chuck) the jaws tighten the adapter shank 2. Fix the adapter finally in the chuck by means of the chuck key, tightening equally in all three bores (Fig. 1b). Insert the pilot bit 6 in the conic opening of the adapter 2 (Fig. 1c). Place and screw the core bit 5 onto the mounted adapter (Fig. 1d). To disassemble the pilot bit 6 insert the drift key 4 into the adapter opening and remove pilot bit by slightly knocking on the drift key (Fig. 1e).

To drill holes deeper than the core bit 5 length, use the extension rod 3. For this purpose unwind the core bit from the adapter and remove the pilot bit. Screw the extension rod 3 onto the adapter (Fig. 2a) and then place the core bit (Fig. 2b). If necessary, place the pilot bit 6 into the extension rod conic opening (Fig. 2c).

DRILLING WITH DIAMOND CORE BITS

This machine can be used for dry drilling with diamond core bits with diameter from Ø28 mm to Ø152 mm.

Dry diamond cores offer an effective method of drilling through soft abrasive materials such as facing bricks, soft concrete blocks, breezeblocks and soft stone(except for limestone). They should not be used to drill through site cast concrete or hard bricks such as engineering brick. All diamond tools need some form of cooling to stop overheating. Dry diamond cores rely on the air flow to disperse heat.

When operating with such tools please observe the following recommendations:

- Grip the machine firmly with both hands.
- Ensure the machine is set to rotary mode only - the symbol "drill bit" on switch 4 being exposed.
- Set the machine to 1st gear - low speed, high torque.
- To increase efficiency upon reaching 10-15mm depth take the pilot drill out, insert the core bit into the bored channel and switch the machine on to rotate the core bit slowly.
- Holes which do not have to be applied exactly can be drilled without a pilot bit. For this purpose apply the core bit slantwise into the material and upon reaching 5 mm depth straighten the machine (This is possible when using short core bits only.)
- Take the core bit out of the hole at regular intervals to reduce the core bit temperature - rotating the core bit outside the hole for a couple of seconds will provide heat dispersion. If pieces from the processed material break in the hole, take the core bit out and remove the pieces.
- If drilling is slow and/or the core bit gets too hot (starts to sparkle) decrease the rotation speed. **DO NOT INCREASE PRESSURE!**
- A sharpened core bit facilitates operation and faster drilling. To sharpen the core bit use silicate brick or sharpening plate.