

# evOLUTION®

www.evolutionpowertools.com

## RAGE 6

Original Instructions



The logo for 'evolution' features the word in a bold, lowercase, sans-serif font. A grey, curved swoosh is positioned above the 'e' and 'v', extending from the top of the 'e' to the top of the 'v'. A registered trademark symbol (®) is located at the top right of the word.

**evolution<sup>®</sup>**

# ENGLISH

Original Instructions

EN

FR

IT

NL

**TABLE OF CONTENTS**

English	Page 4
Français	Page 30
Italiano	Pagina 60
Nederlands	Pagina 90
<b>Important Information</b>	
Warranty	Page 5
Specification	Page 6
Labels & Symbols	Page 7
General Safety Rules	Page 8
Additional Specific Safety Rules	Page 9
Machine Overview	Page 12
Service Parts Diagram	Page 14
Operation Mitre Saw	Page 15
Operation Table Saw	Page 21
Maintenance	Page 25
Environmental Protection	Page 27
EC - Declaration of Conformity	Page 28

## **IMPORTANT**

**Please read these operating and safety instructions carefully and completely. For your own safety, if you are uncertain about any aspect of using this equipment please access the relevant Technical Helpline, the number of which can be found on the Evolution Power Tools website. We operate several Helplines throughout our worldwide organization, but Technical help is also available from your supplier.**

### **WEB**

[www.evolutionpowertools.com/register](http://www.evolutionpowertools.com/register)

### **EMAIL**

[info@evolutionpowertools.com](mailto:info@evolutionpowertools.com)

**Congratulations on your purchase of an Evolution Power Tools Machine. Please complete your product registration 'online' as explained in the A4 online guarantee registration leaflet included with this machine. You can also scan the QR code found on the A4 leaflet with a Smart Phone. This will enable you to validate your machine's guarantee period via Evolutions website by entering your details and thus ensure prompt service if ever needed. We sincerely thank you for selecting a product from Evolution Power Tools.**

## **EVOLUTION LIMITED GUARANTEE**

**Evolution Power Tools reserves the right to make improvements and modifications to the product design without prior notice. Please refer to the guarantee registration leaflet and/or the packaging for details of the terms and conditions of the guarantee.**

Evolution Power Tools will, within the guarantee period, and from the original date of purchase, repair or replace any goods found to be defective in materials or workmanship. This guarantee is void if the tool being returned has been used beyond the recommendations in the Instruction Manual or if the machine has been damaged by accident, neglect, or improper service.

This guarantee does not apply to machines and / or components which have been altered, changed, or modified in any way, or subjected to use beyond recommended capacities and specifications. Electrical components are subject to respective manufacturers' warranties. All goods returned defective shall be returned prepaid freight to Evolution Power Tools. Evolution Power Tools reserves the right to optionally repair or replace it with the same or equivalent item.







There is no warranty – written or verbal – for consumable accessories such as (following list not exhaustive) blades, cutters, drills, chisels or paddles etc. In no event shall Evolution Power Tools be liable for loss or damage resulting directly or indirectly from the use of our merchandise or from any other cause. Evolution Power Tools is not liable for any costs incurred on such goods or consequential damages. No officer, employee or agent of Evolution Power Tools is authorized to make oral representations of fitness or to waive any of the foregoing terms of sale and none shall be binding on Evolution Power Tools.

Questions relating to this limited guarantee should be directed to the company's head office, or call the appropriate Helpline number.

## SPECIFICATIONS

DESCRIPTION	METRIC	IMPERIAL
Motor (UK/EU) 230V-240V ~ 50Hz	1000W	5A
Motor (UK) 110V ~ 50Hz	1000W	9A
Speed (No Load)	2500rpm	2500min <sup>-1</sup>
Weight	18kg	40lb
MITRE SAW MODE - MAXIMUM CUTTING		
Mild Steel	6mm	1/4"
Wood - 90° Mitre x 90° Bevel	150 x 70mm	5-7/8 x 2-3/4"
Wood - 45° Mitre x 45° Bevel	50 x 50mm	2 x 2"
TABLE SAW MODE - MAXIMUM CUTTING		
Mild Steel	6mm	1/4"
Wood	40mm	1-1/2"
Table Dimensions	570 x 450mm	22-1/2 x 17-3/4"
BLADE		
Diameter	255mm	10"
Number Of Teeth	28	28
Bore Diameter	25.4mm	1"
Kerf	2mm	.078"
Max Speed	2750min <sup>-1</sup>	2750rpm
NOISE & VIBRATION DATA		
Sound Pressure Level L <sub>p</sub> A	106.3dB(A) K=3dB(A)	
Sound Power Level L <sup>w</sup> A	119.3dB(A) K=3dB(A)	
Vibration Level	2.5 m/s <sup>2</sup> K=1.5dB(A)	

## LABELS & SYMBOLS

Symbol	Description
V	Volts
A	Amperes
Hz	Hertz
Min <sup>-1</sup>	Speed
~	Alternating current
n <sub>0</sub>	No load speed
	Wear safety goggles
	Wear ear protection
	Do not touch
	Wear dust protection
	CE certification
	Waste electrical and electronic equipment

**WARNING:** Do not operate machine if warning and / or instruction labels are missing or damaged. Contact Evolution Power Tools for replacement labels.

Only use genuine Evolution replacement saw blades. Unauthorized blades may be dangerous! Keep saw blades securely fastened. Check the blade flanges for debris before installing any new blade. Do not use dull, broken or damaged blades. Check the blade regularly for condition and wear. A damaged or worn blade should be replaced immediately. Beware of ejecting chips as they may be HOT. Always make provision for the safe handling of excess material. Keep machine base and rotary table free from dirt and other debris.

### VIBRATION LEVEL

The declared vibration total value has been measured in accordance with a standard test method and may be used for comparing one tool with another.

The declared vibration total value may also be used in a preliminary assessment of exposure.

**WARNING:** The vibration emission during actual use of the power tool can differ from the declared total value depending on the ways in which the tool is used. The need to identify safety measures and to protect the operator are based on an estimation of exposure in the actual conditions of use (taking account of all parts of the operating cycle, such as the times the tool is switched off, when it is running idle, in addition to trigger time).

To obtain an additional copy of your manual, please contact Evolution Power Tools at:

**UK: +44 (0)114 251 1022**

**WEB: [www.evolutionpowertools.com](http://www.evolutionpowertools.com)**

EN

FR

IT

NL

## IMPORTANT SAFETY INSTRUCTIONS

To reduce the risk of electric shock, this equipment is fitted with an approved cord and plug for its intended country of use. Do not change the cord or plug in any way.

## GENERAL SAFETY RULES

Read and understand all instructions before operating this product. Failure to follow all instructions listed below may result in electric shock, fire and / or serious personal injury.

## SAVE THESE INSTRUCTIONS FOR FUTURE REFERENCE.

The term "power tool" in the warnings refers to your mains-operated (corded) power tool or battery-operated (cordless) power tool.

**WARNING:** When using electric tools, basic safety precautions should always be followed to reduce the risk of fire, electric shock and personal injury.

Please read all of these instructions before attempting to operate this machine. Save this manual for future reference.

- 1) Keep work area clear.** Cluttered work areas invite accidents.
- 2) Consider work area environment.** Do not expose tools to rain. Do not use tools in damp or wet locations. Keep work area well lit. Never use tools near flammable liquids or gases.
- 3) Protect yourself against electric shock.** Avoid body contact with earthed or grounded surfaces.
- 4) Keep other people away.** Do not let others, especially children, come close to the work, and touch the tool or the extension lead. Keep them away from the work area.
- 5) Store idle tools.** When not in use, tools should be stored in a dry locked-up place, out of children's reach.
- 6) Never force the tools.** Your tools will be more efficient and safer when used at the rate for which they were intended.

**7) Use the right tool.** Do not force small tools to do the job of a heavy duty tool. Do not use tools for purposes not intended; for example do not use circular saws to cut tree limbs or logs.

**8) Dress properly.** Do not wear loose clothing or jewellery which may get caught in moving parts. Non-skid footwear is recommended when working outdoors. If you have long hair, tie it back and wear protective hair covering.

**9) Use protective equipment.** Use safety glasses. Use face or dust mask if cutting operations create dust.

**10) Connect dust extraction equipment.** If the machines have a connection for dust extraction equipment, ensure these are connected and properly used.

**11) Do not damage the cable.** Never pull the power cable to disconnect the machine. Keep the cable away from heat, oil and sharp edges.

**12) Secure workpiece.** Where possible, use clamps or a vice to hold the workpiece. It's much safer than using your hands.

**13) Don't over reach.** Keep proper footing and balance at all times.

**14) Maintain tools in good working condition.** Keep cutting tools sharp and clean for better performance and optimum safety. Follow instructions for lubricating and changing accessories. Inspect power cables regularly and, if damaged, have them replaced by an authorised service centre. Inspect extension cables regularly and replace immediately if damaged. Keep handles dry, clean and free from oil and grease at all times.

**15) Disconnect tools.** Disconnect tools from the power supply when not in use, before any maintenance operation and when changing accessories such as blades, bits, cutters, etc.

**16) Remove adjusting keys and spanners.** Get into the habit of checking that adjusting keys and spanners have been removed from the machine before turning it on.



**17) Avoid unintentional starting.**

Ensure switch is in "off" position before plugging in the machine.

**18) Use proper extension leads.** When the tool is used outdoors, use only extension leads intended for outdoor use and labelled as such.

**19) Stay alert.** Concentrate on what you are doing, use common sense and do not operate the tool when you are tired.

**20) Check that no part is damaged.**

Before using a tool, make sure that it is in good working order. Check the alignment and condition of moving parts, mounting and any other aspect that may affect its operation. A guard or other part that is damaged should be properly repaired or replaced by an authorised service centre unless otherwise indicated in this instruction manual. Do not use the tool if the switch does not turn on and off.

**21) WARNING.** The use of any accessory or attachment other than one recommended in this instruction manual may present a risk of personal injury.

**22) Have your tool repaired at an authorised service centre.** This electric tool complies with current safety rules. Repairs should only be carried out by an authorised service centre using original spare parts. Failing this, the user could expose themselves to considerable danger.

**HEALTH ADVICE**

**WARNING:** When drilling, sanding, sawing or grinding, dust particles will be produced. In some instances, depending on the materials you are working with, this dust can be particularly harmful to you (e.g. lead from old gloss paint). You are advised to consider the risks associated with the materials you are working with and to reduce the risk of exposure.

**You should:**

- Work in a well-ventilated area.
- Work with approved safety equipment, such as dust masks that are specially designed to filter microscopic particles.

**ADDITIONAL SAFETY INSTRUCTIONS FOR YOUR MITRE SAW**

**WARNING:** Be sure to read and understand all instructions. Failure to follow all instructions listed below may result in electric shock, fire and/or serious personal injury.

**1) Know your power tool.** Read operator's manual carefully. Learn the applications and limitations, as well as the specific potential hazards related to this tool.

**2) Always wear safety glasses or eye shields when using this mitre saw.** Everyday eyeglasses have only impact-resistant lenses; they are not safety glasses.

**3) Always protect your lungs.** Wear a face mask or dust mask if the operation is dusty.

**4) Always protect your hearing.** Wear hearing protection during extended periods of operation.

**5) Inspect the machine's power cord regularly and if damaged have it repaired or replaced.** Always be aware of the cord's location.

**6) Always check for damaged parts.** Before further use of the tool, a guard or other part that is damaged should be carefully checked to determine if it will operate properly and perform its intended function. Check for misalignment or binding of moving parts, breakage of parts, and any other condition that may affect the tool's operation. A guard or other part that is damaged should be properly repaired or replaced at a qualified service centre. Keep guards in place and in working order.

**7) Do not abuse the cord.** Never use the cord to carry the tool or pull the plug from the outlet. Keep cord away from heat, oil, sharp edges or moving parts. Replace damaged cords immediately. Damaged cords increase the risk of electric shock.

**8) Always make sure that your extension cord is in good condition.** When using an extension cord be sure to use one that is heavy enough to carry the current that your tool will draw. An undersized cord will cause a drop in line voltage, resulting in loss of power and overheating.

**9) Do not use the tool while tired or under the influence of drugs, alcohol or any medication.** Following this rule will reduce the risk of electric shock, fire or serious personal injury.

**10) Save these instructions.** Refer to them frequently and use them to instruct others who may use this tool. If someone borrows this tool, make sure they have these instructions also.

**11) When the correct blade to cut the material has been fitted, this saw is recommended for cutting steel and ferrous metals, aluminium and non-ferrous metals, wood, and plastic only.**

**12) Do not use saw blades with High Speed Steel (HSS) or blades that are damaged or deformed.**

**13) Replace the table insert when worn.**

**14) Use only saw blades recommended by the manufacturer and which are the exact bore and diameter required for this machine.**

**15) Connect your mitre saw to a dust collecting device (I.D.Ø32mm) when sawing material likely to cause dust.**

**16) Select saw blades in relation to the material to be cut.** Use only genuine Evolution or Evolution recommended accessories.

**17) Check the maximum depth of cut.**

**18) When sawing long work pieces, always use extra support to provide better support, and use clamps or other clamping devices.** To reduce the risk of injury, return

the slide carriage to the full rear position after each crosscut operation.

**19) The operator is adequately trained in the use adjustment and operation and operation of the machine.**

**20) Provide for adequate room lighting at your workplace or for adequate lighting of the immediate work area.**

**21) When fitted with a laser no exchange with a different type of laser is permissible.** Repairs shall only be carried out by the laser manufacturer or an authorised agent.

**22) Refrain from removing any cut-offs or other parts of the workpiece from the cutting area whilst the machine is running and the saw head is not in the rest position.** Never reach around the saw blade. Turn off tool and wait for saw blade to stop before moving workpiece or changing settings.

**23) Never stand on this tool.** Serious injuries could occur if this tool tips over and you come into contact with the saw blade.

**24) Reduce the risk of unintentional starting.** Make sure switch is in off position before plugging in.

**WARNING:** The operation of any mitre saw can result in foreign objects being thrown into your eyes, which can result in severe eye damage. Before beginning power tool operation, always wear safety goggles or safety glasses with side shield and a full face shield when needed.

**WARNING:** If any parts are missing, do not operate your mitre saw until the missing parts are replaced. Failure to follow this rule could result in serious personal injury.

## CARRYING YOUR MITRE SAW

### Safety Advice

#### 1) Although compact, this saw is heavy.

To reduce the risk of back injury, get competent help whenever you have to lift the saw.

#### 2) To reduce the risk of back injury, hold the tool close to your body when lifting.

Bending your knees so you can lift with your legs, not your back. Lift by using the handhold areas at each side of the bottom of the base.

**3) Never carry the table mitre saw by the power cord or the trigger grip of the handle.** Carrying the tool by the power cord could cause damage to the insulation or the wire connections resulting in electric shock or fire.

**4) Before moving the saw tighten the mitre and bevel lock knobs to guard against sudden movement.**

**5) Lock the cutting head in its lowest position.** Ensure that the cutting head locking pin is completely engaged in its socket.

**WARNING:** Do not use the blade guard as a 'lifting point'. The power cord must be removed from the power supply before attempting to move the machine.

- Lock down the head using the head locking pin.
- Loosen the mitre angle lock knob. Push down the mitre angle lever and rotate the table to either of its maximum settings.
- Lock the table in position using the locking knob.
- Use the two carry handle cut-outs machined into either end of the machine base, to transport the machine.

Place the saw on a secure stationary work surface and check the saw over carefully.

Check particularly the operation of all the machines safety features before commissioning or operating the machine.

## ITEMS SUPPLIED

Description	Quantity
Instruction Manual	1
Hold Down Clamp	1
Push Stick	1
Allen Key (Arbor Lock)	1
Allen Key (Blade Change)	1
Multi-Purpose Blade (Fitted)	1
Rip Fence (Fitted)	1
Auxiliary Lower Blade Guard	1

### Additional Accessories

In addition to the standard accessories supplied with this machine, other accessories are available to improve its performance, these include the following items:

**1) Dust bag** – the design of this machine allows for a dust bag or workshop vacuum extraction device to be fitted to the rear of the machine.

**2) Specialist cutting blades** – use only Evolution Blades with this machine.

Additional accessories can be obtained by contacting your local dealer (or Evolution Power Tools).

**OVERALL VIEW OF RAGE 6 IN MITRE SAW CONFIGURATION**

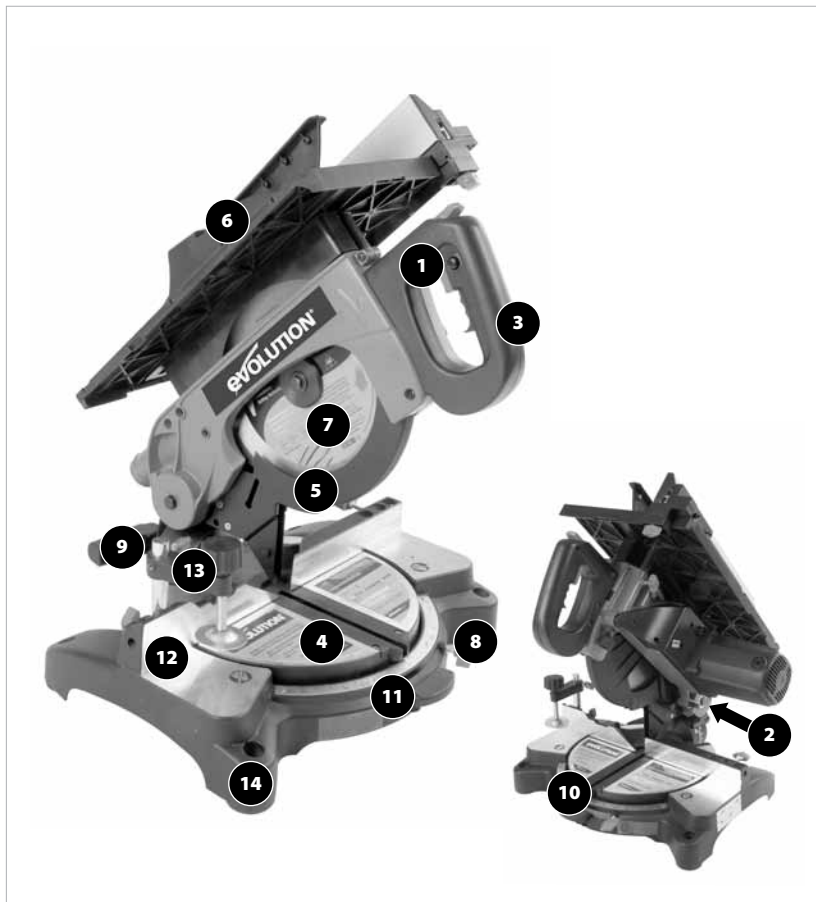

**Know your parts**

- |                             |                                 |
|-----------------------------|---------------------------------|
| 1. On/off trigger switch    | 8. Mitre lock knob              |
| 2. Cutting head locking pin | 9. Bevel angle locking lever    |
| 3. Cutting handle           | 10. Mitre angle scale           |
| 4. Rotary table             | 11. Positive stop locking lever |
| 5. Lower blade guard        | 12. Fence                       |
| 6. Upper blade guard        | 13. Hold down clamp             |
| 7. Blade                    | 14. Mounting hole               |

**OVERALL VIEW OF RAGE 6 IN TABLE SAW CONFIGURATION**

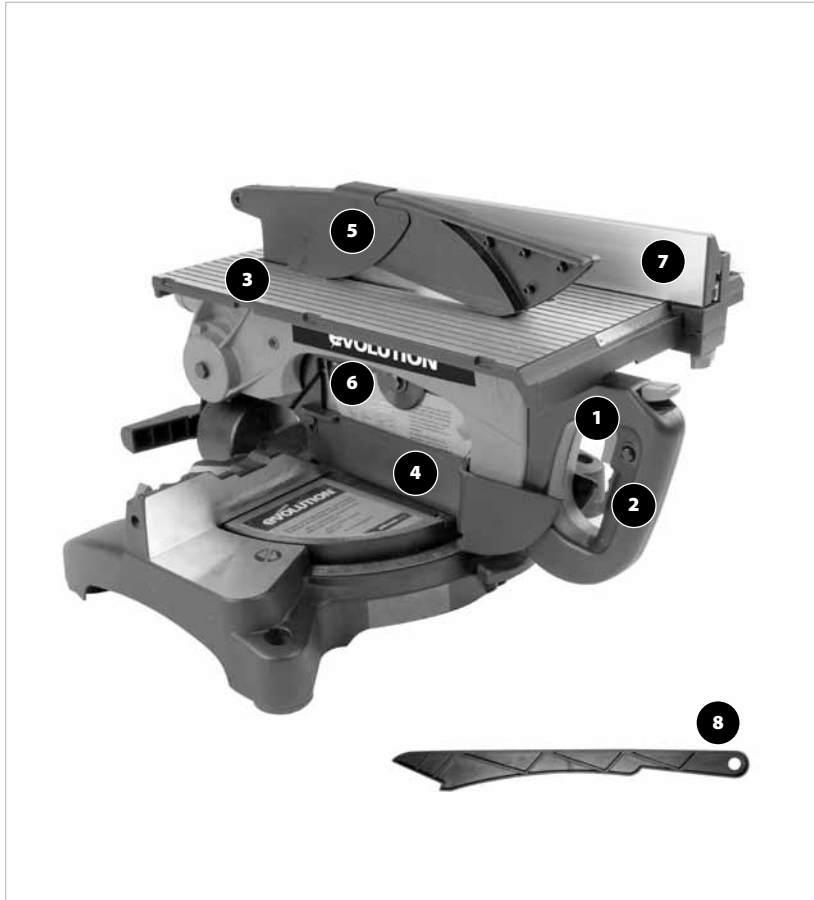

**Know your parts**

- 1. On/off trigger switch
- 2. Cutting handle
- 3. Table top
- 4. Auxilliary lower blade guard
- 5. Upper blade guard
- 6. Blade
- 7. Rip fence
- 8. Push stick

EN

FR

IT

NL

**PARTS DIAGRAM** Parts Diagrams can also be downloaded from [www.evolutionpowertools.com](http://www.evolutionpowertools.com)

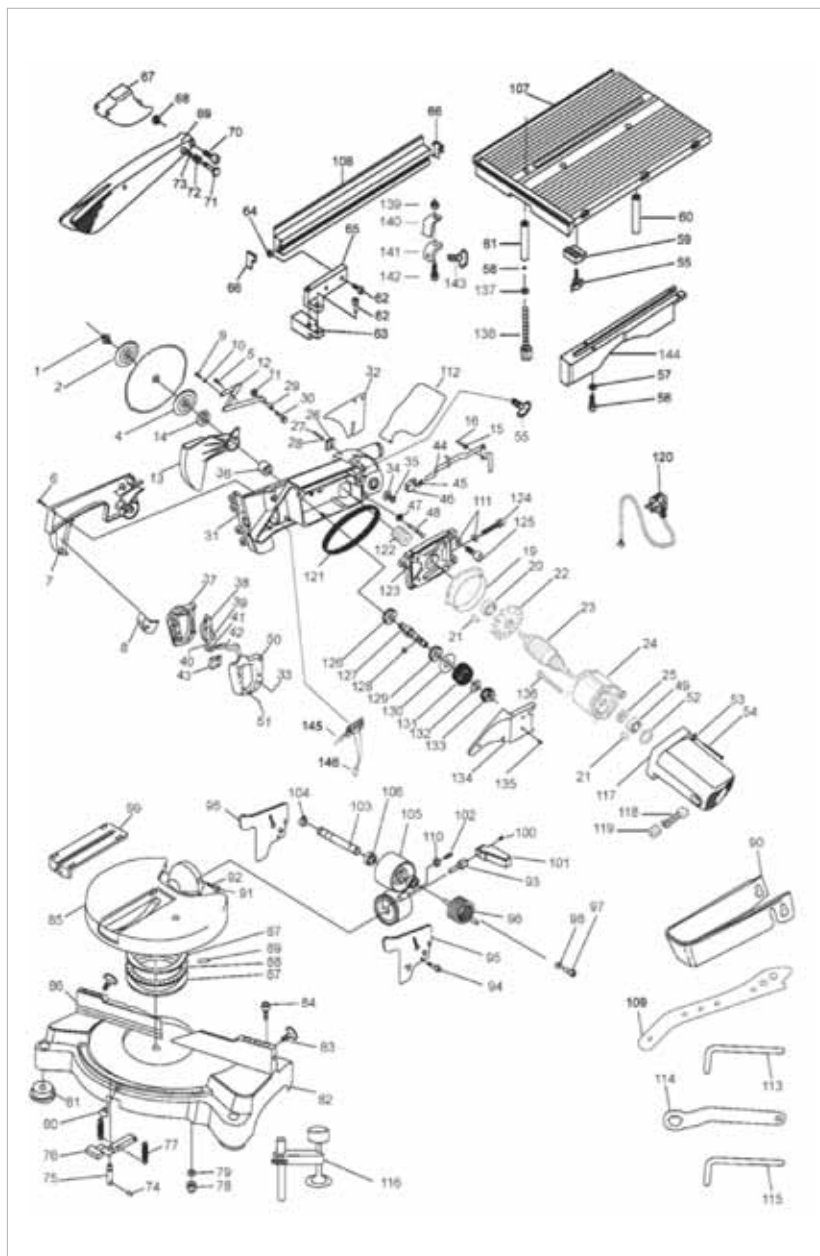

## OPERATION

### GETTING STARTED

**CAUTION! ALWAYS DISCONNECT THE SAW FROM THE POWER SOURCE BEFORE MAKING ANY ADJUSTMENTS.**

Refer to the “Service Parts List Drawing”. Install a blade as detailed in the “Installing or Removing the Blade” section.

#### 1. Mounting the Table Mitre Saw

**WARNING:** To reduce the risk of injury from unexpected saw movement, place the saw in the desired location either on a workbench or other recommended leg set. The base of the saw has four holes to mount the mitre saw. If the saw is to be used in one location, permanently fasten it to the workbench or leg set using appropriate bolts with lock washers and nuts.

- Tighten the mitre and bevel locks.
- Position the saw so other people cannot stand behind it. Thrown debris could injure people in its path.
- Place the saw on a firm, level surface where there is plenty of room for handling and properly supporting the workpiece.
- Support the saw so that the table is level and the saw does not rock.
- Bolt or clamp the saw to its support.

#### 2. Installing or Removing the Blade

**WARNING:** Only use genuine Evolution blades which are designed for this machine. Ensure that the maximum speed of the blade is compatible with the machine. Only perform this operation with the machine disconnected from the mains supply.

**Note:** It is recommended that the operator considers wearing protective gloves when handling the blade during installation or when changing the machines blade.

- Pull out the cutting head locking pin and allow the cutting head to rise to its upper position. **(Fig. 1)**
- Remove the top blade guard with the attached riving knife by loosening the socket headed fixing screw **(Fig. 2)** and withdrawing the riving knife upwards. The riving knife is slotted for easy removal.
- Push in the sprung loaded lower guard operating pawl and slide it upwards along the slot. The lower guard will rotate into the machine exposing the blade. **(Fig. 3)**

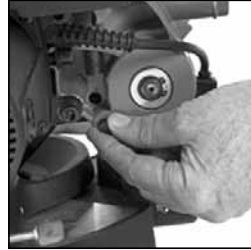

FIG. 1



FIG. 2



FIG. 3

EN

FR

IT

NL

**OPERATION**



**FIG. 4**

- Insert the supplied hex key into the rear labeled arbor access port (**Fig. 4**) Ensure that the hex key engages completely into the arbor socket. Hold the hex key firmly so that the machine arbor cannot rotate.
- Using the supplied Blade Change Allen Key, release the blade arbor screw and remove the outer blade flange and the blade. (**Fig. 4 & 5**)

**Note:** The arbor screw has a LH thread.



**FIG. 5**

- Install the new 255 mm (10") blade by guiding it down through the table slot. Make sure the rotation arrow on the blade matches the clockwise rotation arrow on the upper guard. (**Fig. 6**)

**Note:** The blade teeth should always point downward at the front of the saw. Be careful and patient, the blade is a very precise fit within the machine. Sometimes extra clearance when installing a new blade could be useful. If this is the case raise the table height of the machine as detailed in Operating Instructions – Table Saw Configuration – 2 Adjusting the Table Height.



**FIG. 6**

- Install the outer blade flange and arbor screw. Ensure that the outer blade flange lugs completely engage into the drive flats machined on the machine arbor.
- Whilst preventing the arbor from rotating tighten the arbor screw using moderate force, but do not overtighten.
- Return the lower guard to the 'safe' position by sliding the sprung loaded operating pawl downwards along the slot until it locks in its operating position.
- Alternatively lower and cutting head to its lowest position. The lower guard should return automatically to its operating position with the operating pawl correctly deployed.
- Reinstall the riving knife and top blade guard. Check that the riving knife is close to, but does not foul, the saw blades teeth.
- A gap of 3-5mm between the edge of the riving knife and tips of the blade teeth is ideal.
- Ensure the both Allen Keys are removed and the machines arbor rotates freely.
- Ensure the blade guards are fully functional before using the machine.

**Note:** Spacers and spindle rings should not be used with this machine and/or blade.



## OPERATION

### 3. Debris collection bag (Optional Accessory)

The Debris Collection Bag should be attached at the debris extraction port.

- Slide the frame of the collection bag on to the outlet of the extraction port, ensuring that it is firmly connected.
- To release the bag, slide the frame in the opposite direction.

**Note:** To ensure optimal dust collection, empty the dust bag when it becomes approximately 60% full.

**WARNING:** Before cutting metal materials, the collection bag should be removed and replaced with a blanking plug (not supplied).

Reinstate the dust bag when cutting wood.

### 4. Fitting the Hold Down Clamp (Fig. 7)

Two sockets (one either side) are incorporated into the rear of the machines fence.

- Fit the clamp to the retaining socket that best suits the cutting application, ensuring that it is fully pushed down.
- Tighten the fence thumbscrew to lock the pillar into the socket.
- Put the workpiece to be cut onto the saw rotary table.
- Adjust the clamp using the thumbscrew and hand-wheel so that it securely holds the workpiece to the saw table. Ensure that the clamp does not foul the blade or any other moving machine parts.



**FIG. 7**

**OPERATION**

**OPERATING INSTRUCTIONS**

**MITRE SAW CONFIGURATION**

Disconnect the Table Mitre Saw from the mains supply and inspect your Saw before each use.

**Note:** It is important that the operator is adequately trained in the use, adjustment and operation of the machine and has read this instruction and safety manual before commencing operations.

**WARNING:** To reduce the risk of injury, always unplug the saw before changing or adjusting any of the machines parts. Compare the direction of rotation arrow on the guard to direction arrow on the blade. The blade teeth should always point downward at the front of the saw. Check the tightness of the arbor screw.

In mitre saw configuration the lower auxiliary guard should be removed from the machine and safely stored for future use.

The upper blade guard must be secured to the riving knife using the sprung loaded locating pin.

The table should be adjusted so that it is in its upper most position. See section 2 Table Saw Configuration for adjusting procedure. In this position the upper blade guard will be effectively locked down over the crown of the blade.



**FIG. 8**

**1. Releasing the saw head**

- Gently press down on the cutting handle.
- Pull out the head stop latching knob and allow the head to rise to its upper position. **(Fig. 8)**

**Note:** The cutting head will automatically lock in the upper position.

We recommend that when the machine is not in use the cutting head is locked in its down position, and the latching knob fully engaged in its socket.

**2. Preparing to make a cut**

- Avoid awkward operations and hand positions where a sudden slip could cause fingers or hands to move into the blade.
- Cut only one workpiece at a time.
- Clear everything except the workpiece and related support devices away from the blade before turning the mitre saw on.
- Secure workpiece using clamps to hold the workpiece securely.

## OPERATION

### 3. Body and Hand Position

- Never place hands near the cutting area and keep hands away from the path of the blade.
- Hold the workpiece firmly to the fence to prevent movement. Use a clamp if necessary but check that it is positioned so that it does not foul the blade.
- Before making a cut. Make a dry run with the power off so you can see the path of the blade.
- Keep hands in position until the ON/OFF trigger has been released and the blade has completely stopped.

### 4. On/Off Switch Operation

The On/Off switch is located in the cutting handle (**Fig. 9**) and incorporates several safety features to guard against accidental actuation.

To switch 'On'

- Grasp the saw handle.
- Slide the trigger switch safety locking slide downwards.
- Press the trigger switch. The machine will start. To release the lower safety guard and cutting head, press the head release thumb button on the top of the saw handle. (**Fig. 10**)
- Gently lower the cutting head through the workpiece to make a cut.

To switch 'Off'

- Allow the cutting head to rise to its upper position.
- Release the trigger switch, thumb button and safety locking slide.
- Wait for the saw blade to completely stop before removing your hand from the cutting handle.
- The safety locking slide and head release button will automatically deploy to 'safety mode'.

### 5. Chop Cutting

The saw handle is gently pushed down to cut through a workpiece.

- Place the workpiece on the table and against the fence in the desired position. Secure with clamps if necessary.
- Grasp the saw handle.
- Turn on the saw using the trigger switch and allow the blade to reach full operating speed.
- Press the cutting head release button to release the saw head.
- Gently push the saw head down and cut through the workpiece.
- After the cut is completed, turn off the saw by releasing the trigger switch, and allow the blade to come to a complete halt before removing your hands or the workpiece from the machine.



FIG. 9



FIG. 10

**OPERATION**



**FIG. 11**



**FIG. 12**

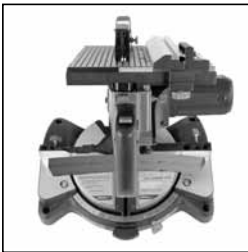

**FIG. 13**

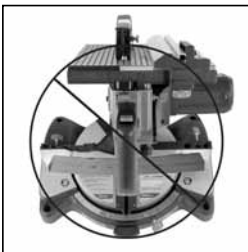

**FIG. 14**

**6. Mitre Cutting**

Any angle from 50° left to 50° right is available, and a protractor scale can be found on the front of the machine table.

Positive stops are provided at 0°, and 15°, 22.5°, 30° and 45° to the RH and LH side.

- Loosen the mitre angle locking screw. This is situated on the RH side of the machine table just above the 22.5° index mark.
- Push down the positive stop locking lever and turn the table to the desired angle as indicated on the mitre protractor scale by using the cutting handle. Lock in the required position by tightening the mitre angle locking screw.

**(Fig. 11)** A small index pointer can be found under the table insert to aid accurate setting.

- If utilizing the positive stop facility it is still good practice to lock the table into position using the mitre locking screw
- Start the saw and allow it to reach full operating speed before making the cut.

**7. Bevel Cutting**

The cutting head can be set at any angle up to a 45° to the LH side only.

The bevel angle locking lever is found at the rear of the machine and a protractor guide and pointer is incorporated into the casting to the front of the locking lever to aid setting.

**(Fig. 12)**

- Loosen the bevel lock lever.
- Tilt the saw head to the desired angle. Use the protractor guide provided to the front of the lever to aid setting.
- Ensure the locking lever is tightened securely when the required angle has been achieved.
- Stand to the left hand side of the handle to make the cut.

**8. Compound Cutting**

A compound cut is a combination of a mitre cut and a bevel cut.

- Select the required mitre angle as previously described.
- Select the required bevel angle as previously described.
- Ensure the tightness of all adjustment/locking screws before making a cut.

**9. Cutting Bowed Material**

Before cutting any workpiece, check to see if it is bowed. If it is bowed the workpiece must be positioned and cut as shown.

**(Fig. 13 & Fig. 14)**

Do not position the workpiece incorrectly or cut the workpiece without the support of the fence.

## OPERATION

### 10. Clearing Jammed Material

- Turn mitre saw "OFF" by releasing the trigger switch.
- Allow the blade to come to a complete halt and the cutting to rise to its upper position if possible.
- Unplug the mitre saw from the mains supply.
- Carefully remove any jammed material from the unit.

### 11. Supporting Long Workpieces

The free end of a long workpiece should be supported at the same height as the machine's rotary table. The operator should consider using a remote workpiece support stand or enlisting competent trained help if thought necessary.

## TABLE SAW CONFIGURATION

**WARNING:** To operate as a table saw certain adjustments/checks must be carried out to ensure that the machine is configured correctly. Optimally the table saw is best suited to the Rip Cutting of sheet material.

- The cutting head must be in the locked down position with the locking pin completely engaged in its socket.
- The rotary table should be set at 0° and locked in position with the mitre locking screw.
- The cutting head should be locked at 0° bevel with the bevel locking lever securely tightened.
- The auxiliary lower blade guard must be fitted.

**Note:** Ensure that these checks/adjustments are carried out with the machine disconnected from the mains supply.

### 1. Fitting the Auxiliary Lower Blade Guard

- Ensure that the cutting head is in its upper position.
- Position the lower auxiliary guard over the rotary table insert and slide it to the rear. Narrow end of the guard to the rear, open wide end to the front.
- Ensure that the RH and LH sides of the guard engage with their respective locating pins on the lower rear fixed blade guard, and that the cut out slot on the RH side of the auxiliary guard straddles the machine fence. (**Fig. 15**)
- When satisfied that the lower auxiliary guard is correctly positioned, lower the cutting head to its lowest position and securely lock in place with the locking pin.
- Check the integrity of the installation, and that the machine handle has trapped the auxiliary guard in place. (**Fig. 16**)

**WARNING:** The Auxiliary Blade Guard must be fitted when this machine is used as a Table Saw. Do not operate this machine if the Auxiliary Blade Guard is damaged or missing.

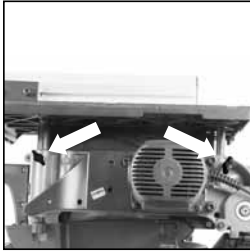

**FIG. 15**



**FIG. 16**

**OPERATION**



**FIG. 17**



**FIG. 18**

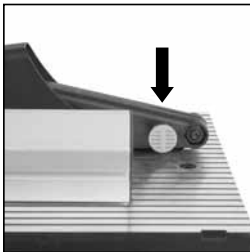

**FIG. 19**

**2. Adjusting the Table Height**

The height of the machine table top above the machine motor can be adjusted. This enables your Evolution Table/Mitre Saw to mimic the rise and fall facility found on many conventional table saws. The cutting depth of the blade can thereby be adjusted from 0mm to 50mm.

**WARNING:** Only adjust the height of the table with the machine disconnected from the mains power supply.

To adjust:

- Loosen the two table pillar wing nuts, one to the front, and one to the rear underneath the machine table. **(Fig. 17)**
- Turn the height adjustment screw **(Fig. 18)** clockwise or counter-clockwise until the saw blade protrudes through the table by the required amount.
- Tighten the two table pillar wing nuts securely.

**Note:** The upper blade guard can be rotated backwards to allow access to the table top so that a machinist ruler can be used to measure the height of the blade above the table.

To gain access –

- Pull out the sprung loaded locating pin at the rear of the upper guard **(Fig. 19)**
- Rotate the guard backwards.

**WARNING:** Always return the guard to its operational position with the locating pin fully engaged in its hole in the riving knife when measuring has been completed.

Never use the machine without the upper guard in its operational position. Check the operation of the upper guard after every adjustment.

Return the table to its original (lowest) position when cutting is completed.

## OPERATION

### 3. The Rip Fence

An adjustable Rip Fence is positioned to the RH side of the blade. The Rip Fence can be locked into the desired position by tightening a wing nut found underneath the Rip Fence Carrier. **(Fig. 20)**

The Rip Fence rail is an integral part of the machine table and contains a measurement scale to aid setting.

Do not position the Rip Fence to the LH side of the blade. Forwards and backwards adjustment of the rip fence is possible. Loosen the two socket headed screws with a suitable Allen key and slide the aluminium extrusion to the desired position. Tighten the socket screws firmly. **(Fig. 21)**

**Note:** We recommend that normally the rip fence be adjusted so that the rear of the guide is level with the rear of the blade where it emerges from the table.

The aluminium fence guide can be attached to the fence carrier in a 'Hi' and a 'Lo' position. The 'normal' and factory supplied position is with the fence set to the 'Hi' setting. The 'Lo' setting can be useful when cutting very thin sheet material.

To re-position the Rip Fence to the 'Lo' setting:

- Loosen the two socket headed screws.
- Slide the aluminium extrusion from the carrier.
- Re-attach the aluminium extrusion to the carrier in the 'Lo' position.
- Tighten the two socket headed screws with the fence in the required position. **(Fig. 22)**

## BASIC TABLE SAW OPERATIONS

**WARNING:** Never attempt freehand cuts on this machine. Always use the Rip Fence Guide to minimise the possibility of the blade binding and kickback. We recommend that the saw blade protrudes through the material to be cut by approximately 3mm.

Adjust the cutting height of the blade by adjusting the height of the machine table as previously described. This machine is not suitable for cutting rebates or stopped grooves. A workshop dust extraction device can be connected to the extraction port found at the rear of the machine if required.

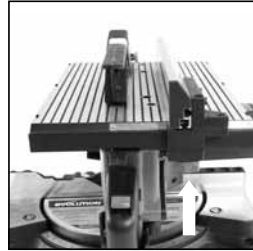

**FIG. 20**

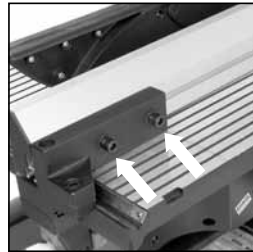

**FIG. 21**

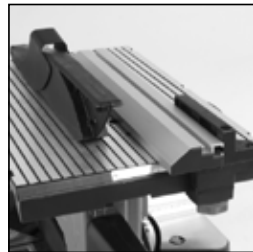

**FIG. 22**

EN

FR

IT

NL

**OPERATION**



**FIG. 23**

**1. On/Off Switch Operation**

To start the machine:

- Slide the trigger switch safety locking slide downwards.
- Press the trigger switch. The machine will start.
- Push in the trigger locking button (**Fig. 23**) for continuous motor operation.

When cutting is completed, gently press the trigger switch to release the trigger locking button. The machine will stop and the safety locking slide will automatically deploy.

**2. Rip cutting**

Rip cutting is cutting along the length of a piece of material rather than across it.

Rip cutting should always be done with the Rip Fence set to the desired width and on the RH side of the machines table.

**Note:** Check that the rip fence is locked in position and is parallel to the saw blade. Check that the riving knife is properly aligned with the saw blade.

When ripping small section material a push stick should be used to feed/guide the final 300mm of the material past the blade. A push stick should always be used when making cuts of less than 300mm.

When ripping long boards or large panels always use a remote work support or enlist competent trained help.

Feed the workpiece through the saw keeping it indexed against the rip fence. Use smooth, steady pressure and employ a push stick if necessary. Hands should never be in line with the blade.



## MAINTENANCE

**WARNING:** Ensure that the machine is disconnected from the mains supply before any maintenance tasks or adjustments are attempted.

### Cleaning

After each use the machine should be cleaned. Remove all sawdust etc from the visible parts of the machine with a vacuum cleaner. A vacuum cleaner can also be connected to the machine dust extraction port at the rear of the machine. This should remove debris from the inside of the machine. Never use solvents to clean plastic parts, as solvents can damage them. Clean only with a soft damp cloth.

### Riving Knife

The riving knife is a very important component and comes factory fitted and correctly aligned and adjusted. The riving knife prevents the work from binding as it passes through the blade. Inspect the riving knife at regular intervals and replace it if it is worn or damaged.

**Note:** Use only a genuine Evolution Riving Knife, as this is a dedicated component for this machine. Non genuine parts could be dangerous. If in any doubt, please contact the Helpline.

### Push Stick

A plastic push stick is provided with the machine. When not in use store the push stick on the machine.

**Note:** If the push stick becomes damaged it should be replaced. If the operator makes their own push stick, we recommend that it follows the same pattern as that supplied.

Replacement push sticks are available from Evolution Power Tools.

**MAINTENANCE**



**FIG. 24**

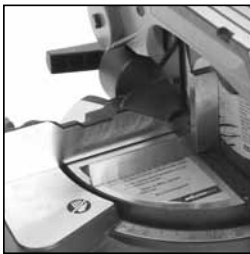

**FIG. 25**



**FIG. 26**



**FIG. 27**

**PRECISION SETTING OF ANGLES**

**WARNING:** Before making any adjustments, or carrying out maintenance to the saw, make sure that it is disconnected from the mains supply.

When all adjustments, settings or maintenance have been completed, make sure that all keys or wrenches have been removed, and that all screws, bolts and other fittings are securely tightened.

While the machine has been factory set, it is advisable that the 0° setting of the rotary table and the 90° perpendicular setting of the tilt head be checked, as these positions may have moved in transit.

To confirm the 0° rotary table setting:

- Set the rotary table at 0° and tighten the rotary table lock handle.
- Use an engineers square (not supplied) to check that the angle between the machines fence guide and the blade is 90°. **(Fig. 24)**
- If the angle requires adjustment, loosen the four fence guide clamp screws and align the fence guide against the engineers square. Retighten the clamp screws.

Similarly check that the angle of the saw blade to the face of the table is 90°. **(Fig. 25)**

To adjust:

- Loosen the locknut
- Using a suitable allen key/screwdriver turn the 90° adjustment screw clockwise or counter clockwise until correct alignment has been achieved. **(Fig. 26)**
- Retighten the locknut.

The 45° bevel setting can also be adjusted.

- Set the cutting head to 45° and check the angle between the blade and the machine table with a 45° set square (not provided).
- To adjust, loosen the 45° adjusting screw locknut and using a suitable allen key/screwdriver turn the adjusting screw clockwise or anti- clockwise until the correct alignment is achieved. **(Fig. 27)**
- Retighten the locknut.

## **MAINTENANCE**

### **PLUG REPLACEMENT**

The fuse in the main plug of your power tool should always be replaced with one of identical rating.

Check the voltage given on your power tool matches the supply voltage.

The power tool is supplied with a fitted plug, however if you should need to fit a new plug follows the instruction below.

### **IMPORTANT**

The wire in the mains lead are coloured in accordance with the following code:

Blue - Neutral

Brown - Live

Green/Yellow - Earth

The wire that is coloured blue must be connected to the terminal that is marked with the letter N. The wire that is coloured brown must be connected to the terminal that is marked with the letter L. The wire that is coloured green/yellow must be connected to the terminal that is marked with the letter E.

A 13AMP (BS1363 or BS1363/A) plug must be used and a 5 AMP fuse must be fitted.

## **ENVIRONMENTAL PROTECTION**

Waste electrical products should not be disposed of with household waste. Please recycle where facilities exist. Check with your Local Authority or retailer for recycling advice.



**EC DECLARATION OF CONFORMITY**

In accordance with EN ISO 17050-1:2004



**The manufacturer of the product covered by this Declaration is:**

Evolution Power Tools, Venture One, Longacre Close, Holbrook Industrial Estate, Sheffield, S20 3FR.

The manufacturer hereby declares that the machine as detailed in this declaration fulfils all the relevant provisions of the Machinery Directive and other appropriate directives as detailed below. The manufacture further declares that the machine as detailed in this declaration, where applicable, fulfils the relevant provisions of the Essential Health and Safety requirements.

**The Directives covered by this Declaration are as detailed below:**

<b>2006/42/EC.</b>	Machinery Directive.
<b>2004/108/EC.</b>	Electromagnetic Compatibility Directive.
<b>93/68/EC.</b>	The CE Marking Directive.
<b>2011/65/EU.</b>	The Restriction of the Use of certain Hazardous Substances in Electrical Equipment (RoHS) Directive.
<b>2002/96/EC as amended by 2003/108/EC .</b>	The Waste Electrical and Electronic Equipment (WEEE) Directive.

**And is in conformity with the applicable requirements of the following documents:**

<b>EN 61000-6-3:2007 • EN 55014-1:2006 • EN 55014-2+A2:2008 EN 60745-1:2009 • EN 60745-2-11+A12:2009</b>
--

**Product Details**

Description: RAGE6 255mm (10") MULTIPURPOSE MITRE/TABLE SAW  
 Evolution Model No: RAGE62551 / RAGE62552 / RAGE62552EU  
 Brand Name: EVOLUTION  
 Voltage: 110V / 230V  
 Input: 50Hz

The technical documentation required to demonstrate that the product meets the requirements of directive has been compiled and is available for inspection by the relevant enforcement authorities, and verifies that our technical file contains the documents listed above and that they are the correct standards for the product as detailed above.

**Name and address of technical documentation holder.**

Signed:  Print: Steven Bulloss: Operations Director.

Signed:  Print: Lettie Lui: Product Manager.

Date: 07/03/2011

**NOTES**

EN

FR

IT

NL

# evOLUTION®

www.evolutionpowertools.com

## UK

Evolution Power Tools Ltd  
Venture One  
Longacre Close  
Holbrook Industrial Estate  
Sheffield  
S20 3FR

+44 (0)114 251 1022

## US

Evolution Power Tools LLC  
8363 Research Drive  
Davenport  
Iowa  
52806

866-EVO-TOOL

## JP

エボリューション  
パワーツール株式会社  
〒544-0031  
大阪府大阪市生野区  
鶴橋5丁目21-19

0120-051-415

## EU

Evolution Power Tools Ltd  
61 Avenue Lafontaine  
33560  
Carbon-Blanc  
Bordeaux

+ 33 (0)5 57 30 61 89

---

## Discover Evolution Power Tools

Visit: [www.evolutionpowertools.com](http://www.evolutionpowertools.com) or download  
the QR Reader App on your smart phone and scan  
the QR code (Right).

