

Erbauer®



ERB575DRH

2Year
Guarantee

1250W 6kg HAMMER DRILL

ERB575DRH

Original Instructions
(Version 1.0)

 **CAUTION**

This is a very powerful Drill.

When using this drill it is essential that the following rules for use are followed!

1. When drilling it is common that the core / drill bit jams in the material being drilled. This will result in the drill trying to rotate around the drill bit and potentially come out of your grip. This SDS Drill has a safety clutch mechanism. This safety clutch mechanism will be activated and stop the drive to the drill bit **BUT** only if you resist the initial forces caused by the jamming by securely holding the drill with both hands. As this is a very powerful drill these forces are significant.
2. **ALWAYS** ensure that the front handle is firmly affixed and secure.
3. The Front and rear handle must be firmly held to resist any movement of the drill when the core drill or drill bit becomes jammed.
4. **ALWAYS** use this drill when standing on a firm and secure platform or the ground. **(DO NOT USE ON LADDERS OR STEPS)**
5. **NEVER** Start the Drill with the core or drill jammed in position.
6. **DO NOT** stretch to hold the drill. Do not drill above shoulder height or below Knee height, as the drill cannot be securely held.
7. Never drill holes that are above the declared maximum size in the manual.

Erbauer®

Congratulations on your purchase of a quality power tool from Erbauer (UK) Ltd. This product should give you reliable service but for your peace of mind this **Erbauer power tool does carry a 2 year guarantee, the terms of which are detailed below.**

If this product develops a fault within the guarantee period contact your retailer.

Please retain this handbook in case you need to refer to safety, care or guarantee information in the future.

GUARANTEE

This **Erbauer** product carries a 2 year guarantee. If your product develops a fault within this period, you should in the first instance contact the retailer where the item was purchased.

This guarantee specifically excludes losses caused due to:

- Fair wear and tear
- Misuse or abuse
- Lack of routine maintenance
- Failure of consumable items (such as batteries)
- Accidental damage
- Cosmetic damage
- Failure to follow manufacturer's guidelines
- Loss of use of the goods

This guarantee does not affect your statutory rights. This guarantee is only valid in the UK.

For further technical advice, spare parts or repair service (outside of guarantee) please contact the customer helpline number on 0345 607 6380.

GENERAL POWER TOOL SAFETY WARNINGS

 **Warning: Read all safety warnings and all instructions.** Failure to follow the warnings and instructions may result in electric shock, fire and/or serious injury.

Save all warnings and instructions for future reference.

The term “power tool” in the warnings refers to your electric (corded) power tool or battery-operated (cordless) power tool.

1. Work area safety

a. Keep work area clean and well lit. Cluttered or dark areas invite accidents.

b. Do not operate power tools in explosive atmospheres, such as in the presence of flammable liquids, gases or dust. Power tools create sparks which may ignite the dust or fumes.

c. Keep children and bystanders away while operating a power tool. Distractions can cause you to lose control.

2. Electrical safety

a. Power tool plugs must match the outlet. Never modify the plug in any way. Do not use any adapter plugs with earthed (grounded) power tools. Unmodified plugs and matching outlets will reduce risk of electric shock.

b. Avoid body contact with earthed or grounded surfaces, such as pipes, radiators, ranges and refrigerators. There is an increased risk of electric shock if your body is earthed or grounded.

c. Do not expose power tools to rain or wet conditions. Water entering a power tool will increase the risk of electric shock.

d. Do not abuse the cord. Never use the cord for carrying, pulling or unplugging the power tool. Keep cord away from heat, oil, sharp edges or moving parts. Damaged or entangled cords increase the risk of electric shock.

e. When operating a power tool outdoors, use an extension cord suitable for outdoor use. Use of a cord suitable for outdoor use reduces the risk of electric shock.

f. If operating a power tool in a damp location is unavoidable, use a residual current device (RCD) protected supply. Use of an RCD reduces the risk of electric shock.

3. Personal safety

a. Stay alert, watch what you are doing and use common sense when operating a power tool. Do not use a power tool while you are tired or under the influence of drugs, alcohol or medication. A moment of inattention while operating power tools may result in serious personal injury.

b. Use personal protective equipment. Always wear eye protection. Protective equipment such as dust mask, non-skid safety shoes, hard hat, or hearing protection used for appropriate conditions will reduce personal injuries.

c. Prevent unintentional starting. Ensure the switch is in the off-position before connecting to power source and/or battery pack, picking up or carrying the tool. Carrying power tools with your finger on the switch or energising power tools that have the switch on invites accidents.

d. Remove any adjusting key or wrench before turning the power tool on.

A wrench or a key left attached to a rotating part of the power tool may result in personal injury.

e. Do not overreach. Keep proper footing and balance at all times. This enables better control of the power tool in unexpected situations.

f. Dress properly. Do not wear loose clothing or jewellery. Keep your hair, clothing and gloves away from moving parts. Loose clothes, jewellery or long hair can be caught in moving parts.

g. If devices are provided for the connection of dust extraction and collection facilities, ensure these are connected and properly used. Use of dust collection can reduce dust-related hazards.

4. Power tool use and care

a. Do not force the power tool. Use the correct power tool for your application. The correct power tool will do the job better and safer at the rate for which it was designed.

b. Do not use the power tool if the switch does not turn it on and off. Any power tool that cannot be controlled with the switch is dangerous and must be repaired.

c. Disconnect the plug from the power source and/or the battery pack from the power tool before making any adjustments, changing accessories, or storing power tools. Such preventive safety measures reduce the risk of starting the power tool accidentally.

d. Store idle power tools out of the reach of children and do not allow persons unfamiliar with the power tool or these instructions to operate the power tool. Power tools are dangerous in the hands of untrained users.

e. Maintain power tools. Check for misalignment or binding of moving parts, breakage of parts and any other condition that may affect the power tool's operation. If damaged, have the power tool repaired before use. Many accidents are caused by poorly maintained power tools.

f. Keep cutting tools sharp and clean. Properly maintained cutting tools with sharp cutting edges are less likely to bind and are easier to control.

g. Use the power tool, accessories and tool bits etc. in accordance with these instructions, taking into account the working conditions and the work to be performed. Use of the power tool for operations different from those intended could result in a hazardous situation.

5. Service

a. Have your power tool serviced by a qualified repair person using only identical replacement parts. This will ensure that the safety of the power tool is maintained.

HAMMER SAFETY WARNINGS

- 1. Wear ear protectors.** Exposure to noise can cause hearing loss.
- 2. Use auxiliary handle, if supplied with the tool.** Loss of control can cause personal injury.
- 3. Hold power tool by insulated gripping surfaces, when performing an operation where the cutting accessory may contact hidden wiring or its own cord.** Cutting accessory contacting a "live" wire may make exposed metal parts of the power tool "live" and could give the operator an electric shock.
- 4. Always wear a dust mask.**
- 5. Connect the mains plug only when the tool is switched off. After using, pull the mains plug.**
- 6. Always direct the cable to the rear away from the machine.**
- 7. Persons under 16 years of age are not permitted to operate this machine.**

8. Keep the tool and accessories out of the reach of children.
9. Remove the plug from the socket before carrying out any adjustment, servicing or maintenance.
10. When an extension cable is required you must ensure it has the correct ampere rating for your power tool and that it is in a safe electrical condition. And please fully unwind cable drum extensions to avoid potential over heating.
11. Ensure your mains supply voltage is the same as your tool rating plate voltage.
12. Your tool is double insulated for additional protection against a possible electrical insulation failure within the tool.
13. Always check walls and ceilings to avoid hidden power cables and pipes.
14. After long working periods, external metal parts and accessories could be hot.
15. Wear eye protection when operating this tool.
16. Your hand must hold on the handle when you are working. Always use the auxiliary handles supplied with the tool. Loss of control can cause personal injury

ADDITIONAL SAFETY WARNING FOR CONSTRUCTION DUST

The updated Control of Substances Hazardous to Health Regulations 1st October 2012 now also targets to reduce the risks associated with silica, wood and gypsum dusts. Construction workers are one of the at-risk groups within this because of the dust that they breathe: silica dust is not just a nuisance; it is a real risk to your lungs!

Silica is a natural mineral present in large amounts in things like sand, sandstone and granite. It is also commonly found in many construction materials such as concrete and mortar. The silica is broken into very fine dust (also known as Respirable Crystalline Silica or RCS) during many common tasks such as cutting, drilling and grinding

Breathing in very fine particles of crystalline silica can lead to the development of:

Lung cancer

Silicosis

Chronic Obstructive Pulmonary Disorder (Chronic obstructive pulmonary disease (COPD))

And breathing in fine particles of wood dust can lead to the development of Asthma

The risk of lung disease is linked to people who regularly breathe construction dust over a period of time, not on the odd occasion.

To protect the lung, the COSHH Regulations sets a limit on the amount of these dusts that you can breathe (called a Workplace Exposure Limit or WEL) when averaged over a normal working day. These limits are not a large amount of dust: when compared to a penny it is tiny – like a small pinch of salt:

This limit is the legal maximum; the most you can breathe after the right controls have been used.

How to reduce the amount of dust?

1. Reduce the amount of cutting by using the best sizes of building products.
2. Use a less powerful tool e.g. a block cutter instead of angle grinder.

1250W 6kg HAMMER DRILL

ERB575DRH

- Using a different method of work altogether – e.g. using a nail gun to direct fasten cable trays instead of drilling holes first.

Please always work with approved safety equipment, such as those dust masks that specially designed to filter out microscopic particles and use the dust extraction facility at all time.

For more information please see the HSE website:

<http://www.hse.gov.uk/construction> or <http://www.hse.gov.uk/pubns/cis69.pdf>

Warning: Some dust particles created by power sanding, sawing, grinding, drill and other construction jobs contain chemicals known to cause cancer, birth defects or other reproductive harm. Some examples of these chemicals are:

- Lead from lead-based paints.
- Crystalline silica from bricks and cement and other masonry products.
- Arsenic and chromium from chemically treated timber.

Your risk from these exposures varies, depending upon how often you do this type of work. To reduce your exposure to these chemicals:

- Work in a well-ventilated area.
- Work with approved safety equipment, such as those dust masks that are specially designed to filter microscopic particles.

VIBRATION

The European Physical Agents (Vibration) Directive has been brought in to help reduce hand arm vibration syndrome injuries to power tool users. The directive requires power tool manufacturers and suppliers to provide indicative vibration test results to enable users to make informed decisions as to the period of time a power tool can be used safely on a daily basis and the choice of tool.

Further Advice can be found at www.hse.gov.uk

Vibration total values (triax vector sum) determined according to EN 60745:	
Mode description	Vibration emission value $a_{h,HD} = 17.4\text{m/s}^2$ (main handle)
	$a_{h,HD} = 12.6\text{m/s}^2$ (auxiliary handle)
	Uncertainty $K = 1.5\text{m/s}^2$
Chiseling	Vibration emission value $a_{h,Cheq} = 14.3\text{m/s}^2$ (main handle)
	$a_{h,Cheq} = 8.6\text{m/s}^2$ (auxiliary handle)
	Uncertainty $K = 1.5\text{m/s}^2$

The declared vibration emission value should be used as a minimum level and should be used with the current guidance on vibration.

Calculating the actual period of the actual period off use can be difficult and the HSE website has further information.

The declared vibration emission been measured in accordance with a standardised test stated above and may be used to compare one tool with another tool.

The declared vibration emission value may also be used in a preliminary assessment of exposure.

 **Warning:** The vibration emission value during actual use of the power tool can differ from the declared value depending on the ways in which the tool is used dependant on the following examples and other variations on how the tool is used:

How the tool is used and the materials being cut or drilled.

The tool being in good condition and well maintained

The use the correct accessory for the tool and ensuring it is sharp and in good condition.

The tightness of the grip on the handles.

And the tool is being used as intended by its design and these instructions.

While working with this power tool, hand/arm vibrations occur. Adopt the correct working practices in order to reduce the exposure to vibration.

This tool may cause hand-arm vibration syndrome if its use is not adequately managed.

 **Warning:** Identify safety measures to protect the operator that are based on an estimation of exposure in the actual conditions of use (taking account of all parts of the operating cycle such as the times when the tool is switched off and when it is running idle in addition to the trigger time). Note The use of other tools will reduce the users' total working period on this tool.

Helping to minimise your vibration exposure risk.

ALWAYS use sharp chisels, drills and blades

Maintain this tool in accordance with these instructions and keep well lubricated (where appropriate)

Avoid using tools in temperatures of 10°C or less

Plan your work schedule to spread any high vibration tool use across a number of days.

Health Surveillance

All employees should be part of an employer's health surveillance scheme to help identify any vibration related diseases at an early stage, prevent disease progression and help employees stay in work.

Double insulation

The tool is double insulated. This means that all the external metal parts are electrically insulated from the mains power supply. This is done by placing insulation barriers between the electrical and mechanical components making it unnecessary for the tool to be earthed.

Important note

Be sure the supply is the same as the voltage given on the rating plate. The tool is fitted with a two-core cable and plug.

Remove the mains plug from socket before carrying out, any adjustment or servicing.

Torque limiter

There is a clutch in your rotary hammer drill.

The torque limiter will actuate when a certain torque level is reached. The motor will disengage from the output shaft. When this happens, the bit will stop turning.

As soon as the torque limiter actuates, switch off the tool immediately and remove the drill bit from the hole completely. This will help prevent premature wear of the tool.

SYMBOLS



To reduce the risk of injury, user must read instruction manual



Warning



Double insulation



Wear ear protection



Wear eye protection



Wear dust mask



Wear safety gloves



Waste electrical products should not be disposed of with household waste.
Please recycle where facilities exist. Check with your Local Authority
or retailer for recycling advice.

yyWxx Manufacturing date code; Year of manufacturing (20yy) and week of manufacturing (Wxx);

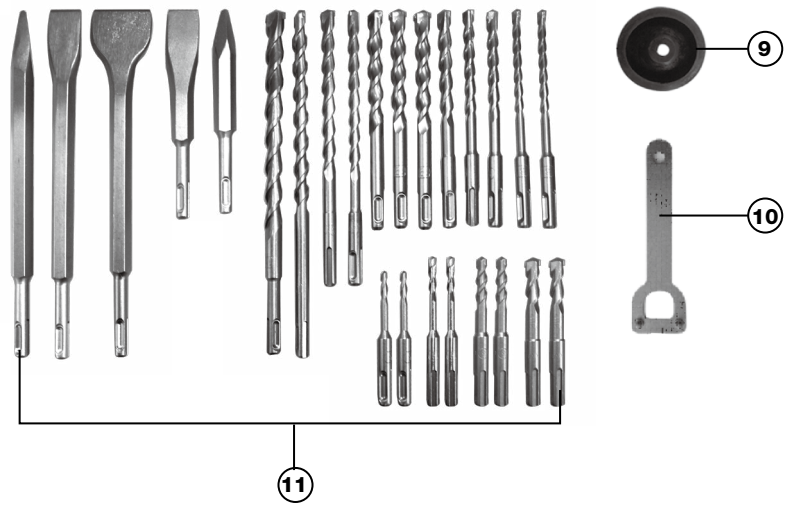
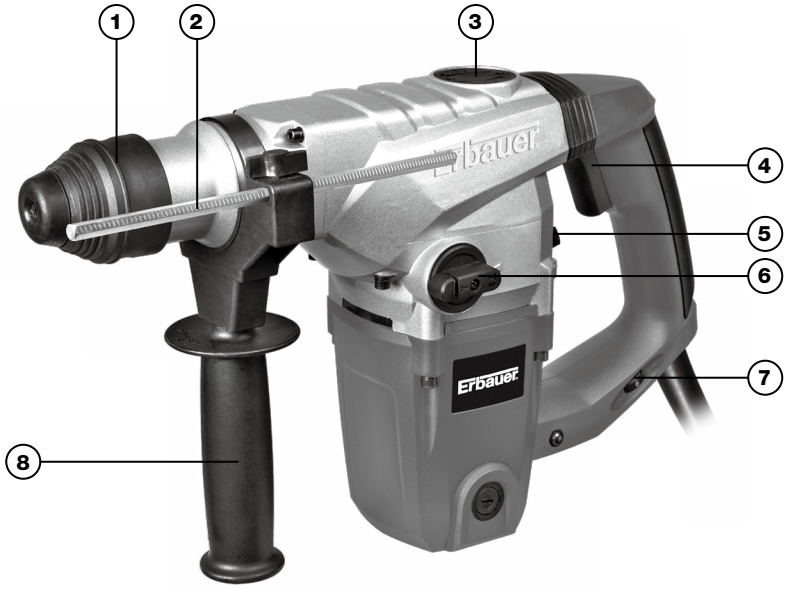

1250W 6kg HAMMER DRILL

ERB575DRH

-
1. LOCKING SLEEVE

 2. DEPTH GAUGE

 3. GREASE BOX COVER

 4. ON / OFF SWITCH

 5. HAMMER OR DRILLING ACTION SELECTOR SWITCH 1

 6. HAMMER OR CHISEL ACTION SELECTOR SWITCH 2

 7. VARIABLE SPEED CONTROL

 8. AUXILIARY HANDLE

 9. DUST COVER

 10. SPANNER

 11. ACCESSORY KITS*
-

* The details were listed in accessories part.

TECHNICAL DATA

Voltage	220-240V~ 50Hz
Power input	1250W
No load speed	0-750/min
Impact rate	0-3700bpm
Impact energy	5.0J
Chuck type	SDS-plus
Max drilling capacity	
	Steel 13mm
	Masonry 32mm
	Wood 40mm
Protection class	□/II
Machine weight	5.6kg

NOISE INFORMATION

A weighted sound pressure:	L_{pA} : 90dB(A)	K_{pA} =3.0dB(A)
A weighted sound power:	L_{wA} : 101dBA)	K_{wA} =3.0dB(A)
Wear ear protection when sound pressure is over		80dB(A)



ACCESSORIES

Auxiliary handle	1pc
Depth gauge	1pc
Dust cover	1pc
Spanner	1pc
Accessory kits:	25pcs
Drill bits(20pcs):	
5x100mm 2 pcs;	
6/8/10x110mm 2pcs for each size;	
6/8/10/12x160mm 2pcs for each size;	
8/10x200mm 1pc for each size	
12/14x250mm 1pc for each size	
Point chisel (2pcs):	
250mm 1pc	
150mm 1pc	
Flat chisels (3pcs):	
22 x 150mm 1pc	
22 x 250mm 1pc	
40 x 250mm 1pc	

1250W 6kg HAMMER DRILL

ERB575DRH

OPERATING INSTRUCTIONS



Note: Before using the tool, read the instruction book carefully.

Intended Use

The machine is intended for hammer drilling in concrete, brick and stone as well as for light chiseling work. It is also suitable for drilling without impact in wood, metal, ceramic and plastic.

1. ADJUSTING THE AUXILIARY HANDLE (See Fig. 1)

For your personal safety we recommend using the auxiliary handle at all times.

To adjust the handle, rotate the bottom of the handle anti-clockwise and rotate the handle around the hammer collar until the handle is in the desired position. Tighten fully.



Fig. 1

2. USING THE DEPTH GAUGE (See Fig. 1)

The depth gauge can be used to set a constant depth to the drill.

Rotate the locking screw on the top of the handle anti-clockwise to loosen, insert the depth gauge into the handle. Adjust it to the desired depth. Rotate the locking screw clockwise to tighten.

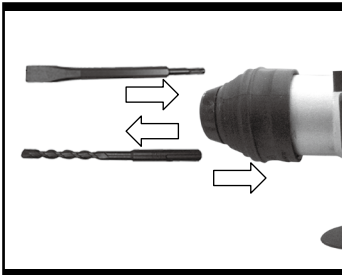

Fig. 2

3. FITTING BITS (See Fig. 2)

Clean the bit shank and apply grease before installing the bit. Hold the rotary grip, pull back the lock sleeve and insert the bits into the bit holder. Turn the bit and push it in until a resistance is felt. The shaft drops completely into the bit holder. Once you are satisfied that it has been seated, release the black lock sleeve. This would lock the bits into position.

After installing, always make sure that the tool is securely held in the bit holder by trying to pull it out. If the bits or chuck is not located well, repeat the operation again.

4. REMOVE BITS (See Fig. 2)

To remove the tool or chuck, pull back the lock sleeve, hold and pull the bit out.

Note: The bits are gripped firmly by the shank and can not be removed once locked in position.

5. OPERATING THE ON/OFF SWITCH (See Fig. 3)

Depress the switch to start the tool and release it to stop your tool.



Fig. 3

6. USING THE VARIABLE SPEED CONTROL (See Fig. 4)



The speed increases as you turn the switch towards the higher number and decreases on the lower number.

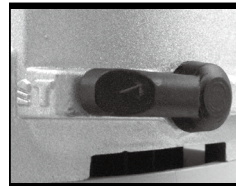
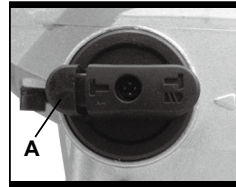

Fig. 4



7. FUNCTION MODE SELECTION

HAMMER DRILL FUNCTION

- 1) For drilling concrete, masonry etc, press the lock button (A) and rotate the selector switch to make sign “T” point to the triangle.
- 2) Turn the hammer or drilling action selector switch pointing to the hammer action “T” position.
- 3) You are now set up for hammer drilling into masonry.



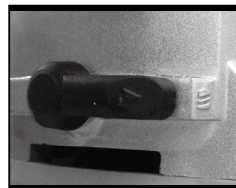
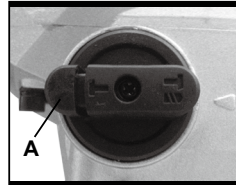

DRILLING FUNCTION

- 1) Press the lock button (A) and rotate the selector switch to make sign “T” point to the triangle.
- 2) Turn the hammer or drilling action selector switch pointing to the drilling action “D” position.
- 3) You are now set up for drilling function.

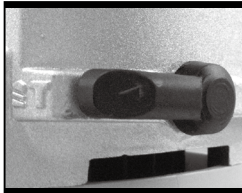
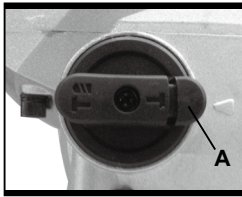



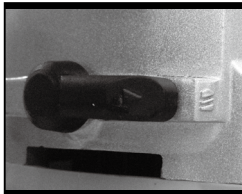
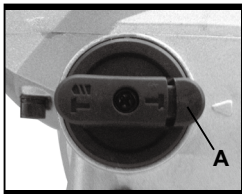

CHISEL FUNCTION

- 1) For chipping, grooving or demolition operation, press the lock button (A) and then rotate the selector switch make sign “” pointing to the triangle.
- 2) Turn the hammer or drilling action selector switch pointing to the hammer action “” position.
- 3) You are now set up for chisel work using Chisel action.



NO FUNCTION MODE:

- 1) Rotate the selector switch make sign “” pointing to the triangle.
- 2) Turn the hammer or drilling action selector switch pointing to the drilling action “” position.
- 3) The motor turns without load, the shaft will not turn.

 **Warning!** Do not set the switch like this. It may damage the motor greatly.

 **Warning:** You must make sure that the selector switch is positively locked in chisel mode position. If not, it could cause a hazard.



Fig. 5

8. DUST COVER (See Fig. 5)

Use the dust cover to prevent dust from falling over the tool and on your self when performing overhead drilling operations. Attach the dust cover to the bit as shown in the K.

9. LUBRICATION MACHINE (See Fig. 6)

The machine is grease-lubricated. A grease refill is only required during hammer work efficiency is low. Open the grease box lid at the top of the hammer using the pin spanner provided. Then refill approx 30g grease provided with your tool. The grease specification is general purpose lithium based. Use only Worx genuine hammer grease (optional accessory).

⚠ Caution: Keep the container of grease away from children.

10. TO REPLACE THE BRUSHES NOT PROVIDED (See Fig.7, 8)

Disconnect the plug from the power supply. Unscrew the carbon brush cap with screwdriver. Remove the carbon brush. Check the length of the brush and replace if under 6mm. When brushes need replacement always renew both brushes, even if one is still more than 6mm long.

Completely screw down the carbon brush cap. Check that the tool is working. Before use, allow it run for a few minutes to enable the brushes to settle.

⚠ Warning! The carbon brushes must be replaced by the manufacturer, its service agent or similarly qualified persons in order to avoid a hazard.

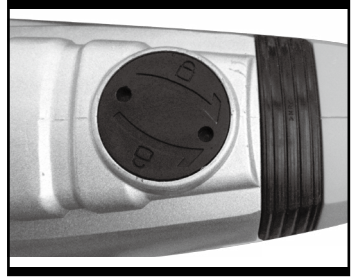

Fig. 6

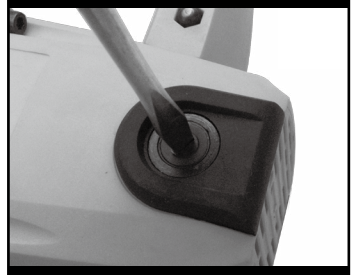

Fig. 7



Fig. 8

WORKING HINTS FOR YOUR TOOL

1. Reduce the pressure on the drill bit when it is about to break through. This will prevent the drill from jamming.
2. When drilling a large hole, first drill a pilot hole using a smaller drill bit.
3. Always apply pressure to your drill bit in a straight line, and if possible at right angles to the workpiece.
4. Never change the operating mode whilst the drill is running.
5. Do not apply excessive pressure to the tool when chiseling. Excessive force does not speed up the work.

MAINTENANCE

Remove the plug from the socket before carrying out any adjustment, servicing or maintenance.

There are no user serviceable parts in your power tool. Never use water or chemical cleaners to clean your power tool. Wipe clean with a dry cloth. Always store your power tool in a dry place. Keep the motor ventilation slots clean. Keep all working controls free of dust. Occasionally you may see sparks through the ventilation slots. This is normal and will not damage your power tool. If the supply cord is damaged, it must be replaced by the manufacturer, its service agent or similarly qualified persons in order to avoid a hazard.

TROUBLESHOOTING

1. If your power tool does not start, check the plug on the power supply first.
2. If your hammer becomes too hot in use, set the hammer switch to the drill mode and allow your drill to operate at maximum speed without load for 2 minutes.

3. If your hammer work efficiency is too low, please add sufficient grease in the grease box.
4. If your hammer use in low efficiency, please check whether the tool is blunt.
5. If a fault can not be rectified, return the tool to an authorized dealer for repair.

ENVIRONMENTAL PROTECTION

 Waste electrical products should not be disposed of with household waste. Please  recycle where facilities exist. Check with your Local Authority or retailer for recycling advice. For further information visit www.recycle-more.co.uk.

PLUG REPLACEMENT (UK & IRELAND ONLY)

If you need to replace the fitted plug then follow the instructions below.

IMPORTANT

The wires in the mains lead are coloured in accordance with the following code:

BLUE = NEUTRAL

Brown = Live

As the colours of the wires in the mains lead of this appliance may not correspond with the coloured markings identifying the terminals in your plug, proceed as follows. The wire which is coloured blue must be connected to the terminal which is marked with N. The wire which is coloured brown must be connected to the terminal which is marked with L.



Warning:

Never connect live or neutral wires to the earth terminal of the plug. **Only fit an approved 13AMP BS1363/A plug and the correct rated fuse.**

Note: If a moulded plug is fitted and has to be removed take great care in disposing of the plug and severed cable, it must be destroyed to prevent engaging into a socket.

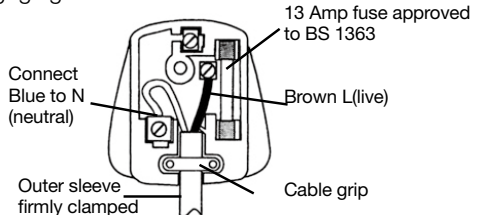

Erbauer®

DECLARATION OF CONFORMITY

We, Importer

Erbauer (UK) Ltd BA22 8RT

Declare that the product

Description: **6kg Hammer Drill**

Model: **ERB575DRH**

Complies with the following Directives,

EC Machinery Directive **2006/42/EC**

EC Low Voltage Directive **2006/95/EC**

EC Electromagnetic Compatibility Directive **2004/108/EC**

Restrictions of the Use of Certain Hazardous Substances in Electrical and Electronic Equipment **2011/65/EU**

Waste Electrical and Electronic Equipment (WEEE) **2012/19/EU**

Standards conform to:

EN 55014-1

EN 55014-2

EN 61000-3-2

EN 61000-3-3

EN 60745-1

EN 60745-2-6

Authorised Signatory and technical file holder

Date: 11/06/14

Signature: P. C. Harries

Name / title: Peter Harries / Quality Manager

Erbauer (UK) Ltd. Trade House, Mead Avenue, BA22 8RT



1250W 6kg HAMMER DRILL

ERB575DRH

Erbauer®