

# Erbauer®



**ERB562DRL**  
**ERA563DRL**

**2Year**  
Guarantee

**2kg HAMMER DRILL    ERB562DRL/ ERA563DRL**

Original Instructions  
(Version 1.0)

 **CAUTION**

This is a very powerful Drill.

When using this drill it is essential that the following rules for use are followed!

1. When drilling it is common that the core / drill bit jams in the material being drilled. This will result in the drill trying to rotate around the drill bit and potentially come out of your grip. This SDS Drill has a safety clutch mechanism. This safety clutch mechanism will be activated and stop the drive to the drill bit **BUT** only if you resist the initial forces caused by the jamming by securely holding the drill with both hands. As this is a very powerful drill these forces are significant.
2. **ALWAYS** ensure that the front handle is firmly affixed and secure.
3. The Front and rear handle must be firmly held to resist any movement of the drill when the core drill or drill bit becomes jammed.
4. **ALWAYS** use this drill when standing on a firm and secure platform or the ground. **(DO NOT USE ON LADDERS OR STEPS)**
5. **NEVER** Start the Drill with the core or drill jammed in position.
6. **DO NOT** stretch to hold the drill. Do not drill above shoulder height or below Knee height, as the drill cannot be securely held.
7. Never drill holes that are above the declared maximum size in the manual.
8. This drill is not designed for core drilling above the maximum capacity in masonry.

# Erbauer®

**Congratulations on your purchase of a quality power tool from Erbauer (UK) Ltd. This product should give you reliable service but for your peace of mind this **Erbauer** power tool does carry a 2 year guarantee, the terms of which are detailed below.**

**If this product develops a fault within the guarantee period contact your retailer.**

**Please retain this handbook in case you need to refer to safety, care or guarantee information in the future.**

## **GUARANTEE**

This **Erbauer** product carries a 2 year guarantee. If your product develops a fault within this period, you should in the first instance contact the retailer where the item was purchased.

This guarantee specifically excludes losses caused due to:

- Fair wear and tear
- Misuse or abuse
- Lack of routine maintenance
- Failure of consumable items (such as batteries)
- Accidental damage
- Cosmetic damage
- Failure to follow manufacturer's guidelines
- Loss of use of the goods

This guarantee does not affect your statutory rights. This guarantee is only valid in the UK.

For further technical advice, spare parts or repair service (outside of guarantee) please contact the customer helpline number on 0345 607 6380.

# GENERAL POWER TOOL SAFETY WARNINGS

 **Warning: Read all safety warnings and all instructions.** Failure to follow the warnings and instructions may result in electric shock, fire and/or serious injury.

## Save all warnings and instructions for future reference.

The term “power tool” in the warnings refers to your electric (corded) power tool or battery-operated (cordless) power tool.

### 1. Work area safety

**a. Keep work area clean and well lit.** Cluttered or dark areas invite accidents.

**b. Do not operate power tools in explosive atmospheres, such as in the presence of flammable liquids, gases or dust.** Power tools create sparks which may ignite the dust or fumes.

**c. Keep children and bystanders away while operating a power tool.** Distractions can cause you to lose control.

### 2. Electrical safety

**a. Power tool plugs must match the outlet. Never modify the plug in any way. Do not use any adapter plugs with earthed (grounded) power tools.** Unmodified plugs and matching outlets will reduce risk of electric shock.

**b. Avoid body contact with earthed or grounded surfaces, such as pipes, radiators, ranges and refrigerators.** There is an increased risk of electric shock if your body is earthed or grounded.

**c. Do not expose power tools to rain or wet conditions.** Water entering a power tool will increase the risk of electric shock.

**d. Do not abuse the cord. Never use the cord for carrying, pulling or unplugging the power tool. Keep cord away from heat, oil, sharp edges or moving parts.**

Damaged or entangled cords increase the risk of electric shock.

**e. When operating a power tool outdoors, use an extension cord suitable for outdoor use.** Use of a cord suitable for outdoor use reduces the risk of electric shock.

**f. If operating a power tool in a damp location is unavoidable, use a residual current device (RCD) protected supply.** Use of an RCD reduces the risk of electric shock.

### 3. Personal safety

**a. Stay alert, watch what you are doing and use common sense when operating a power tool. Do not use a power tool while you are tired or under the influence of drugs, alcohol or medication.** A moment of inattention while operating power tools may result in serious personal injury.

**b. Use personal protective equipment. Always wear eye protection.** Protective equipment such as dust mask, non-skid safety shoes, hard hat, or hearing protection used for appropriate conditions will reduce personal injuries.

**c. Prevent unintentional starting. Ensure the switch is in the off-position before connecting to power source and/or battery pack, picking up or carrying the tool.** Carrying power tools with your finger on the switch or energising power tools that have the switch on invites accidents.

**d. Remove any adjusting key or wrench before turning the power tool on.**

A wrench or a key left attached to a rotating part of the power tool may result in personal injury.

**e. Do not overreach. Keep proper footing and balance at all times.** This enables better control of the power tool in unexpected situations.

**f. Dress properly. Do not wear loose clothing or jewellery. Keep your hair, clothing and gloves away from moving parts.** Loose clothes, jewellery or long hair can be caught in moving parts.

**g. If devices are provided for the connection of dust extraction and collection facilities, ensure these are connected and properly used.** Use of dust collection can reduce dust-related hazards.

#### 4. Power tool use and care

**a. Do not force the power tool. Use the correct power tool for your application.** The correct power tool will do the job better and safer at the rate for which it was designed.

**b. Do not use the power tool if the switch does not turn it on and off.** Any power tool that cannot be controlled with the switch is dangerous and must be repaired.

**c. Disconnect the plug from the power source and/or the battery pack from the power tool before making any adjustments, changing accessories, or storing power tools.** Such preventive safety measures reduce the risk of starting the power tool accidentally.

**d. Store idle power tools out of the reach of children and do not allow persons unfamiliar with the power tool or these instructions to operate the power tool.**

Power tools are dangerous in the hands of untrained users.

**e. Maintain power tools. Check for misalignment or binding of moving parts, breakage of parts and any other condition that may affect the power tool's operation. If damaged, have the power tool repaired before use.** Many accidents are caused by poorly maintained power tools.

**f. Keep cutting tools sharp and clean.** Properly maintained cutting tools with sharp cutting edges are less likely to bind and are easier to control.

**g. Use the power tool, accessories and tool bits etc. in accordance with these instructions, taking into account the working conditions and the work to be performed.** Use of the power tool for operations different from those intended could result in a hazardous situation.

#### 5. Service

**a. Have your power tool serviced by a qualified repair person using only identical replacement parts.** This will ensure that the safety of the power tool is maintained.

## HAMMER SAFETY WARNINGS

- 1. Wear ear protectors.** Exposure to noise can cause hearing loss.
- 2. Use auxiliary handle(s), if supplied with the tool.** Loss of control can cause personal injury.
- 3. Hold power tool by insulated gripping surfaces, when performing an operation where the cutting accessory may contact hidden wiring or its own cord.** Cutting accessory contacting a "live" wire may make exposed metal parts of the power tool "live" and could give the operator an electric shock.
- 4. Always wear a dust mask.**
- 5. Connect the mains plug only when the tool is switched off. After using, pull the mains plug.**
- 6. Always direct the cable to the rear away from the machine.**
- 7. Persons under 16 years of age are not permitted to operate this machine.**

8. Keep the tool and accessories out of the reach of children.
9. Remove the plug from the socket before carrying out any adjustment, servicing or maintenance.
10. When an extension cable is required you must ensure it has the correct ampere rating for your power tool and that it is in a safe electrical condition. And please fully unwind cable drum extensions to avoid potential over heating.
11. Ensure your mains supply voltage is the same as your tool rating plate voltage.
12. Your tool is double insulated for additional protection against a possible electrical insulation failure within the tool.
13. Always check walls and ceilings to avoid hidden power cables and pipes.
14. After long working periods, external metal parts and accessories could be hot.
15. Wear eye protection when operating this tool.
16. Your hand must hold on the handle when you are working. Always use the auxiliary handles supplied with the tool. Loss of control can cause personal injury.

## **ADDITIONAL SAFETY WARNING FOR CONSTRUCTION DUST**

The updated Control of Substances Hazardous to Health Regulations 1st October 2012 now also targets to reduce the risks associated with silica, wood and gypsum dusts. Construction workers are one of the at-risk groups within this because of the dust that they breathe: silica dust is not just a nuisance; it is a real risk to your lungs!

Silica is a natural mineral present in large amounts in things like sand, sandstone and granite. It is also commonly found in many construction materials such as concrete and mortar. The silica is broken into very fine dust (also known as Respirable Crystalline Silica or RCS) during many common tasks such as cutting, drilling and grinding

Breathing in very fine particles of crystalline silica can lead to the development of:

Lung cancer

Silicosis

Chronic Obstructive Pulmonary Disorder (Chronic obstructive pulmonary disease (COPD))

And breathing in fine particles of wood dust can lead to the development of Asthma

The risk of lung disease is linked to people who regularly breathe construction dust over a period of time, not on the odd occasion.

To protect the lung, the COSHH Regulations sets a limit on the amount of these dusts that you can breathe (called a Workplace Exposure Limit or WEL) when averaged over a normal working day. These limits are not a large amount of dust: when compared to a penny it is tiny – like a small pinch of salt:

This limit is the legal maximum; the most you can breathe after the right controls have been used.

How to reduce the amount of dust?

1. Reduce the amount of cutting by using the best sizes of building products.
2. Use a less powerful tool e.g. a block cutter instead of angle grinder.

3. Using a different method of work altogether – e.g. using a nail gun to direct fasten cable trays instead of drilling holes first.

Please always work with approved safety equipment, such as those dust masks that specially designed to filter out microscopic particles and use the dust extraction facility at all time.

For more information please see the HSE website:

<http://www.hse.gov.uk/construction> or <http://www.hse.gov.uk/pubns/cis69.pdf>

 **Warning: Some dust particles created by power sanding, sawing, grinding, drill and other construction jobs contain chemicals known to cause cancer, birth defects or other reproductive harm.** Some examples of these chemicals are:

- Lead from lead-based paints.
- Crystalline silica from bricks and cement and other masonry products.
- Arsenic and chromium from chemically treated timber.

Your risk from these exposures varies, depending upon how often you do this type of work. To reduce your exposure to these chemicals:

- Work in a well-ventilated area.
- Work with approved safety equipment, such as those dust masks that are specially designed to filter microscopic particles.



# VIBRATION

The European Physical Agents (Vibration) Directive has been brought in to help reduce hand arm vibration syndrome injuries to power tool users. The directive requires power tool manufacturers and suppliers to provide indicative vibration test results to enable users to make informed decisions as to the period of time a power tool can be used safely on a daily basis and the choice of tool.

Further Advice can be found at [www.hse.gov.uk](http://www.hse.gov.uk)

## ERB562DRL:

Vibration total values (triax cover sum) determined according to EN60745:	
Hammer drilling into concrete	Vibration emission value $\alpha_{h,HD}=23.287\text{m/s}^2$ (for main handle) $\alpha_{h,HD}=20.137\text{m/s}^2$ (for auxiliary handle)
	Uncertainty $K = 1.5\text{m/s}^2$
Chiselling	$\alpha_{h,CHeq}=20.712\text{m/s}^2$ (for main handle) $\alpha_{h,CHeq}=18.085\text{m/s}^2$ (for auxiliary handle)
	Uncertainty $K=1.5\text{m/s}^2$

## ERA563DRL:

Vibration total values (triax cover sum) determined according to EN60745:	
Hammer drilling into concrete	Vibration emission value $\alpha_{h,HD}=24.834\text{m/s}^2$ (for main handle) $\alpha_{h,HD}=23.235\text{m/s}^2$ (for auxiliary handle)
	Uncertainty $K = 1.5\text{m/s}^2$
Chiselling	$\alpha_{h,CHeq}=22.457\text{m/s}^2$ (for main handle) $\alpha_{h,CHeq}=19.778\text{m/s}^2$ (for auxiliary handle)
	Uncertainty $K=1.5\text{m/s}^2$

The declared vibration emission value should be used as a minimum level and should be used with the current guidance on vibration.

Calculating the actual period of the actual period off use can be difficult and the HSE website has further information.

The declared vibration emission been measured in accordance with a standardised test stated above and may be used to compare one tool with another tool.

The declared vibration emission value may also be used in a preliminary assessment of exposure.

 **Warning:** The vibration emission value during actual use of the power tool can differ from the declared value depending on the ways in which the tool is used dependant on the following examples and other variations on how the tool is used:

How the tool is used and the materials being cut or drilled.

The tool being in good condition and well maintained

The use of the correct accessory for the tool and ensuring it is sharp and in good condition.  
The tightness of the grip on the handles.  
And the tool is being used as intended by its design and these instructions.

**While working with this power tool, hand/arm vibrations occur. Adopt the correct working practices in order to reduce the exposure to vibration.**

**This tool may cause hand-arm vibration syndrome if its use is not adequately managed.**

 **Warning:** identify safety measures to protect the operator that are based on an estimation of exposure in the actual conditions of use (taking account of all parts of the operating cycle such as the times when the tool is switched off and when it is running idle in addition to the trigger time). Note The use of other tools will reduce the users' total working period on this tool.

Helping to minimise your vibration exposure risk.

ALWAYS use sharp chisels, drills and blades

Maintain this tool in accordance with these instructions and keep well lubricated (where appropriate)

Avoid using tools in temperatures of 10°C or less

Plan your work schedule to spread any high vibration tool use across a number of days.

### **Health Surveillance**

All employees should be part of an employer's health surveillance scheme to help identify any vibration related diseases at an early stage, prevent disease progression and help employees stay in work.

### **Double insulation**

The tool is double insulated. This means that all the external metal parts are electrically insulated from the mains power supply. This is done by placing insulation barriers between the electrical and mechanical components making it unnecessary for the tool to be earthed.

### **Important note**

Be sure the supply is the same as the voltage given on the rating plate. The tool is fitted with a two-core cable and plug.

Remove the mains plug from socket before carrying out, any adjustment or servicing.

### **Torque limiter**

There is a clutch in your rotary hammer drill.

The torque limiter will actuate when a certain torque level is reached. The motor will disengage from the output shaft. When this happens, the bit will stop turning.

As soon as the torque limiter actuates, switch off the tool immediately and remove the drill bit from the hole completely. This will help prevent premature wear of the tool.

## SYMBOLS



To reduce the risk of injury, user must read instruction manual



Warning



Double insulation



Wear ear protection



Wear eye protection



Wear dust mask



Wear safety gloves



Waste electrical products should not be disposed of with household waste.  
Please recycle where facilities exist. Check with your Local Authority  
or retailer for recycling advice.

yyWxx Manufacturing date code; Year of manufacturing (20yy) and week of manufacturing (Wxx);



- 
1. ADJUSTABLE DEPTH GAUGE

---

  2. DUST PROTECTION CAP

---

  3. TOOL HOLDER LOCKING SLEEVE

---

  4. FUNCTION MODE SELECTION SWITCH

---

  5. FORWARD AND REVERSE ROTATION CONTROL

---

  6. SWITCH LOCK-ON BUTTON

---

  7. ON/OFF SWITCH WITH VARIABLE SPEED CONTROL

---

  8. AUXILIARY HANDLE
-

## TECHNICAL DATA

	ERB562DRL	ERA563DRL
Rated Voltage	230-240V~ 50Hz	110V~ 50Hz
Rated power	710W	
Rated No-load speed	0-1050/min	
Impact rate	0-4600bpm	
Impact energy	2.5J	
Protection class	□/II	
Drilling capacity max		
	Masonry	22mm
	Steel	13mm
	Wood	30mm
Weight	2.7kg	

## NOISE INFORMATION

### ERB562DRL

A weighted sound pressure  $L_{pA}$ : 97.7dB(A)  $K_{pA}$ =3.0dB(A)

A weighted sound power  $L_{wA}$ : 108.7dB(A)  $K_{wA}$ =3.0dB(A)

Wear ear protection when sound pressure is over 80dB(A)



### ERA563DRL

A weighted sound pressure  $L_{pA}$ : 97.7dB(A)  $K_{pA}$ =3.0dB(A)

A weighted sound power  $L_{wA}$ : 108.7dB(A)  $K_{wA}$ =3.0dB(A)

Wear ear protection when sound pressure is over 80dB(A)



## ACCESSORIES

Auxiliary handle

1pc

Depth gauge

1pc

**2kg HAMMER DRILL ERB562DRL/ ERA563DRL**

# OPERATING INSTRUCTIONS



**Note:** Before using the tool, read the instruction book carefully.

## Intended Use

The machine is intended for hammer drilling in concrete, brick and stone as well as for light chiseling work. It is also suitable for drilling without impact in wood, metal, ceramic and plastic.

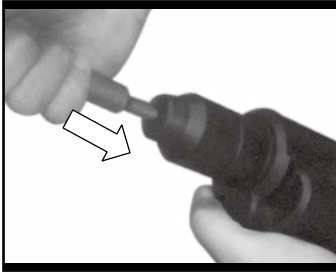

**Fig. 1-1**

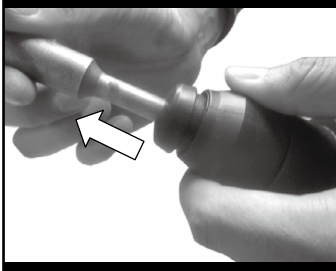

**Fig. 1-2**



**Fig. 2**



**Fig. 3**

## 1. INSERTING AND REMOVING DRILL BIT IN SDS

Take care that the dust protection cap (2) is not damaged when changing tools.

### • Inserting (See Fig. 1-1)

Clean and lightly oil the bit before inserting. Insert the dust-free bit into the bit holder with a twisting motion until it latches.

The bit locks itself. Check the locking by pulling on the tool.

### • Removing (See Fig. 1-2)

Retract back the bit holder locking sleeve (3) and pull out the bit.



**Warning:** Your new Rotary Hammer generates powerful forces to get your job done quickly and effectively. These forces may cause inferior quality SDS bits to break and jam in the chuck. We therefore recommend that only high quality SDS bits be used with this tool.

## 2. ON/OFF SWITCH WITH VARIABLE SPEED CONTROL (See Fig. 2)

Depress to start and release to stop your tool. This tool has a variable speed switch (7) that delivers higher speeds with increased trigger pressure - speed is controlled by varying the pressure applied to the switch.

## 3. SWITCH LOCK-ON BUTTON

Depress the on/off switch (7) then the lock on button (6) (See Fig. 2); release the on/off switch first and the lock-on button second. Your switch is now locked on for continuous use. To switch off your tool just depress and release the on/off switch.

## 4. AUXILIARY HANDLE (See Fig. 3)

Slide the handle onto the hammer and rotate to the desired working position. To clamp the auxiliary handle rotate the handle clockwise. To loosen the auxiliary handle, rotate the handle anti-clockwise.

**Warning:** Always use the auxiliary handle.

## 5. FORWARD AND REVERSE ROTATION CONTROL

With the drill pointing away from you, push the forward/reverse-lever (5) to the left “←” for forward rotation. Push the forward/reverse-lever (5) to the right for reverse rotation “→”.

**Warning:** Never change the direction of rotation while the tool is rotating, wait until it has stopped.

## 6. ADJUSTABLE DEPTH GAUGE

Fit the drill bit into the chuck. Loosen the depth gauge by rotating the auxiliary handle anti-clockwise. Slide the depth gauge until the distance between the depth gauge end and the drill bit end is equal to the depth of hole/screw you wish to make. Then clamp the depth gauge by rotating the handle clockwise.

## 7. FUNCTION MODE SELECTION (See Fig. 4)

The operation of the gearbox for each application is set with the function mode selection switch (4). To change between functions, depress the unlocking button (12) and rotate the selector to the desired operating mode.

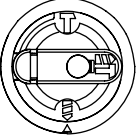
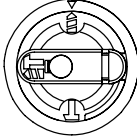
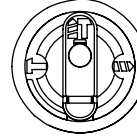
	For impacting only - for light chipping, chiseling and demolition applications choose the Hammer position.
	For drilling into steel, wood and plastics choose the Rotary drilling position.
	For simultaneous drilling and impacting of concrete or masonry, choose the Hammer drilling position.

**Warning:** The operating mode selector switch may be actuated only at a standstill.

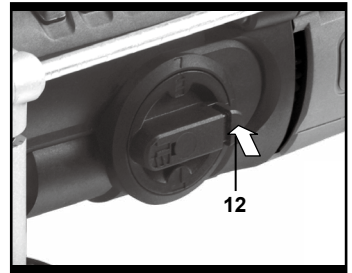

**Fig. 4**

## **WORKING HINTS FOR YOUR DRILL (HAMMER)**

If your power tool becomes over heated, set the speed to maximum and run no load for 2-3 minutes to cool the motor. SDS-plus tungsten carbide drill bits should always be used for concrete and masonry. When drilling in metal, only use HSS drill bits in good condition. Where possible use a pilot hole before drilling a large diameter hole.

## **MAINTENANCE**

Remove the plug from the socket before carrying out any adjustment, servicing or maintenance.

Your power tool requires no additional lubrication or maintenance. There are no user serviceable parts in your power tool. Never use water or chemical cleaners to clean your power tool. Wipe clean with a dry cloth. Always store your power tool in a dry place. Keep the motor ventilation slots clean. Keep all working controls free of dust. Occasionally you may see sparks through the ventilation slots. This is normal and will not damage your power tool.

If the supply cord is damaged, it must be replaced by the manufacturer, its service agent or similarly qualified persons in order to avoid a hazard.

## **ENVIRONMENTAL PROTECTION**



Waste electrical products should not be disposed of with household waste. Please  recycle where facilities exist. Check with your Local Authority or retailer for recycling advice. For further information visit [www.recycle-more.co.uk](http://www.recycle-more.co.uk).



# PLUG REPLACEMENT (UK & IRELAND ONLY)

If you need to replace the fitted plug then follow the instructions below.

## IMPORTANT

The wires in the mains lead are coloured in accordance with the following code:

### BLUE = NEUTRAL

### Brown = Live

As the colours of the wires in the mains lead of this appliance may not correspond with the coloured markings identifying the terminals in your plug, proceed as follows. The wire which is coloured blue must be connected to the terminal which is marked with N. The wire which is coloured brown must be connected to the terminal which is marked with L.



### Warning:

Never connect live or neutral wires to the earth terminal of the plug. **Only fit an approved 13AMP BS1363/A plug and the correct rated fuse.**

**Note:** If a moulded plug is fitted and has to be removed take great care in disposing of the plug and severed cable, it must be destroyed to prevent engaging into a socket.

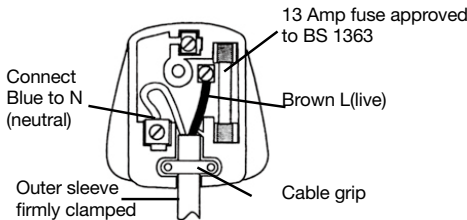

# Erbauer®

## DECLARATION OF CONFORMITY

We, Importer

**Erbauer (UK) Ltd BA22 8RT**

Declare that the product

Description: **2kg Hammer Drill**

Model: **ERB562DRL/ERA563DRL**

Complies with the following Directives,

EC Machinery Directive **2006/42/EC**

EC Low Voltage Directive **2006/95/EC**

EC Electromagnetic Compatibility Directive **2004/108/EC**

Restrictions of the Use of Certain Hazardous Substances in Electrical and Electronic Equipment **2011/65/EU**

Waste Electrical and Electronic Equipment (WEEE) **2012/19/EU**

Standards conform to:

**EN 60745-1**

**EN 60745-2-6**

**EN 55014-1**

**EN 55014-2**

**EN 61000-3-2**

**EN 61000-3-3**

### Authorised Signatory and technical file holder

Date: 11/06/14

Signature: P. C. Harries

Name / title: Peter Harries / Quality Manager

Erbauer (UK) Ltd. Trade House, Mead Avenue, BA22 8RT





**Erbauer®**