

TITAN[®]

650W Tile Cutter

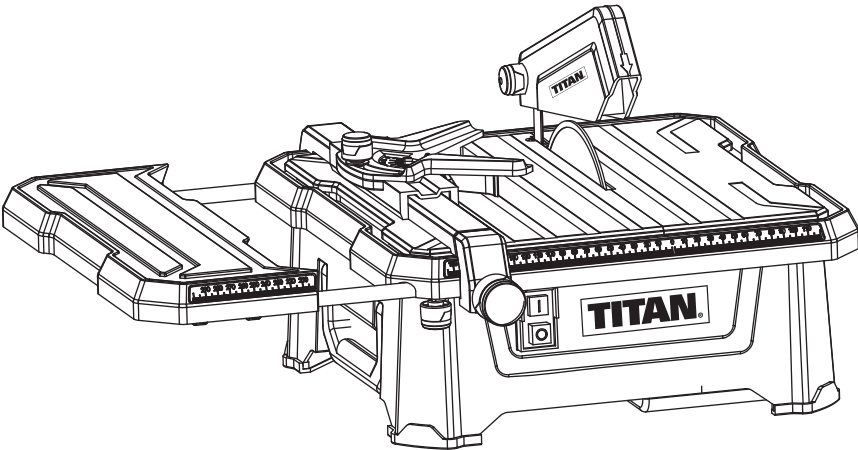

TTB597TCB

Barcode: 5052931305766



WARNING! Read the instructions before using the product!

TITAN®

Congratulations on your purchase of a TITAN power tool from TITAN Power Tools (UK) Ltd. We want you to continue getting the best performance from it so this handbook includes information on safety, handling and care. Please retain this handbook in case you need to refer to any of the information in the future. Your TITAN power tool comes with a 2 year guarantee, so should it develop a fault within this period contact your retailer.

GUARANTEE



This TITAN product carries a 2 year guarantee. If your product develops a fault within this period, you should, in the first instance contact the retailer where the item was purchased. This guarantee specifically excludes losses caused due to:

- Fair wear and tear
- Misuse or abuse
- Lack of routine maintenance
- Failure of consumable items (such as batteries)
- Accidental damage
- Cosmetic damage
- Failure to follow manufacturer's guidelines
- Loss of use of the goods

This guarantee does not affect your statutory rights. This guarantee is only valid in the UK.

650W TILE CUTTER

TTB597TCB

Let's get started...

These instructions are for your safety. Please read through them thoroughly before use and retain them for future reference.



Getting **started**... 03

Your product	04
Technical and legal information	06
Before you start	12



In more **detail**... 22

Product functions	23
Care and maintenance	27
Trouble shooting	33
Recycling and disposal	34
EC declaration of conformity	35

Your product

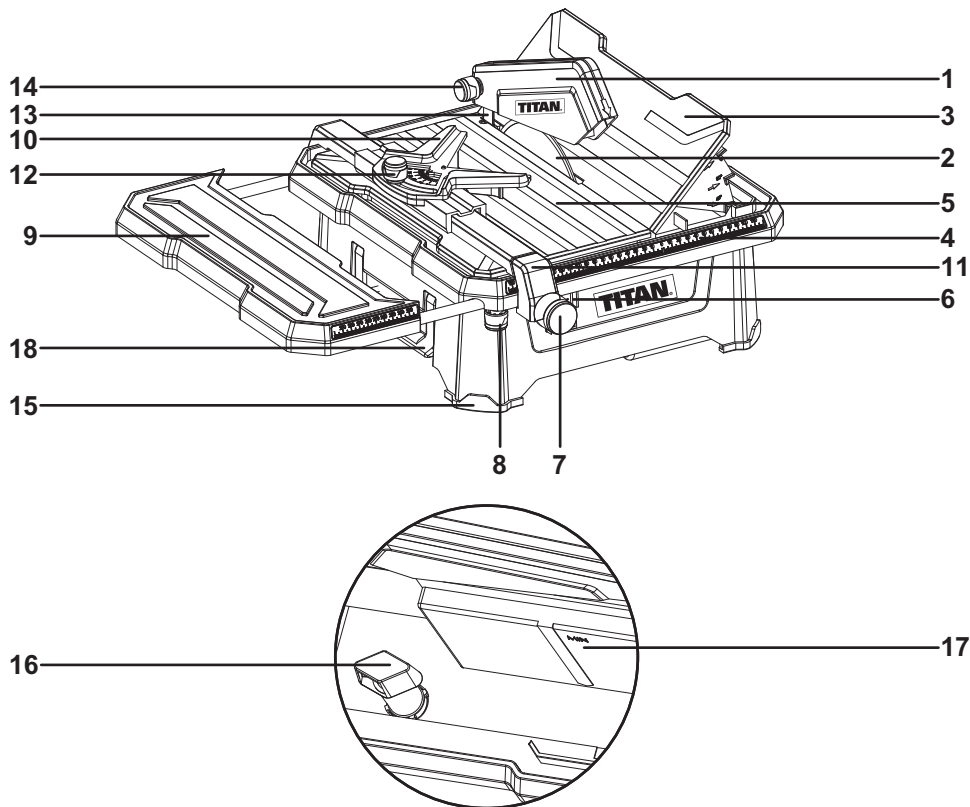

Getting started....

- | | |
|--|--|
| 1. Upper protective guard | 11. Parallel cutting guide |
| 2. Cutting disc | 12. Locking knob
(for mitre cutting guide) |
| 3. 45° Vertical fence | 13. Metal bracket |
| 4. Scale | 14. Locking knob
(for upper protective guard) |
| 5. Working table | 15. Absorption pad |
| 6. On/Off switch | 16. Water reservoir plug |
| 7. Locking knob
(for parallel cutting guide) | 17. Lower protective guard |
| 8. Locking knob
(for locking extension table) | 18. Transportation handle |
| 9. Extension table | |
| 10. Mitre cutting guide | |

Safety devices

Metal bracket

The metal bracket (13) prevents a workpiece being caught by the cutting disc (2) and being hurled at the operator.

The metal bracket must always be mounted during operation.

Upper protective guard

The upper protective guard (1) prevents accidental contact with the cutting disc (2) and stops workpiece parts and cooling water from being flung out.

The upper protective guard must always be mounted during the operation and can be lowered to the workpiece.

Lower protective guard

The lower protective guard (17) prevents accidental contact with the cutting disc (2) and stops workpiece parts and cooling water from being flung out.

The lower cutting disc cover must always be mounted during operation.

Technical specifications

General

- > **Input Voltage** : 230-240V~50Hz
- > **Power Input** : 650W
- > **No Load Speed** : 5500min⁻¹
- > **Insulation Class** : Class I
- > **Diamond Disc Size** : $\varnothing 180\text{mm} \times 2.4\text{mm} \times \varnothing 22.2\text{mm}$
- > **Table Size** : 345x345mm
- > **Table Size (with Extension Table)** : 400x510mm
- > **Extension Table Width** : 120mm
- > **Maximum Extension Range** : 150mm
- > **Table Tilt Range** : 0°/15°/30°/45°
- > **Maximum Cutting Depth** : 30mm (90°) / 27mm (15°)
25mm (30°) / 17mm (45°)
- > **Net Weight** : 7.6kg

NOISE

A weighted sound pressure L_{pA}	96.9dB(A)
A weighted sound pressure L_{WA}	107dB(A)
Uncertainty.....	3dB(A)

The sound intensity level for the operator may exceed 85dB(A) and sound protection measures are necessary.

Important note

Remove the mains plug from socket before carrying out any adjustment or servicing.

Ensure your mains supply voltage is the same as your tool rating plate voltage.

Symbols

On the product, the rating label and within these instructions you will find among others the following symbols and abbreviations.

Familiarise yourself with them to reduce hazards like personal injuries and damage to property.

V~	Volt	Hz	Hertz
W	Input power	kg	Kilogram
min ⁻¹	Per minute	dB(A)	Decibel (A-rated)
yyWxx	Manufacturing date code; year of manufacturing (20yy) and week of manufacturing (Wxx);		



Caution / Warning.



Wear hearing protection.



Read the instruction manual.



Wear eye protection.



Wear gloves.



Wear respiratory protection.



Caution, risk of cutting.



Use only non fragmented discs.



Switch the product off and disconnect it from the power supply before assembly, cleaning, adjustments, maintenance, storage and transportation.



The product complies with the applicable European directives and an evaluation method of conformity for these directives was done.



WEEE symbol. Waste electrical products should not be disposed of with household waste. Please recycle where facilities exist.

Check with your Local Authority or local store for recycling advice.

Safety warnings

GENERAL SAFETY INSTRUCTIONS



WARNING! To ensure safe operation when using your Tile Cutter, make sure you follow basic safety principles to reduce risk of personal injury, electric shock and fire. Please read the following instructions prior to operating this product and keep for future use.

SAVE THESE INSTRUCTIONS

1. Keep the work area clean.

> Cluttered and dark areas invite accidents.

2. Consider work area environment.

> Do not expose power tools to rain. Do not use power tools in damp or wet

locations. Keep the work area well lit. Do not use tools in the presence of flammable liquids or gases.

3. Guard against electric shock.

- > Avoid body contact with earthed or grounded surfaces (e.g. pipes, radiators, ranges, refrigerators).

4. Keep children away.

- > Do not let persons, especially children, not involved in the work touch the tool or the extension cord and keep them away from the work area.

5. Store idle tools.

- > When not in use, tools should be stored in a dry, high or locked up place, out of reach of children.

6. Do not force the tool.

- > It will do the job better and safer at the rate for which it was intended.

7. Use the right tool.

- > Do not force small tools to do the job of a heavy-duty tool. Do not use tools for purposes not intended, for example, do not use circular saws to cut tree limbs or logs.

8. Dress properly.

- > Do not wear loose clothing or jewellery, they can be caught in moving parts. Non-skid footwear are recommended when working outdoors. Wear protective hair covering to contain long hair.

9. Use protective equipment.

- > Use safety glasses. Use face or dust mask if working operations create dust.

10. Connect dust extraction equipment.

- > If the tool is provided for the connection of dust extraction and collecting equipment, ensure these are connected and properly used.

11. Do not abuse the cord.

- > Never yank the tool to disconnect it from the socket. Keep the cord away from heat, oil and sharp edges.

12. Secure work.

- > Where possible use clamps or a vice to hold the work. It is safer than using your hand.

13. Do not overreach.

- > Keep proper footing and balance at all times.

14. Maintain tool with care.

- > Keep cutting tools sharp and clean for better and safer performance. Follow instructions for lubrication and changing accessories. Inspect tool cord periodically and if damaged have them replaced by an authorised service facility. Inspect extension cords periodically and replace if damaged. Keep handles dry, clean and free of oil or grease.

15. Disconnect tools.

- > When not in use, before servicing and when changing accessories such as blades, bits and cutters, disconnect tools from the power supply.

16. Remove adjusting keys and wrenches.

- > From the habit of checking to see that keys and adjusting wrenches are removed from the tool before turning it on.

17. Avoid unintentional starting.

- > Ensure switch is in the "off" when plugging in.

18. Use outdoor extension leads.

- > When tool is used outdoors, use only extension cords intended for outdoor use and so marked.

19. Stay alert.

- > Watch what you are doing. Use common sense. Do not operate tool when you are tired.

20. Check damaged parts.

- > Before further use of the tool, it should be carefully checked to determine that it will operate properly and perform its intended function. Check for alignment of moving parts, binding of moving parts, breakage of parts, mounting and any other conditions that may affect its operation. A guard or other part that is damaged should be properly repaired or replaced by an authorised service centre unless otherwise indicated in this instruction manual. Have defective switches replaced by an authorised service facility. Do not use the tool if the switch does not turn it on and off.

21. Warning.

- > The using of any accessory or attachment other than those recommended in this instruction manual may present a risk of personal injury.

22. Have your tools repaired by qualified person.

- > This electrical tool complies with the relevant safety requirements. Repairs should only be carried out by qualified persons using original spare parts, otherwise this may result in considerable danger to the user.

HEALTH ADVICE

Warning! When drilling, sanding, sawing or grinding, dust particles will be produced. In some instances, depending on the materials you are working with, this dust can be particularly harmful to you (e.g. lead from old gloss paint). You are advised to consider the risks associated with the materials you are working with and to reduce the risk of exposure. You should:

- Work in a well-ventilated area.
- Work with approved safety equipment, such as those dust masks that are specially designed to filter microscopic particles.

ADDITIONAL SAFETY INSTRUCTIONS FOR YOUR TOOLS

- > Do not use diamond discs which are damaged or deformed.
- > Replace table insert when worn.
- > Use only diamond discs recommended by the manufacturer.
- > Take care that the selection of the diamond discs is suitable for the material to be cut.
- > Wear suitable personal protective equipment when necessary, this could include hearing protection to reduce the risk of induced hearing loss, respiratory protection to reduce the risk of inhalation of harmful dust, wear gloves when handling diamond discs and rough material.
- > Never use blades on this machine.
- > Use only diamond discs for which the maximum possible speed is not less than the maximum spindle speed of the tool and the material to be cut.
- > Faults in the machine, including guards or diamond discs, should be reported as soon as they are discovered. Never use the machine without the guard in position.
- > Maximum size of working piece should be 1m².
- > This tile cutter should be used with limitations on ambient conditions (between 15°C and 30°C).
- > The machine must be supplied through a residual current device (RCD) having a rated residual operating current not exceeding 30 mA.

Wear goggles

Wear ear defenders

Wear a breathing mask

Unpack

- > Unpack all parts and lay them on a flat, stable surface.
- > Remove all packing materials and shipping devices if applicable.
- > Make sure the delivery contents are complete and free of any damage. If you find that parts are missing or show damage do not use the product but contact your dealer. Using an incomplete or damaged product represents a hazard to people and property.
- > Ensure that you have all the accessories and tools needed for assembly and operation. This also includes suitable personal protective equipment.

You will need

(items not supplied)

- > Suitable personal protective equipment
- > Phillips screwdriver

(items supplied)

- > Disc spanner 13mm x 5.9mm (2 pc)



WARNING: Risk of injury!

Always pull out the mains plug (disconnect the product from its power supply) before commencing work on the product.

Fitting the cutting disc



WARNING: Product damage!

Be sure to observe the rotational direction of the cutting disc when fitting! Be sure to observe the free-wheeling of the cutting disc when fitting!



NOTE: When fitting make sure that the cutting disc is placed correctly on the inner flange. The inner flange can be moved freely on the motor shaft and has a section for holding the internal hole of the cutting disc. The hole of the outer flange is not round and is used for the interlocking connection with the motor shaft.

- > Unplug the tile cutter from the mains supply.
- > Raise the 45° Vertical fence (3) approx. 45° and remove.

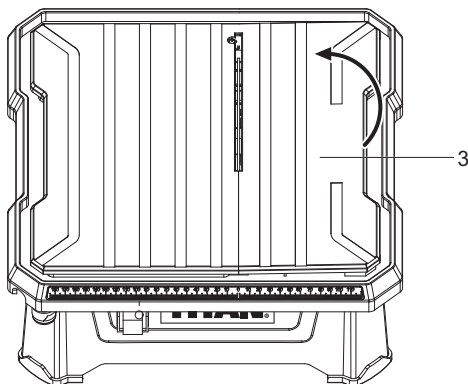

Fig. 1

- > Loosen cross-screws (19) with the Phillips screwdriver (not supplied) and pull off lower protective guard (17).

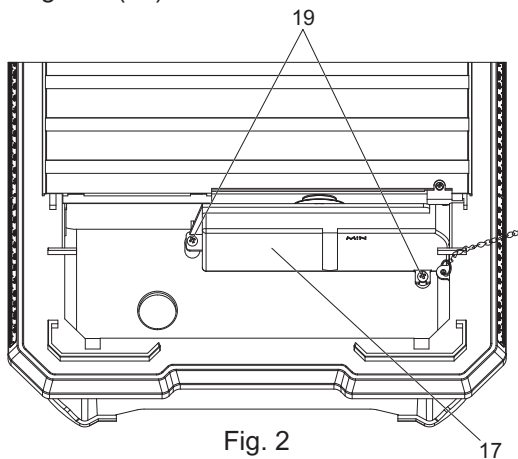

Fig. 2

- > Attach the straight spanner (20) (supplied) to the hexagon nut (21).
- > Lock motor shaft (25) to prevent turning using angled spanner (23) (supplied).
- > Turn the hexagon nut (21) anti-clockwise.
- > Remove the hexagon nut (21) and outer flange (22).

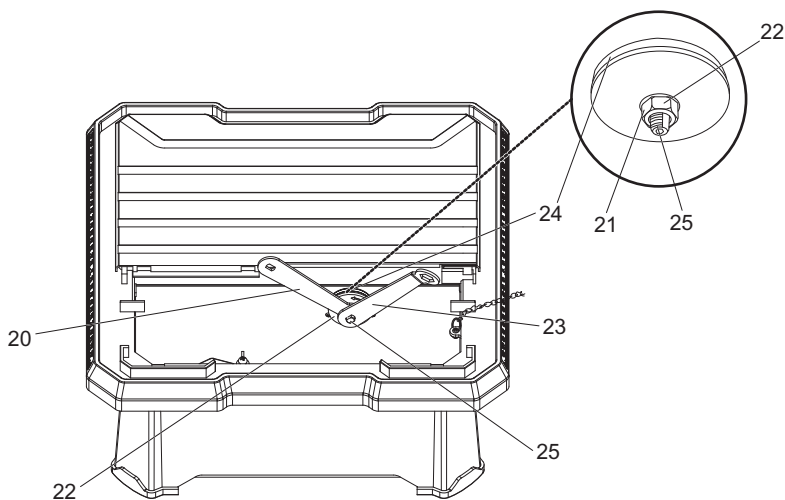

Fig. 3

- > Place cutting disc (2) on inner flange (24).
- > Attach the outer flange (22).
- > Screw hexagon nut (21) onto motor shaft (25) clockwise.
- > Attach the straight spanner (20) to the hexagon nut (21).
- > Lock motor shaft (25) to prevent turning using angle spanner (23).
- > Tighten hexagon nut (21) clockwise using straight spanner (20).
- > Re-attach the lower protective guard (17) and tighten cross-screws (19).
- > Replace the 45° vertical fence (3).

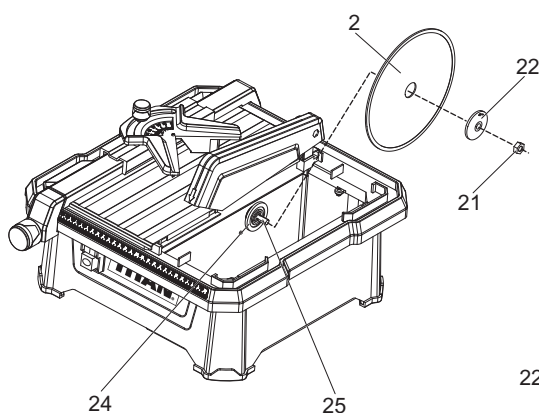

Fig. 4

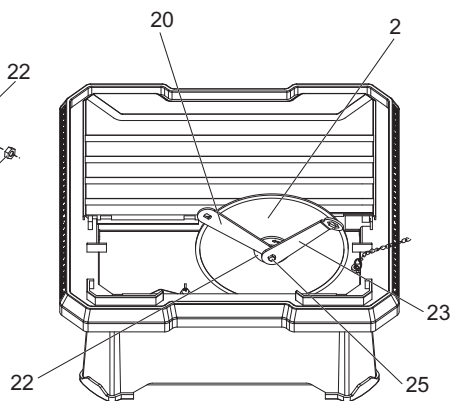

Fig. 4-1

Assemble/adjust metal bracket



WARNING: Product damage!

The metal bracket must always be aligned parallel to the cutting disc.

- > Unplug the tile cutter from the mains supply.
- > Raise the 45° Vertical fence (3) approx. 45° and remove.

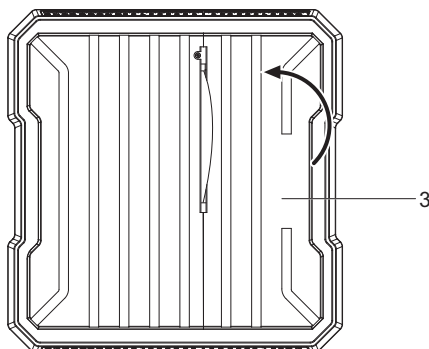

Fig. 5

- > Loosen the cross-screw (26) with the Phillips screwdriver (not supplied).
- > Push slotted hole in the metal bracket (13) below the cross-screw (26).
- > Gently tighten the cross-screw (26).
- > Align metal bracket (13) with the cutting disc (2).
- > Tighten cross-screw (26) with a Phillips screwdriver (not supplied).
- > Replace the 45° vertical fence (3).

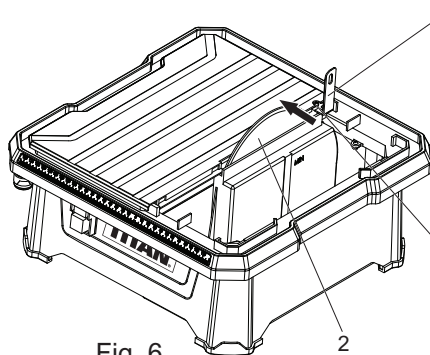

Fig. 6

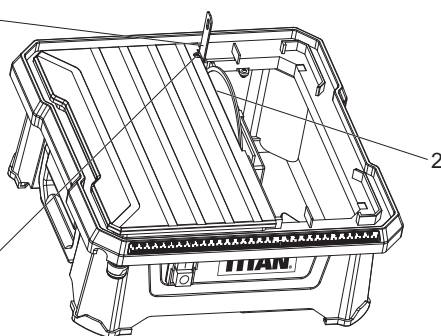

Fig. 6-1

Mounting the upper protective guard to the metal bracket



WARNING: Product damage!

Do not over-tighten socket head bolt (27) and locking knob (14). The upper protective guard (1) must be free to rise and fall as the workpiece is pushed towards the cutting disc.

- > Unplug the tile cutter from the mains supply.
- > Push the upper protective guard (1) onto the metal bracket (13).
- > Push socket head bolt (27) through upper protective guard (1) and metal bracket (13).
- > Push the flat washer (28) onto socket head bolt (27).
- > Screw and tighten locking knob (14) onto socket head bolt (27).
- > Cover the cutting disc with the upper protective guard (1).
- > Ensure that upper protective guard (1) can move freely and that it cannot touch the cutting disc.

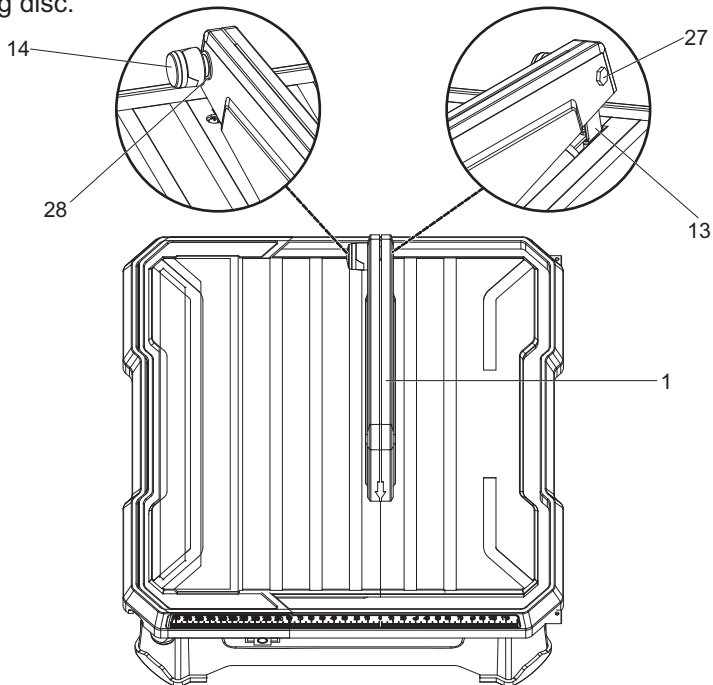

Fig. 7

Mounting the extension table

- > Unplug the tile cutter from the mains supply.
- > Undo the cross-screws(29).
- > Push the guide rails for the extension table (9) on both sides into the locator (30) of the machine body.
- > Refit the cross-screws (29).
- > Mounting the locking knob (8).

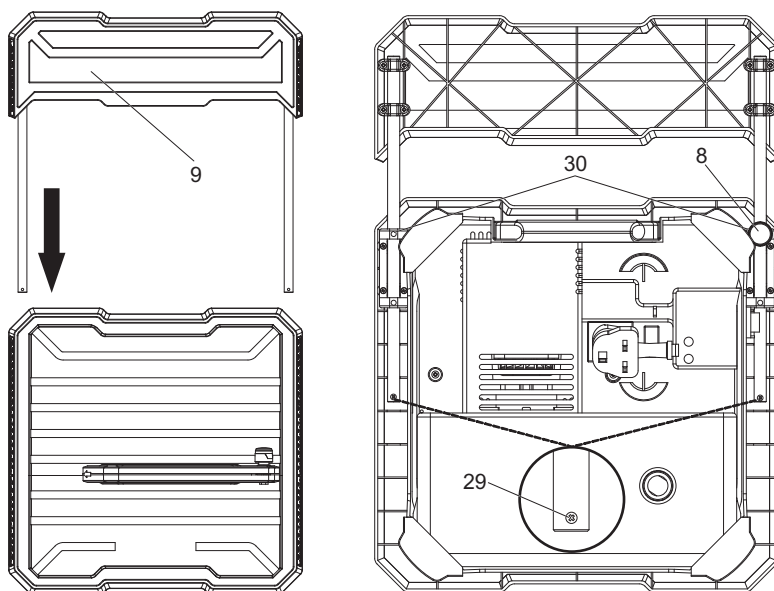

Fig. 8

Setting the extension table

- > Unplug the tile cutter from the mains supply.
- > Loosen the locking knob (8).
- > Set the extension table (9) to the desired distance from the cutting disc.
- > Tighten the locking knob (8).

Mounting the parallel cutting guide

- > Unplug the tile cutter from the mains supply.
- > Attach the rear end of the parallel cutting guide (11) to the rear of the working table (5).
- > Push the spring (31), clamp (32) and washer (33) onto thread (34).
- > Screw locking knob (7) onto thread (34) and tighten.

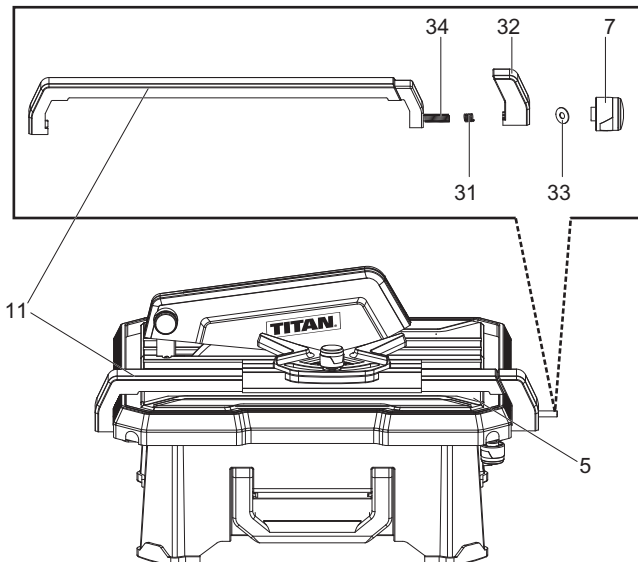

Fig. 9

Adjusting the parallel cutting guide

- > Gently release the locking knob (7).
- > Push the parallel cutting guide (11) to the desired distance.
- > Tighten the locking knob (7).

Mounting/setting the mitre cutting guide



NOTE: The mitre cutting guide can be set to a desired angle (0° ~ 45°). The mitre cutting guide can only be used when the parallel cutting guide is mounted.

- > Place mitre cutting guide (10) on parallel cutting guide (11).
- > Loosen locking knob (12).
- > Set mitre cutting guide (10) at desired angle.
- > Tighten locking knob (12).

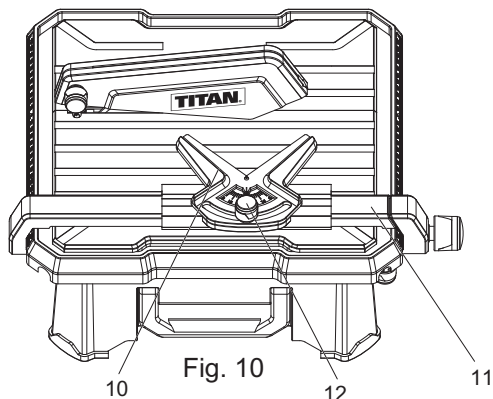

Setting product for jolly cuts



NOTE: The 45° vertical fence can be set to a desired angle (0° , 15° , 30° or 45°).

- > Raise the 45° vertical fence (3) approx. 45° .
- > Fold out the holder (35) and set to the desired angle in the locators (36).
- > Ensure that the 45° vertical fence (3) is correctly secured before working.

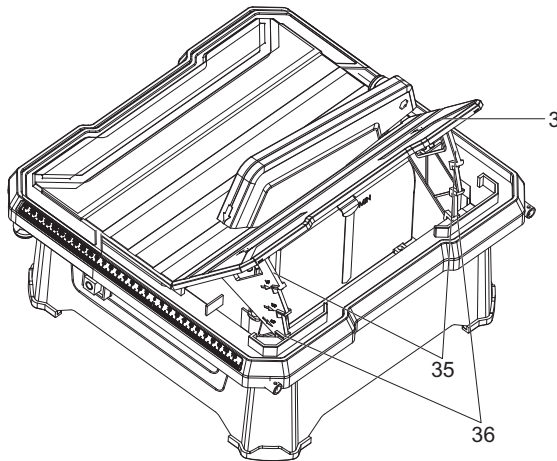

Fig. 11

Filling the product with water



NOTE: Product damage!

Fill the product with water only until water can drain from the opening in the plug.

During use the water level must never drop below the MIN marking.



NOTE: Product damage!

Fill the product only with clear water. Never use chemicals or cleaning agents. This can cause irreparable damage to the product.

Drain cooling water out of the product on completion of the work (Refer to "Replacing the cooling water" section).

- > Unplug the tile cutter from the mains supply.
- > Raise the 45° vertical fence (3) approx. 45° and remove.
- > Insert the water reservoir plug (16) into the drain opening.
- > Fill the tank with water only until water can drain from the opening in the plug.
- > Ensure that water just cover the disc edge (no more than ¼ of the disc is submerged in water).
- > When you have finished cutting, remove the water reservoir plug (16) inside the tank to drain the water.

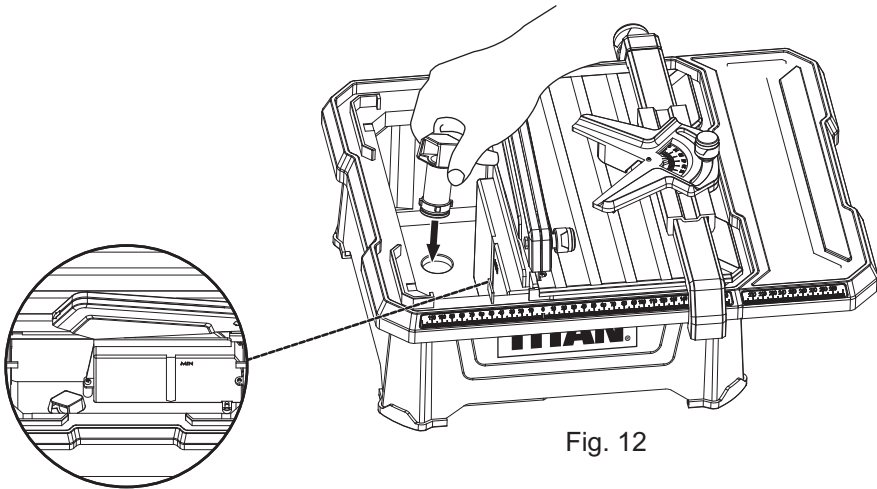

Fig. 12

Check before starting!



Warning: Risk of injury!

The product must be mounted in a stable position, i.e. on a workbench, a universal subframe or similar.



Warning: Risk of injury!

As soon as a malfunction occurs, push the red 0-Button on the On/Off Switch and pull out the mains plug.



Warning: Risk of injury!

The defect may be put into operation only if no defects or errors are found. Ensure that any defective parts are replaced before the product is used again.

Check the safe condition of the product before plugging the power cable:

- > Check whether there are any visible defects or faults.
- > Check whether all parts of the product are firmly attached.
- > Check that the safety devices are in faultless condition.
- > Check that the cutting disc can run freely.
- > Check there is sufficient cooling water in the product.

Connection to the electrical supply

- > Before switching on, make sure that the voltage of the mains supply is the same as indicated on the rating plate. This product is designed to operate on 230-240V~50Hz. Connecting it to any other power source may cause damage.
- > This appliance must be earthed. If in doubt, please consult a qualified electrician. The mains supply shall be fed via a 10A fuse min.
- > This machine must be supplied through a residual current device (RCD).



In more detail...

Product functions	23
Care and maintenance	27
Trouble shooting	33
Recycling and disposal	34
EC declaration of conformity	35



WARNING! Before switching the tile cutter on, make sure that you have read and understood all of the safety instructions. Make sure also that the machine has been correctly assembled and adjusted. Make sure that the mains is disconnected from the supply when the tile cutter is not being used, or adjustments are being made.



WARNING! Risk of injury!
Maintain an adequate distance from the cutting disc when cutting.



WARNING! Risk of injury!
Do not reach into the working range of the spinning cutting disc while the product is operating.



NOTE: Product damage!
Carefully check the workpiece to be machined. Foreign bodies such as nails, screws or similar can seriously damage the product.



NOTE: Product damage!
The product is not suitable for cutting materials such as marble, fine stoneware and granite. Tile floor made up of these materials must not be cut.



NOTE: Product damage!
Wait until the cutting disc has reached its maximum speed before commencing work.



NOTE: Product damage!
Before commencing work, check there is sufficient cooling water in the product.



NOTE: In the case of complex cuts (mitre or jolly) we recommend making a test cut beforehand.



WARNING! This machine must be supplied through a residual current device (RCD).



WARNING: The disc will continue to rotate for a few seconds after the machine has been switched off. Wait for the disc to stop before removing the workpiece, or making any adjustments.

Stop the machine immediately if there is undue vibration or some other fault. If this situation continues, check the machine to find the origin of the fault.

This tile cutter shall be used only to cut tiles to a required size or shape. It shall not be used to cut inflammable, explosive or toxic materials.

Other uses for the machine will lead to the damage of the machine and a series of dangers to the operator. This appliance is for private and household use, not for professional or industrial ones. Only identical accessories as the ones provided with the tile cutter are authorised. Never use the appliance in the rain or other wet conditions.

On/Off Switch



WARNING: Risk of injury!

Always pull out the mains plug in case of power failure (disconnect the product from its power supply). The product will start-up automatically as soon as power is restored.

Switching on:

- > The product can be switched on by pressing the green I-Button on the On/Off Switch (6).
- > Wait until the cutting disc has reached its maximum speed before commencing work.

Switching off:

- > The product can be switched off by pressing the red 0-Button on the On/Off Switch (6).

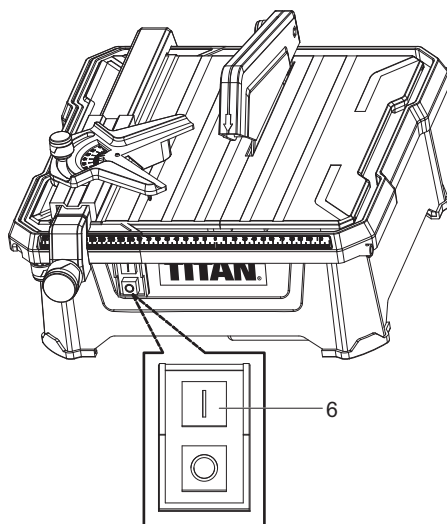

Fig. 13

Making a straight cut

Adjust the parallel cutting guide (11) to the desired width. Use the locking knob to loosen or adjust the guide. Position the tile firmly against the parallel cutting guide (11) and pass through the cutting disc in a smooth action. Hold the edges of the tile and press down firmly to prevent the tile lifting during the cut.

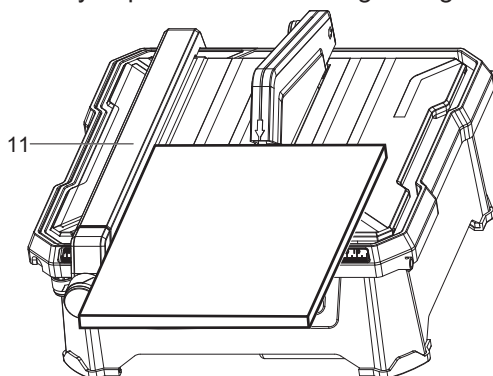

Fig. 14

Making a mitre or diagonal cut

Follow the same procedure for a straight cut but use the mitre cutting guide (10) in conjunction with the parallel cutting guide (11). The mitre cutting guide (10) simply clips onto the parallel cutting guide (11). Make sure that the tile is held firmly in the guide before making the cut.

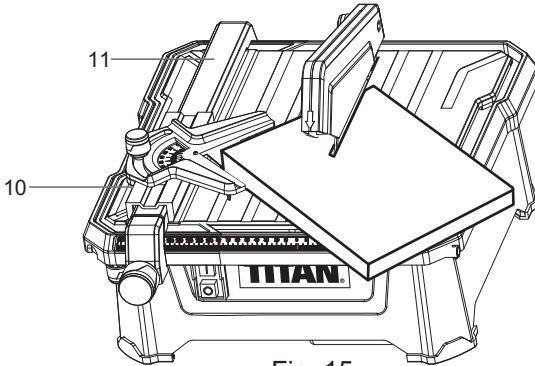

Fig. 15

Cutting an angle or bevel

Use the 45° vertical fence (3) if you wish to cut an angle or bevel on the tile edge. Raise the 45° vertical fence (3) approx. 45°. Fold out the holder and set to the desired angle in the locators. Then make the cut as before. Internal or external bevel cuts can be made by turning the tile face up or down (internal – eg. wall corner; external – eg. window reveal).

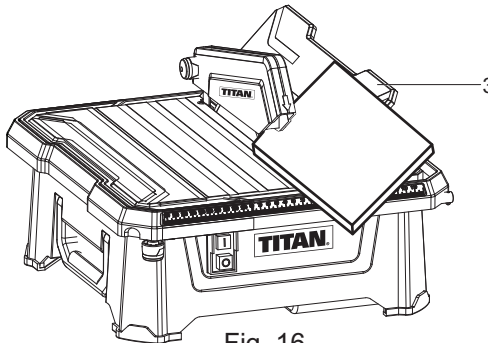

Fig. 16

The golden rules for care



WARNING! Always switch the product off, disconnect it from the power supply and let the product cool down before performing inspection, maintenance and cleaning work!

- > Keep the product clean. Remove debris from it after each use and before storage.
- > Regular and proper cleaning will help ensure safe use and prolong the life of the product.
- > Inspect the product before each use for worn and damaged parts. Do not operate it if you find broken and worn parts.



WARNING! Only perform repairs and maintenance work according to these instructions! All further works must be performed by a qualified specialist!

General cleaning



DANGER: Risk of electric shock!

Never spray the product with water or expose it to water. Never use detergents or solvents for cleaning. This can cause irreparable damage to the product. The plastic parts can be eaten away by chemicals.

Careful handling and regular cleaning ensure that the product remains functional and efficient for a long time.

- > Remove any dirt using a brush.
- > Wipe down the product with a slightly damp cloth.
- > Keep ventilation slots clean and free of dust.

Replacing the cooling water



DANGER: Risk of injury!

Dirt deposits can have sharp edges. Use clear water to remove dirt deposits.

- > Raise the 45° vertical fence (3) approx. 45° and remove.
- > Place a suitable collector below the product's drain opening.
- > Remove water reservoir plug (16) and drain off all the dirty cooling water.
- > Filling the product with water (Refer to "Filling the product with water" section on Page. 19-20).

Replacing the cutting disc



WARNING: Risk of injury!

Never use segmented cutting discs.



WARNING: Risk of injury!

Always wear protective gloves when replacing the cutting disc.



WARNING: Risk of injury!

The metal bracket must always be aligned parallel to the cutting disc.

Removing the cutting disc:

- > Raise the vertical fence (3) approx. 45° and remove.

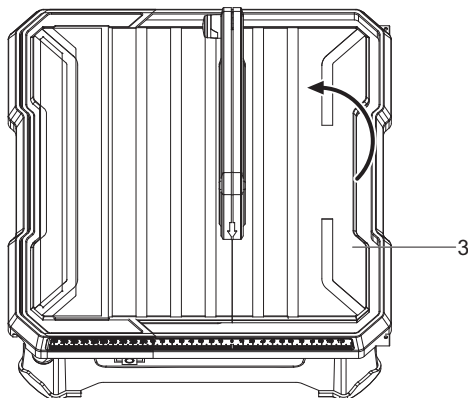

Fig. 17

- > Loosen cross-screws (19) and pull off lower protective guard (17).

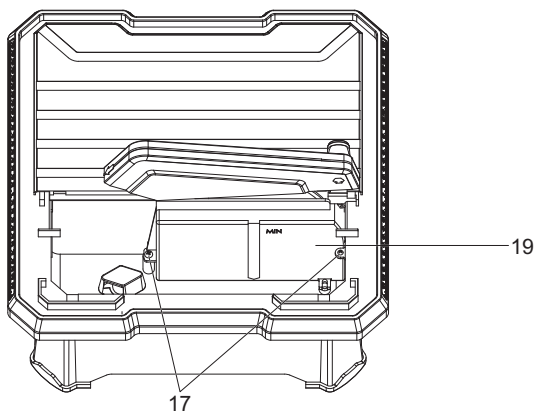

Fig. 17

- > Attach the straight spanner (20) to the hexagon nut (21).
- > Lock motor shaft (25) to prevent turning using angle spanner (23).
- > Loosen hexagon nut anti-clockwise using straight spanner (20).
- > Remove the hexagon nut and outer flange (22).
- > Remove the cutting disc (2) from inner flange.
- > Thoroughly clean outer flange, inner flange and motor shaft.

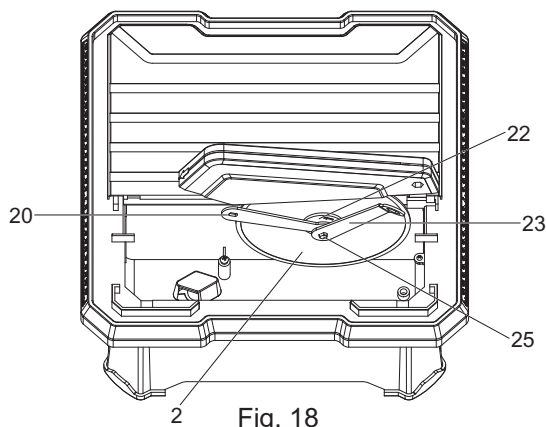

Fig. 18

Fitting the cutting disc: (Refer to "Fitting the cutting disc" section on Page. 11-13)

Power cord

> If the power cord is damaged, it must be replaced by the manufacturer, its service agent or similarly qualified person in order to avoid a safety hazard.

Plug replacement

If you need to replace the fitted plug then follow the instructions below.

Important

The wires in the mains lead are coloured in accordance with the following code:

Green & yellow - Earth

Blue - Neutral

Brown - Live

As the colours of the wires in the mains lead of this appliance may not correspond with the coloured markings identifying the terminals in your plug, proceed as follows. The wire which is coloured **green & yellow** must be connected to the terminal which is marked with **E** or \perp .

The wire which is coloured **blue** must be connected to the terminal which is marked with **N**. The wire, which is coloured brown, must be connected to the terminal, which is marked with the letter **L**.

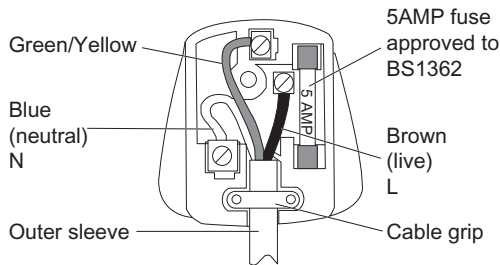

Fig. 47



Warning: Never connect live or neutral wires to the earth terminal of the plug. Only fit an approved 5 Amp BS1363/A plug and the correct rated fuse.



NOTE: If a moulded plug is fitted and has to be removed take great care in disposing of the plug and severed cable, it must be destroyed to prevent engaging into a socket.
If the supply cord is damaged it must be replaced by a service agent or a similarly qualified person in order to avoid hazard.

Repair

- > This product does not contain any parts that can be repaired by the consumer. Contact a qualified specialist to have it checked and repaired.
- > Apart from diamond discs there are no other user serviceable parts inside this tile cutter. Refer to qualified service personnel if internal maintenance is required. Any worn, or damaged parts should be replaced immediately by qualified personnel. Keep discs in good condition. Poor condition or worn discs can increase the noise level emitted.
- > If the supply cable is damaged, it should be replaced by the same type of cable as the one provided and recommended by the manufacturer (H05 VV-F 3G0.75 mm²). The supply cord of the tool and any extension cord used should be checked frequently for damage.
- > If damaged, have the cordset replaced by an authorised service facility. Replace the extension cord if necessary.

Storage



Warning: Risk of injury!

Store the product so that it cannot be switched on by unauthorized persons.
Ensure that nobody can injure themselves on the product while it is stationary.



NOTE: Product damage!

Do not store the product unprotected in a humid environment.

- > Store the product and its accessories in a dry, frost-free place.
- > Always store the product in a place that is inaccessible to children. The ideal storage temperature is between 10 and 30°C.

- > We recommend using the original package for storage or covering the product with a suitable cloth to protect it against dust.

Transport

- > Dismantle any components that protrude from the product.
- > Use the original packaging to ship whenever possible.
- > Protect the product from any heavy impact or strong vibrations which may occur during transportation in vehicles.
- > Secure the product to prevent it from slipping or falling over.

Trouble shooting

Suspected malfunctions are often due to causes that the users can fix themselves. Therefore check the product using this section. In most cases the problem can be solved quickly.



WARNING! Only perform the steps described within these instructions! All further inspection, maintenance and repair work must be performed by an authorised service centre or a similarly qualified specialist if you cannot solve the problem yourself!

Problem	Possible cause	Solution
1. Motor not running	1. No mains voltage.	1. Check cable, plug, socket and fuse.
2. Motor runs, cutting disc remains still when subject to load.	2. Flange nut loose.	2. Check the flange is seated correctly and tighten if necessary.
3. Cutting disc runs irregularly/vibrates	3.1 Cutting disc warped. 3.2 Cutting disc fitted incorrectly.	3.1 Replacing the cutting disc. 3.2 Fit the cutting disc correctly.
3. Cutting disc is discoloured.	4.1 Insufficient cooling water. 4.2 Lateral friction caused by cut runoff.	4.1 Fill the product with water. 4.2 Guide workpiece through cutting disc more slowly.

Recycling and disposal



- > Waste electrical products should not be disposed of with household waste. Please recycle where facilities exist. Check with your Local Authority or local store for recycling advice.

In more detail...

TITAN®

Declaration of Conformity

We, Importer
Titan Power Tools (UK) Ltd
Trade House, Mead Avenue, BA22 8RT

Declare that the product:
Designation: 650W tile cutter
Model: TTB597TCB

Complies with the following Directives:
2004/108/EC Electromagnetic Compatibility Directive
2006/42/EC Machinery Directive
2006/95/EC Low Voltage Directive
2011/65/EU Restrictions of the Use of Certain Hazardous Substances in Electrical and Electronic Equipment
2002/96/EC and 2003/108/EC Waste Electrical and Electronic Equipment (WEEE)

Standards and technical specifications referred to:

EN61029-1:2009+A11:2010
EN55014-1/A2:2011
EN55014-2/A2:2008
EN61000-3-2/A2:2009
EN61000-3-3:2008

Authorised Signatory and technical file holder
Date : 10/01/2014

Signature: P.C. Harries

Name / title: Peter Harries / Quality Manager
Titan Power Tools (UK) Ltd. Trade House, Mead Avenue, BA22 8RT



650W TILE CUTTER

TTB597TCB



Titan Power Tools (UK) Ltd
Trade House, Mead Avenue,
BA22 8RT
