

EMERGENCY

LED IP65 MAINTAINED BULKHEAD

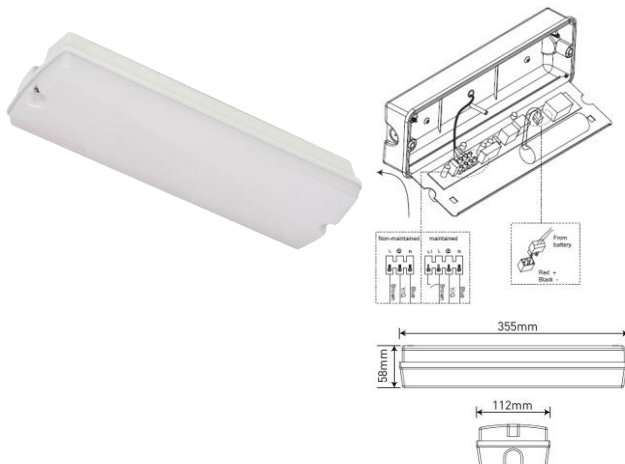

R8MLED-01

Power Consumption (W):	2.6
Batteries (NiCad):	3.6v 1.5Ah
Discharge duration:	>3hrs after 24 hr charge
Light output in emergency (lm):	60
Ambient Temperature Range (°C):	0 ≤ Ta ≤ +25
IP Rating:	65
Guarantee (Yrs):	2
Box Qty:	6
Weight (Kg):	0.57

These LED emergency bulkheads are aesthetically pleasing whilst making huge savings in electricity running costs and maintenance compared to traditional fluorescents.

They also provide some great installer benefits making installation fast and simple. For all building types these IP65 fittings can be wired for maintained or non-maintained operation, have a manual test switch version, and are suitable for surface mounting on walls or ceilings in:

- Offices
- Public buildings
- Shops and stores
- Health Centres
- Hospitals
- Schools
- Hotels
- Bars & Restaurants
- Entertainment Venues
- Workshops

FEATURES	BENEFITS
<ul style="list-style-type: none"> • Compact bulkhead only 58mm deep 	<ul style="list-style-type: none"> • Unobtrusive and looks neat
<ul style="list-style-type: none"> • ABS body, gear tray and PC opal diffuser with retained fixing screws 	<ul style="list-style-type: none"> • Strong, light, durable and resistant to damage • Provides bright light with low glare • Screws don't drop out and get lost when installing fitting
<ul style="list-style-type: none"> • 16mm/PG9 gland entry cut-outs on ends, top & rear 	<ul style="list-style-type: none"> • Suitable for conduit and most other wiring installation types
<ul style="list-style-type: none"> • Poured rubber diffuser to body seal 	<ul style="list-style-type: none"> • Provides IP65 rating so can be installed in/outdoors or in other wet areas
<ul style="list-style-type: none"> • Sprung hinged gear tray with press release catches 	<ul style="list-style-type: none"> • No tools required for quick and easy access for termination and mounting • Gear tray is supported so both hands can be used for installation
<ul style="list-style-type: none"> • Utilises high quality long life surface mount LED technology which: <ul style="list-style-type: none"> • Produces excellent light output • Only uses ≈ 2.6 watts of power • Provides an average LED life of 30,000 hours 	<ul style="list-style-type: none"> • Compared to T8 fluorescent: <ul style="list-style-type: none"> • Provides comparable light output so is a one for one replacement • Makes energy savings of over 65% • No maintenance cost for replacement tubes
<ul style="list-style-type: none"> • Spring Fast Fix incoming terminals suitable for 2 conductors per terminal. Includes removable link for "permanently on" operation 	<ul style="list-style-type: none"> • Allows fast loop in/out termination • Continuous spring force alleviates loose connections & ensures no hotspots • Links do not need to be made & inserted on site
<ul style="list-style-type: none"> • C/w NiCad rechargeable battery pack with green "charging" status LED 	<ul style="list-style-type: none"> • Provides 3 hour emergency operation • Provides up to 4 years backup under normal use • Indicates when mains power is charging the unit
<ul style="list-style-type: none"> • Mounting point centres moulded into base 	<ul style="list-style-type: none"> • Allows accurate, fast and simple installation