

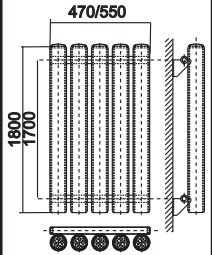





# Assembly Instructions

## Tube-in-Tube-radiator (SSU)

### Parts Supplied

Ref	Description	Illustration	Qty
A	Radiator		1
B	Air vent		1
C	Blanking plug		1

### Fittings Supplied

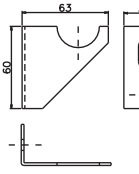
Ref	Description	Illustration	Qty
D	Masonry plug		4
E	Screw		4
F	Bolster		4
G	Bracket		4

### Tools Required (not supplied)

Drilling Machine Electric Drill Drill 10 mm Masonry Drill Bit 22 mm Spanner Screwdriver Hammer
--

### Before You Start

- Please read instructions carefully before installation.
- Check the pack and make sure you have all parts listed above. If not, contact your supplier who will be able to help you
- Ensure you have suitable isolation valves.
- Before drilling, first check that there are **no** hidden water pipes or electrical cables.
- This radiator is designed for use in closed heating systems only with a maximum pressure of 10 bars ( most common domestic heating systems do not exceed 3 bars )
- When you are ready to start, make sure you have the right tool to hand, plenty of space and clean dry area for assembly.
- Make sure that you use the right type of wall fixing. The plugs supplied are for solid masonry walls only.

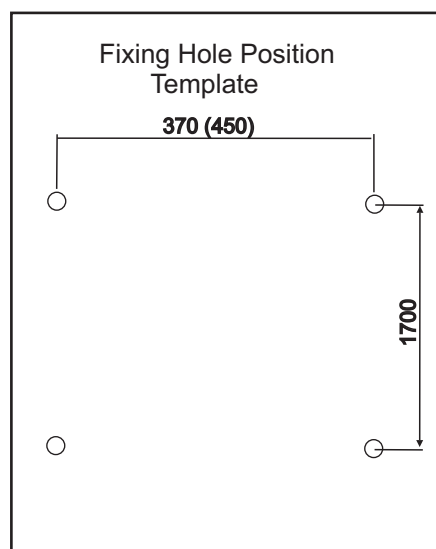

## Installation

1. Using the dimensions given in the fixing hole template if using the plugs supplied drill 4 holes to a depth of approximately 60 mm and a diameter of 10 mm.  
**NOTE:** The distance from the floor to the bottom of the radiator must be at least 200 mm for efficient heating and ventilation.  
The horizontal distance between the two ½" pipe connections is 470 (550)mm.
2. Insert masonry wall plugs ( D ) provided into the drilled holes, solid walls only.
3. Fasten screw ( E ) with bolster (F) through bracket ( G ) to fix securely to the wall.  
**Take care not to over tighten.**
4. Hang the radiator on the brackets.
5. Fit the supplied air vent ( B ) and blanking plug ( C ) into the upper threaded openings of the radiator.
6. Connect the water flow and the return pipe to the chosen side of the radiator and the isolation valves ( not supplied ). Ensure a water tight seal is obtained by using PTFE tape on the threads.
7. Open the valves of the radiator, fill and purge the remaining air from the radiator using the air vent ( B ). When full close the air vent.

## Care & Use

- After fitting you **MUST** be absolutely certain that the system is **THOROUGHLY** flushed before it is commissioned in order to rinse out any metal, flux and foreign residues. The system must also be thoroughly vented.
- To help prevent internal corrosion and lime scale formation a suitable inhibitor **MUST** be added to the central heating system when it is refilled
- Wipe radiator clean with a soft damp cloth. Never use scourers, abrasives or chemical cleaners.

## Troubleshooting

- If some pipes of the radiator are not warm, check and purge once more using the air vent.