

INSTALLATION & USER INSTRUCTIONS

HIGH EFFICIENCY GAS FIRE



Focal Point Fires plc.
Christchurch, Dorset BH23 2BT
Tel: 01202 499330
Fax: 01202 499326
www.focalpointfires.co.uk
e : sales@focalpointfires.co.uk

MODELS COVERED BY THESE INSTRUCTIONS

BLENHEIM HE GAS FIRE

HORIZON HE GAS FIRE

LULWORTH HE GAS FIRE

* AVAILABLE IN MANUAL OR FINGERSLIDE



MODEL SHOWN: BLENHEIM HE GAS FIRE

Questions or problems with your appliance?

Don't take it back to the store

Just give us a call on **01202 588601**
or email **3g@focalpointfires.co.uk**

We're here to help
Lines open between 9am and 5pm, Monday to Friday

3 YEAR GUARANTEE

SUBJECT TO TERMS & CONDITIONS

For details please see: www.focalpointfires.co.uk/tandcs or telephone
01202 588635 Option 7

The products covered by this booklet are protected under patent GB2356698B

IN THE UK ALWAYS USE A GAS SAFE REGISTERED ENGINEER TO INSTALL, REPAIR OR SERVICE THIS APPLIANCE



Please note : Except where otherwise stated, all rights, including copyright in the text, images and layout of this booklet is owned by Focal Point Fires plc. You are not permitted to copy or adapt any of the content without the prior written permission of Focal Point Fires plc.

**All instructions must be handed to the user
for safekeeping.**

Revision J - 02/16

Section	Contents	Page No.	Section	Contents	Page No.
1.0	Important Notes	2	8.4	Fitting the Burner	7
2.0	Appliance Data	3	9.0	Final Assembly, Testing and Commissioning	7
3.0	Installation Requirements	3	9.1	Spark Gap	7
4.0	Site Requirements	3	9.2	Fuel Bed Layout	7
4.1	Debris Collection Space	4	9.3	Final Assembly	8
5.0	Ventilation	5	9.4	Operating the Appliance - Manual control	8
6.0	Prefabricated Flue Boxes	5	9.5	Operating the Appliance - Slide control	9
7.0	Unpacking the Appliance	5	9.6	Setting Pressure	9
7.1	Component Checklist	5	9.7	Flue Spillage Monitoring System	9
8.0	Preparing the Appliance	6	9.8	Testing for Spillage	10
8.1	Preparing the Opening	6	10.0	Briefing the customer	10
8.2	Gas Supply	6	11.0	Servicing	10
8.3	Cable Fixing	7	12.0	Troubleshooting Guide	11
			12.0	Troubleshooting Guide (continued)	12

1.0 IMPORTANT NOTES

- This fire is an Inset Live Fuel Effect Gas Fire providing radiant warmth. It is designed to operate on Natural Gas only at the pressure stated on the appliance data plate.
- The appliance incorporates a combustion monitoring system (Oxygen Depletion System). It must not be adjusted or put out of operation. If replaced then manufacturer's original parts must be used.
- It is the LAW that all gas appliances and fittings are installed by a GAS SAFE registered person and in accordance with the Gas Safety (Installation and Use) Regulations 1998, the relevant British Standards for Installation, Codes of Practice and in accordance with the Manufacturers' Instructions.
- In the event of gas leakage from the appliance, the gas supply must be turned off at the nearest isolating valve.
- The appliance must be installed in accordance with the following:
 - Manufacturers' Instructions.
 - The Building Regulations issued by the Department for Communities and Local Government, the Building Standards (Scotland) (Consolidation) Regulations issued by the Scottish Development Department.
 - Relevant British standards :
 - BS 5871 part 2
 - BS 5440 part 1, part 2
 - BS 1251
 - BS 6891
 - BS 6461 part 1
 - BS EN 1806
 - BS EN 1856 part 1
 - BS EN 1858
 - For Republic of Ireland, reference should be made to the relevant standards governing installation, particularly in regard to flue sizing and ventilation. See IS813, ICP3, IS327 and any other relevant rules in force.
- Failure to comply with the above could lead to prosecution and deem the manufacturer's warranty invalid.
- This appliance must be installed in accordance with the rules in force and used only in a sufficiently ventilated space. The appliance is designed to fit various types of situations as described in sections 3.0 and 4.0.
- It should be noted that heaters create warm air currents. These currents move heat to surfaces next to the heater. Operating the heater where impurities in the air (such as tobacco smoke, candle smoke etc.) exist, may cause surfaces to become discoloured.
- On first light up of a new appliance, burning off of high temperature paint and lubricants may occur for the first few hours of operation. During this period some smoke may be emitted, this should be no cause for concern. Accordingly, the room should be well ventilated with all windows and doors open during this period. During this period the appliance may cause smoke alarms to sound. If this happens, reset the alarms, but do not remove the batteries.
- **WARNING:** Due to the nature of this product the area around the top of the appliance (i.e. the hood) gets very hot. Care should be taken when operating the appliance. The manufacturer of this appliance considers all surfaces as working surfaces with the exception of the control knob. The guard (glass front) is to prevent risk of fire or injury from burns and no part of it should be permanently removed.
 - **As with any gas fire, a fire guard complying with BS 8423 must be used in presence of pets, children, and the elderly or infirm.**
- Consult ALL instructions before installation and use of this appliance.
- This appliance is free from any asbestos material.

2.0 APPLIANCE DATA

GB IE

Control Type	Destination Countries	Cat	Inlet/Operating Pressure (± 2.0 mbar)				Max Energy Input (kW)		Min Energy Input (kW)	
			G20	G25	G30	G31	Gross	Net	Gross	Net
Manual	GB/IE	I2H	20	-	-	-	5.0	4.5	3.5	3.15
Slide	GB/IE	I2H	20	-	-	-	5.0	4.5	3.5	3.15

Specifications	Manual Control Models	Slide Control Models
Efficiency	90% (net), 81% (gross)	90% (net), 81% (gross)
NOx Class	2	2
Pilot Energy Input	166W (gross)	166W (gross)
Main burner injector	Stereo size 65	Stereo size 66
Oxypilot	SIT 9082/ SIT 9081/ Copreci 21100 2F/ 297	SIT 9082/ SIT 9081/ Copreci 21100 2F/ 297
Gas Control	Copreci 21400 Series	Teddington TESA 3173/011
Gas Inlet	All models - 8mm compression - Inlet restrictor elbow	
Ignition	Double-action piezo Spark	Battery Spark
Spark Gap	3.5 - 4.5mm	3.5 - 4.5mm
Weight	20Kg	20.5Kg
Flue specification	All models - 225mm x 225mm (9in x 9in) brick or stone. 125mm (5in) minimum diameter lined brick or stone. 125mm (5in) minimum diameter twin wall flue conforming to BS 715. Pre-cast block flue complying with BS 1289 or BS EN 1858.	

The efficiency of this appliance has been measured as specified in BS 7977-1:2002 and the result is 81%. The gross calorific value of the fuel has been used for this efficiency calculation. The test data from which it has been calculated has been certified by GL Industrial Services (0087). The efficiency value may be used in the UK Government's Standard Assessment Procedure (SAP) for energy rating of dwellings.

3.0 INSTALLATION REQUIREMENTS

This appliance **MUST NOT** be installed into a room containing a bath or shower, or where steam may be present. The fire has been designed to fit into a builders' opening or fireplace conforming to BS 1251 or BS EN 1858 (and meeting certain dimensional requirements), or a suitable flue box complying with the constructional requirements of BS 715. The flue box must be installed onto a suitable non-combustible insulating surface at least 12mm thick, covering the entire base area of the box.

A natural draught flue system is required, and if previously used for solid fuel or oil burning, the flue and chimney must be swept prior to appliance installation. The flue must be checked before installation by using a smoke pellet or similar to ensure proper draw and that leakage is not evident at any joints. Repair and re-test as necessary before the appliance is installed. The flue must have an effective height of at least three metres, as measured from the hearth to the top of the flue. Any flue damper plates or restrictors should be removed and no other restriction fitted to the flue. Where removal is not practical, the restriction must be fixed in the fully open position. The flue must be connected to only one fireplace, and the flue must not vent more than one appliance (i.e. not shared with a gas back boiler). There must be no opening in the flue apart from the one that the appliance is installed into, and the one venting the gases into the air. A suitable terminal may be fitted, such as class GCI, as regulations allow.

This appliance has been tested for use in a pre-cast block flue complying with BS 1289 or BS EN 1858. In accordance with BS 1289 part 1, pre-cast flues built with directly plastered faces (front or rear) are not correctly installed as to ensure proper operation with **any** type of gas fire. In some instances of this flue construction, temperature cracking of the surface plaster may occur through no fault of the appliance. An air gap or some form of insulation material should be installed to prevent normal flue temperatures from damaging wall surfaces. Pre-cast flues must be checked for mortar fangs and correct installation of joints, flue sections in loft space and terminals.

This appliance has been tested for use with circular flues of a minimum internal diameter of 125mm.

This appliance MUST be installed into a non combustible back panel capable of withstanding 150°C.

4.0 SITE REQUIREMENTS

The fireplace opening should be inspected and repairs made where necessary. Any chair brick or fireback may be left in situ, providing that the dimensional requirements for debris collection space and spigot clearances are met. See figure 1. The opening **WIDTH** and **HEIGHT** dimensions should be between 400mm and 440mm wide, and 550mm to 575mm high.

Opening **DEPTH** should be 145mm or greater for a clay/cement lined or pre-cast flue which is new, unused or previously only used with a gas fire. **DEPTH** should be 185mm or greater for a flue which has previously been used for a solid fuel or oil burning appliance. Opening **DEPTH**s include any plaster or infill panels which form part of the installation. Any existing under grate draught device must be sealed off. **WARNING** This fire is designed to get very hot! The fireplace opening wall or back panel must be non-combustible and rated to withstand 150°C.

4.0 SITE REQUIREMENTS (continued)

This appliance requires a natural draught flue system which may be one of the following;

- 225mm x 225mm (9in x 9in) brick or stone.
- 125mm (5in) minimum diameter lined brick or stone.
- 125mm (5in) minimum diameter twin wall flue conforming to BS 715.
- Pre-cast block flue complying with BS 1289 or BS EN 1858.

The appliance requires a hearth with non-combustible surface of at least 12mm thick. The top surface must be at least 50mm above the surrounding floor level, or be surrounded by a raised edge or fender 50mm high.

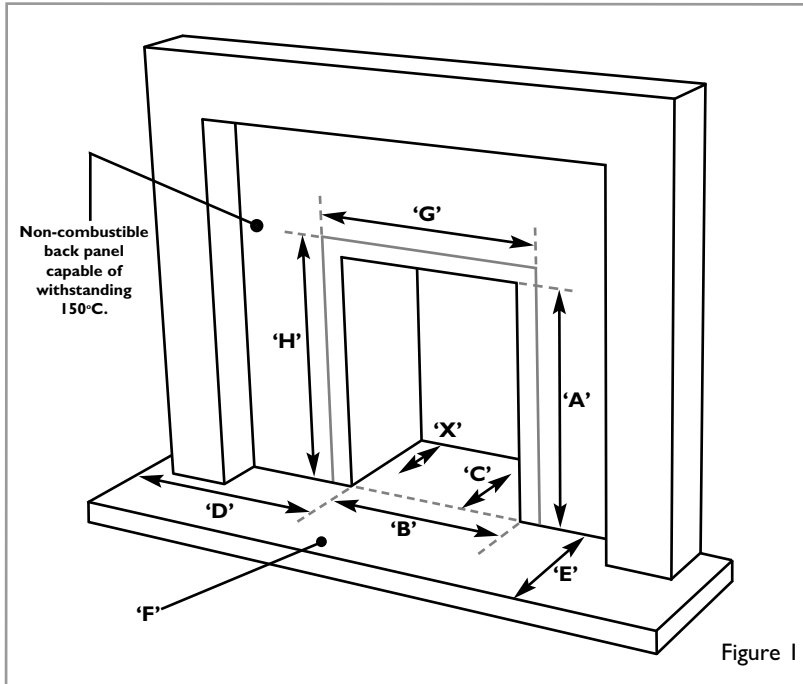

- A.** Opening height: 550mm min/575mm max.
- B.** Opening width: 400mm min/440mm max.
- C.** Mounting depth: 125mm
- D.** Hearth must extend minimum of 150mm either side of the opening.
- E.** Hearth must extend minimum of 300mm in front of the fuelbed.
- F.** Non-combustible hearth must be a minimum of 50mm in height, or be surrounded by 50mm high fender.
- G.** 470mm: This area must be flat and vertical to allow good frame sealing.
- H.** 585mm: This area must be flat and vertical to allow good frame sealing.
- X.** See section 4.1.

To enable the products of combustion to be cleared properly up the flue, the outlet at the back of the appliance must have a 50mm minimum clearance between it and the back wall of the opening or any other obstruction. The area immediately above the outlet must form a smooth path into the flue.

Any type of fire surround used with this appliance must be adequately sealed to the wall and floor.

A combustible shelf may be fixed to the wall above the fire, providing that it complies with the dimensions given below.

Maximum depth of shelf	Minimum distance from finished hearth surface to underside of shelf
100mm (4in)	745mm (29 ¹ / ₄ in)
150mm (6in)	845mm (33 ¹ / ₄ in)
203mm (8in)	895mm (35 ¹ / ₄ in)

A non-combustible shelf may be fitted to within 10mm of the top edge of the fireframe. Combustible materials, such as wood, may be fitted to within 100mm (4in) of either side of the fireplace opening, providing the forward projection does not exceed 100mm (4in). Any combustible side walls must be at least 500mm to the side of the radiant heat source. As with all heating appliances, any decorations, soft furnishings, and wall coverings (i.e. flock, blown vinyl and embossed paper) positioned too close to the appliance may discolour or scorch.

4.1 DEBRIS COLLECTION SPACE

The mounting depth of this appliance is 125mm. In accordance with BS 5871 part 2, minimum debris collection volumes are required behind the installed appliance. These are as follows and shown as dimension X in figure 1.

CLAY/CEMENT LINES OR BLOCK FLUE WHICH IS NEW, UNUSED, OR PREVIOUSLY ONLY USED WITH A GAS FIRE
X Dimension = 20mm

UNLINED FLUE OR CHIMNEY WHICH HAS BEEN PREVIOUSLY USED FOR A SOLID FUEL OR OIL BURNING APPLIANCE
X Dimension = 60mm

No purpose provided ventilation is normally required for this appliance. The requirements of other appliances operating in the same room or space must be taken into consideration when assessing ventilation.

If spillage is detected when commissioning the appliance, then amongst other problems there may be insufficient natural ventilation for correct operation of the flue. If the appliance does not spill with the windows open, but spillage is detected with the windows closed, this demonstrates a lack of natural ventilation. If spillage is still detected with the windows open, the flue is at fault. Installation of an air brick is the best solution to lack of ventilation. Any ventilation fitted must comply with BS 5871 part 2 and BS 5440 part 2. Vents fitted under or within the immediate vicinity (1 metre) of the appliance must not be used as adverse effects to the operation of the ODS may occur. Spillage detected during commissioning is almost always a result of poor flue performance that cannot be corrected by any amount of ventilation.

For Republic of Ireland ventilation may be required, see IS 813, ICP3, IS 327, and any other rules in force.

This appliance can be fitted into a number of proprietary flue boxes provided that the minimum dimensions given in figure 2 are complied with.

6.0 PREFABRICATED FLUE BOXES

Constructional Note: The frame of the fire, any back panel or other infill panels, and the flue box must be sealed together so that there is no possibility of leakage between them. Adequate clearances to combustible materials (e.g. false chimney breast construction) must be maintained.

The manufacturers' instructions for fitting the prefabricated box shall be complied with at all times. To fit the fire using the cable fixing kit, some minor adaption may be necessary for certain flue boxes. A check should be made to ensure the firebox does not obscure the flue box outlet. The firebox, base of the flue box, and hearth below may be drilled to allow plugs and screws to secure installation. It is important that the sealing requirements of the appliance are met at all times and that the flue box is well sealed to any back or infill panel. **Note:** The DEPTH dimension is inclusive of any back or infill panel.

Stand the carton the right way up, cut the strapping bands and remove the top endcap.

Figure 2

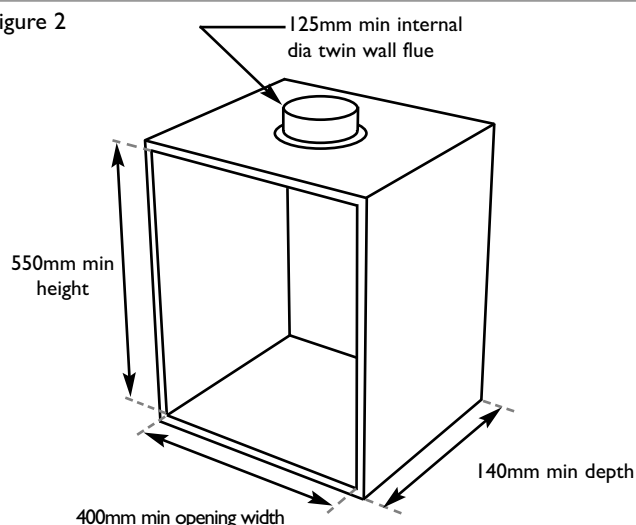

7.0 UNPACKING THE APPLIANCE

Read **all** the instructions before continuing to unpack or install this appliance. Remove the box containing the firefront, and the bags containing the ceramic components. Remove the cardboard packing pieces, and any other bags or boxes containing fittings or other parts. When all loose parts have been removed, the outer sleeve may be lifted off to reveal the appliance. Check that the components supplied correlate with the component checklist given in section 7.1. Please dispose of all the packaging materials at your local recycling centre.

7.1 COMPONENT CHECKLIST

QUANTITY	DESCRIPTION
1	Firebox and burner assembly
1	Decorative frame : three-piece frame or a one-piece frame (fingerslide models only)
1	Firefront
1	Black moulded ceramic fibre combustion matrix
4	Moulded ceramic coal pieces
1	Front ceramic decorative strip (dependent on model)
1	Ceramic rear panel
1	Cable fixing kit; 2 cables, 2 tensioners, 2 cable clamps, 4 fixing eyes
1	Sealing grommet
1	Screw pack : 7 x No8 x 5/16 Self tapping type, 2 x M4x12 Machine screw type
1	Spigot restrictor
1	Deflector baffle/burner heatshield (shown in fig.11)
1	Smoke match tube
1	Set of manufacturers instructions
4	Wall Plugs
1	Slide control models only : Slide control position marking sticker
1	Slide control models only : Slide control knob and M4 Nyloc nut

8.0 PREPARING THE APPLIANCE

GB IE

The fireplace opening and environment must be in compliance with specifications laid down in the appropriate sections of these instructions. Remove the appliance from its carton as described previously and stand upon a dust sheet or similar. Place the decorative frame, coals, ceramics and fixings safely to one side. Remove the glass panel assembly by removing the retaining screws. Remove the burner from the assembly by removing the retaining screws (slide control models only - disconnect the slide mechanism by removing one M4 nut from the assembly). The tray is now free, and may be lifted away.

Spigot restrictor : The appliance is supplied with an optional spigot restrictor.

The spigot restrictor may be fitted when the fire is to be installed in a good class I flue, a conventional brick chimney, or a 175mm (7") circular flue. The spigot restrictor is not recommended for pre-cast and 125mm (5") circular flues as it may cause spillage. If required, fit the spigot restrictor using three No8 x 5/16 Self tapping screws (supplied loose) as shown in figure 3.

If spillage is detected during the commissioning of the appliance, the spigot restrictor should be removed immediately.

Slide controls models : The control knob is supplied as a loose part. Insert the control knob into the hole in the top of the slide control spindle (Figure 4). Secure the control knob in position using the M4 nyloc nut provided. Affix the Slide control position marking sticker on the trim next to the control knob as shown in figure 16.

Supply pipe entry : Knockout holes are provided in the rear and sides of the firebox for use where concealed pipework is required. Where necessary, knock out the appropriate hole with a sharp tap from a hammer, and fit the rubber grommet supplied. A small incision can now be made in the rubber to slip snugly around the outside of the pipe and sleeving. **Do not install or use the appliance without the seal in place.** If a hole is inadvertently opened, reseal with an intact grommet. Failure to fit the seal correctly will cause flue suction to act upon the area under the burner, resulting in poor performance and intermittent cutting out of the burner. Some possible pipe routes are shown in figure 6.

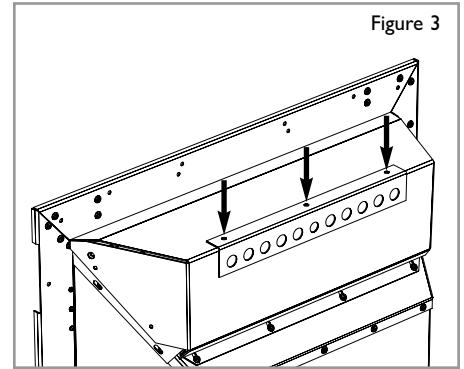

Figure 3

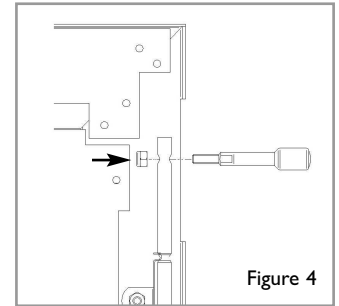

Figure 4

8.1 PREPARING THE OPENING

The appliance is supplied with a high temperature rope sealing strip factory fitted to the firebox.

Before installing the fire, check the flue for correct operation using a smoke pellet. All of the smoke should be drawn up the flue and exit correctly from the terminal. If problems are found **DO NOT** fit the fire until corrective action is completed.

Protect the decorative hearth whilst pushing the convector box in and out of the opening. Part of the packaging is an ideal hearth saver pad.

Before running the gas supply into the opening, offer up the convector box to the fireplace to check the fit is good. Ensure that it slides in correctly, the sealing face sits flat and square to the wall or infill panel, and that the base is firm in the floor of the opening as no leaks are permissible here. At this stage it is essential to ensure that the spigot outlet of the fire is not obstructed in any way. Remove the convector box and take any necessary measurements before making good and preparing for final installation.

Cable fixing : Drill four holes as shown in figure 5 and fit the wall plugs. If the fireplace does not allow for the exact layout shown, the eyebolts should be fixed to give a similar configuration as possible. To complete the cable fixing of the convector box, refer to section 8.3.

Fixing by screw : Mark and drill the fireframe or base, and relevant points in the opening or on the wall. Additional screws will be required for this method of fixing.

8.2 GAS SUPPLY

When the opening is ready for installation of the fire, the gas supply can be routed. Some possible supply pipe routes are shown in figure 6. Select the supply route most relevant to the entry point of the gas supply into the fireplace opening. The gas pipe must be suitably protected where it passes through fireplace openings. Any sleeving should be sealed to the pipe at its ends.

The open end of the gas supply pipe should be temporarily sealed to prevent ingress of dust and dirt during installation.

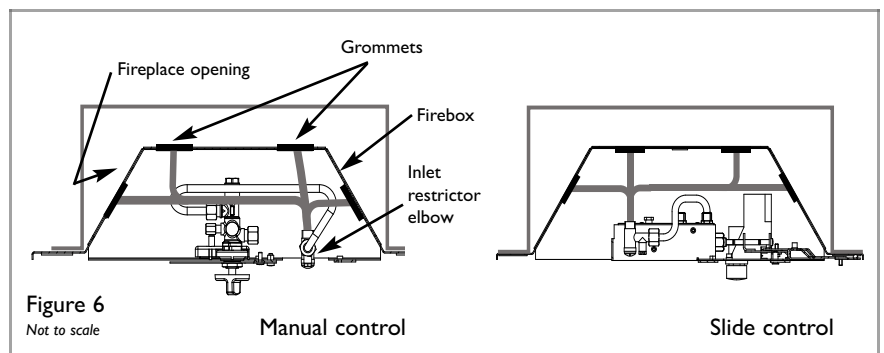

Figure 6
Not to scale

Manual control

Slide control

8.3 CABLE FIXING

GB IE

Thread both tensioning cables through the holes at the top of the firebox, both eyelets, and back through the lower holes in the firebox in the positions indicated in figure 7. Push the appliance back into the fireplace, centralise and pull the loose cables through the holes into the firebox.

Thread the cable tensioners onto the cables as shown, with the nuts screwed down close to the tensioner head. Slide the screwed nipple onto the cable, pull cable taut and tighten nipple. Adjust tensioner using suitable spanners to pull the appliance back into position, to allow an even seal around the fireplace opening. See figure 8. Visually inspect the seal and reseal if necessary.

Surplus tension cable **MUST NOT** be cut off as this will prevent proper installation after servicing. Coil up the surplus cable as shown in figure 9.

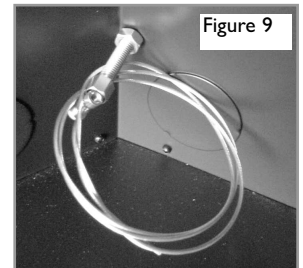
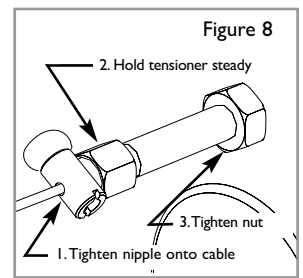
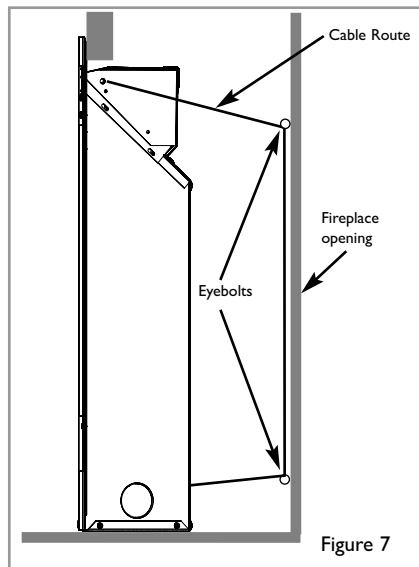

8.4 FITTING THE BURNER

Temporarily fit the burner tray and ensure a suitable gas route can be achieved. Place the burner tray into the firebox making sure that the rear lugs locate properly on to the ledge in the firebox.

Manual control models : Fit the two securing screws through the tray legs to secure the assembly.

Slide control models : Fit the four securing screws - **two through the tray rear first** and then two through the legs of the tray to secure the assembly - see figure 10. Reconnect the slide mechanism by replacing the M4 nut and serrated washer on the assembly.

All models : Connect the gas supply and tighten the gas connections. Fit the deflector baffle to the two locations on the front face of the firetray as shown in figure 11. Screws are provided for this purpose. The baffle should be level with the lower edge of the tray. Place contemporary firefront in front of the fire temporarily to check the angle of the baffle. The front should fit well and the control devices beneath should not be visible to the eye. Realign the baffle slightly if necessary to achieve the correct fit.

Purge the gas supply thoroughly to remove air and dirt/debris **BEFORE** connection. Now disconnect the inlet restrictor elbow from the inlet pipe.

Connect the previously installed gas supply to inlet restrictor elbow, and refit the restrictor elbow to the inlet pipe of the appliance.

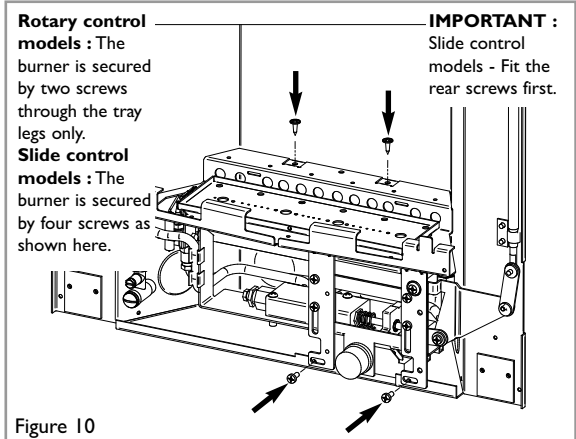

Figure 10

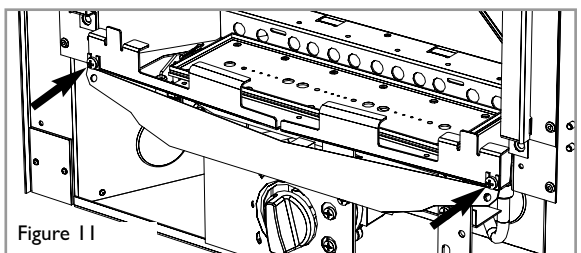

Figure 11

9.0 FINAL ASSEMBLY, TESTING AND COMMISSIONING

Turn on and test the gas supply up to the fire for any leaks, in accordance with current edition of BS6891.

When the appliance is first used, protective oils coating the firebox may burn off. It is advisable to ventilate the room during this period for at least one hour.

9.1 SPARK GAP

The spark gap between the spark electrode and the thermocouple should be 3.5 - 4.5mm to produce a good spark. There should be no need to adjust this.

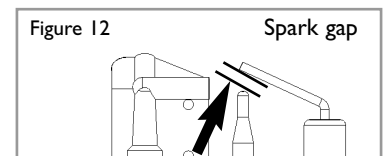

Figure 12

9.2 FUEL BED LAYOUT

For fuel bed layout instructions, refer to section 10.0 of the user instructions.

Glass Panel : Refit the glass panel ensuring that the unsealed edge of the glass is facing downwards. Take care not to damage the ceramic fuel bed when fitting. Secure using four M6 screws previously removed.

Hood : Now fit the hood. This is provided separately. Remove all protective packaging materials. Carefully attach using two No8 x 5/16 self tapping screws (also provided within loose parts) in the positions shown in figure 13. Do not overtighten.

Front coal piece (dependent on model) : Now fit the decorative front coal piece. This is intended to sit flush in front of the glass panel in order to complete the realistic coal fuel effect.

Attach the strip using two M4 screws in the positions shown in figure 14. Take care not to damage the ceramic part of the component.

The appliance is supplied either with a one piece or three piece decorative frame.

For one piece frames (fingerslide models only) : The appliance is supplied with a one piece decorative frame that is attached to the front of the firebox with the magnets provided.

Place the decorative firefront in front of the fire and slide the ashpan door into place. The firefront shown in these instructions may be different to the one supplied with the appliance.

For three piece frames : The side pieces of the clip on assembly should be pushed into position first, followed by the top bar (shown in figure 15), which should overlap the sides.

IMPORTANT NOTE: Due to the possibility of sharp edges, care should be taken when handling the three piece frame components. The use of protective gloves is recommended. Place the firefront

into position in front of the fire and slide the ashpan door into place. Do not use any other firefront other than the one supplied with this appliance. The firefront shown in these instructions may differ from the one supplied with the appliance.

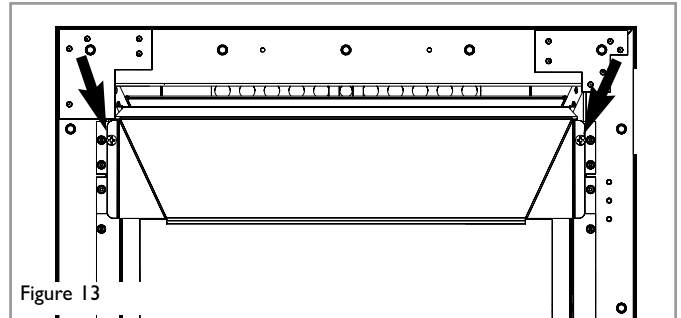

Figure 13

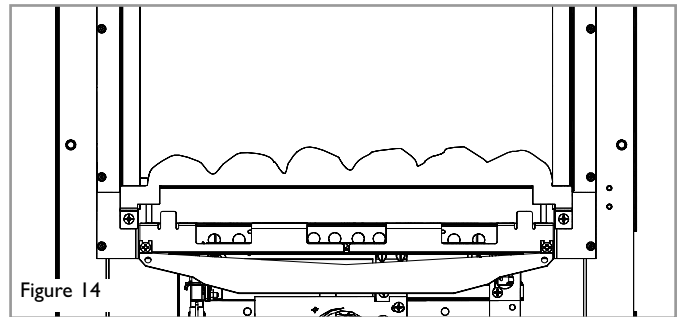

Figure 14

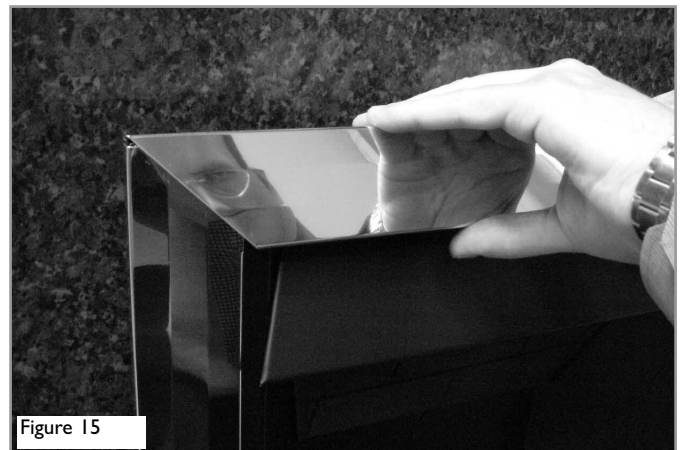

Figure 15

9.4 OPERATING THE APPLIANCE - MANUAL CONTROL MODELS

The pilot is visible through the viewing hole which is located at the lower left hand side of the fuel bed. The fire features a 'twin spark' ignition system to aid lighting. Push the control knob in fully and turn anti-clockwise through both of the SPARK positions, keeping fully depressed, hold there for a few seconds. If the fire has not been used for some time, hold the knob in this position for longer, to allow any air in the pipes to be purged. Continue turning anti-clockwise through the spark clicks to the nine o'clock position, ensuring the pilot has lit. If not, return the knob clockwise, and repeat.

When the pilot lights after one of the two sparks, keep the knob depressed in the nine o'clock position for approximately ten seconds. Now release the knob and the pilot should stay alight. If the pilot is extinguished during use, wait three minutes before repeating the ignition procedure. To achieve the HIGH setting, push the control knob in slightly and continue turning anti-clockwise to the high position. The main burner should light after a few seconds. To decrease the setting to LOW, push the knob in slightly and turn the control knob clockwise to the low setting. To turn to the pilot only position from the HIGH or LOW positions, press the control knob in, and return to the nine o'clock position and release. To turn the fire OFF, keep the knob pressed in, return to the off position and release.

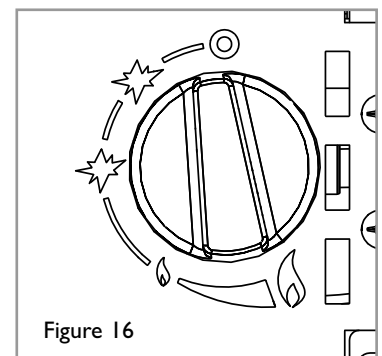

Figure 16

The pilot is visible through the viewing hole which is located at the lower left hand side of the fuel bed.

Push the slide control knob fully downwards to the SPARK position, and hold there for approximately ten seconds. Now release the knob and the pilot should stay alight. When the pilot light has established, move the slide control knob upwards to the LOW flame setting. If the pilot is extinguished during use, wait three minutes before repeating the ignition procedure. To achieve the HIGH setting, move the slide control knob upwards to the HIGH flame setting. The fire can also be set to operate anywhere between HIGH and LOW by moving the control knob to an intermediate position. To turn the fire OFF, move the slide control knob upwards fully to the position marked 'O'.

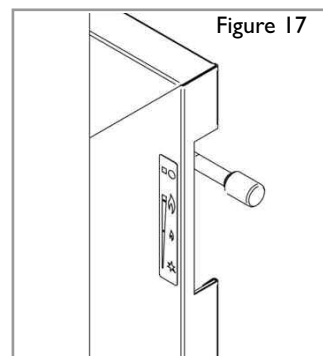

Figure 17

9.6 SETTING PRESSURE

Remove the screw from the pressure test point.

Release the pressure test point screw, and attach a pressure gauge. Light the fire on the HIGH setting. To commission the appliance, the operating pressure must be in accordance with the figures stated in section 2.0 of these instructions. The fire is factory set to achieve the correct flow rates at the specified operating pressure. Any significant variation in the operating pressure could indicate

a supply problem. If the operating pressure is too high, the gas supply meter/governor may be set incorrectly. This should be checked with the fire running and if necessary reset by the gas supplier. If the operating pressure is too low, then check the meter/governor pressure with the appliance running. If this is less than the inlet pressure stated in section 2.0 of these instructions it will need to be reset by the gas supplier. If the inlet pressure is too low, but the meter/governor pressure is acceptable, then a problem in the supply pipework is to be suspected. Upon satisfactory checking of the inlet pressure, turn the fire off, disconnect the pressure gauge and refit the test point screw. Light the fire and check for gas soundness. In the event that the inlet pressure is not in accordance with the figures stated in the data section of these instructions, the appliance must not be commissioned, and the problem investigated and rectified.

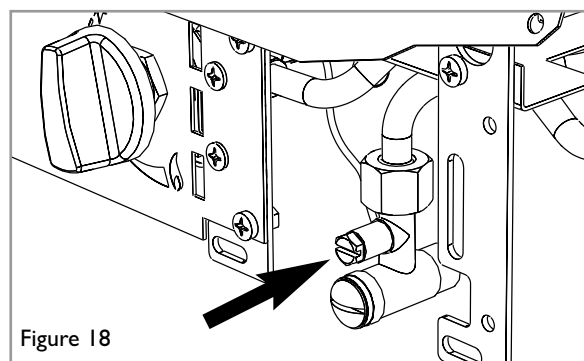

Figure 18

9.7 FLUE SPILLAGE MONITORING SYSTEM

This fire is fitted with a flue spillage safety device (ODS).

If the fire shuts down during use for no apparent reason then several things may be suspected. If a door or window has been opened creating a draught, then pilot disturbance is the problem, and removal of the draught should resolve this. Re-check the gas pressure to ensure it is adequate (see section 2.0). The thermocouple connection into the back of the gas control valve may also have worked loose during installation, in this case re-tighten.

If pilot disturbance is not the cause, then the ODS safety system may be in operation. Switch the appliance OFF, check the flue and carry out any remedial work required. Relight the fire and carry out a spillage test. DO NOT allow the appliance to be used if it continues to fail a spillage test.

The aeration hole of the pilot must be carefully cleaned out on each annual service to ensure continued function of the ODS. The spillage monitoring system shall not be adjusted, modified, or put out of operation by the installer. Any spare parts fitted MUST be of a type supplied for the purpose by the appliance manufacturer. If the fire is not spilling, then further guidance should be sought, using the Troubleshooting section as a guide.

Close all doors and windows to the room containing the appliance. Let the fire run on HIGH for five minutes. Take a smoke match and put in the smoke match tube provided. Light the smoke match and position the end of the smoke match tube centrally next to the draught diverter as shown in figures 19 and 20.

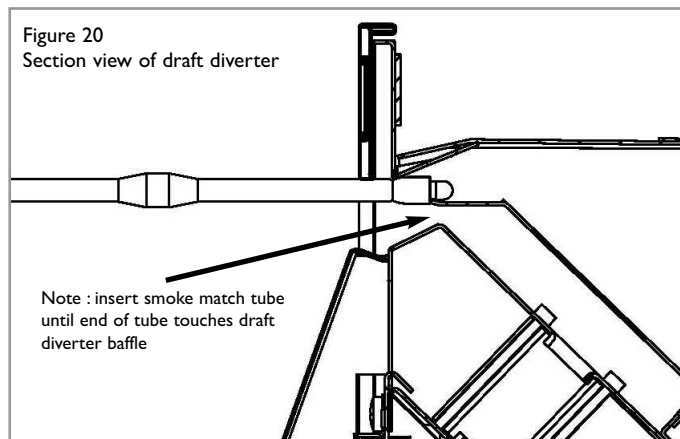
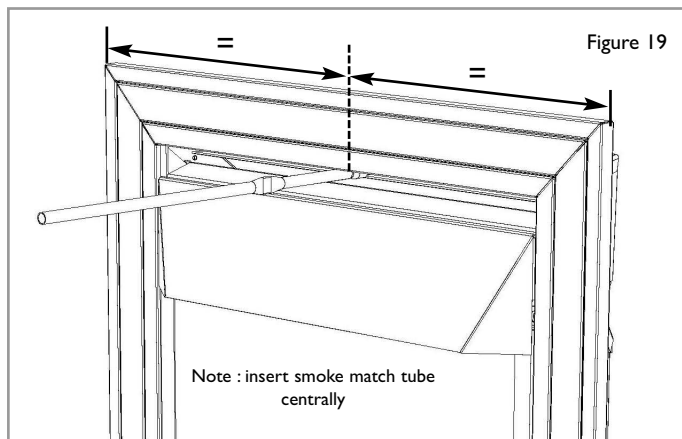

All the smoke should be drawn away up the flue.

Any smoke returning into the room indicates that spillage is occurring.

If the spillage test fails and the spigot restrictor is fitted, remove the spigot restrictor, re-fit and re-test. If the initial spillage test fails, run the fire for a further 10 minutes and repeat the test. When the test has been completed satisfactorily, repeat with any extractor fans in the premises running on the highest setting, and any communicating doors open. Finally, repeat with all doors open.

DO NOT allow the fire to be used until the test is satisfactorily passed.

10.0 BRIEFING THE CUSTOMER

All instructions must be handed to the user for safekeeping. Show the customer how to light and control the fire. After commissioning the appliance, the customer should be instructed on the safe use of the appliance and the need for regular servicing. Frequency of service depends on usage, but **MUST** be carried out at least once annually. Advise that cleaning of the fire may be achieved when the fire is cold using a damp cloth and mild detergent on most surfaces.

Scratched and other superficial damage to the matt black paintwork of the appliance can be covered with matching heatproof spray. Use only the manufacturers' recommended spray paint. Paint only when the fire is **OFF** and cold. Always mask off the surrounding area to prevent contamination with overspray. Ventilate the room during the use of the spray. **DO NOT** attempt to spray paint the coals or ceramics, or wash them in water.

Advise that the fire will emit a "newness" smell for a time after initial commissioning and that extra ventilation may be needed during this time. Advise that the fire is fitted with a spillage safety device (O.D.S.). If the fire shuts down, this system may be in operation. If spillage is suspected, **SWITCH APPLIANCE OFF** and call in the installer to investigate any problems.

11.0 SERVICING

Isolate the fire from the gas supply. Ensure that the fire is fully cold before attempting service. A suggested procedure for servicing is detailed below.

1. Lay out the dust sheet and tools.
2. Remove the hood, glass panel, and remove the ceramic components.
3. Remove the firefront and decorative trim.
4. Disconnect the gas supply, and remove the burner securing screws (refer to section 11.2)
5. Remove the burner tray.
6. Remove firebox as described.
7. Check the fireplace opening for rubble accumulation and remove. If debris is excessive, initiate remedial work on the flue.
8. Check the flue with smoke pellet for correct operation.
9. Vacuum clean inside of firebox removing all dust. Refit firebox.
10. Strip off the burner pipes and clean thoroughly. Refer to section 11.3.
11. Clean out the injector, pilot assembly and burner tube. **DO NOT** remove the pilot injector.
12. Vacuum clean tray, especially around the injector/venturi tube removing all dust. Re-assemble and re-fit the burner tray.
13. Clean the ceramic components - see section 11.1.
14. Turn on the gas supply, and leak test.
15. Refit the ceramic components, glass panel, hood, decorative frame and cast firefront as detailed in sections 9.2 and 9.3.
16. Light the fire and carry out a spillage test.
17. Check setting pressure and safe operation of the appliance.

For specific servicing instructions, see the relevant sections.

11.1 CLEANING THE CERAMIC PARTS

GB IE

Remove the firefront and place to one side. Remove the ceramic components. Gently clean in the open air. Be careful not to create dust from the coals. Where necessary replace damaged components with genuine spares. Seal scrap ceramic components in plastic bags and dispose at proper refuse sites as directed. Re-fit the coals by referring to section 10.0 of the user instructions.

11.2 REMOVING THE BURNER

Remove the firefront. Remove the hood, glass panel and ceramics and place safely aside.

Manual control models : Remove the two screws securing the tray legs to the firebox. Pull tray forward slightly and lift away.

Slide control models : Remove the four screws securing the tray to the firebox (two in the tray legs and two in the rear of the tray). Remove the M4 nut from the slide control linkage. Pull tray forward slightly and lift away. When re-fitting replace the rear retaining screws first, followed by the front (leg) retaining screws.

11.3 DISMANTLING THE BURNER

All models : Be sure to engage the tray location lugs on the shelf at the rear of the firebox.

Remove the tray as previously described. The pilot unit can be removed by withdrawing the tubing nut, the thermocouple nut on the valve, and the two securing screws, and lifting away. Remove the tubing nut from the valve end of the pilot pipe, and blow through to dislodge any debris. Remove the two tubing nuts on the ends of the gas pipe to the injector elbow and blow clear. Remove the two tubing nuts on the ends of the inlet pipe and blow clear.

Manual control models : The valve is not field serviceable.

Slide control models : The valve contains a gauze filter on the inlet manifold. Check that this is free from debris/obstruction.

11.4 PILOT ASSEMBLY

Remove the burner tray as in relevant section and pilot unit as described. Clean the pilot assembly with a soft brush and blow through. Remove the lint cage and clean. Check the aeration holes are free of any dirt or lint. Clean thoroughly internally, the connection can be removed from the base of the pilot unit using two spanners to make cleaning easier. Do not damage or try to remove the pilot injector. The unit is factory set and the only check necessary is to ensure the spark gap is correct. See section 2.0 Appliance data for gap setting. See section 9.1 for full details of the pilot assembly.

11.5 REMOVING THE FIREBOX

Remove the burner tray as described in section 11.2.

Protect the hearth from potential damage. Unroll the coiled tensioner cables from the rear of the firebox. Remove the securing nipples and tensioner adjusters. The firebox is now released from the opening and can be slid outward onto the hearth. Inspect the fire-place opening for debris and if excessive rectify the flue before proceeding further. Check the seal around the fireframe and if necessary replace. Refitting of the firebox is as described in the fitting section of these instructions.

12.0 TROUBLESHOOTING GUIDE

Fire sparks but pilot does not light

- No gas to fire, check isolators are open and gas supply is on.
- Pipework blockage, clean out.
- Air not fully purged, re purge supply or wait longer.
- Spark earthing to metalwork, reset gap correctly.
- Blocked pilot, clean out internally.

Pilot lights but then goes out

- Severe restriction in gas supply: clear obstruction.
- Faulty thermocouple, replace pilot unit.
- Blocked pilot, clean out.
- Blocked lint gauze, clean.
- Hold control knob in/down for longer.
- Slide control models only : Ensure that the slide control knob is pushed down **fully**.
- If the pilot will not stay lit there could be a problem with contamination of the gas supply, drafts, room size and/or ventilation or the thermocouple needs replacement.

Modifications are dangerous and can have a serious unseen effect on safety. NEVER MODIFY OR BEND THE THERMOCOUPLE TO MAKE THE PILOT STAY ALIGHT.

Fire does not spark at pilot

- HT lead detached, refit.
- Slide control models only - replace battery. See section 11.0 of the user instructions.
- Check the spark gap (see section 9.1).
- Faulty piezo unit, replace.
- Debris shorting out electrode, clean.
- Spark shorting to metalwork under tray, check routing of HT lead under burner.

Fire runs for a time and then cuts off

- Loose or faulty thermocouple, rectify.
- Blocked pilot, clean out.
- Excessive drafts in the room.
- Excessive flue pull.
- Fire is too close to an air vent.
- Dirt or lint in pilot aeration hole or on the lint gauze, clean thoroughly.
- If the pilot will not stay lit there could be a problem with contamination of the gas supply, drafts, room size and/or ventilation or the thermocouple needs replacement.

Modifications are dangerous and can have a serious unseen effect on safety. NEVER MODIFY OR BEND THE THERMOCOUPLE TO MAKE THE PILOT STAY ALIGHT.

Pilot flame shrinks when fire is on high

- Poor gas flow to fire, check pressure with fire on high.
- If pressure is low, remove any restriction in pipework or valve.
- Check all isolators are adequately sized and fully open.
- Check meter pressure is adequate.
- Firebox grommet seal missing, rectify.
- If the pilot will not stay lit there could be a problem with contamination of the gas supply, drafts, room size and/or ventilation or the thermocouple needs replacement.

Modifications are dangerous and can have a serious unseen effect on safety. NEVER MODIFY OR BEND THE THERMOCOUPLE TO MAKE THE PILOT STAY ALIGHT.

Fire smells when first lit or in use

- Newness smell from brand new appliance.
- Spillage occurring. Carry out Spillage test and rectify any problems.
- Combustible materials used in incorrect positions.
- Firebox grommet seal missing, rectify.
- Other airborne contaminants such as dust, tobacco smoke, paint vapours.

Section	Contents	Page No.
1.0	Important Notes	1
2.0	Firefront	1
3.0	Clearances To Combustibles	1
4.0	Fire Guards	2
5.0	Servicing	2
6.0	Ventilation	2
7.0	Operating The Appliance - Manual Control Models	2
7.1	Operating The Appliance - Slide Control Models	3
8.0	Flue Spillage Monitoring System	3
9.0	Cleaning	3
10.0	Fuel Bed Layout	4
11.0	Changing The Battery (Slide Control Models)	4
12.0	Cleaning The Ceramic Parts	4
13.0	Shortlist Of Spares	4
14.0	Installation Details	5
15.0	Service History	5
16.0	Guarantee - Terms and Conditions	6

1.0 IMPORTANT NOTES

- The Installation and Servicing of this fire **MUST** only be carried out by a **GAS SAFE** registered person in accordance with local Codes and/or Regulations, Building Regulations and the manufacturer's instructions. Failure to comply with these could lead to prosecution and invalidate the appliance warranty. In the event of gas leakage from the appliance, the gas supply must be turned off at the nearest isolating valve. This appliance is only suitable for the gas type for which it is supplied.
- Keep a note of the installer's name and address, the original purchase receipt and the date of installation. Failure to produce this information may invalidate the warranty. The appliance should be serviced regularly to ensure continued safe operation. See the servicing section for further reference. Frequency of service will depend on use, but **MUST** be carried out at least once annually.
- Parts of this appliance become naturally hot during use. It is recommended that a suitable fireguard is used, especially where young children, pets, the elderly or infirm are concerned. The manufacturer of this appliance considers all surfaces as working surfaces with the exception of the control knob and control panel.
- **As with any gas fire, a fire guard complying with BS 8423 must be used in presence of pets, children, and the elderly or infirm.**
- The appliance should be serviced regularly to ensure continued safe operation. Frequency of service will depend on use, but **MUST** be carried out at least once annually.
- Combustible items, such as flooring and furniture and soft wall coverings (such as blown vinyl or embossed paper), low temperature surrounds etc may discolour if fitted too close to the fire. See relevant section for further details on clearances to combustibles. No combustible materials or flooring should protrude onto the hearth.
- This appliance incorporates a combustion monitoring system (ODS).
- **DO NOT** burn any foreign material on this fire, the ceramic fuel effect components must be of the correct type and laid out in accordance with the relevant section of these instructions.
- Failure to do so could create a hazard or lead to sooting.
- Before the appliance is installed, the chimney should be swept. All flues should be checked by the installer to ensure there are no defects or obstructions that may prevent the flow of combustion products.
- This appliance is fitted with a flue blockage safety device which will shut down the fire if abnormal flue conditions occur. It is **NOT** a substitute for an independently mounted Carbon Monoxide detector.
- Should any home improvements be carried out to the property after the fire is installed, such as installation of extractor fans for example, the fire should be re-checked by a competent person for safe operation.

2.0 FIREFRONT

This fire is supplied with a particular style of firefront. Use of the firefront will ensure an adequate airflow under the firebed for the correct functioning of this appliance. Compliance with safety standards cannot be guaranteed if another style of front is used.

3.0 CLEARANCE TO COMBUSTIBLES

<i>Maximum depth of shelf</i>	<i>Minimum distance from finished hearth surface to underside of shelf</i>
100mm (4in)	745mm (29 ¹ / ₄ in)
150mm (6in)	845mm (33 ¹ / ₄ in)
203mm (8in)	895mm (35 ¹ / ₄ in)

A combustible shelf may be fixed to the wall above the fire, providing that it complies with the dimensions given below.

A non-combustible shelf may be fitted to within 10mm of the top edge of the fireframe. Combustible materials, such as wood, may be fitted to within 100mm (4in) of either side of the frame of the appliance, providing the forward projection does not exceed 100mm (4in). Any combustible side walls must be at least 500mm to the side of the radiant heat source. As with all heating appliances, any decorations, soft furnishings, and wall coverings (i.e. flock, blown vinyl and embossed paper) positioned too close to the appliance may discolour or scorch.

4.0 FIRE GUARDS

GB IE

The fireguards specified in BS 8423 are intended to protect people from falling into a fire, prevent burns and reduce the risk of injury, particularly to young children and the infirm. In addition it is intended to reduce the risk of fire resulting from clothing and/or other flammable materials coming into contact with, or in proximity to, burning fuel and/or hot surfaces.

Fireguards can be permanently fixed in position or can be moveable, and can incorporate open fires including combination grates, or closed fires, including room heaters and stoves. **See figures 1 & 2 for fireguard examples.**

The fireguards specified are not intended to reduce the risk of fires caused by flying particles, which are covered by BS 3248.

Figure 1
Example of moveable fireguard for portable heating appliances

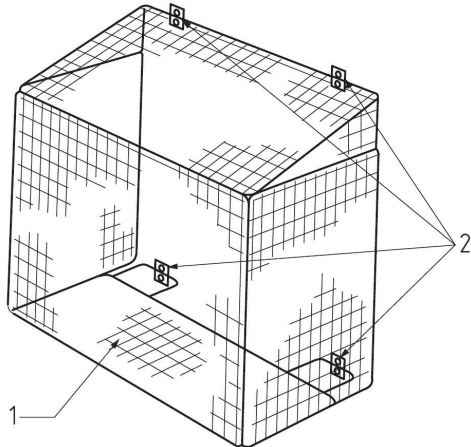

Key
1. Optional base section for total enclosure of a wall mounted appliance
2. Points for attachment to a wall.

Figure 2
Example of detachable fireguard

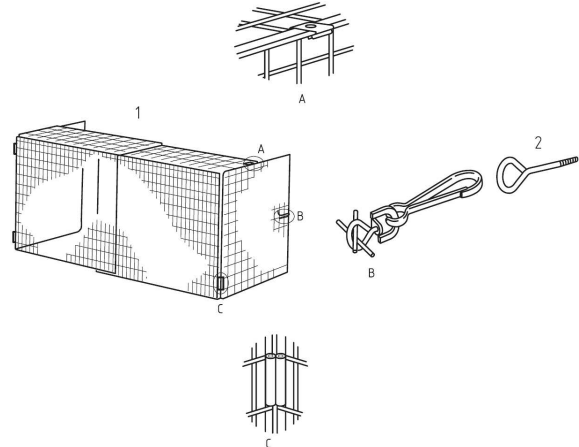

Key
1. Detachable fireguard
2. Screw eye

5.0 SERVICING

The fire and flue should be checked on an annual basis to ensure all of the product of combustion are entering the flue and that there is no excessive build up of soot. The frequency of service will depend on usage, but **MUST** be carried out at least once annually. Servicing must be carried out by a GAS SAFE registered person.

Cleaning of the coals may be carried out by following the instructions given in the Installation section. The Installation instructions carry full servicing details for the use of the installer.

If debris from the flue or other foreign matter is found on the fire it may indicate a need for servicing. Do not use the fire until the source of the debris has been found and rectified. Air vents (where fitted) should be checked periodically to ensure they are free from obstruction.

6.0 VENTILATION

No purpose provided ventilation is normally required for this appliance. The requirements of other appliances operating in the same space or room, and the results of a spillage test must be taken into consideration when assessing ventilation requirements, this will have been carried out by your registered installer. For Republic of Ireland, ventilation may be required, see IS 813, ICP3, IS 327, and any other rules in force

7.0 OPERATING THE APPLIANCE

The pilot is visible through the viewing hole which is located at the lower left hand side of the fuel bed. The fire features a 'twin spark' ignition system to aid lighting, Push the control knob in fully and turn anti-clockwise through both of the SPARK positions, keeping fully depressed, hold there for a few seconds. If the fire has not been used for some time, hold the knob in this position for longer, to allow any air in the pipes to be purged. Continue turning anti-clockwise through the spark clicks to the nine o'clock position, ensuring the pilot has lit. If not, return the knob clockwise, and repeat. When the pilot lights after one of the two sparks, keep the knob depressed in the nine o'clock position for approximately ten seconds. Now release the knob and the pilot should stay alight. If the pilot is extinguished during use, wait three minutes before repeating the ignition procedure.

To achieve the HIGH setting, push the control knob in slightly and continue turning anti-clockwise to the high position. The main burner should light after a few seconds. To decrease the setting to LOW, push the knob in slightly and turn the control knob clockwise to the low setting. To turn to the pilot only position from the HIGH or LOW positions, press the control knob in, and return to the nine o'clock position and release. To turn the fire OFF, keep the knob pressed in, return to the off position and release.

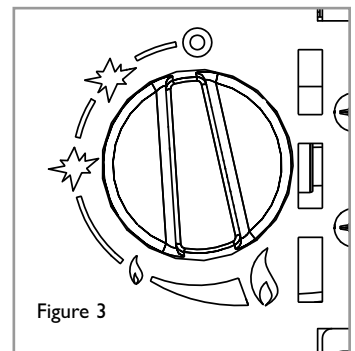

The pilot is visible through the viewing hole which is located at the lower left hand side of the fuel bed.
 Push the slide control knob fully downwards to the SPARK position, and hold there for approximately ten seconds. Now release the knob and the pilot should stay alight. When the pilot light has established, move the slide control knob upwards to the LOW flame setting. If the pilot is extinguished during use, wait three minutes before repeating the ignition procedure. To achieve the HIGH setting, move the slide control knob upwards to the HIGH flame setting. The fire can also be set to operate anywhere between HIGH and LOW by moving the control knob to an intermediate position.
 To turn the fire OFF, move the slide control knob upwards fully to the position marked 'O'.

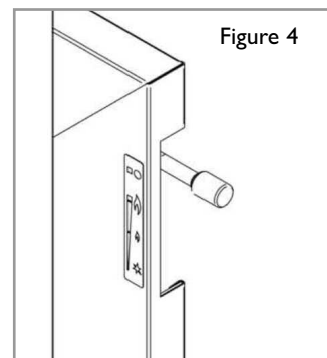

8.0 FLUE SPILLAGE MONITORING SYSTEM

This fire is fitted with a flue spillage safety device (ODS). If the fire shuts down during use for no apparent reason then several reasons may be suspected. If a door or window has been opened creating a draught, then pilot disturbance could be the problem, and removal of the draught should resolve this. The fire can then be re-lit in accordance with the previous section. A grommet seal may also be missing from the firebox causing abnormal draught to shut down the pilot. Call your installer to check seals are properly fitted. If pilot disturbance is not the cause, then the ODS safety system may be in operation. Switch the appliance OFF, call in your installer to check the flue and ventilation and carry out any remedial work required. DO NOT allow the appliance to be used until the flue system is passed as safe.

9.0 CLEANING

Before carrying out any of the following operations, ensure that the fire is OFF and completely cold. Debris that may form on the firebed should be periodically removed by a competent person. Large deposits could indicate deterioration of the flue. This should be repaired by a competent person, and the fire serviced before further use.

FIREFRONT - Any dust accumulating in the firefront may be removed using a vacuum cleaner or dry cloth. Heavy stains may be removed by using a damp cloth and mild household detergent. Brass parts of the firefront may be cleaned using a suitable brass cleaner. Replace the front centrally against the fire after cleaning.

PAINTED AREAS - These can be cleaned using a dry cloth.

GLASS PANEL - Remove the firefront casting and place to one side and then refer to section 9.3 of the installation instructions and follow in reverse order. Remove the glass panel assembly by removing the four retaining screws. Once removed this can be cleaned with a suitable glass cleaner. Test on a small area first. Re-install on to the fire in the correct order.

10.0 FUEL BED LAYOUT

1. Remove the ceramic components from their protective packaging, and place the brick panel against the rear of the firebox. Place the ceramic combustion matrix onto the burner.

2. Place the moulded coal piece marked on the underside 'A' onto the matrix as shown in figure 5.



3. Place the moulded coal piece marked on the underside 'B' onto the matrix as shown in figure 6.



4. Place the moulded coal piece marked on the underside 'C' onto the matrix as shown in figure 7.



Figure 7

5. Place the moulded coal piece marked on the underside 'D' onto the matrix as shown in figure 8.



Figure 8

6. With pieces 'A' to 'D' correctly in position, the fuel bed should appear as shown in figure 9.

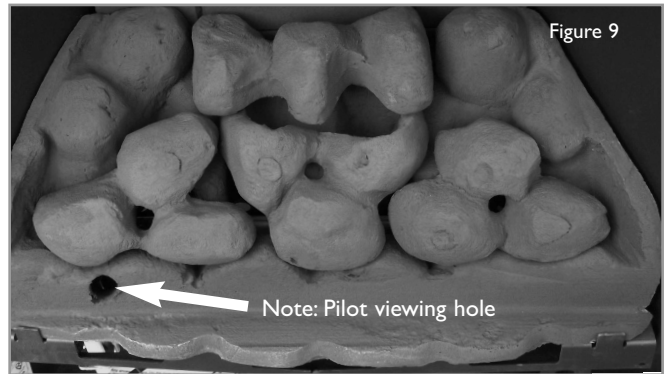

Figure 9

Note :If during commissioning it is discovered that the flames are hitting the glass panel, it may be necessary to slightly tilt ceramics A and/or C forward away from the flame ports. The fire is designed to operate correctly with only the ceramic coal pieces supplied when assembled according to these instructions. Never add extra ceramics, or change them for a different type. Never throw rubbish or other matter onto the fuelbed.

11.0 CHANGING THE BATTERY (SLIDE CONTROL MODELS)

Ensure appliance is off and cool. The battery is located in the front of the ignition unit, on the right hand side of the burner (shown in figure 10). Unscrew the battery holder cap. Insert 1 x 'AA' (1.5 volt) battery. Replace cap.

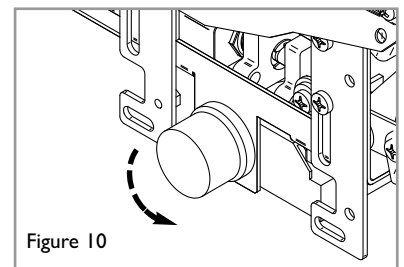

Figure 10

12.0 CLEANING THE CERAMIC PARTS

In the unlikely event that the ceramic parts need to be cleaned, remove the firefront casting and place to one side and then refer to sections 9.2 and 9.3 of the installation instructions and follow in reverse order. Remove the glass panel assembly by removing the four retaining screws. Remove the ceramic components. Gently clean in the open air using only a soft, dry brush. Be careful not to create dust from the ceramics. Where necessary replace damaged components with genuine spares. Seal scrap ceramic components in plastic bags and dispose at proper refuse sites as directed. Re-fit the ceramic parts by referring to sections 9.0 of these instructions.

13.0 SHORTLIST OF SPARES

PART NO.	ITEM	PART NO.	ITEM
F550324	Pack of coal pieces 'A, B, C, D'	F960021	Glass panel assembly
F780105	Ceramic combustion matrix - coal	F730067	Gas Valve (slide control)
F550208	Ceramic rear pad	F730085	Gas Valve (manual control)
F730080	Injector (size 65)	F730023	ODS Oxypilot 9082
F730083	Injector (size 66)	F730006	ODS Oxypilot 9081
TRAY154	Burner assembly (slide control)	F730108	ODS Oxypilot 21100 2F/ 297
TRAY100C	Burner assembly (manual control)		

14.0 INSTALLATION DETAILS

GB IE

Model :

Installer GAS SAFE registration no. :

Date installed :

Fire serial No. :

Name & contact details of installer :

Supplied by :

15.0 SERVICE HISTORY

Date of service	Serviced by (name):	GAS SAFE No. :	Contact details of Engineer

The 3 year guarantee only covers products purchased on or after 1st February 2009. For all gas fires purchased the 3 year guarantee commences from the date of purchase, provided that the following 3 terms and conditions are adhered to:

Registration is not required.

1. For any claim to be made within the 3 years from date of purchase you will be required to provide and supply us with your proof of purchase.
2. Your gas fire must have been commissioned by a CORGI/Gas Safe* registered installer, evidence of which you must provide together with the CORGI/Gas Safe* registration number.
3. Your appliance must have been serviced annually, irrespective of use, by a CORGI/Gas Safe* registered installer, evidence of which must be provided, such as the receipt.

Please note all consumable items such as any ceramics including: coals, pebbles, the matrix, front strips, side cheeks, rear panels and tapered rear panels are not covered by the 3 year guarantee. For all Electric fires purchased the 3 year guarantee commences from the date of purchase, providing that you can supply the proof of purchase. This does not cover consumable items such as pebbles, coals or light bulbs.

Making a claim is easy.

If you wish to make a claim under our 3 year guarantee and all the terms and conditions for your product have been met then please submit the following information for the attention of the 3G Service Department to the address below. Alternatively, you can email or fax. Please note that this does not affect your statutory rights.

Focal Point Fires plc, 3G Service Department, Reid Street, Christchurch, Dorset, BH23 2BT.
Alternatively email: 3g@focalpointfires.co.uk or fax. 01202 499326.

Details required:

1. Name, full address including post code and contact telephone number.
2. Receipt of purchase or credit card statement.
3. Original installers CORGI/Gas Safe* registration number (gas fires only).
4. Annual service receipt for every 12 months (gas fires only).

*Gas Safe Register replaced CORGI as the gas registration body in Great Britain and the Isle of Man on 1st April 2009.

Product Fiche

Supplier's name or trademark; **Focal Point Fires**

Model identifier; **High Efficiency (Glass Fronted) Inset Fuel Effect Gas Fire**
Gas Category/Pressure = **I_{2H}(20)**

Energy Efficiency Class of the model; **C**

Direct heat output; **4.1 kW**

Indirect heat output; **N.A.**

Energy Efficiency Index; **81**

Useful Energy Efficiency at nominal heat output; **90.0%**

Useful Energy Efficiency at minimum load; **90.0%**

Specific precautions that shall be taken when the local space heater is assembled, installed or maintained;

This appliance must be installed, commissioned and maintained by a competent person. Prior to installation the competent person must ensure that the local distribution conditions (identification of the type of gas and pressure) and adjustment of the appliance are compatible.

The competent person must refer to and comply with the specific instructions listed in the Installation Manual before starting to install and commission the appliance.

Table 1

Information requirements for gaseous/liquid fuel local space heaters

Model identifier(s):		High Efficiency Glass-Fronted Gas Fires					
Indirect heating functionality:		[yes/no]					
Direct heat output:		4.1 (kW)					
Indirect heat output:		N.A.					
Fuel				Space heating emissions(*)			
				NO _x			
Select fuel type		[gaseous/liquid]	[specify]	[mg/kWh_{input}] (GCV)			
		Gaseous	Natural Gas	< 130 t.b.c.			
Item	Symbol	Value	Unit	Item	Symbol	Value	Unit
Heat output				Useful efficiency (NCV)			
Nominal heat output	P_{nom}	4.1	kW	Useful efficiency at nominal heat output	$\eta_{th,nom}$	90.0	%
Minimum heat output (indicative)	P_{min}	2.8	kW	Useful efficiency at minimum heat output (indicative)	$\eta_{th,min}$	90.0	%
Auxiliary electricity consumption				Type of heat output/room temperature control (select one)			
At nominal heat output	e_{lmax}	0.0	kW	single stage heat output, no room temperature control	[yes/no]		
At minimum heat output	e_{lmin}	0.0	kW	two or more manual stages, no room temperature control	[yes/no]		
In standby mode	e_{lSB}	0.0	kW	with mechanic thermostat room temperature control	[yes/no]		
				with electronic room temperature control	[yes/no]		
				with electronic room temperature control plus day timer	[yes/no]		
				with electronic room temperature control plus week timer	[yes/no]		
				Other control options (multiple selections possible)			
				room temperature control, with presence detection	[yes/no]		
				room temperature control, with open window detection	[yes/no]		
				with distance control option	[yes/no]		
				with adaptive start control	[yes/no]		
				with working time limitation	[yes/no]		
				with black bulb sensor	[yes/no]		
Permanent pilot flame power requirement							
Pilot flame power requirement (if applicable)	P_{pilot}	N.A.	kW				
Contact details	Focal Point Fires Plc. 10 Avon Trading Park, Christchurch, Dorset, BH23 2BT						
(*) NO _x =nitrogen oxides							