

# Assembly Instructions

## Sliding Shower Enclosure

---

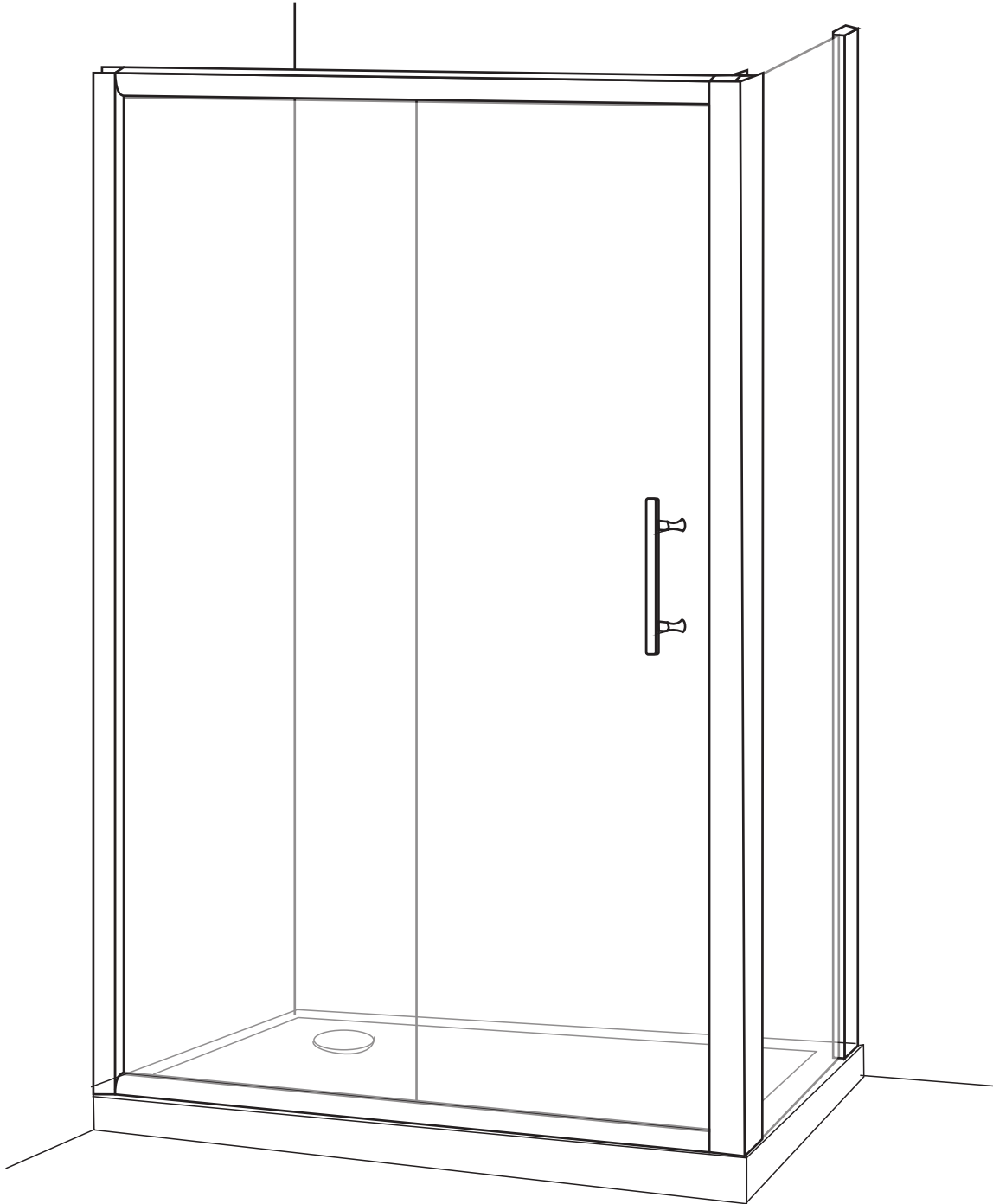













Product Reference(Barcode): MBIES1202(5034109088909)  
MBIEI7604(5034109091565)  
MBIEI8004(5034109091572)  
MBIEI9004(5034109091589)

---

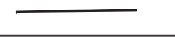
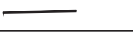





# Assembly Instructions Sliding Shower Enclosure

## Contents for Sliding Door

### Parts Supplied



Ref	Description	Illustration	Qty
A	TOP AND BOTTOM TRACK FRAMES		2
B	F-SHAPED WALL PROFILE		2
C	FIXED DOOR		1
D	SLIDING DOOR		1
F	VERTICAL SEAL		2
H	SLIDING GLASS PROFILE		1
I	MAGNETIC DOOR SEAL		1
M	SPLASH SEAL		2
A2	HANDLE		1
B2	TOP ROLLER		2
C2	BOTTOM ROLLER		2
D2	GLASS CLIP AND COVER CAP		2
M3	ROLLER WASHER		4

### Fittings Supplied





Ref	Description	Illustration	Qty
E2	stainless steel screws: 4*35		8
F2	stainless steel screws: 4*25 plastic screw washer screw cover		8
G2	stainless steel screws: 4*10		2
H2	stainless steel screws: 4*10 plastic screw washer screw cover		8
I2	expandable wall plug		8
K2	3mm Drill bit		1

## Contents for Side Panel(Sold Separately)

### Parts Supplied

Ref	Description	Illustration	Qty
B1	U-SHAPED WALL PROFILE		1
E	SIDE PANEL		1
G	CORNER PROFILE		1

### Fittings Supplied









Ref	Description	Illustration	Qty
F3	stainless steel screws: 4*25		4
H2	stainless steel screws: 4*10 plastic screw washer screw cover		8
I2	expandable wall plug		4
K2	3mm Drill bit		1

# Assembly Instructions

## Sliding Shower Enclosure

---

### Tools Required (not supplied)

Picture	Description	Picture	Description
	5.5mm Drill Bit suitable for type of wall fixing to be used		Spirit Level
	Scissors		Pencil
	Magnetic Crosshead Screwdriver		Rubber Mallet
	Power Drill(with hammer action)		Tape Measure
	Silicone Sealant		

### Before You Start

- **WARNING** : Please read these instructions through carefully before you start the installation. Incorrect product installation may result in serious product failure in use. Always follow the instructions and retain them for future use.
- The enclosure is designed to allow for 10mm adjustment for side panel and 15mm adjustment for sliding door, when fitted to “out of true” walls.
- The thickness of the tiles used will affect the overall position of the enclosure on the tray.
- Check the pack and ensure that you have all of the parts listed above. If not, contact Customer Services ( UK only ) on 0845 313 0386.
- When you are ready to start, make sure you have the right tools to hand, plenty of space and a clean dry area for assembly.
- Two people are required for assembly. Please note that although these instructions are comprehensive, it is always recommended that a technically competent installer should undertake installation.
- Ensure that the enclosure is fitted to a level tray or floor and vertical walls .
- **Please note:** The wall plugs included with this product are suitable for solid walls only. Plasterboard or stud walls may require specialized fixings which are not provided. (Always ensure that the wall plugs or fittings are correct for the wall type.)
- **Caution:** Please handle all glass with care. Any damage to the edges, or scratches to the surface that occur during assembly or normal use can cause the glass to break suddenly. Tempered glass will shatter into very small pieces that will still have sharp edges.
- **Caution:** Care should be taken when drilling into walls to avoid hidden pipes or electrical cables.
- When working near a tray or bath, ensure that the waste is covered so that small parts do not fall down it.

# Assembly Instructions

## Sliding Shower Enclosure

### Sliding Door Assembly

1. Before fixing the shower door, ensure the shower tray at the base is properly installed and fully silicone sealed.

Note: The sliding door can either be installed on the right or left hand side, as per Fig.1. Decide which side the door is to be fitted before you start.

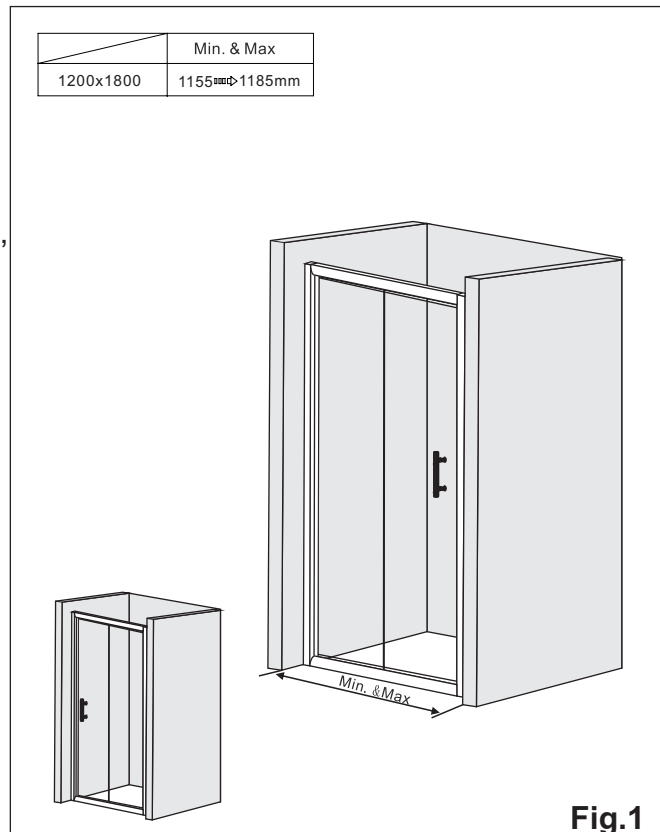

2. Push the splash seals(M) onto the top and bottom of the fixed glass panel(C) and trim to the correct lengths as illustrated in Fig.2.

Note: Ensure the taller side of the splash seal is fitted to the outside of the door.

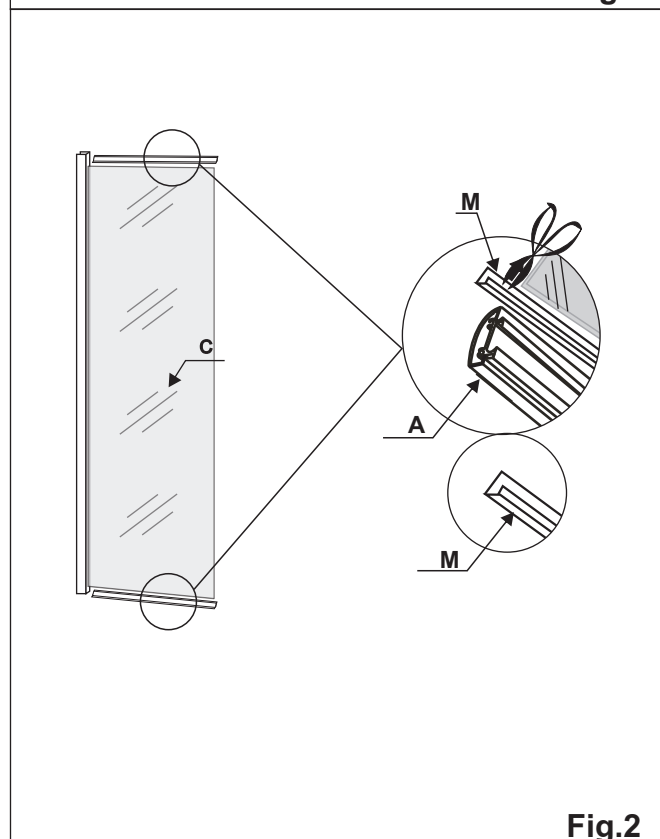

# Assembly Instructions

## Sliding Shower Enclosure

3a. Fit the top and bottom track frames(A) to the fixed door(C) using screw ST4\*35mm (E2). See **Fig. 3**.

3b. Fit the sliding glass profile(H) to the top and bottom track frames(A) using screw ST4\*35mm(E2). See **Fig. 3**.

Note: Ensure the end of the track frame with the slider bump stop on it is assembled to the fixed glass(C).

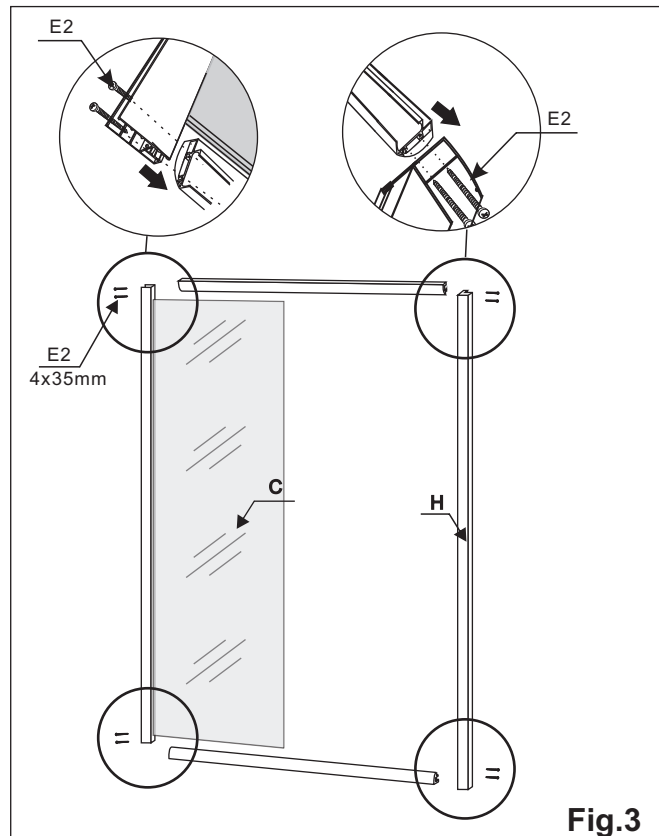

4. Insert the glass clips(D2) into the top and bottom track frames(A). Secure the clips with screw ST4\*10mm(G2) and place the cover caps onto the clips as per **Fig. 4**.

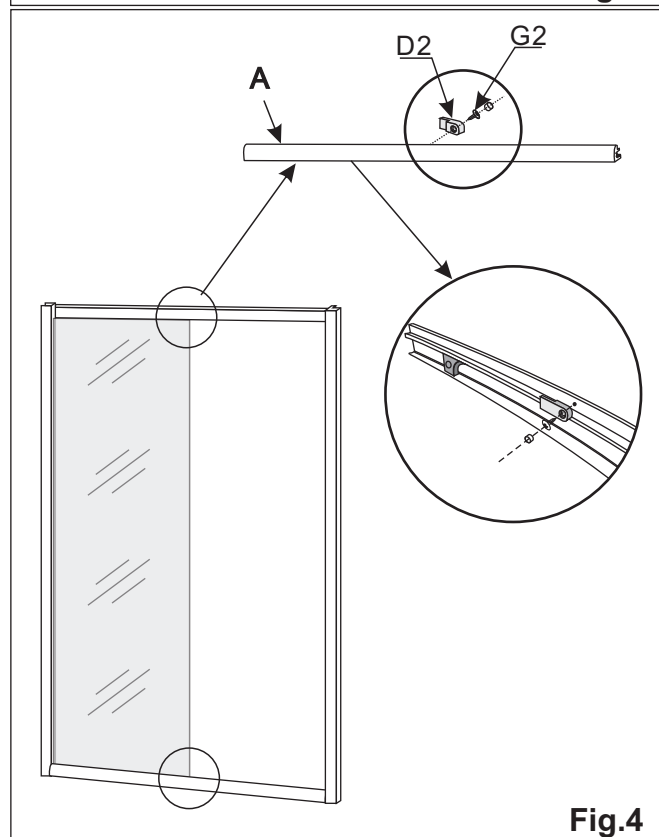

# Assembly Instructions

## Sliding Shower Enclosure

---

5. Insert the two F-shaped wall profiles(B) into the side profile of the fixed glass(C) and the sliding glass profile(H), ensuring the correct orientation of the flanges, as per **Fig.5**.

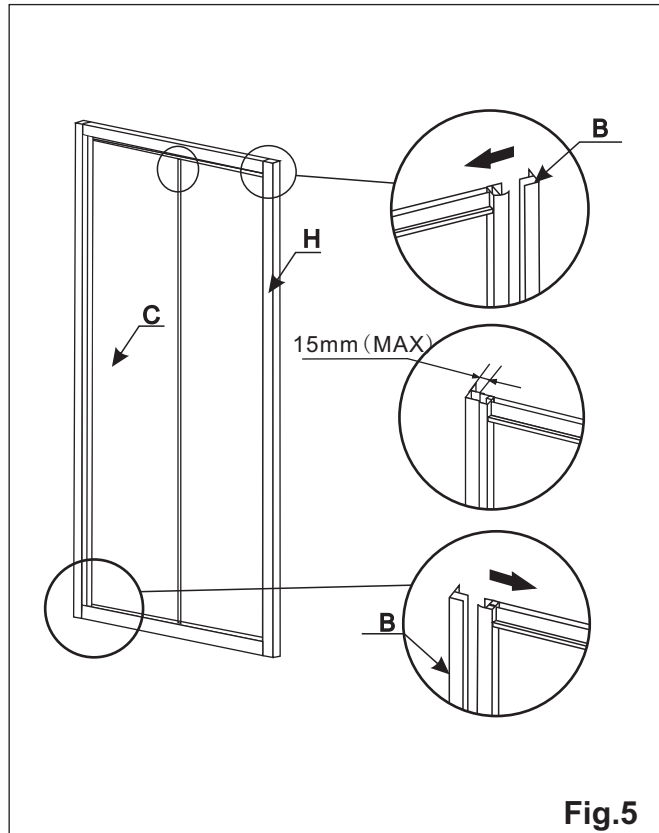

6a. Place the shower door on the shower tray, and position it so that there is an even gap to the edge of the tray.

6b. Adjust the two wall profiles so that they sit flush to the walls, and use a spirit level to ensure that they are both vertical. See **Fig.6**.

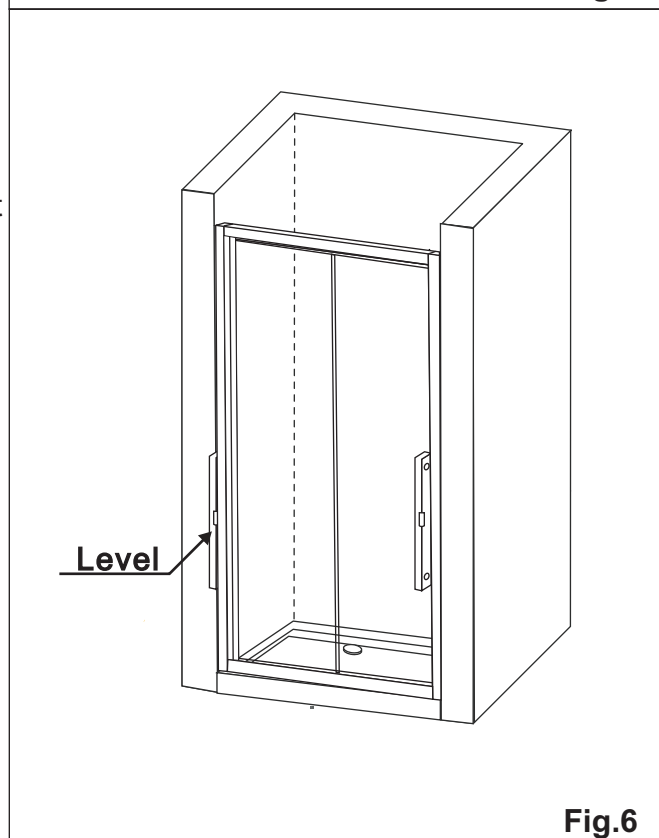

# Assembly Instructions

## Sliding Shower Enclosure

7a. Taking care not to move the door, use the pre-drilled holes in the wall profiles(B) as a template and mark the hole positions on the wall with a pencil. See **Fig. 7**.

7b. Remove the door and drill the holes with a drill bit suitable for the wall type and fixing being used. Insert the wall plugs(I2) into the holes using a rubber mallet.

7c. Apply silicone sealant to the back of one of the F-shaped wall profiles(B) and secure it to the wall where the magnetic strip will be located using the plastic screw washers and screw ST4\*25mm(F2). Cover them with screw covers as per **Fig. 7**.

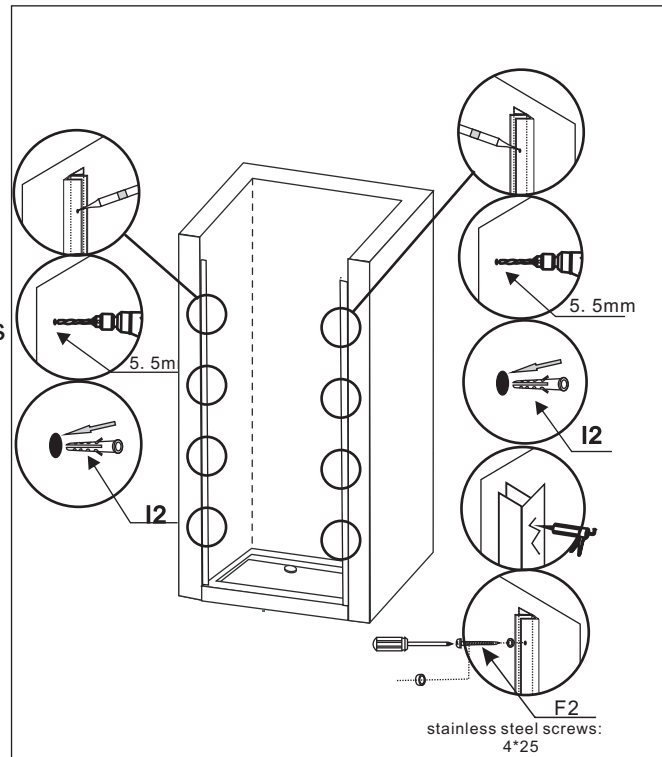
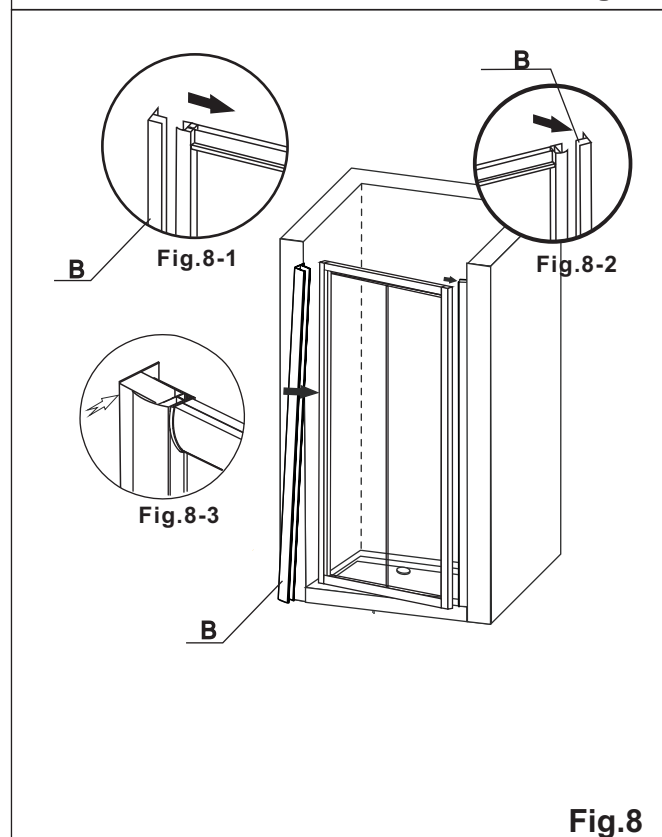

**Fig.7**

8a. Apply silicone sealant to the back of the other F-shaped wall profile(B) and insert it into the door side profile nearest to the fixed door. See **Fig. 8-1**.

8b. Fix the door side profile with the magnetic strip over the F-shaped wall profile(B) and push fully home. See **Fig. 8-2**.

8c. Position the other side of the door so that the holes in the wall profile line up with the holes in the wall. See **Fig. 8-3**.



**Fig.8**

# Assembly Instructions

## Sliding Shower Enclosure

---

9. Secure the F-shaped wall profile to the wall using plastic screw washers and screw ST4\*25mm(F2). Cover them with screw covers. See **Fig. 9**.

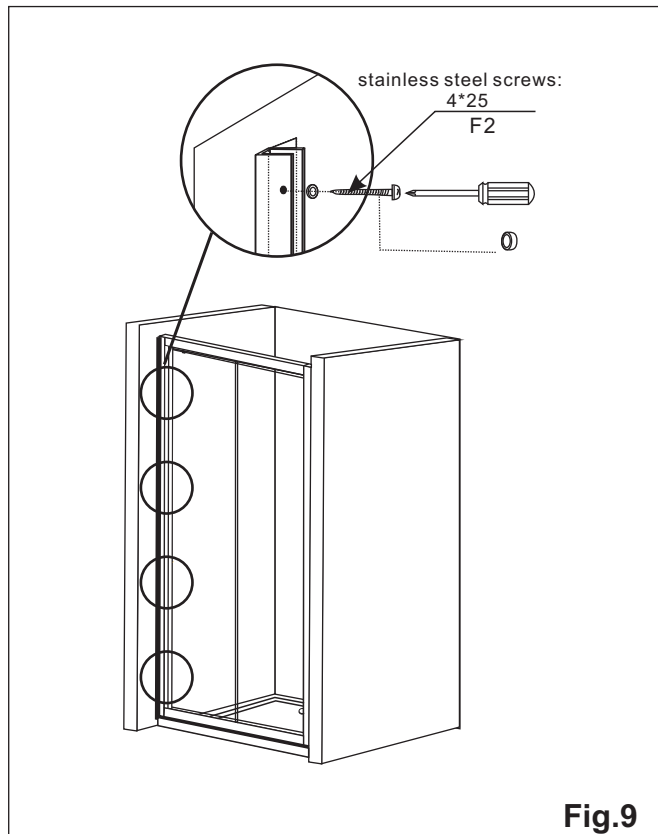

10. Fit the door handle(A2) onto the sliding door(D). Note that the rubber washers should be on both sides of the glass as per **Fig. 10**.

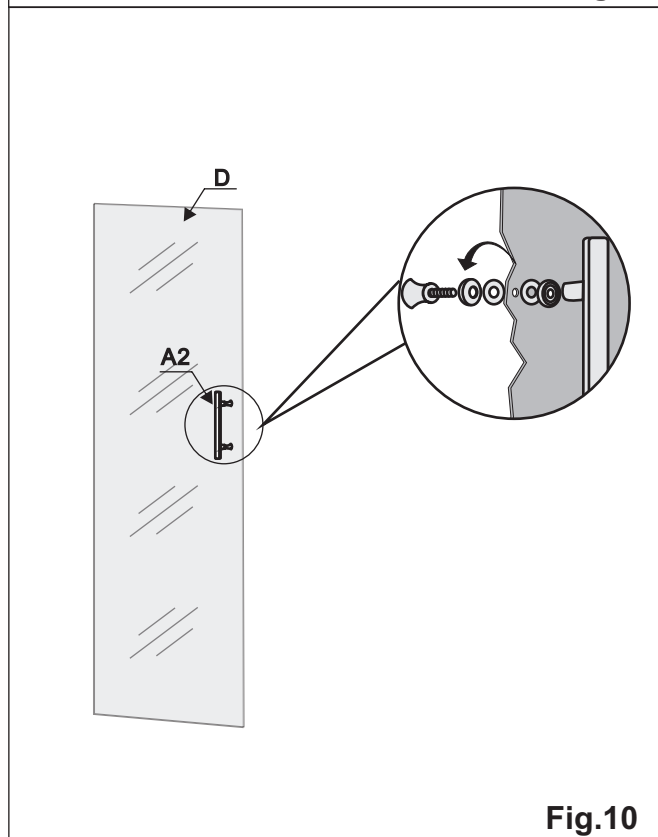



# Assembly Instructions

## Sliding Shower Enclosure

---

11. Fit the rollers(B2 & C2) onto the sliding door(D).

Make sure the correct rollers are fitted to the top and bottom of the door.

Please note that a rubber washer (M3) should be fitted between the door roller and the glass.

Secure the rollers on the door using a cross-headed screwdriver.

Push the cover caps over the screws on the rollers. See **Fig.11**.

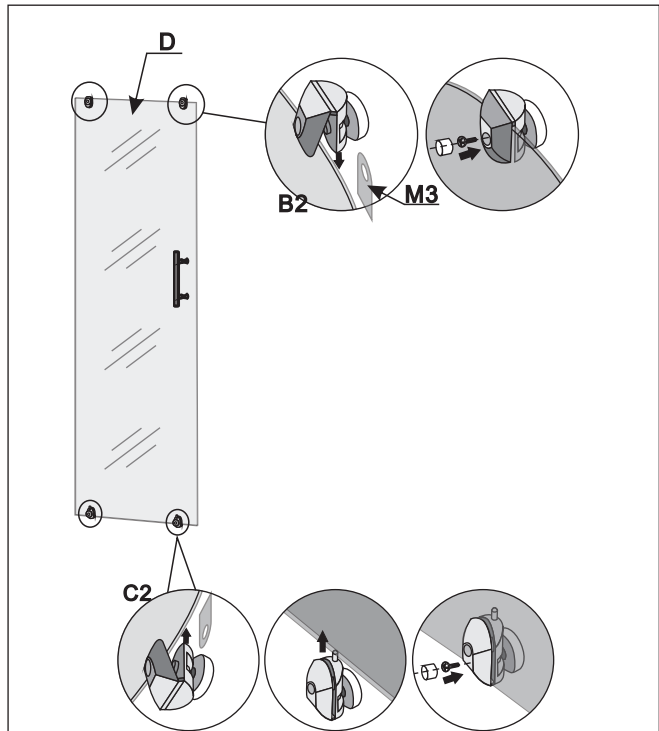

**Fig.11**

12. Cut the magnetic seal(I) to a suitable length and push onto the side of the sliding door(D) as per **Fig. 12**.

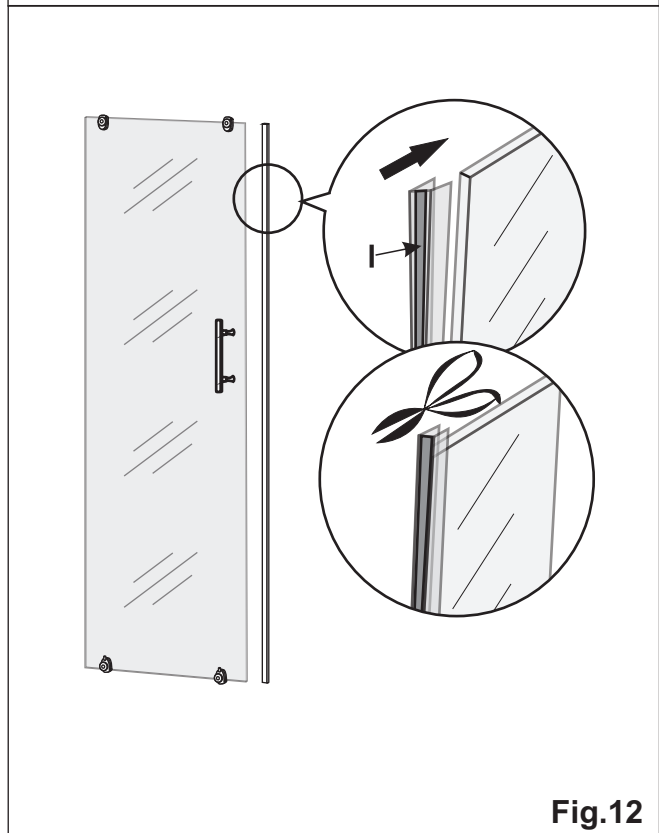

**Fig.12**

# Assembly Instructions

## Sliding Shower Enclosure

13a. Tilt the bottom of the door(D) into the enclosure, and locate the top rollers(B2) in the channel in the top track frame(A).

13b. Push down on the bottom rollers and locate them into the channel in the bottom track frame(A).

13c. To ensure that the sliding door(D) is hanging vertically and runs smoothly, adjust the top rollers(B2) by rotating the screw thread at the bottom. Raise and lower the door on both top rollers as required to minimize the gap between the door and the sliding glass profile and make sure the door runs smoothly.

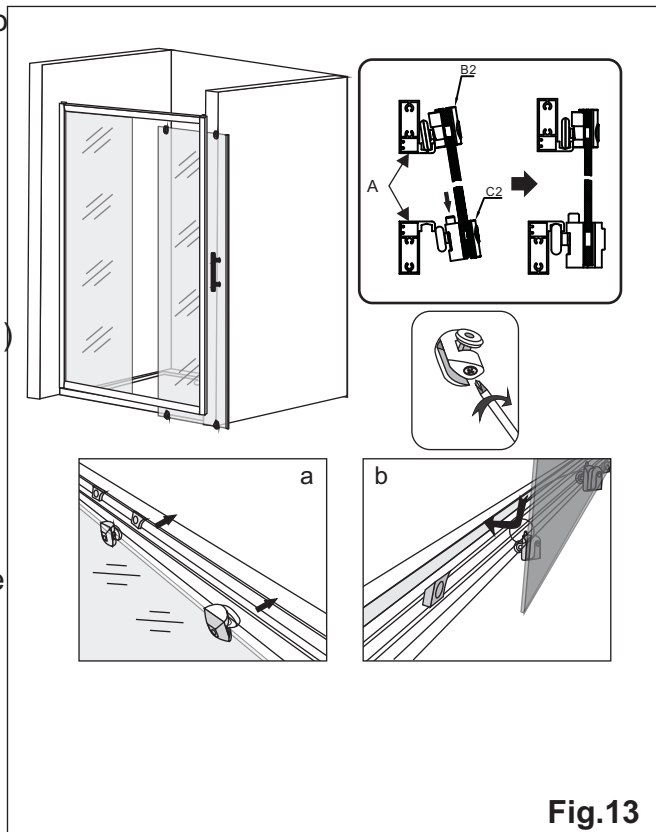

14. Push the vertical seals(F) onto the fixed door and sliding door, and cut them into suitable lengths as per **Fig.14**.

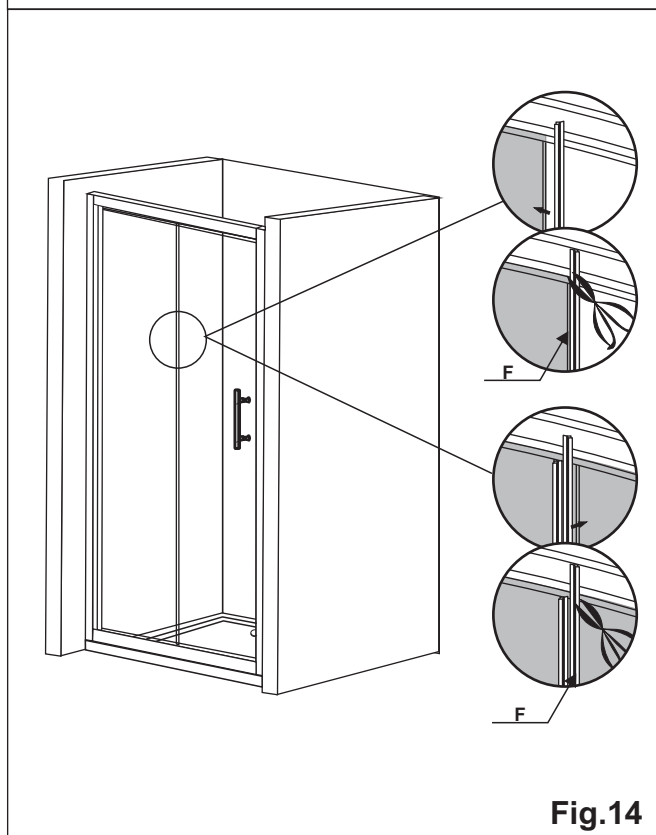

# Assembly Instructions

## Sliding Shower Enclosure

15a. Using a spirit level ensure that the door is vertical, and position it as evenly as possible between the two walls.

15b. Taking care not to move the door, use a 3mm drill bit(K2) to drill through the side profile and wall profile from the inside of the sliding door. Do not drill through the front of the profiles. Secure the profiles using plastic screw washers and screws ST4\*10mm(H2). Clip the screw covers on as per **Fig. 15**.

**CAUTION:**  
THE GLASS IS RETAINED IN THE PROFILES TO A DEPTH OF 10MM. Under no circumstance should it be attempted to drill through the profiles in this region. Damage to the glass and injury may occur.

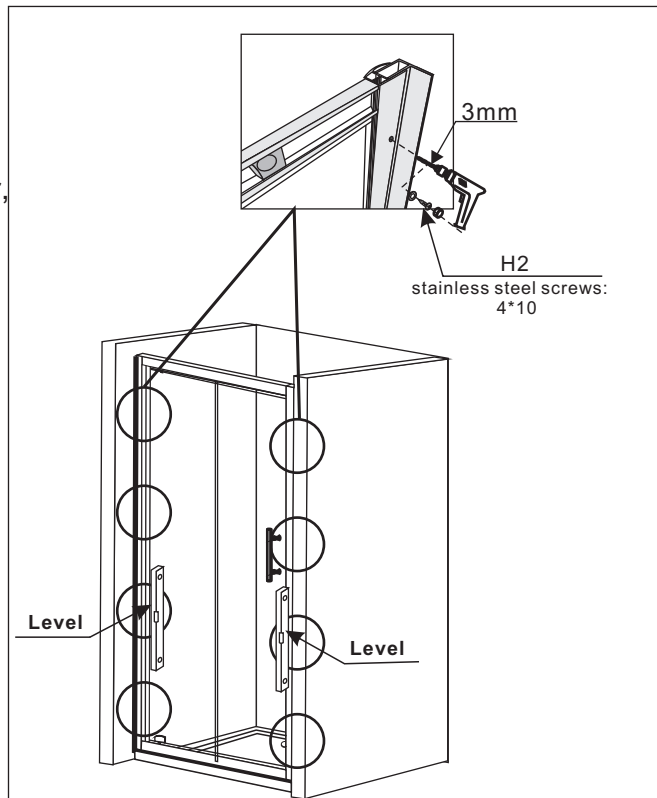
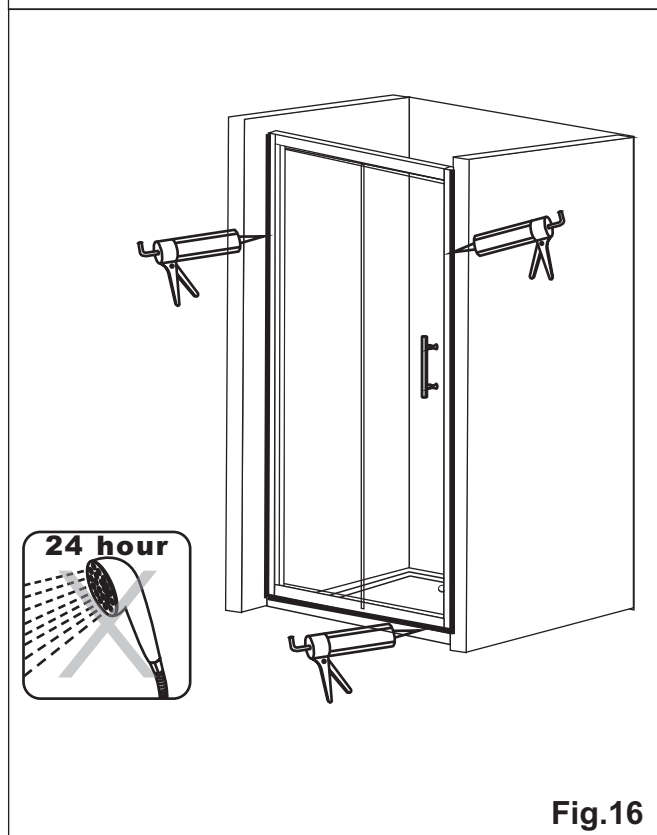

**Fig.15**

16. Apply silicone sealant to the joints on the outside of the shower door only as indicated by the thick line in **Fig.16**.

Note: If silicone is applied to the inside of the door as well, it can cause the water to remain trapped and build up, eventually causing leaks.

Note: Do not use the shower door for at least 24 hours in order to allow the silicone to cure fully.



**Fig.16**

# Assembly Instructions

## Sliding Shower Enclosure

### Sliding Enclosure Assembly

1. Before fixing the shower enclosure ensure the shower tray at the base is properly installed and fully silicone sealed.

Note: The sliding enclosure can either be installed on the right or left hand side, as per **Fig.1**. Decide which side the enclosure is to be fitted before you start.

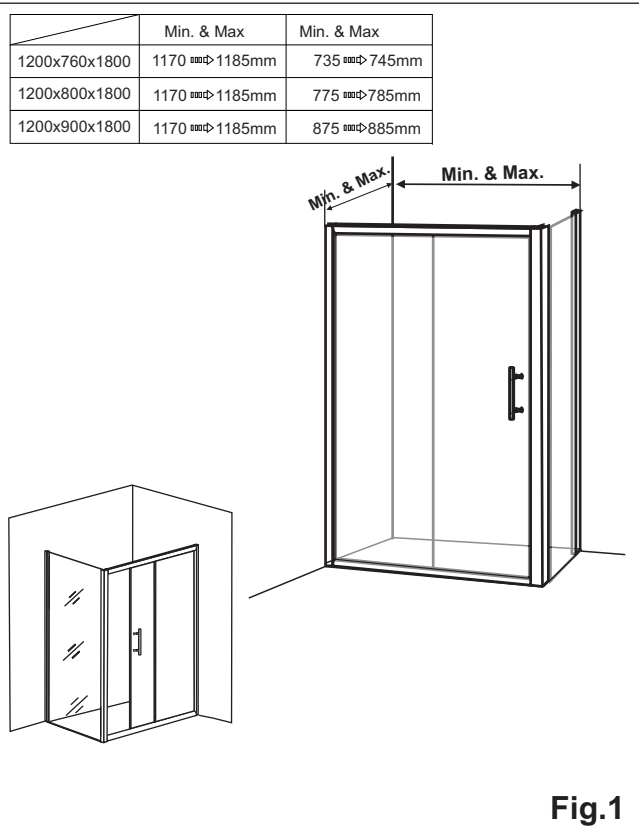

2. Push the splash seals(M) onto the top and bottom of the fixed glass panel(C) and trim to the correct lengths as illustrated in **Fig.2**.

Note: Ensure the taller side of the splash seal is fitted to the outside of the door.

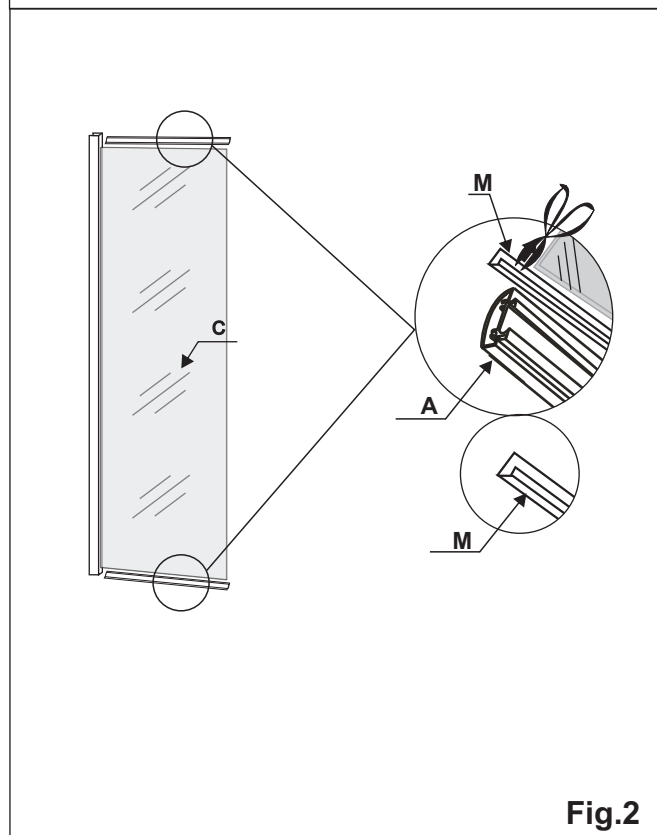



# Assembly Instructions

## Sliding Shower Enclosure

5. Insert the side profile of the fixed side panel(E) into the corner profile (G) and push it fully home, noting the correct orientation as per Fig.5.

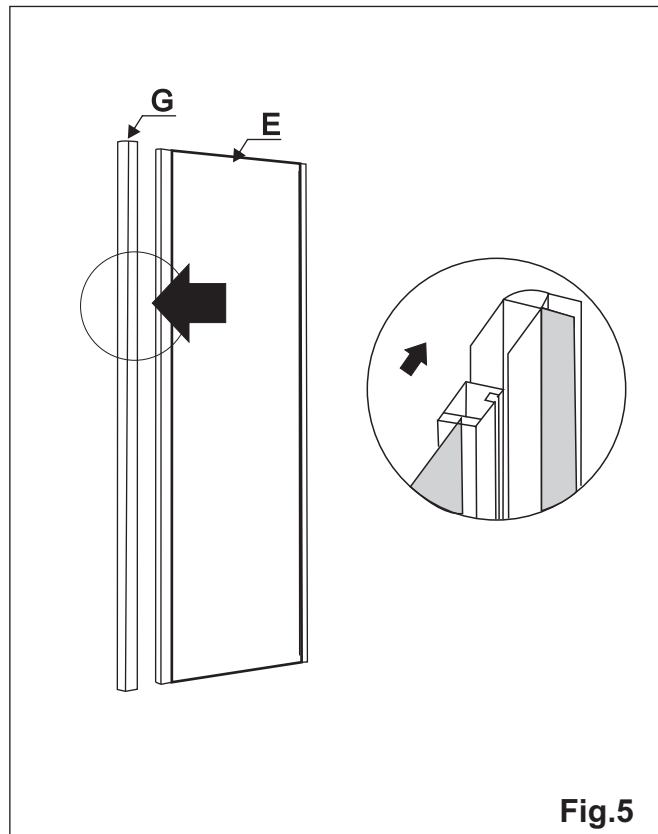

6a. Taking care not to move the profile, use a 3mm HSS drill to drill holes on the corner profile(G). Ensure that you do not drill too far and mark the outer surface of the profile on the fixed side panel(E).

6b. Secure the corner profile to the fixed side panel using screws ST4\*10mm(H2) and screw cap washers. Cover with screw caps. See Fig. 6.

**CAUTION:**  
THE GLASS IS RETAINED IN THE PROFILES TO A DEPTH OF 10MM. Under no circumstance should it be attempted to drill through the profiles in this region. Damage to the glass and injury may occur.

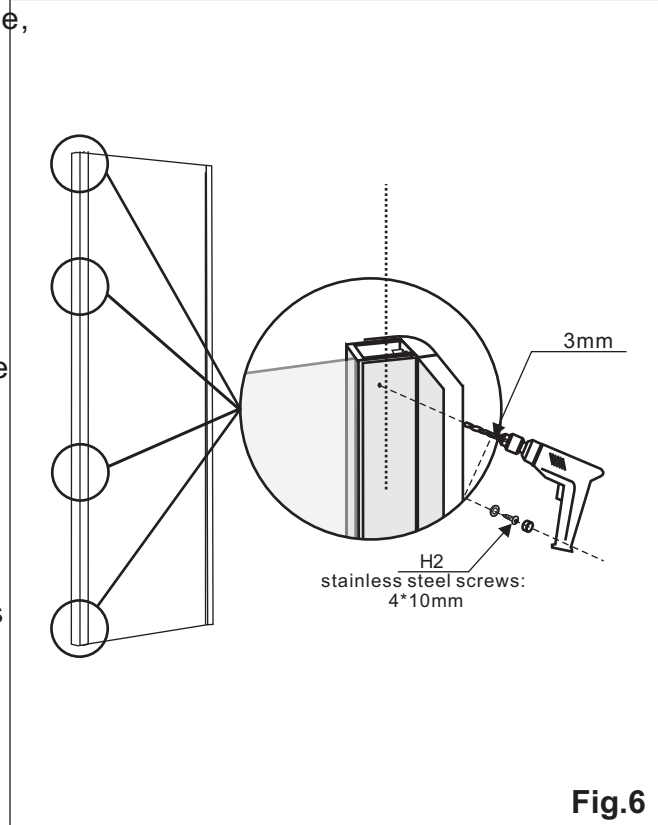

# Assembly Instructions

## Sliding Shower Enclosure

7a. Push the sliding glass profile(H) with magnetic strip over the other side of the corner profile(G) and push it fully home. See **Fig.7**.

7b. Taking care not to move the profile, use a 3mm HSS drill to drill holes on the sliding glass profile(H). Ensure that you do not drill too far and mark the outer surface of the profile on the door panel. See **Fig.7**.

7c. Secure the sliding glass profile (H) to the corner profile(G) using screws ST4\*10mm(H2) and screw cap washers. Cover with screw caps. See **Fig.7**.

**CAUTION:**  
THE GLASS IS RETAINED IN THE PROFILES TO A DEPTH OF 10MM. Under no circumstance should it be attempted to drill through the profiles in this region. Damage to the glass and injury may occur.

8a. Insert the F-shaped wall profile (B) into the side profile of sliding door. Ensure the correct orientation of the flange as per **Fig.8-1**.

8b. Push the U-shaped wall profile (B1) onto the side profile of the side panel (E) as per **Fig.8-2**.

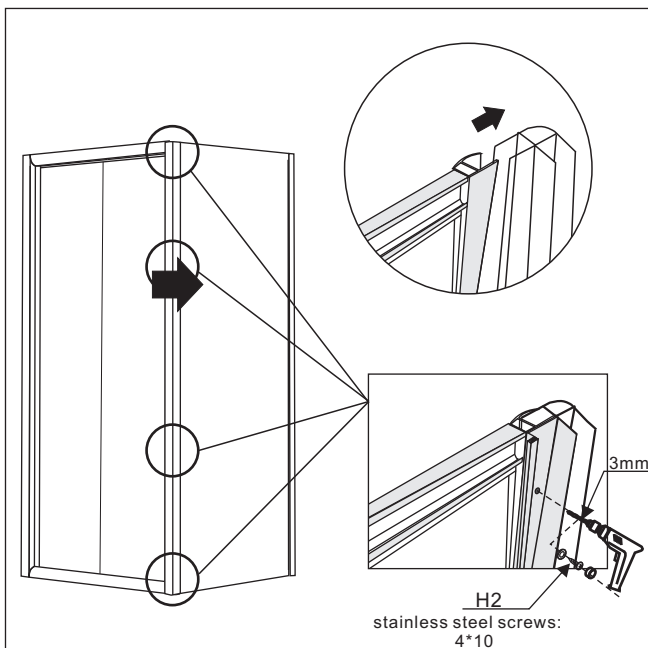

**Fig.7**

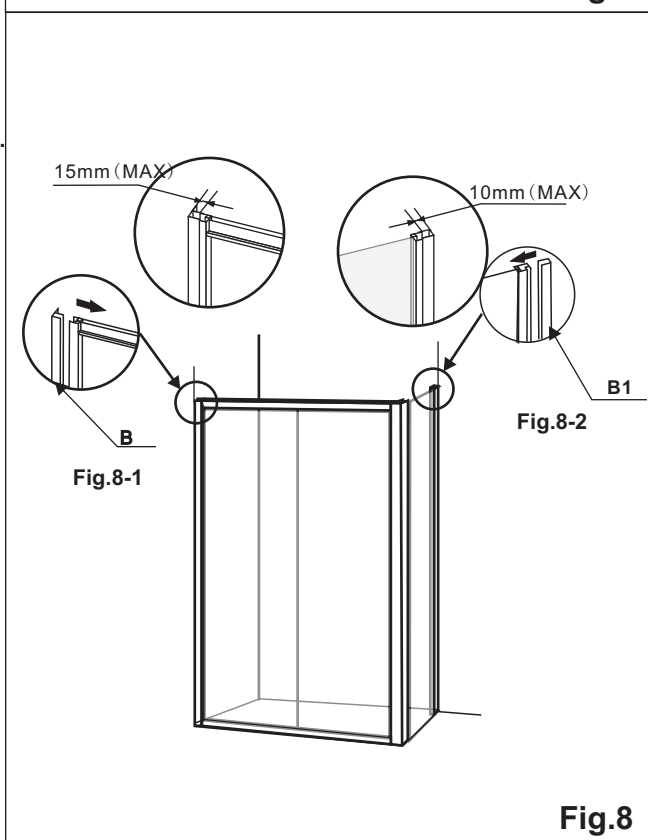

**Fig.8**

# Assembly Instructions

## Sliding Shower Enclosure

9a. Place the shower enclosure on the shower tray, and position it so that there is an even gap to the edge of the tray.

9b. Adjust the two wall profiles so that they sit flush to the walls, and use a spirit level to ensure that they are both vertical. See **Fig.9**.

9c. Taking care not to move the enclosure, mark the positions of the wall profiles on the wall with a pencil as per **Fig.9**.

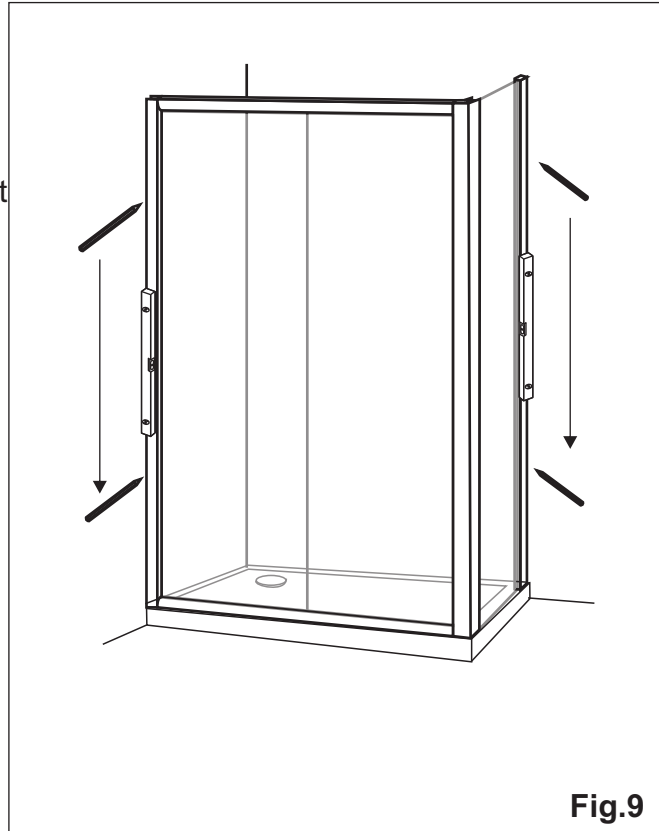

10a. Taking care not to move the enclosure, use the pre-drilled holes in the F-shaped wall profile(B) as a template and mark the hole positions on the wall with a pencil. See **Fig. 10**.

10b. Remove the enclosure and drill holes with a drill bit suitable for the wall type and fixing being used. Insert the wall plugs(12) into the holes using a rubber mallet.

10c. Apply silicone sealant to the back of the F-shaped wall profile(B) and secure it to the wall using plastic screw washers and screws ST4\*25mm(F2). Cover them with screw covers as per **Fig.10**.

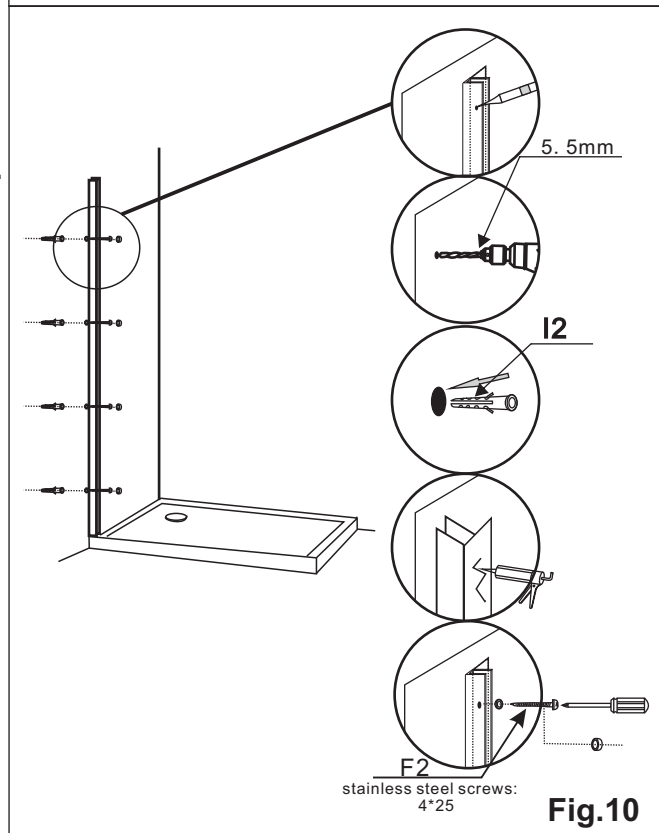



# Assembly Instructions

## Sliding Shower Enclosure

11a. Place the U-shaped wall profile (B1) back to the marked area. Use the pre-drilled holes in the wall profile (B1) as a template and mark the hole positions on the wall with a pencil.

11b. Remove the wall profile. Drill the holes with a drill bit suitable for the wall type and fixing being used. Insert the wall plugs (I2) into the holes using a rubber mallet.

11c. Apply silicone sealant to the back of the U-shaped wall profile (B1) and secure it to the wall using screw ST4x25mm as per **Fig.8**.

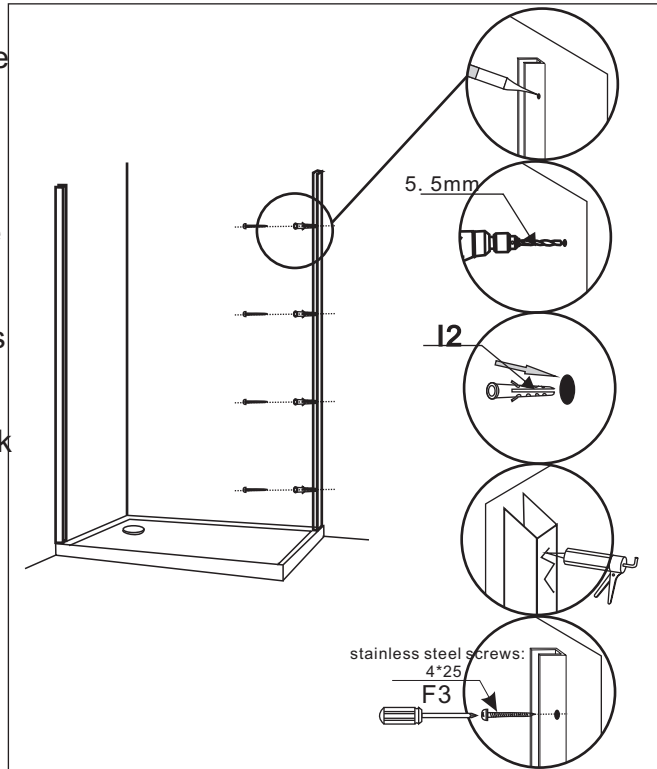

**Fig.11**

12a. Whilst supporting the frame, carefully insert one corner of the enclosure over the F-shaped wall profile (B) and push it fully home.

12b. Carefully fit the other bottom corner and fit it into the U-shaped wall profile (B1) and push it fully home. See **Fig. 12**.

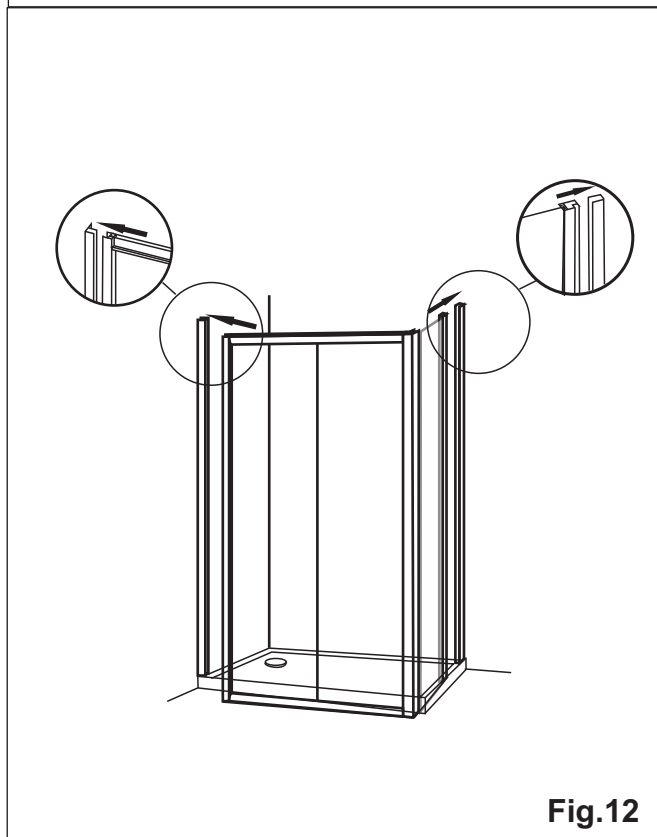

**Fig.12**

# Assembly Instructions

## Sliding Shower Enclosure

---

13. Fit the door handle(A2) onto the sliding door(D). Note that the rubber washers should be on both sides of the glass as per **Fig. 13**.

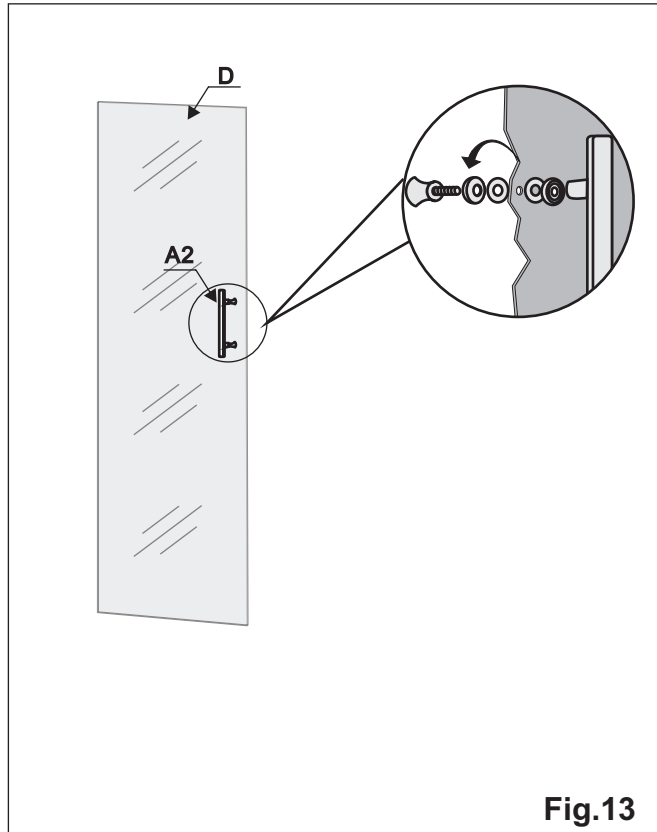

14. Fit the rollers(B2 & C2) onto the sliding door(D).  
Make sure the correct rollers are fitted to the top and bottom of the door.  
Please note that a rubber washer (M3) should be fitted between the door roller and the glass.  
Secure the rollers on the door using a cross-headed screwdriver.  
Push the cover caps over the screws on the rollers. See **Fig.14**.

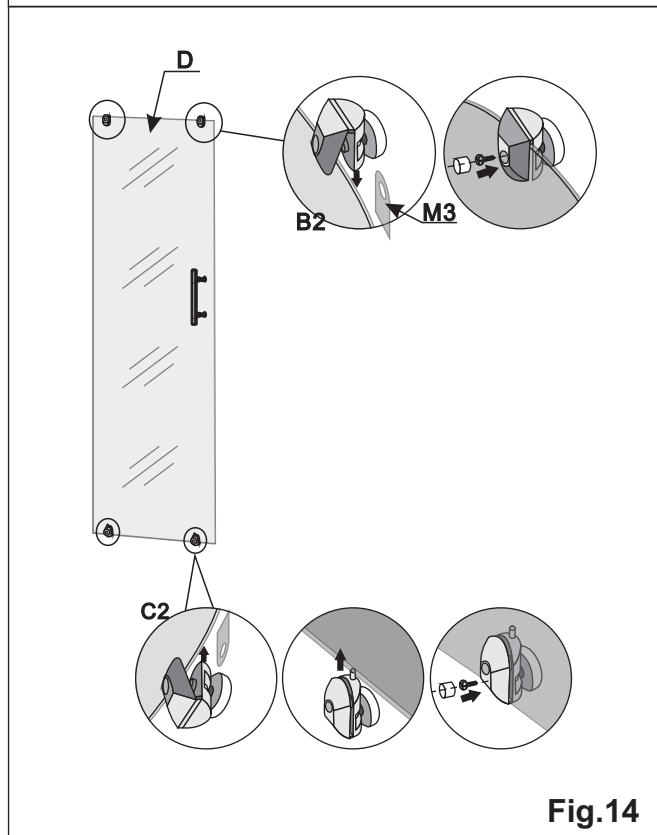

# Assembly Instructions

## Sliding Shower Enclosure

15. Cut the magnetic seal(I) to a suitable length and push onto the side of the sliding door(D) as per Fig. 15.

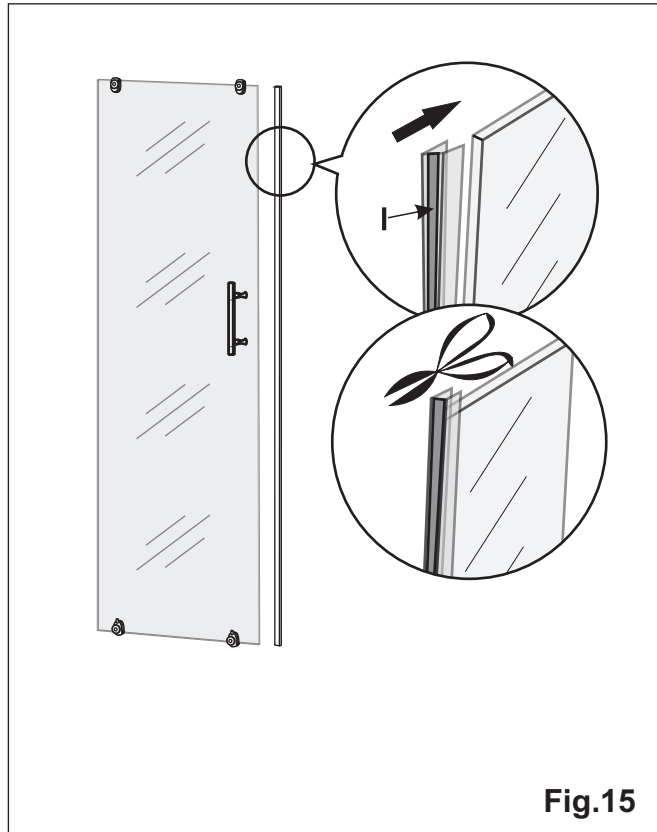

16a. Tilt the bottom of the door(D) into the enclosure, and locate the top rollers(B2) in the channel in the top track frame(A).

16b. Push down on the bottom rollers and locate them into the channel in the bottom track frame(A).

16c. To ensure that the sliding door(D) is hanging vertically and runs smoothly, adjust the top rollers(B2) by rotating the screw thread at the bottom. Raise and lower the door on both top rollers as required to minimize the gap between the door and the sliding glass profile and make sure the door runs smoothly.

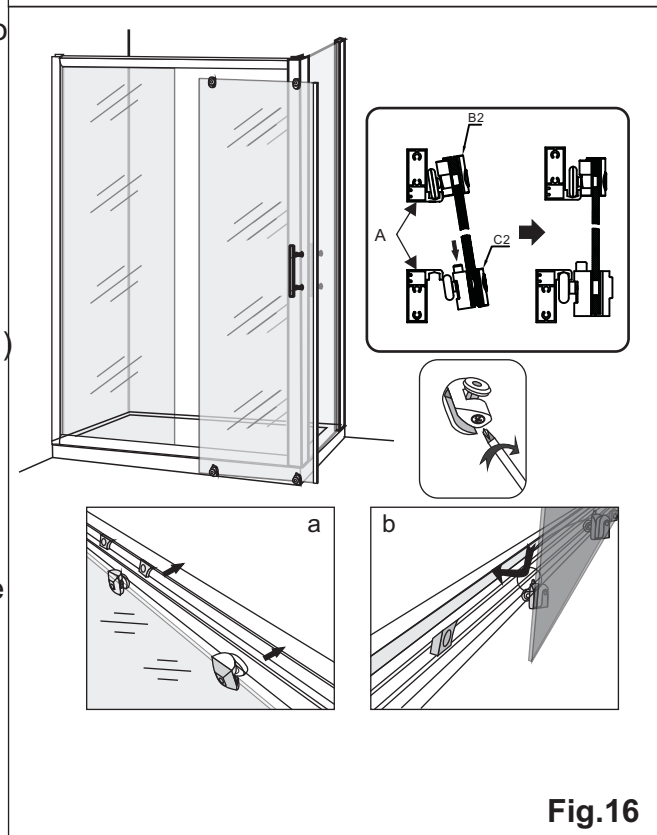

# Assembly Instructions

## Sliding Shower Enclosure

17. Push the vertical seals(F) onto the fixed door and sliding door, and cut them into suitable lengths as per Fig.17.

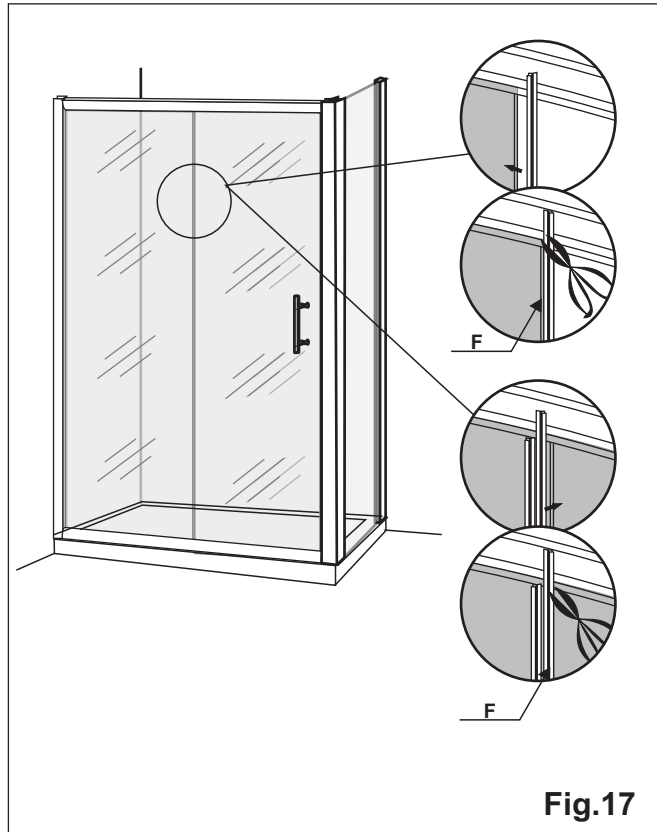

18a. Position the enclosure so that there is an even gap to the edge of the tray, and use a spirit level to ensure the side profiles are vertical.

18b. Taking care not to move the enclosure, use a 3mm HSS drill to drill holes on the side profile of the door panel(C) and the U-shaped wall profile(B1). Ensure that you do not drill too far and mark the outer surface of the profiles.

18c. Secure the profiles using screws ST4\*10mm(H2) and screw cap washers. Cover with screw caps. See Fig. 18.

**CAUTION:**  
THE GLASS IS RETAINED IN THE PROFILES TO A DEPTH OF 10MM. Under no circumstance should it be attempted to drill through the profiles in this region. Damage to the glass and injury may occur.

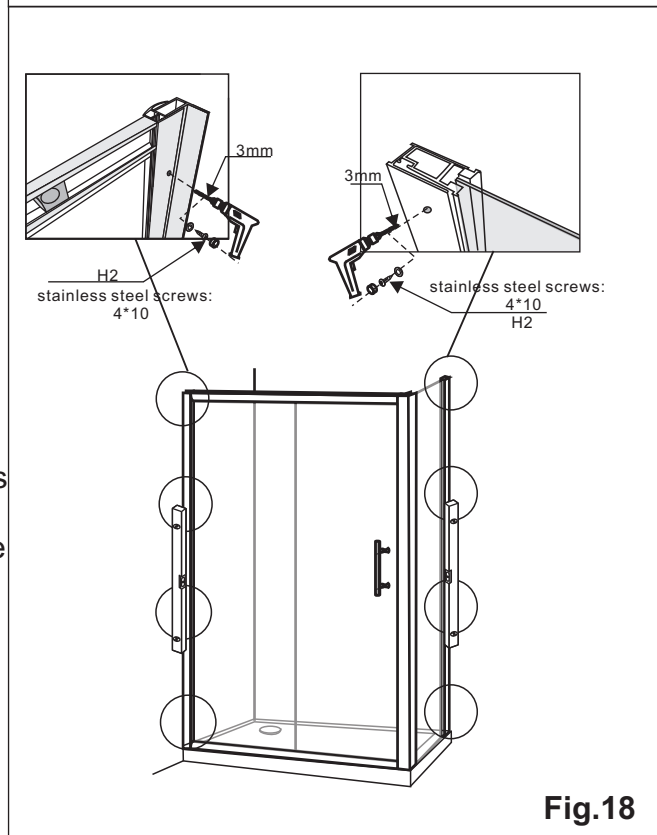

# Assembly Instructions

## Sliding Shower Enclosure

---

19. Apply silicone sealant to the joints on the outside of the shower enclosure only as indicated by the thick line in **Fig.19**.

Note: If silicone is applied to the inside of the enclosure as well, it can cause the water to remain trapped and build up, eventually causing leaks.

Note: Do not use the shower enclosure for at least 24 hours in order to allow the silicone sealant to cure fully.

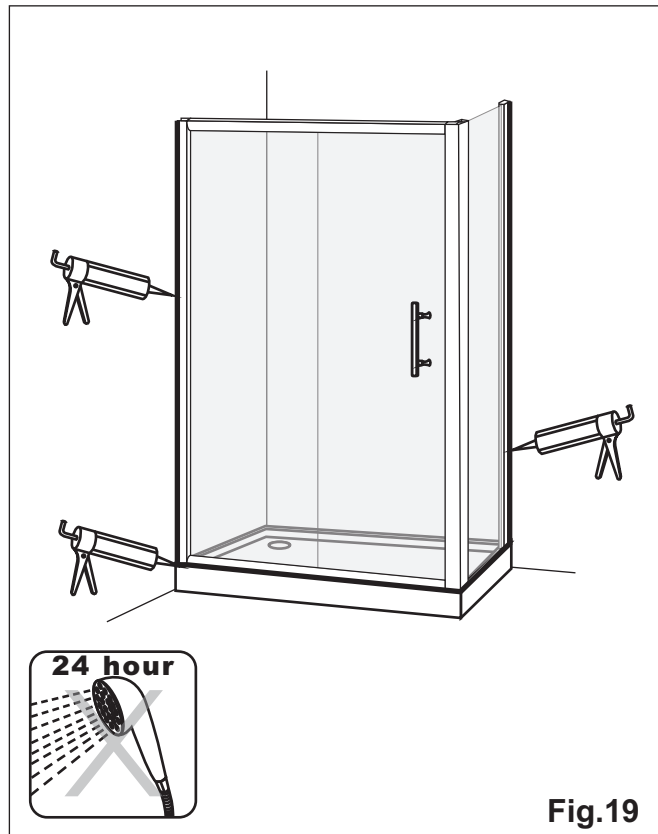

**Fig.19**

### Care & Use

---

- Soapy water is adequate to keep the glass clean, although glass cleaner can be used if required. Scourers, abrasives and chemical cleaners can damage the glass and pattern, and should not be used.
- In hard water areas, insoluble lime salts may be deposited on the glass. If this is allowed to build up it becomes increasingly difficult to remove and looks unsightly. Regular cleaning will minimize this effect.
- For further information, contact Customer Services (UK only) on 0845 313 0386.