

BI-FOLD ENCLOSURE INSTALLATION MANUAL

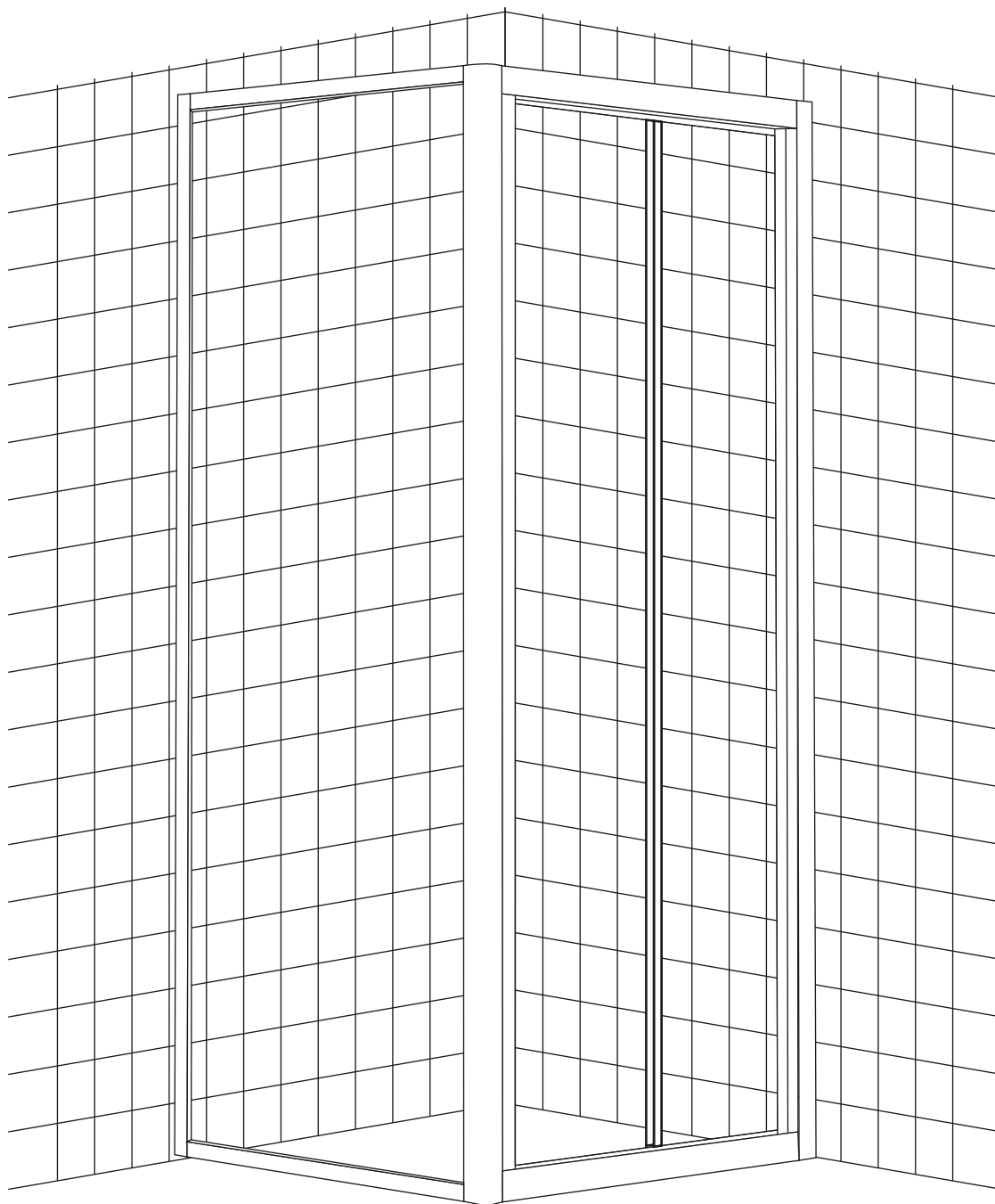

Product Reference (Barcode) :

MBIEB7602(5034109669443)

MBIEB8002(5034109669450)

MBIEB9002(5034109669467)

MBIED7602(5034109669528)

MBIED8012(5034109669535)

MBIED9004(5034109669542)

TABLE OF CONTENTS

Enclosure specification and contents	3
Tools Required (Not supplied)	4
Pre-installation and Technical Requirements	5
Important Safety Notes and Aftercare Instructions	5
Wall Profile Assembly(Bi-fold Door)	6
Fixed Bi-fold Door Assembly (Bi-fold Door)	7
Fixed Bi-fold Door Assembly(Bi-fold Enclosure)	8
Fixed Side Panel Assembly(Bi-fold Enclosure)	9
Wall Profile Assembly(Bi-fold Enclosure)	10-11
Apply Silicone Sealant (Bi-fold Enclosure)	12

Enclosure Specification and Contents

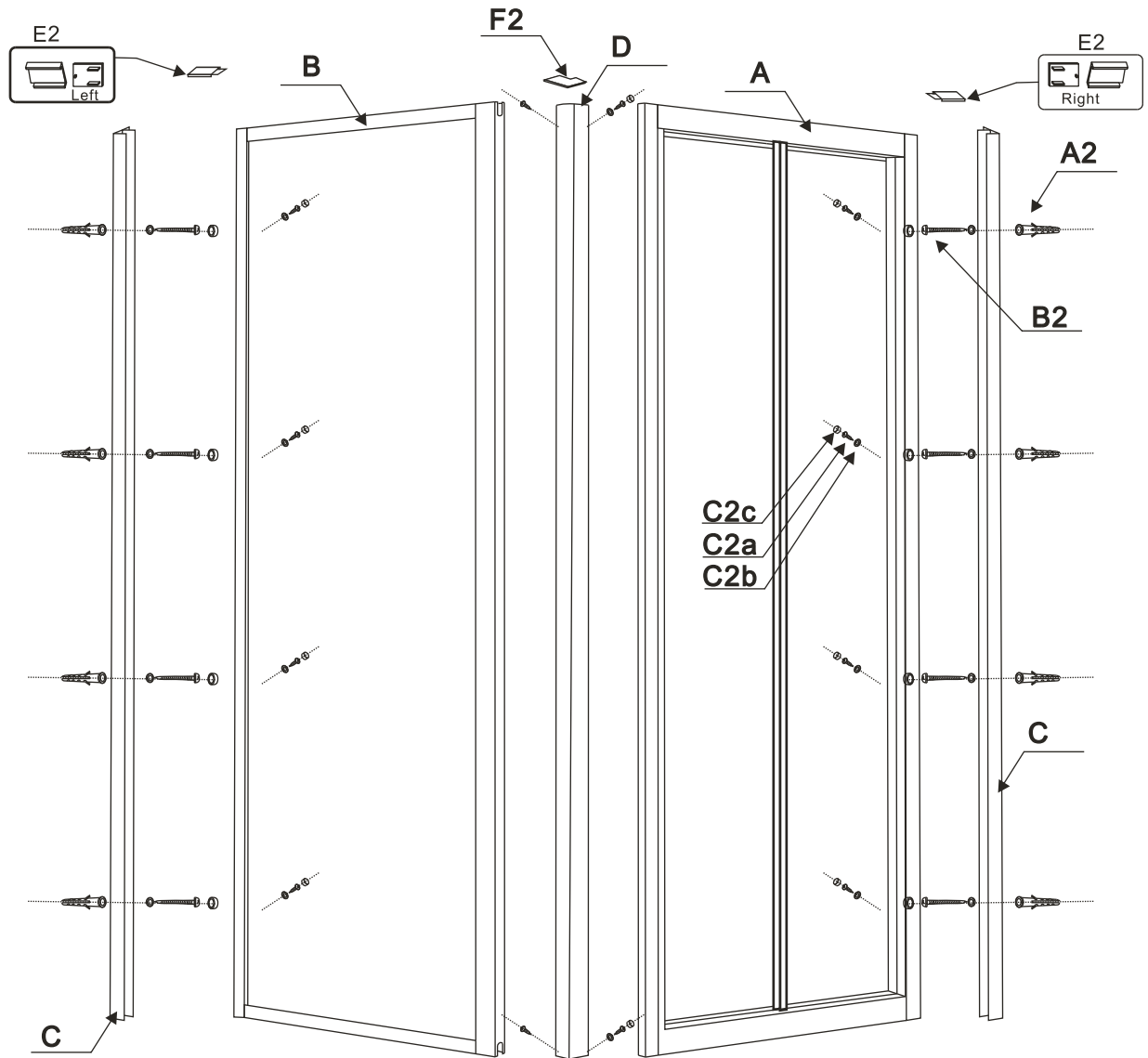

Ref	Description	Qty
A	BI-FOLD DOOR	1
* B	SIDE PANEL	1
C	WALL PROFILE	2
* D	CORNER PROFILE	1

NOTE: THE ITEMS MARKED WITH AN ASTERISK "*" ARE SUPPLIED WITHIN THE SIDE PANEL PACK (PURCHASED SEPARATELY)

Fixing kit includes

Ref	Description	Illustration	Qty
A2	expandable wall plug		8
B2	stainless steel screws: 4*25		8
C2a	stainless steel screws: 4*10		8
C2b	plastic screw washer		8
C2c	screw cover		8
* C2a	stainless steel screws: 4*10		4
* C2b	plastic screw washer		2
* C2c	screw cover		2
D2	Drill bit 3mm		1
E2	profile cap		1
* F2	corner profile cap		1
G2	Wheel cap		1

Tools Required(Not Supplied)

TOOLS REQUIRED(NOT SUPPLIED)

When you're ready to start, make sure that you have the parts listed and the following tools to hand, plenty of space and a clean dry area for assembly.

Two people are needed. Please note : although these instructions are comprehensive,we always recommend that a technically competent installer should undertake installation.

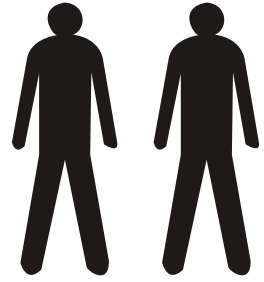

**Drill Bit to suit wall construction
6 mm**

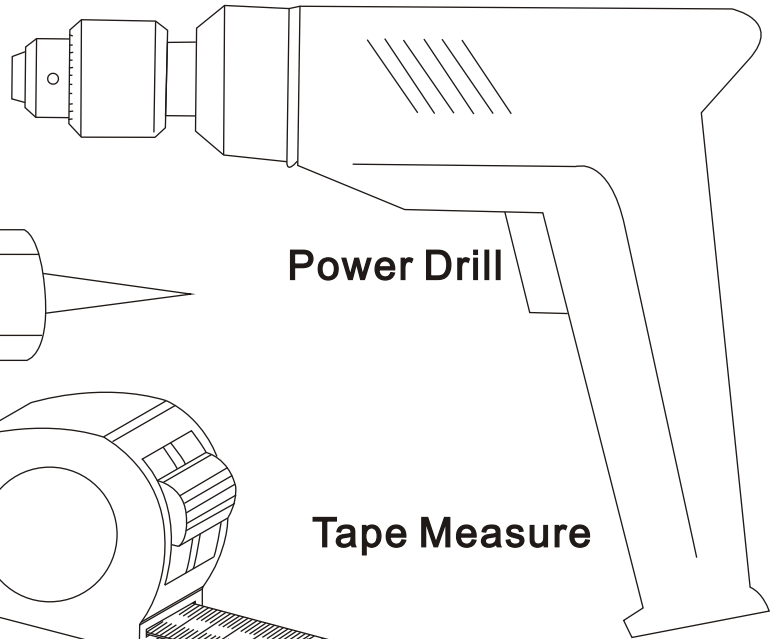

Power Drill

Sanitary Silicone

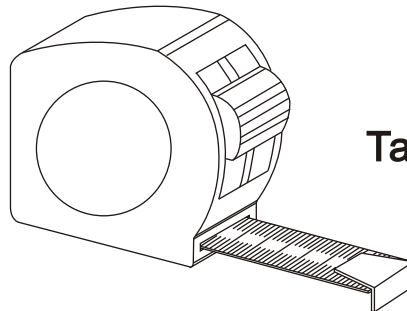
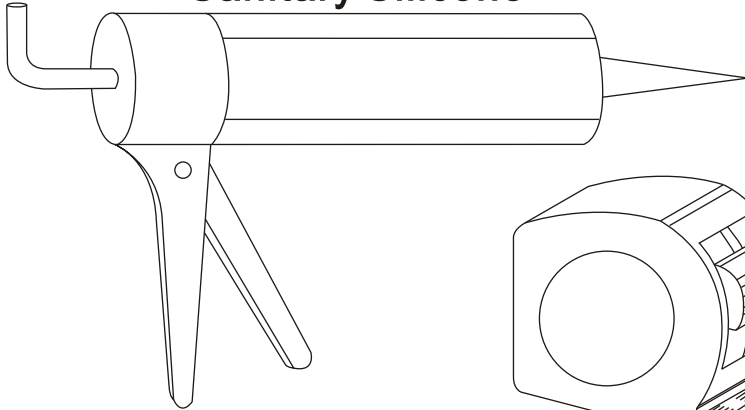

Tape Measure

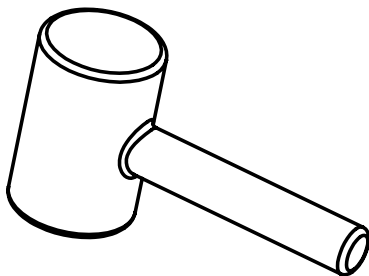

Rubber Mallet

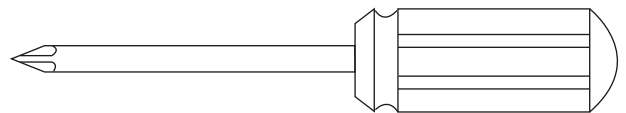

Magnetic Crosshead Screwdriver



Pencil

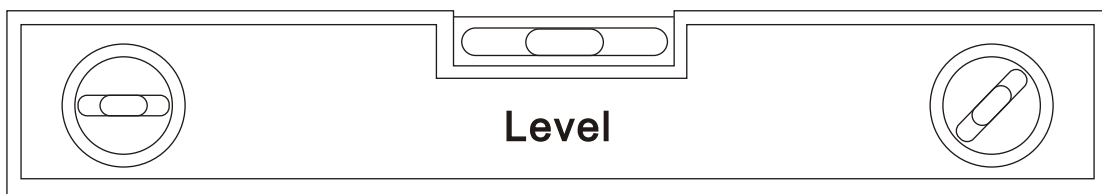

Level

PRE-INSTALLATION AND TECHNICAL REQUIREMENTS

- All dimensions are shown in millimeters, except where otherwise indicated.
- Ensure that the enclosure set is fitted to a level floor and vertical wall surface
- This instruction manual is applicable for both pre-tiled wall and plain walls.
10mm distance is reserved for tiling of plain walls..

Please note: The wall fixings included with this product are suitable for solid walls only. Plasterboard or stud walls may require specialist fixings (not supplied).

Due to the possibility of residual spray, the area around the outside of the shower tray should be tiled, or made otherwise water resistant.

IMPORTANT SAFETY NOTES

- THE GLASS IS RETAINED IN THE PROFILES TO A DEPTH OF 10MM.
under no circumstance should it be attempted to drill through the profiles in this region.
Damage to the glass and injury may occur
- Please handle all glass with care, avoiding knocks and shock loading to all sides and edges.
Safety glass cannot be reworked.
- Care should be taken when drilling into walls to avoid hidden pipes or electrical cables.

AFTERCARE INSTRUCTIONS

- Soap and water will be adequate to clean the glass – a glass cleaner can be used if required.
- In hard water districts, insoluble lime salts may be deposited on the glass. If this deposit is allowed to build up it becomes increasingly difficult to remove and looks unsightly. Regular cleaning will minimise this effect.

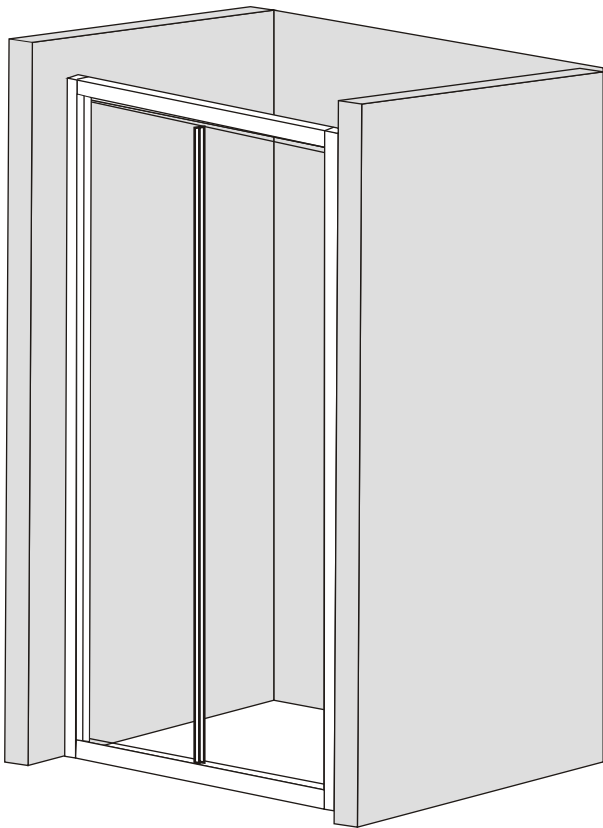

BI-FOLD DOOR

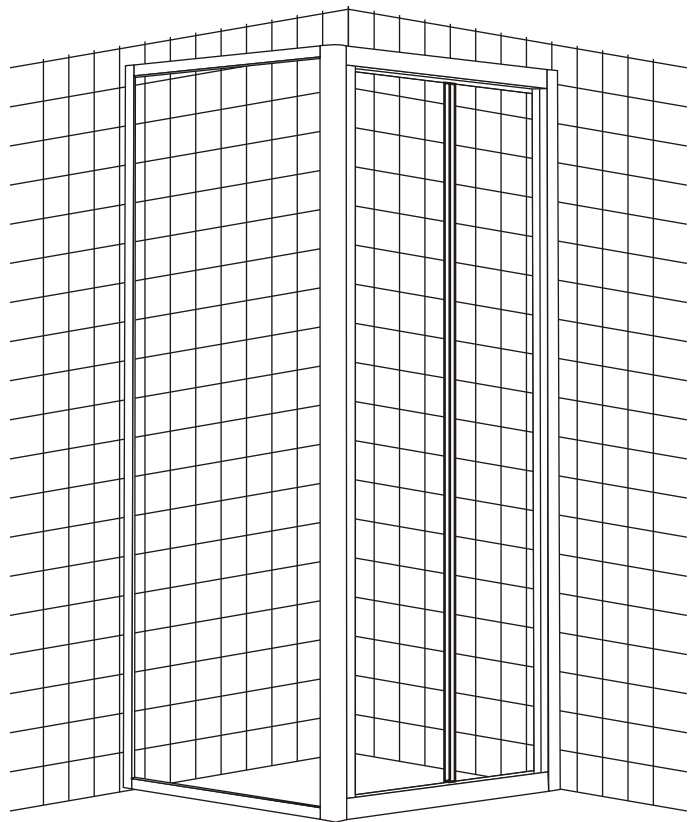

BI-FOLD ENCLOSURE

BI-FOLD DOOR

Wall Profile Assembly

- Push the wall profiles (C) onto the bifold door (A), place the bifold door in position, adjust the wall profiles until they touch the walls, mark the position of the profiles on the wall
- Remove the bifold door, place the wall profiles back in position, mark the position of the fixing holes

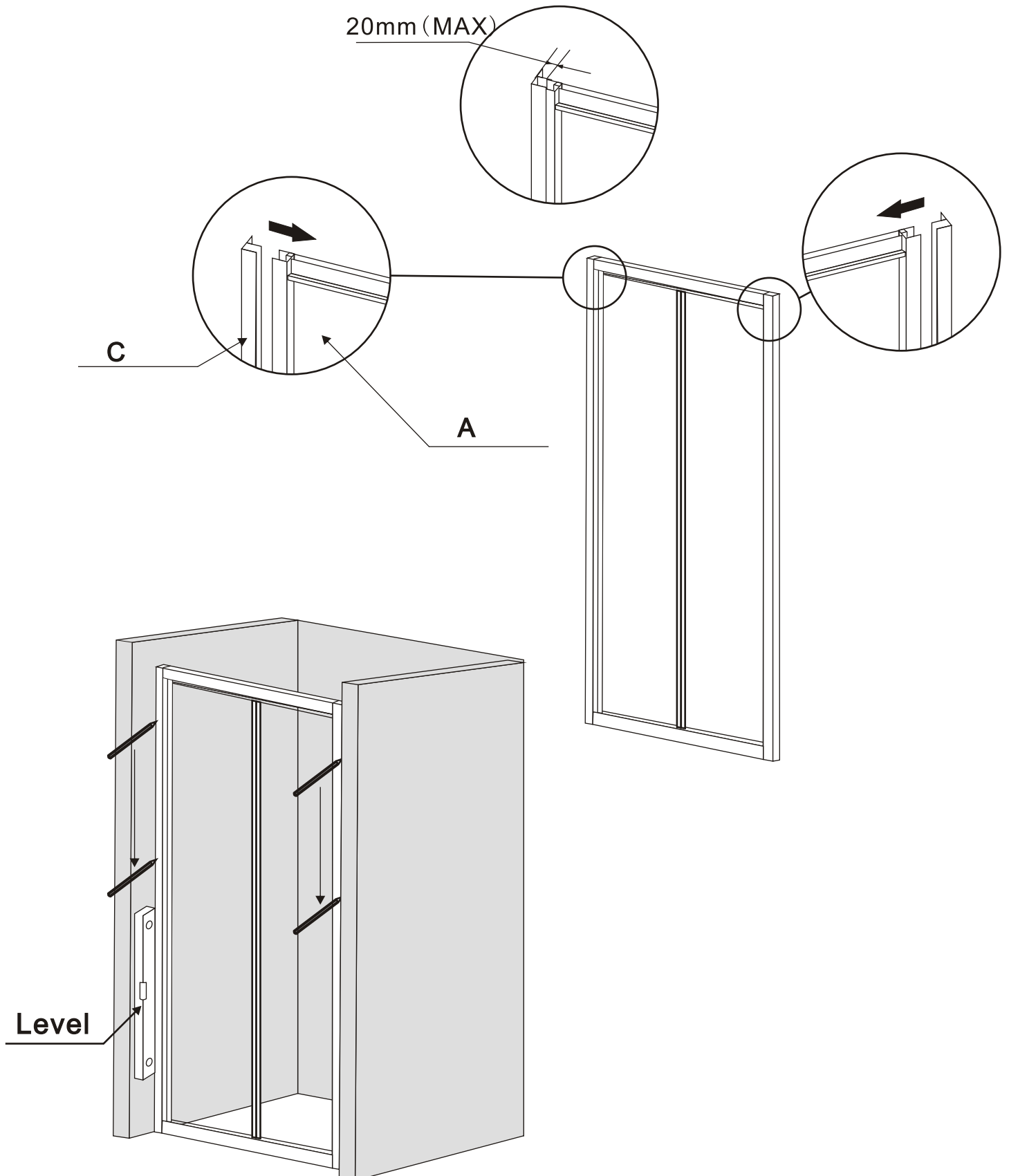

BI-FOLD DOOR

Fixed Bi-fold Door Assembly

- Drill the holes in the wall with $\text{\O}6\text{mm}$ drill bit in 35mm depth.
Use rubber mallet to insert wall plugs (A2) into the holes.
- Push the wall profiles back onto the bifold door, then line-up the holes in the wall profiles with the holes drilled in the wall
- Secure the profiles to the wall with the screws ST4x25 and plastic screw washers (B2), clip the screw covers on.
- Using the 3mm drill bit (D2) drill through the profiles from inside the enclosure (see diagram below). Do not drill through the front of the profiles. Secure the pivot door to the profiles using the screws (C2a) and screw washers (C2b).
Clip the screw covers (C2c) onto the screw washers
- Clip profile caps (E2) on
- Apply silicone sealant to all joints between wall profiles and tray.
- Do not use the enclosure for 24 hours, to allow the silicone to dry completely.

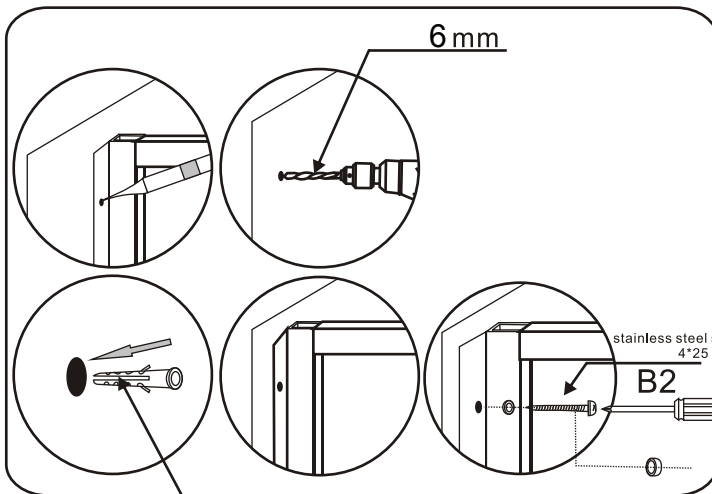

A2

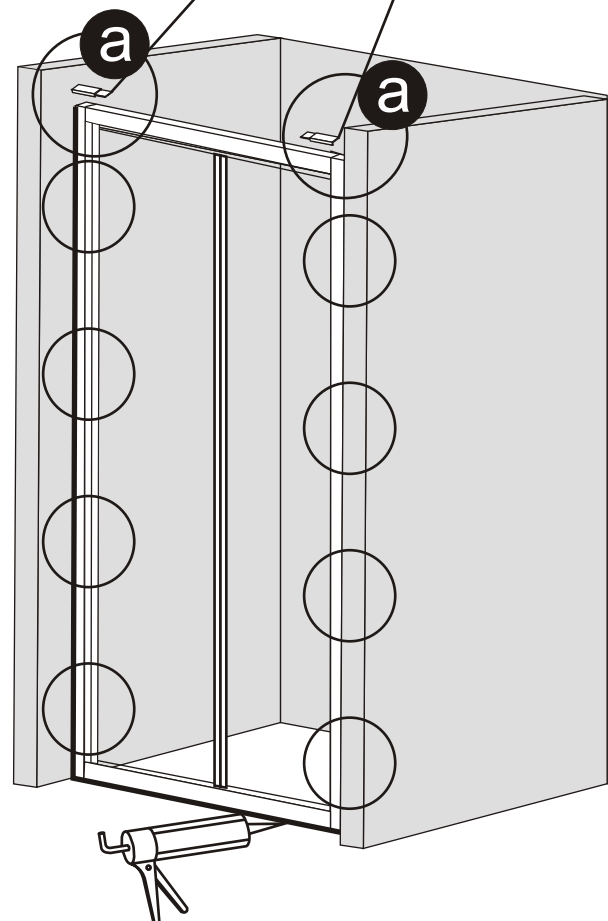
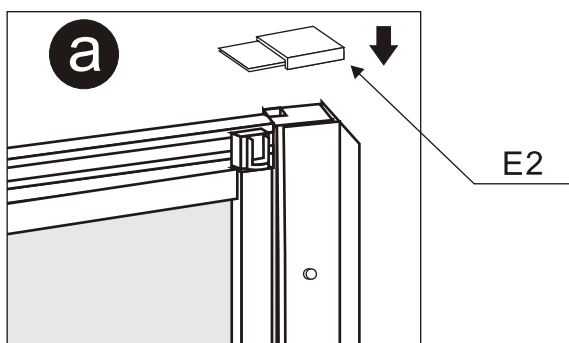
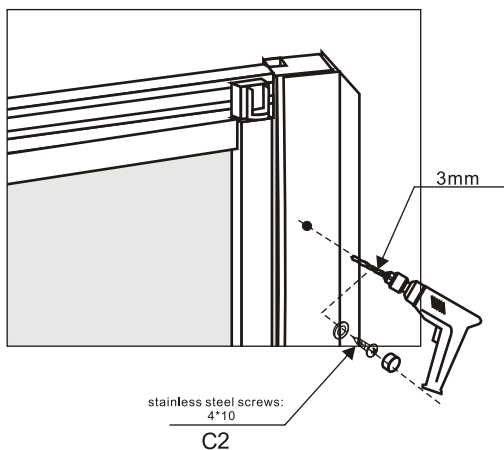
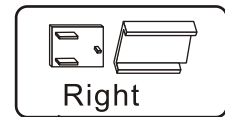
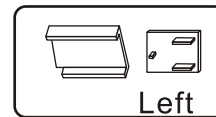

BI-FOLD ENCLOSURE

Fixed Bi-fold Door Assembly

- Fit the shower tray in the required position, in accordance with the instructions provided with it.
If the shower tray is not needed, please choose a suitable flooring area, where you want the enclosure to be.
- Insert the corner profile(D) onto the fixed Bi-fold door(A).
- Drill two holes with $\text{Ø}3\text{mm}$ bit in 5mm depth through pre-drilled holes on corner profile .
Do not drill through the profiles, otherwise it will damage the profile's surface.
- Fix with screws ST4x10 (C2a).

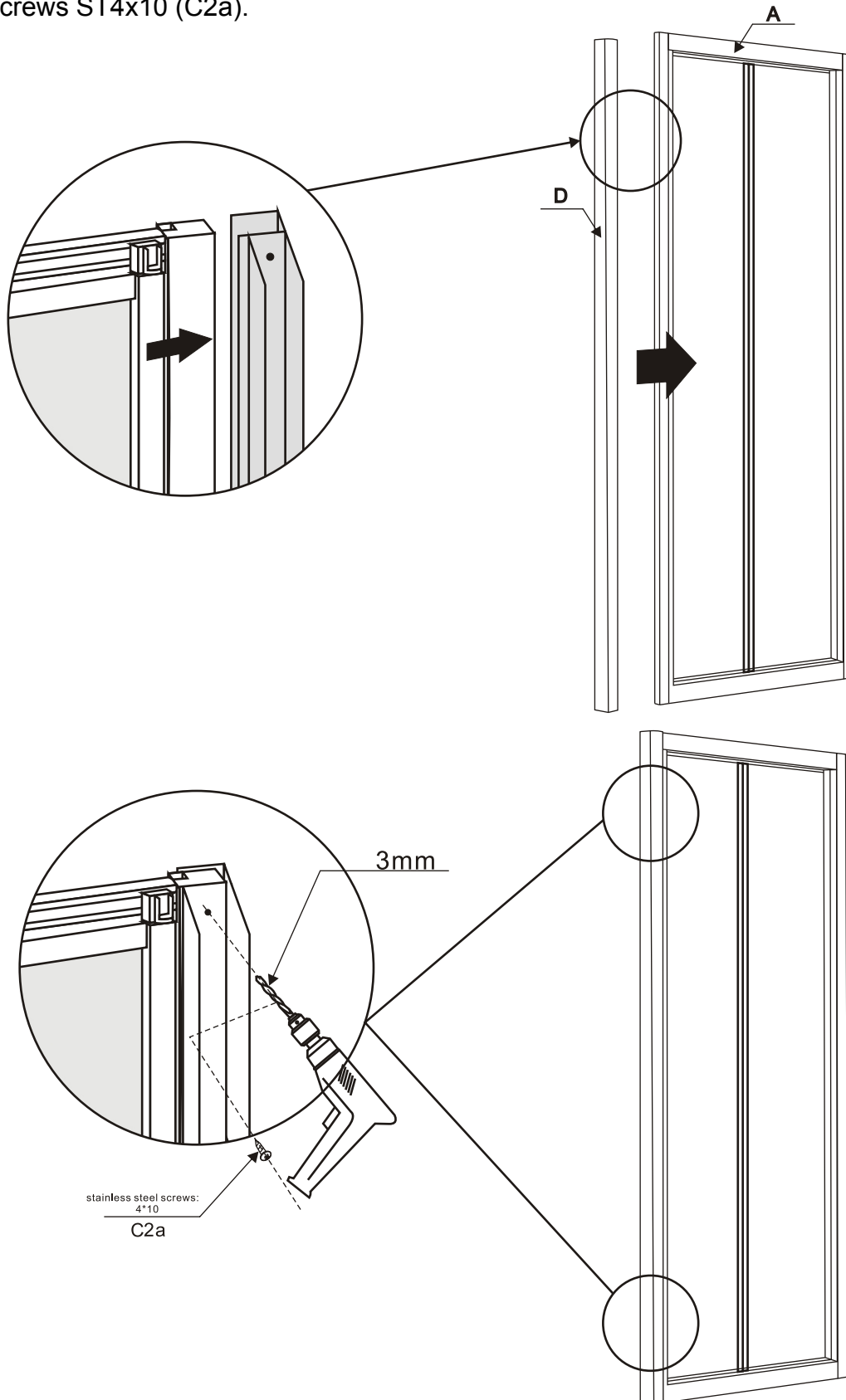

BI-FOLD ENCLOSURE

Fixed Side Panel Assembly

- The glass is retained in the profiles to a depth of 10mm. Do not attempt to drill through the profiles in this area.
- Push the side panel (B) into the corner profile (D). Using the 3mm drill bit (D2) drill a hole at the top and bottom of the corner profile to a depth of 5mm. Note that the holes should be drilled 25mm from the ends of the corner profile (see diagram below).
- Secure the side panel to the corner profile using screws ST4x10 (C2a) and screw washers (C2b). Clip the screw covers (C2c) onto the screw washers

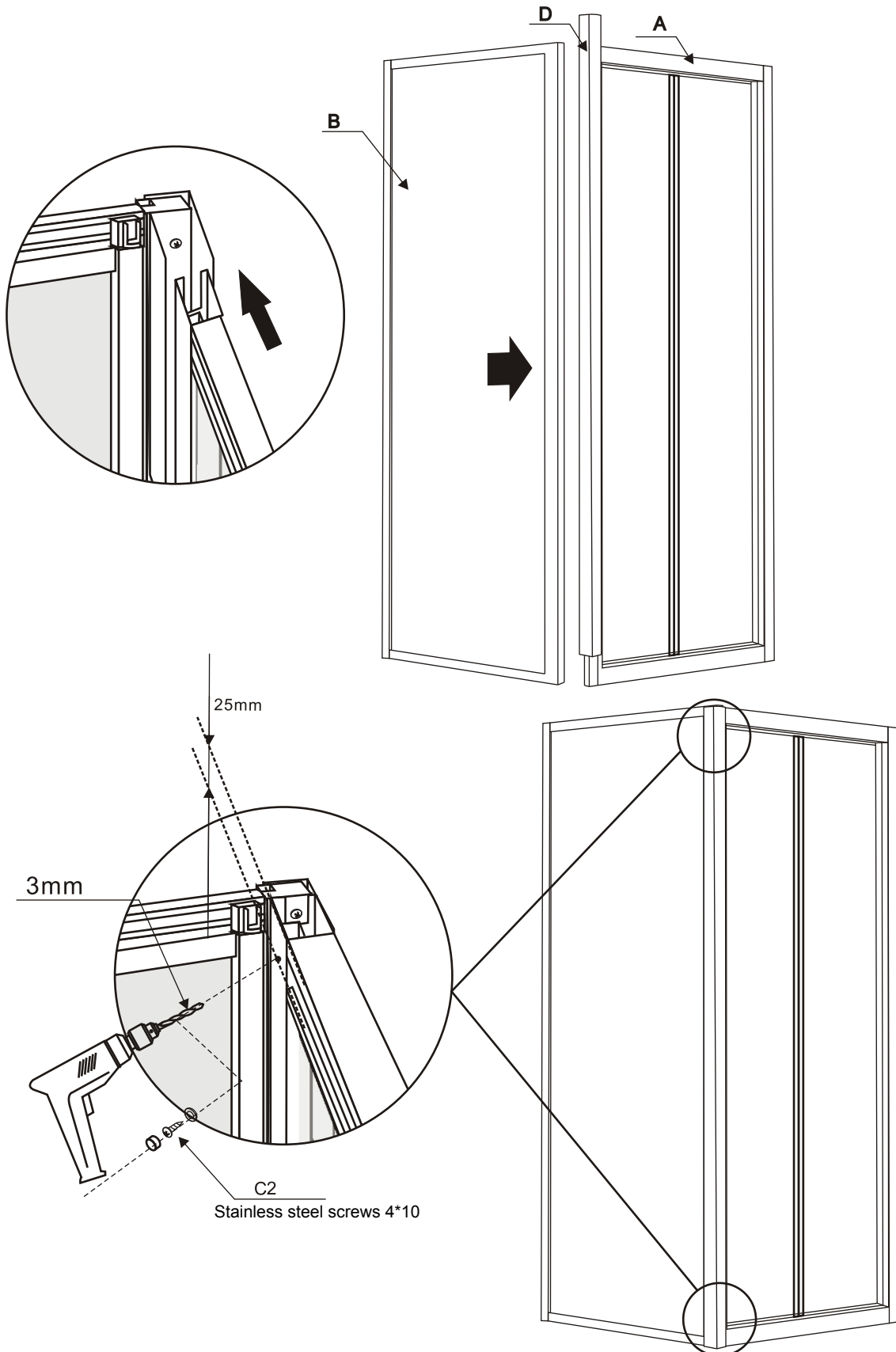

BI-FOLD ENCLOSURE

Wall profile Assembly

- Insert the wall profiles (C) onto the fixed Bi-fold door (A) and the fixed side panel (B).
- Place the fixed Bi-fold enclosure on the tray/floor.
Check with a spirit level and adjust the position until the bottom track is parallel on the shower tray/floor.
- Adjust the wall profiles until they are in contact with the walls. There is a maximum of 20mm adjustment for out-of-true walls.
- Using a pencil, mark the position of the wall profiles on the walls.
- Remove the fixed Bi-fold enclosure from the shower tray/floor.

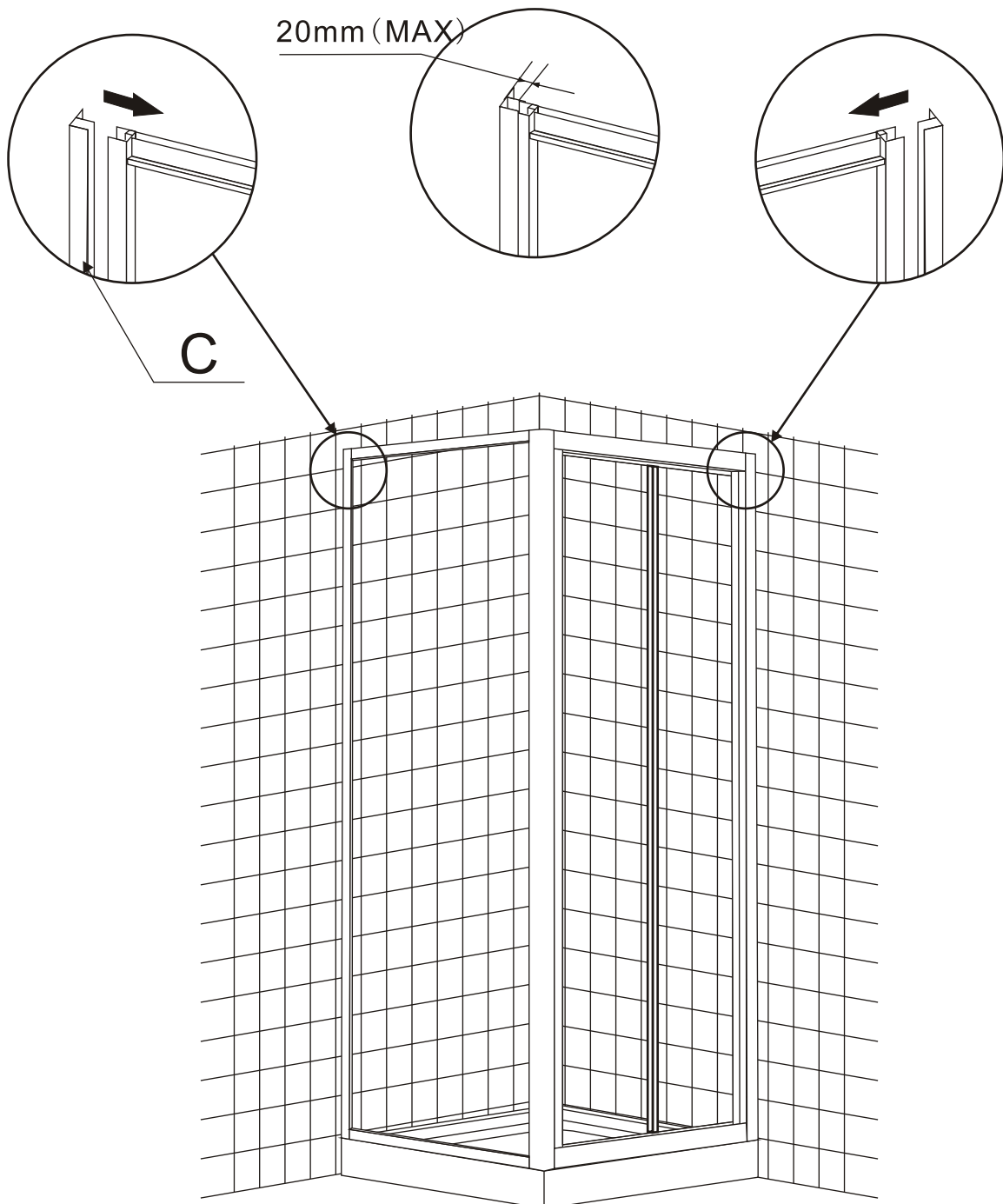

BI-FOLD ENCLOSURE

Wall Profile Assembly

- Place the wall profiles back to the marked area.
- Drill holes with Ø6mm drill bit in 35mm depth.
- Use rubber mallet to insert wall plugs (A2) into the holes.
- Fix wall profiles with the screws ST4x25 and plastic screw washers (B2), clip the screw covers on.
- Insert the fixed Bi-fold enclosure into the fixed wall profiles (C).
- Drill holes with Ø3mm drill bit in 5mm depth on wall profiles (C).
- Do not drill through the profiles, otherwise it will damage the profile's surface.
- Fix with the screws ST4x10 (C2a) and plastic screw washers (C2b), clip the screw covers (C2c) on.
- Clip profile caps (E2) on the fixed side panel and Bi-fold door.
- Clip corner profile cap (F2) and wheel cap (G2) on.

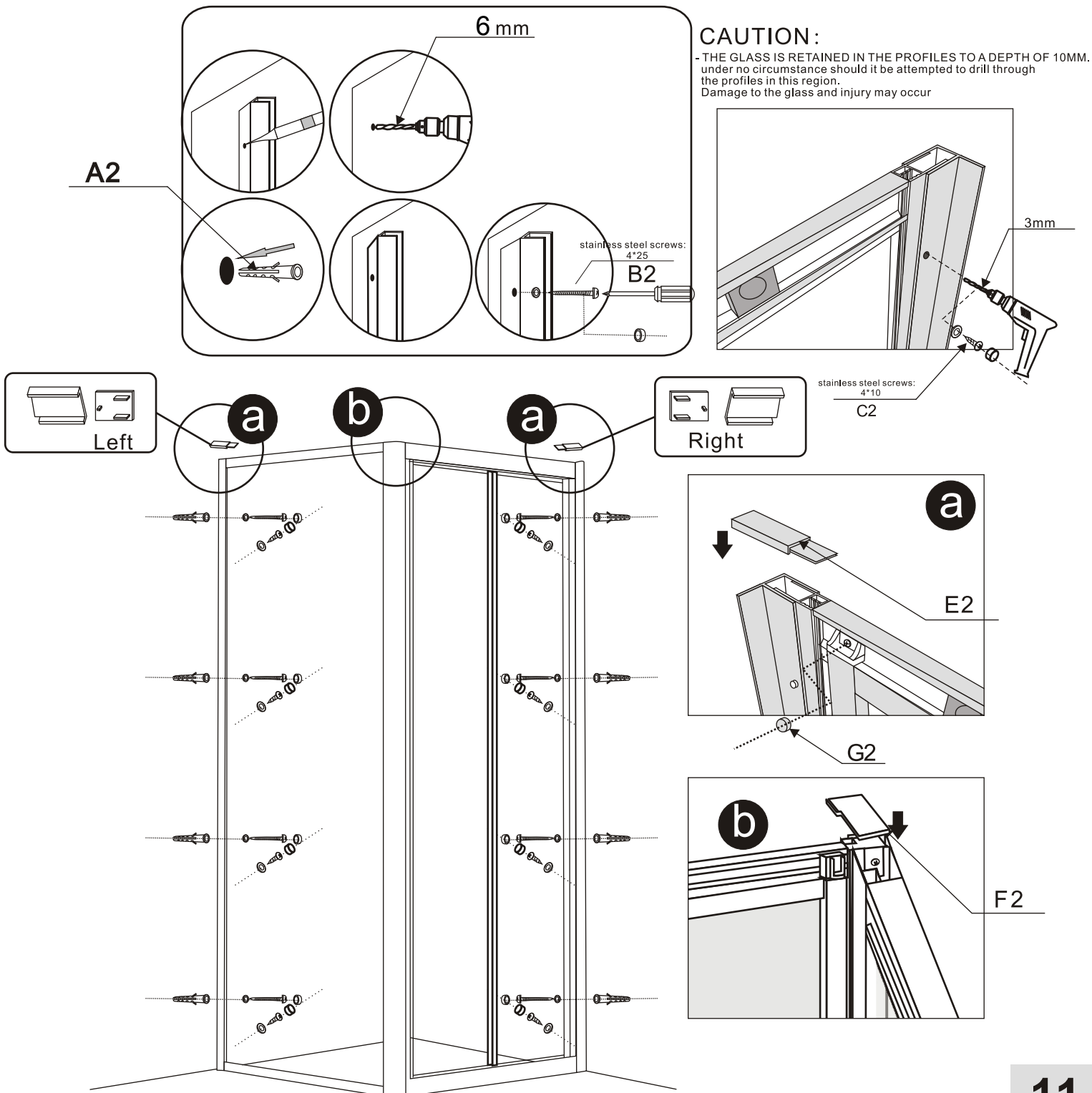

Apply Silicone Sealant

- Apply silicone sealant to all joints between wall profiles and tray.
- Do not use the enclosure for 24 hours, to allow the silicone to dry completely.

