

IN00355 (rev A)

Quadrant Enclosure

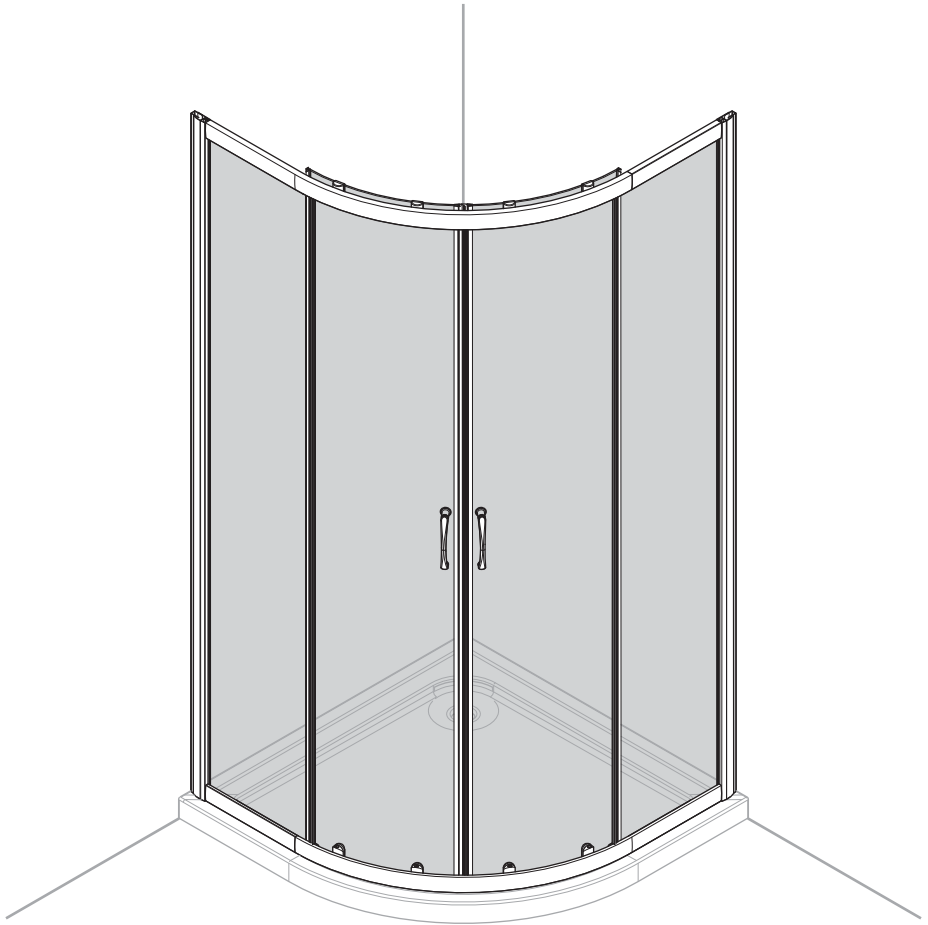

Before You Start

- Check that the tray has been installed correctly and that it is level (Fig. A), tiled down onto and sealed to the manufacturer's guidelines. **Please Note:** All product supplied without tray.
- Ensure the product is fitted to a non-porous surface ie. tiled. Check that the wall surface is flat.
- Unpack and check the product is complete and undamaged.
- Fixings are supplied for solid walls only. Ensure that the correct fixings are used for the wall type – if in doubt seek professional advice.
- Ensure the area is clean, dry and dust free.
- Read the instructions in full.
- Have the correct tools available, (as shown below, see 'Tools Required').

Fig.A.

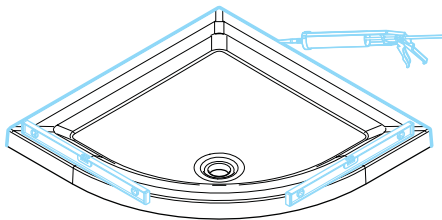

Safety

- Handle all glass with care - support on cardboard to avoid risk of breakage.
- This product is heavy and requires 2 people to carry and install it.
- When drilling walls check first for hidden pipes and cables.
- All glass is toughened – it cannot be reworked or replaced by ordinary glass.
- Use safety eyewear when drilling.
- Use safety eyewear when handling glass.
- Keep all small parts away from children.

Disclaimer

- Please notify the retailer immediately of any damage or faults. The manufacturer cannot be held responsible for any installation costs that may arise from damaged or faulty product being installed.
- Please dispose of all packaging with due regard to the environment.

Tools Required (not supplied)

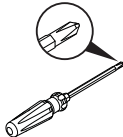
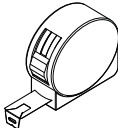
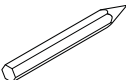
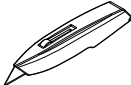
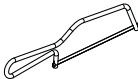
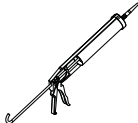
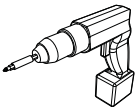
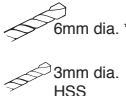
<p>Spirit Level</p> 	<p>Screwdriver</p> 	<p>Tape Measure</p> 	<p>Pencil</p> 	<p>Utility Knife</p> 
<p>Junior Hacksaw</p> 	<p>Silicone Gun & Sealant</p> 	<p>Power Drill</p> 	<p>Suitable Drill Bits</p>  <p>6mm dia. *</p> <p>3mm dia. HSS</p>	<p>* Ensure drill bit used is suitable for wall surface</p>



Help Line: 0870 241 6131

Lines open: 8.30am - 5.00pm Monday to Friday
Standard National call charge rate from BT landlines

Parts & Fittings Supplied



Please notify the retailer immediately of any damage or faults. The manufacturer cannot be held responsible for any installation costs that may arise from a damaged or faulty product being installed.



Keep small parts away from children

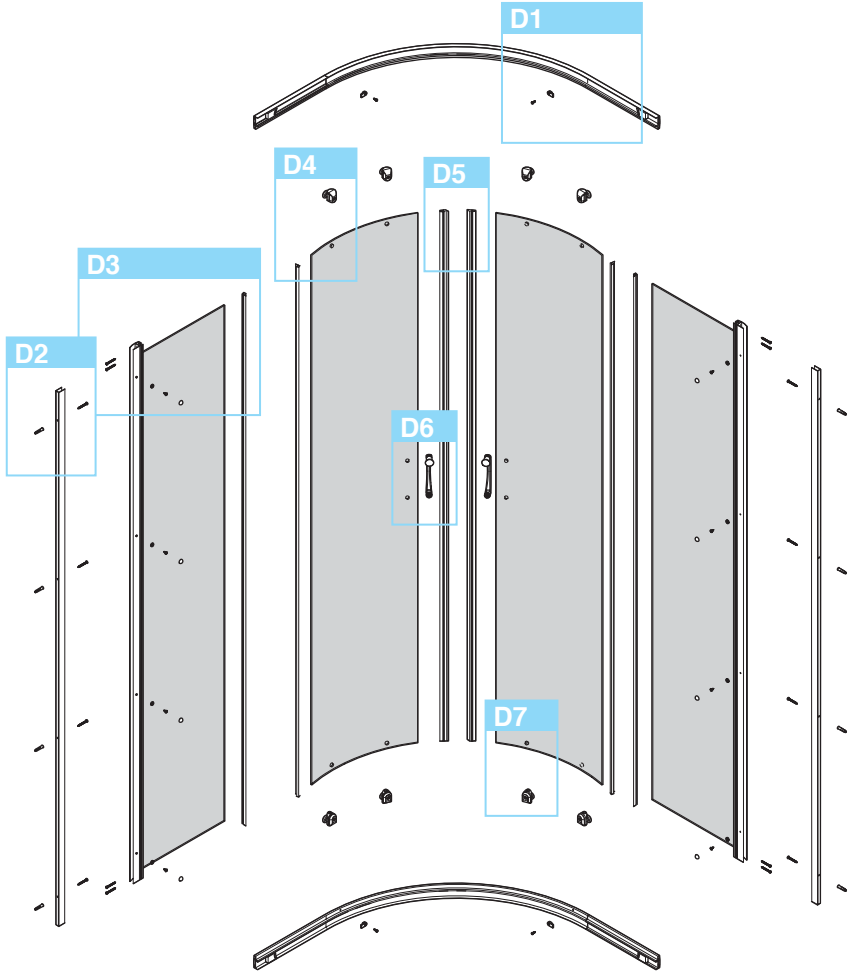

D1

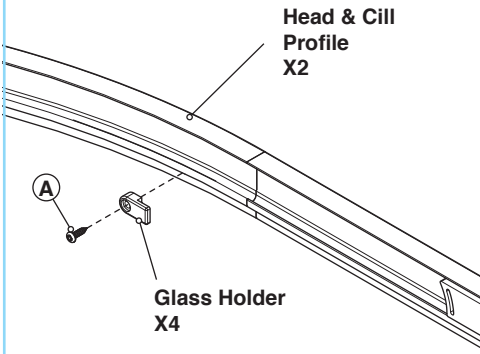

D2

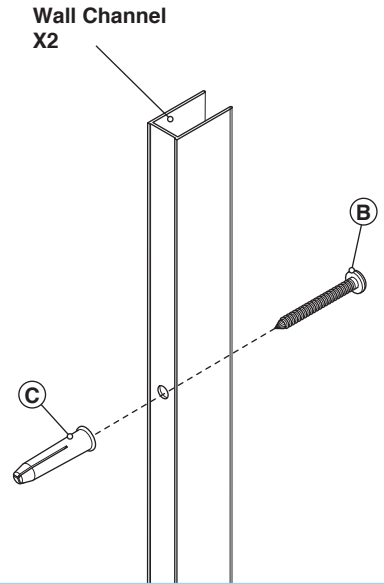

D3

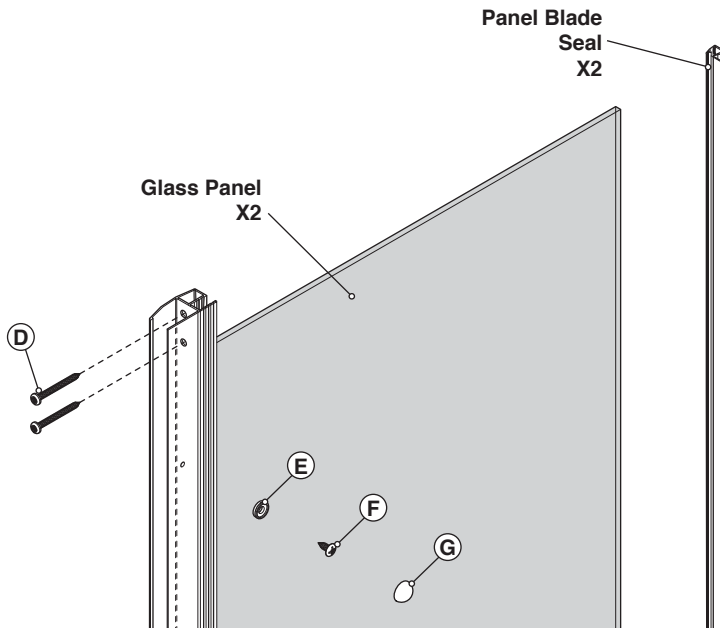

D4

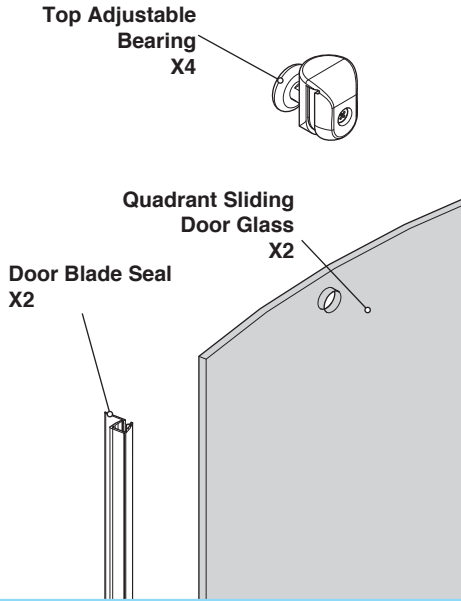

D5

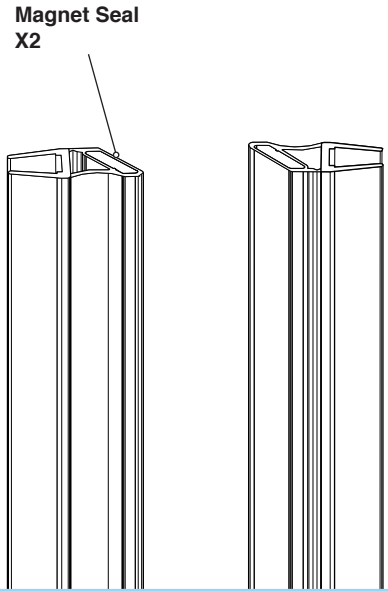

D6



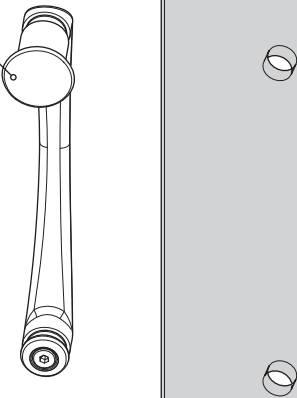

Handle Assembly X2

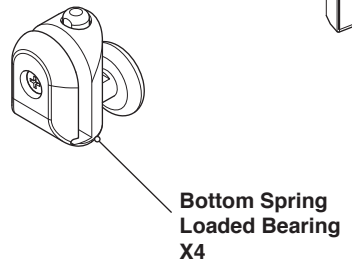

D7

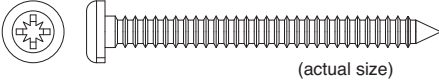

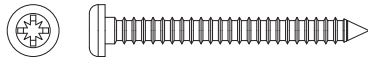
Loose Screws & Fittings Supplied

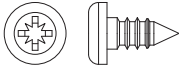
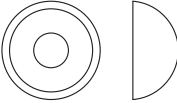
(A)	No.6 x 1/2" Pan Head Pozi Screws		Qty x4
(B)	No.8 x 1 3/4" Pan Head Pozi Screws	 (actual size)	Qty x8
(C)	Wall Plugs	 (actual size)	Qty x8
(D)	No.6 x 1 3/4" Pan Head Pozi Screws	 (actual size)	Qty x8
(G)	Screw Snap Base	 (actual size)	Qty x8
(F)	No.8 x 3/8" Pan Head Pozi Screws	 (actual size)	Qty x8
(G)	Screw Snap Cap	 (actual size)	Qty x8

Inside View

Inside View

1



Fix through pre-drilled holes

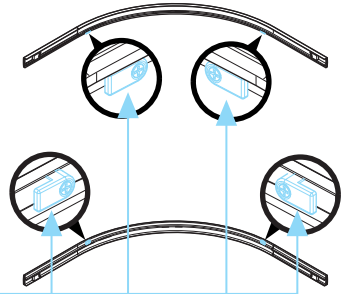

Inside View

2

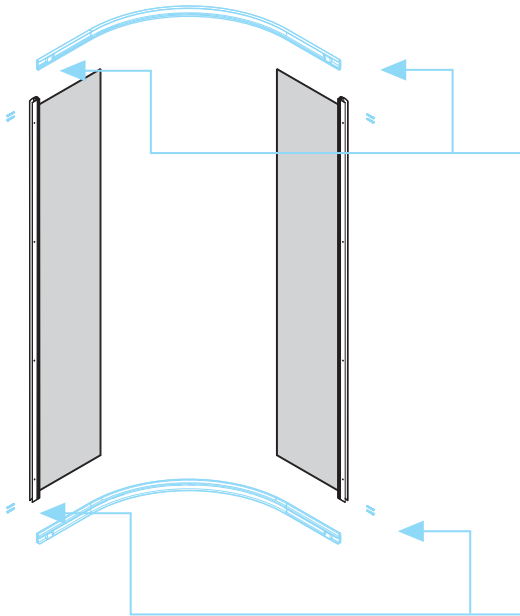

Inside View

Fix through pre-drilled holes

D

Inside View

Fix through pre-drilled holes

D



Ensure Glass Side Panels are located into glass holders as shown.

Inside View

3

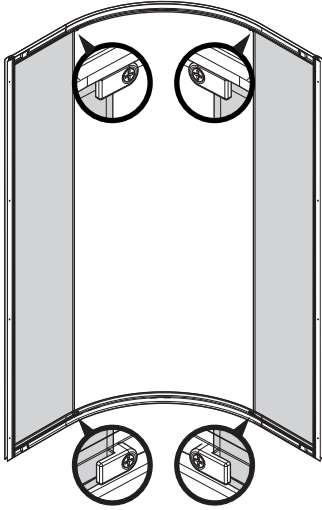

Ensure Glass Side Panels are located into glass holders as shown.

Inside View

4

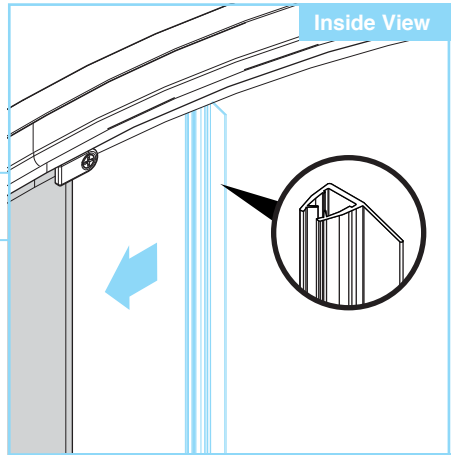
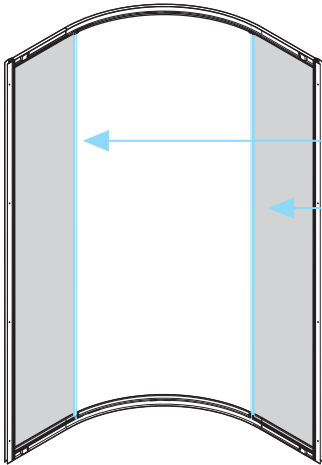

Tip: To push fit Side Panel Blade Seal, start at the bottom and work up.



Note:
Two different Seal, lengths supplied. Use Shorter of the two seal lengths at this stage.



Do NOT fix Wall Channels at this stage.
Ensure Wall Channel is level and mark position.

5

Mark Wall Channel positions.

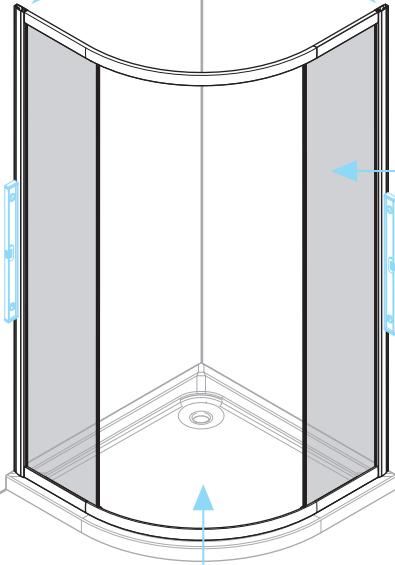

5.1

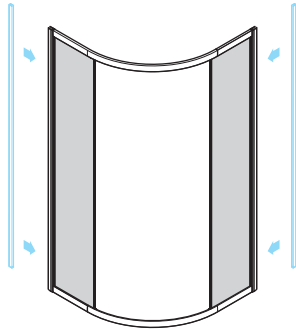

5.2

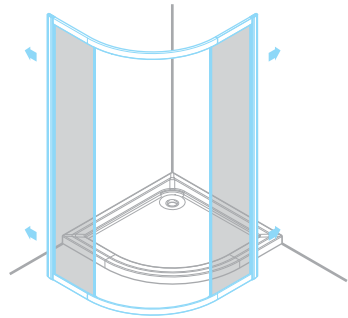

Plan View

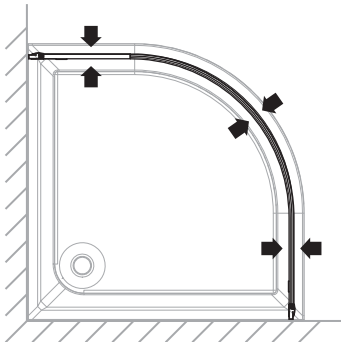

IMPORTANT NOTE

Ensure radius of enclosure matches tray.
DO NOT push Wall Channels fully into frame, allow a suitable gap to ensure adjustment and fixing.



Tip:
When drilling tiles apply masking tape to surface to stop drill bit slipping.



Wall plugs supplied are for solid walls only. Ensure correct wall plug for wall type is used. If in doubt seek professional advice.



Position wall channel on wall. Ensure channel is vertically level and does not overhang the shower tray.

6

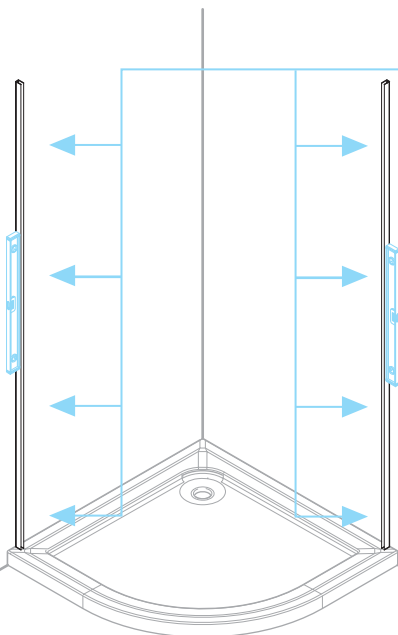

6.1

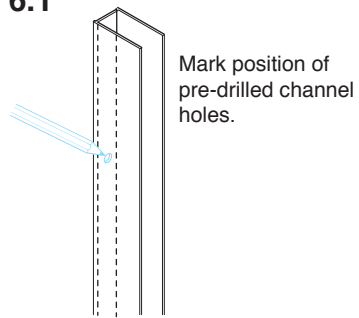

Mark position of pre-drilled channel holes.

6.2

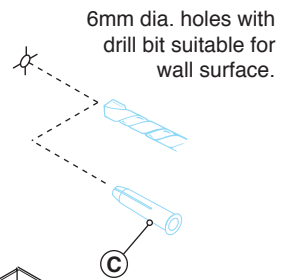

6mm dia. holes with drill bit suitable for wall surface.

6.3

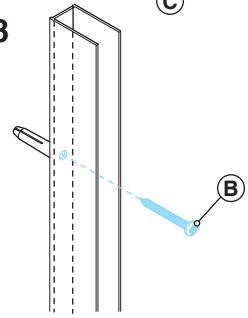

7

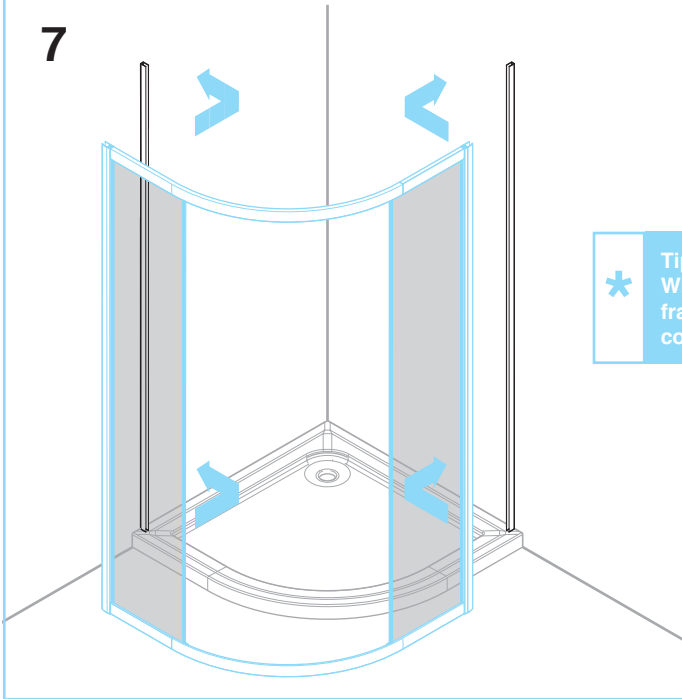

Tip:
When positioning frame, hold frame and position bottom corners first.

Inside View

8

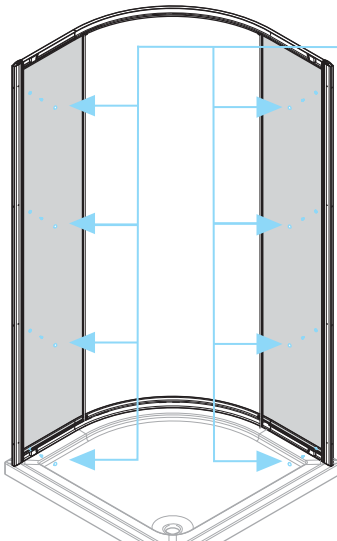

Ensure glass is positioned straight and is parallel with tray.

Inside View

*3mm dia. holes through pre-drilled holes using HSS drill bit.

8.1*

8.2

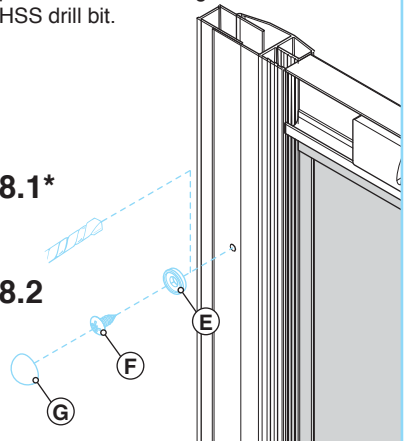

Tip:
When inserting screws apply a small amount of oil to the screw thread to allow easier fixing.

Inside View

9

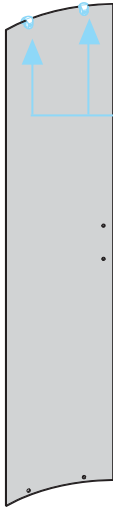

Please Note: Top adjustable Bearing and Bottom Spring Loaded Bearing variations. Use TOP ADJUSTABLE BEARING only.

Inside View

9.1

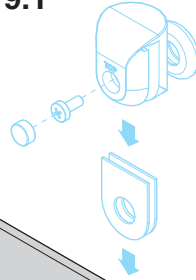

Please Note: Top Adjustable Bearings are supplied fully assembled. Disassemble part prior to fixing.

10.1

Inside View

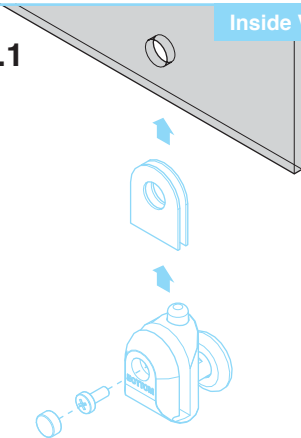

Please Note: Bottom Spring Loaded Bearings are supplied fully assembled. Disassemble part prior to fixing.

10

Inside View

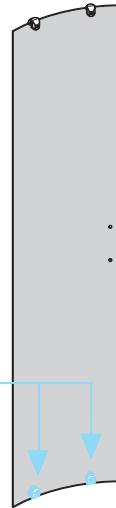

Please Note: Bottom Spring Loaded Bearing and Top adjustable Bearing variations. Use BOTTOM SPRING LOADED BEARING only.

Inside View

11



Inside View

11.1

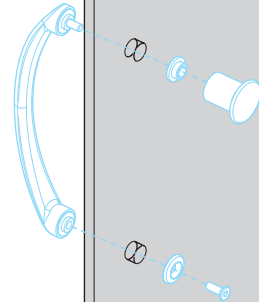

Please Note: Door Handles are supplied assembled. Using Allen key supplied, disassemble part and then re-assemble as shown. Ensure all screw heads are on the enclosure interior. DO NOT overtighten.

Inside View

12

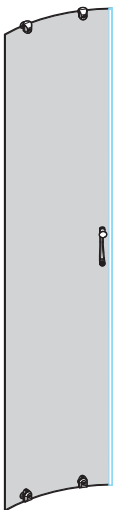

Inside View

12.1

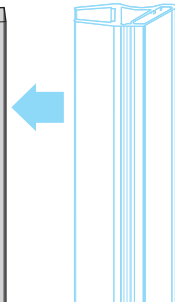

Tip: Push fit Magnet Seal, start at the bottom and work up.

Inside View

13



Ensure Door Blade Seal is fitted with blade facing away from enclosure, (as Shown).

Inside View

13.1

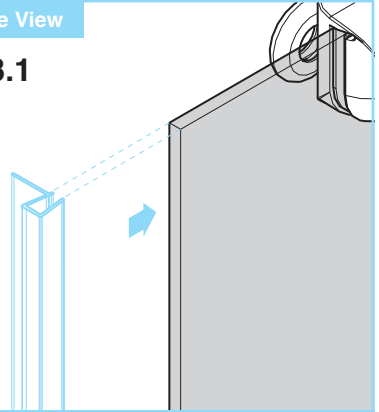

Tip:
Push fit Door Blade Seal, start at the bottom and work up.



Note: Two different Blade Seal lengths supplied. Use longer of the two versions at this stage.

Inside View

14

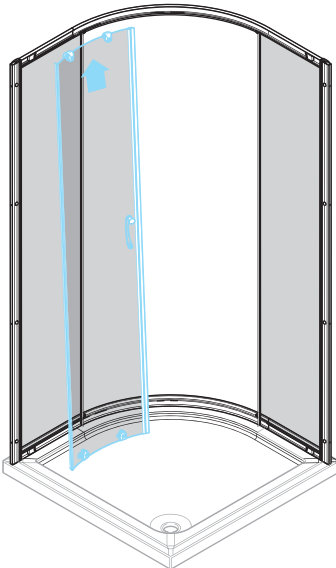

Tip:
Locate bearing wheels on the top rail first.

Inside View

15

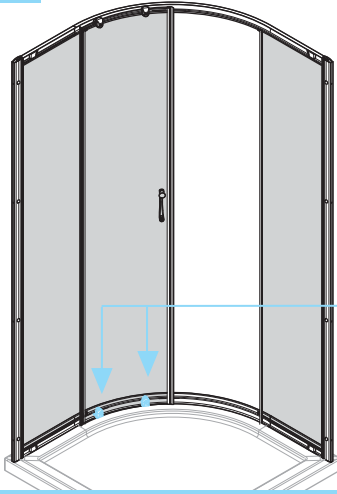

Tip: Push button down and mount bearing wheels from the outside of enclosure onto the rail, then release button to lock into place.

15.1

Inside View

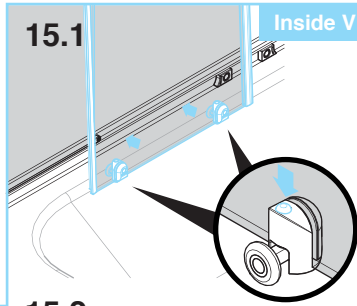

15.2

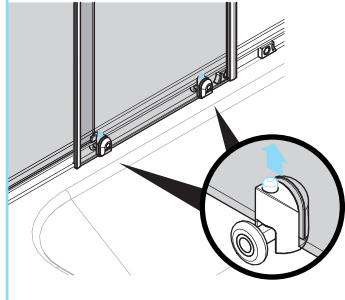

Inside View

16

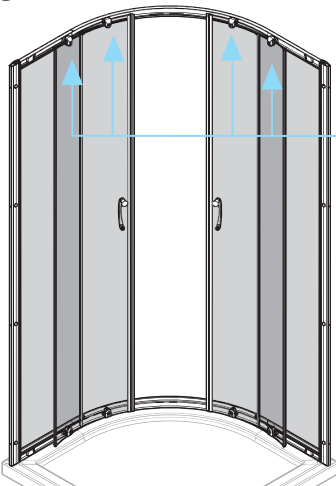

! Ensure free movement of door. Adjust to suit.

Inside, Underside View

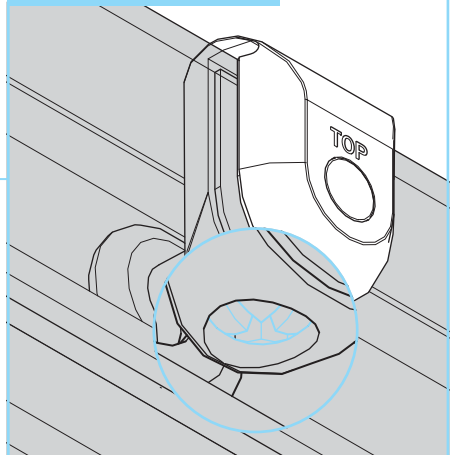

Tip: When door is correctly located, door position can be adjusted up and down using Top Bearing adjustment screws (above).

17

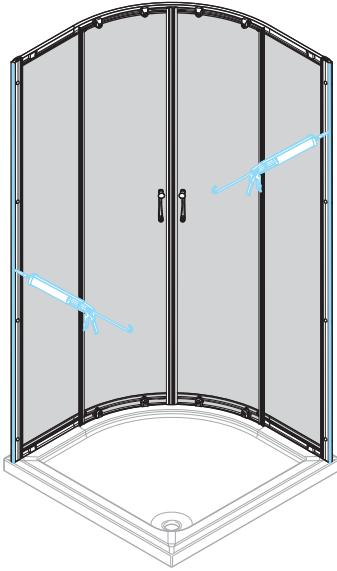

Apply Silicone sealant, (not supplied) between Wall Channel as shown.

18



Apply Silicone Sealant, (not supplied).



Product Care:
Use a non-abrasive cleaner. Water marks may be removed with a proprietary limescale remover or household vinegar.

24 hour

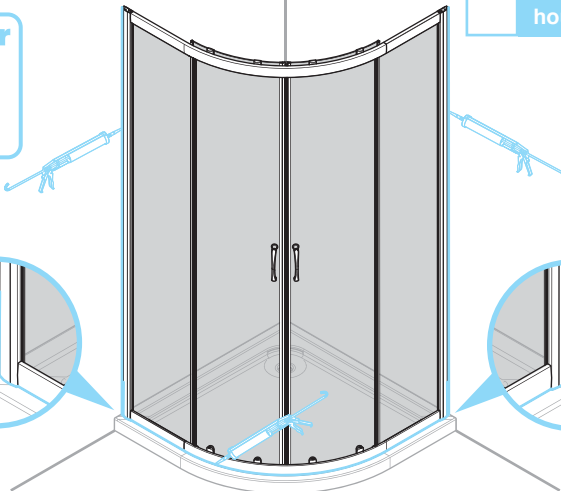

150mm

150mm