

BRISTAN

Installation Instructions and User Guide

Wall Mount 11 First Fix Kit

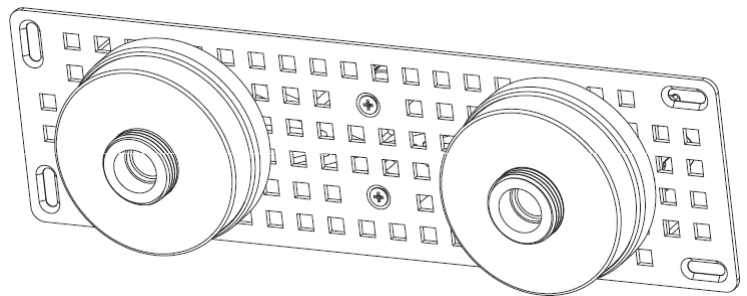

Model covered: WMNT11 C

Please keep this booklet for future Reference.

Installer, when you have read these instructions please ensure you leave them with the user.

General Information

Thank you for choosing Bristan, the UK's leading taps and showers expert. We have designed this product with your enjoyment in mind. To ensure that it works to its full potential, it needs to be fitted correctly. These fitting instructions have been created to give you all of the information you need and, if you need any further help, please do not hesitate to give us a call on 0844 701 6273.

- Please read these instructions thoroughly and retain for future use.
- All products manufactured and supplied by Bristan are safe provided they are installed correctly, used correctly and receive regular maintenance in accordance with these instructions.
- **If you are in any doubt about your ability to install this product safely you must employ the services of an experienced qualified plumber.**
- Remove all packaging and check all components before starting installation.
-  **Warning:** Before starting any installation please consider the following: Prior to drilling into walls, check that there are no hidden electrical wires, cables or water supply pipes. This can be checked with the aid of an electronic detector.
- If power tools are used do not forget to:
 - Wear eye protection
 - Unplug equipment after use
- This product **must not** be modified in any way as this will invalidate the guarantee.
- Your fitting has components with a high quality finish and should be treated with care to preserve the visible surfaces. All finishes will wear if not cleaned correctly. The only safe way to clean your product is to wipe with a soft damp cloth. Stains can be removed using washing up liquid. All bathroom cleaning products (powders and liquids) will damage the surface of your fitting, even the non-scratch cleaners.

Note: Never use abrasive detergents or disinfectants or those containing alcohol, hydrochloric acid or phosphoric acid.



Bristan recommend E-cloth for cleaning all of our bathroom & kitchen products. Using just water, E-cloth gives a smear free, deep clean by breaking up and holding dirt, which normal cloths leave behind. Order through your Bristan stockist (order code: ECLOTH).

Installation

1. Choose position

Choose the position where the wall mount fixing will be installed.

Mark a 230mm x 50mm rectangle on the plaster board wall surface where the wall mount fixing is to be fitted.

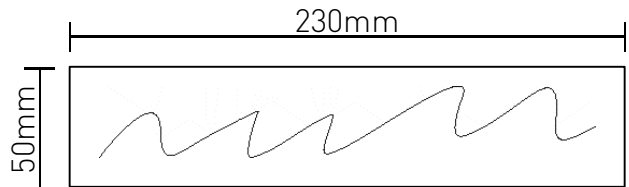

⚠ Warning: Please check for any hidden electrical wires, cables or water supply pipes before drilling / cutting into the wall.

Cut out the marked rectangle in the plaster board.

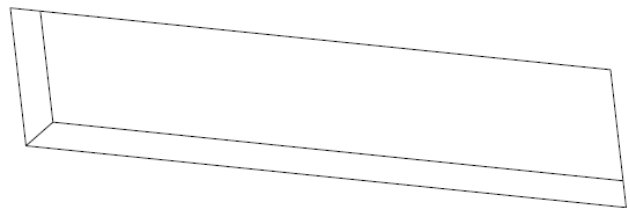

2. Terminate pipework

Terminate sufficient 15mm diameter supply pipes 150mm apart through the plasterboard wall surface ensuring a sufficient amount protrudes through the wall surface.

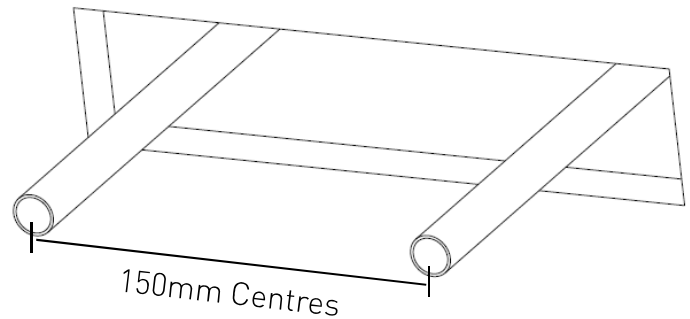

3. Fit backplate

Push the backplate over the protruding pipework.

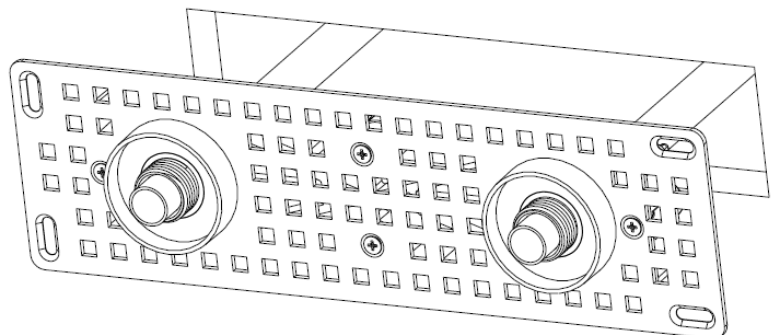

Installation

4. Secure backplate

The backplate has two methods of fixing.

a) Tighten backplate fixing lugs

Tighten the two screws in the middle of the backplate and the two screws either side of the inlet holes. By tightening these screws it will tighten the backplate fixing lugs against the plaster board.

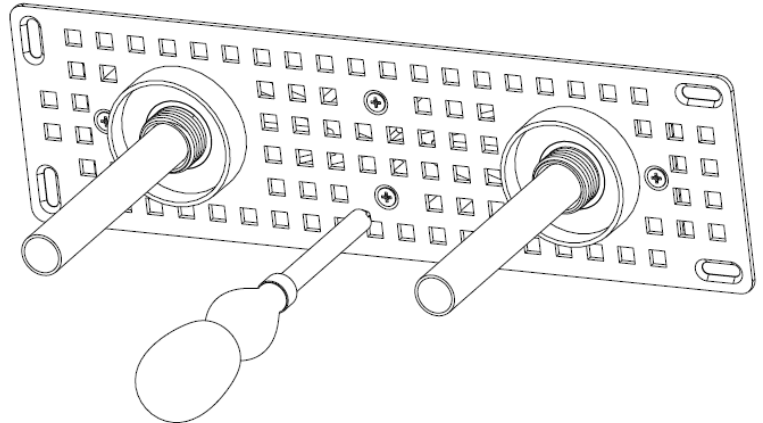

b) Screw backplate to wall

Using suitable screws secure the backplate to the plasterboard wall surface. The backplate has holes in each corner to allow for suitable fixings.

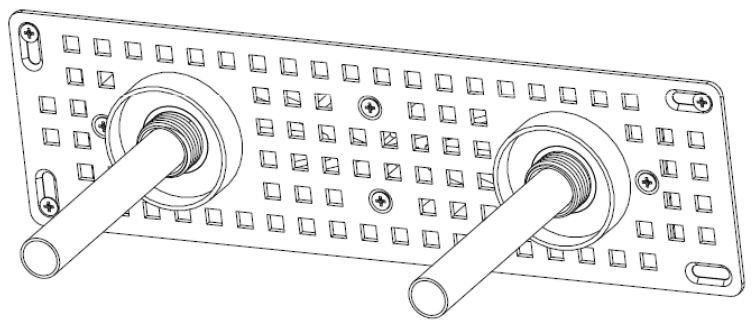

5. Cut pipework

Once the backplate has been secured to the wall surface the pipework will need to be cut back. There must be 10mm +/- 2mm of pipework protruding past the brass insert on the backplate.

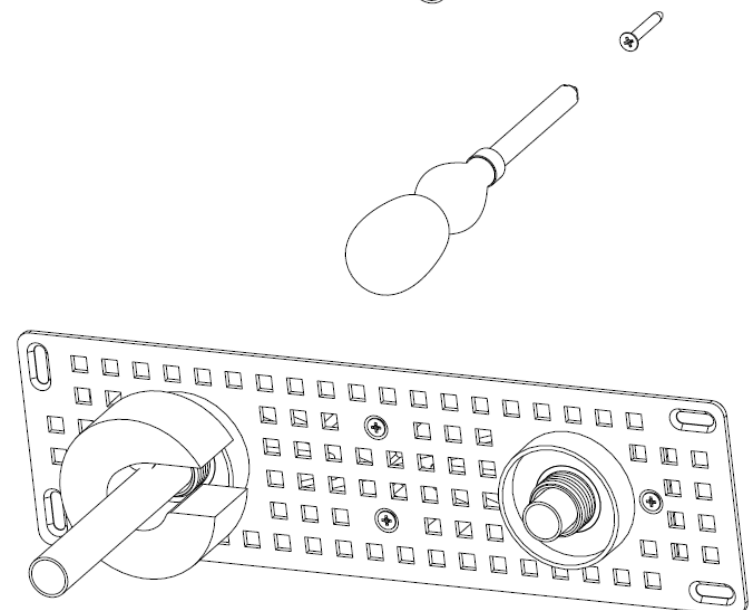

Installation

6. Fit olive and connector

Place the olives over the protruding supply pipework.

Screw the threaded fixing bridge connectors onto the backplate until just tight and then tighten a further $\frac{1}{2}$ to $\frac{3}{4}$ turn to compress the olives.

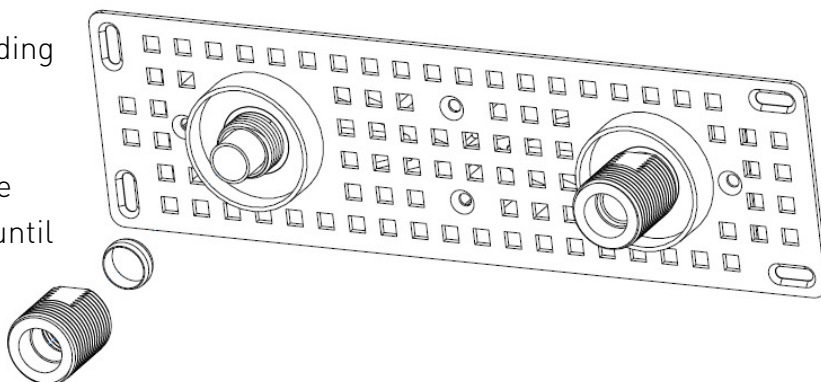

7. Finish wall surface

Complete the wall surface by tiling over the backplate as shown in the diagram opposite.

This wall fixing is suitable for tile thicknesses between 6-15mm.

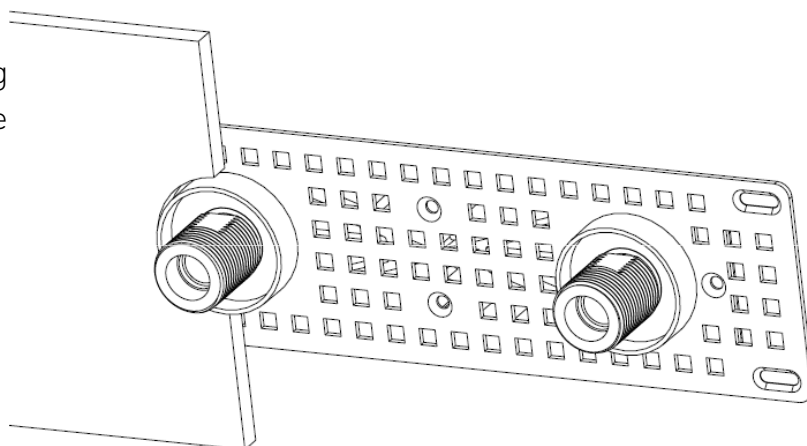

8. Fit shrouds

Screw the shrouds onto the threaded fixing bridge connectors. The front shrouds can be adjusted to suit different thicknesses.

Once installed this wall mount fixing kit will accept all bar type showers with 150mm centres.

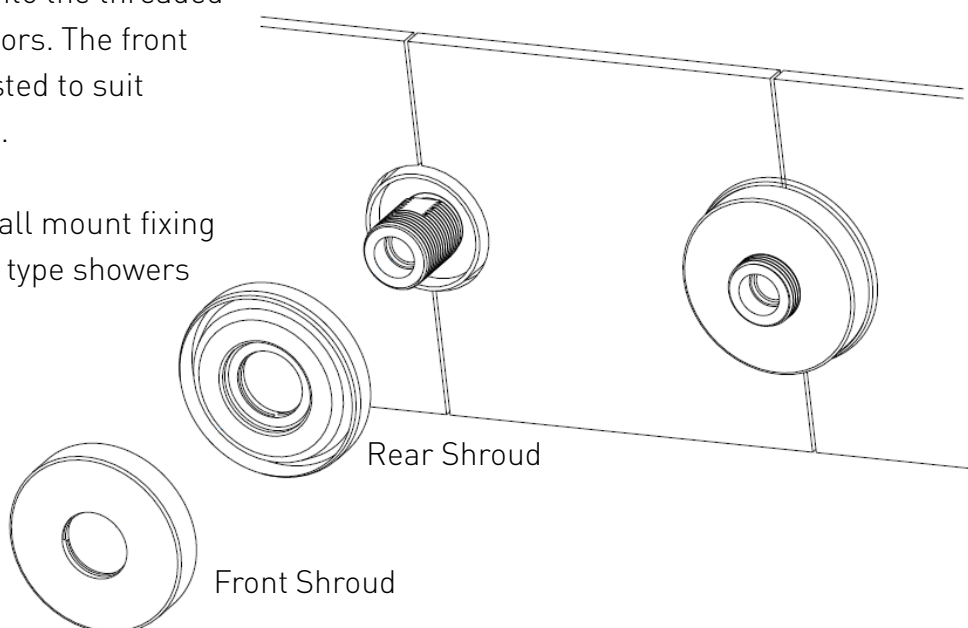

Guarantee

Bristan offers solid guarantees to provide you with complete peace of mind.

Taps and Mixers

5 year parts and 1 year labour*.
Gold, painted and special finishes
3 years parts only.

All subject to proof of purchase.

Mixer Shower Valves

1 year parts. 1 year labour* (subject to registration), or 1 year with proof of purchase.

Gold, painted and special finishes 3 years parts only.

Pumps and Power Showers

2 year parts. 1 year labour* (subject to registration).

Electric Showers/Instantaneous Water Heaters

2 year parts. 1 year labour* (subject to registration).

Accessories

5 year parts only. Includes bathrooms accessories, shower accessories (e.g. hoses, handsets and poles), wastes, WC levers and light pulls. Gold, painted and special finishes 3 years parts only.

Sanitaryware

5 year parts only. Subject to proof of purchase.

Shower Enclosures and Shower Trays

10 year parts (subject to registration), or 2 years with proof of purchase. 1 year labour* (subject to registration), or 1 year with proof of purchase.

Heated Towel Rails

5 year parts only. Gold, painted and special finishes 3 years parts only. All subject to proof of purchase.

*Labour provided by an approved Bristan engineer. Guarantee only applies to products with a manufacturing fault. A deferred payment will be necessary in order to secure any visits by our engineers which will be charged if the problem is found **not** to be a manufacturing fault. If the fault is found to be down to a manufacturing error, the payment will be released and not charged.

This guarantee applies to products purchased within the United Kingdom or Republic of Ireland, but does not apply to products used commercially.

The guarantee is only available to original purchasers who have proof of purchase.

The installation must allow ready access to all products for the purpose of inspection, maintenance or replacement.

Any part found to be defective during the above guarantee period will be replaced without charge, providing that the product has been installed in accordance with the instructions, used as intended, and regularly serviced.

Servicing should be carried out at regular intervals of no more than 12 months and more frequently in hard water areas (heavy lime scale) areas.

In the unlikely event that any problems are encountered with the product's performance on installation, you must obtain guidance/authorisation from our Customer Service Department, and be able to supply proof and date of purchase, before any remedial action is taken.

The guarantee excludes general wear and tear and damage caused by accident, misuse or neglect, and does not cover the following:

Guarantee & Service Policy

- Components that are subject to general wear and tear such as filters, seals, 'O' rings and washers etc.
- Damage caused by faulty installation
- Damage caused by lime scale or any waterborne debris
- Damage caused by inappropriate cleaning products (see cleaning section)
- Damage caused by the use of non-Bristan parts
- The product being used for a purpose other than intended by the manufacturer.

In the interests of continuous product improvement Bristan reserves the right to alter specification as necessary.

Replacement Parts Policy

Important:

In the event of product or component malfunction, DO NOT tamper with or remove the product from site. Telephone the Customer Services Department and be prepared with the date of purchase, model number and a clear description of the complaint.

Our service staff are fully qualified to advise on correct installation procedures and will be able to diagnose whether the fault will require a replacement part or a visit from a Bristan engineer.

If required, a service call will be booked and either yourself or an appointed representative (who should be a person of 18 years or over) must be present during the visit.

All site visits to products out of guarantee will be carried out free of any parts or labour charges provided the conditions of the guarantee have been adhered to (the 2nd to 5th year of the guarantee is parts only, unless registered).

All site visits to products out of guarantee will be subject to charges for parts and labour. Charges will also be levied on cancelled appointments, unless advised to Bristan at least 24 hours in advance of the agreed date and time.

Should a product be discontinued, Spare parts stocks will be maintained, but in the event of a part becoming unavailable Bristan reserve the right to supply a substitute of equal quality.

In order to log an enquiry with us please visit <http://www.bristan.com/customerservice>

Please visit: www.bristan.com/sparesfinder in order to find spare parts for this product.

Opening times: Please refer to the Bristan website.

Customer Service: **Tel: 0844 701 6273 • Fax: 0844 701 6275**

Part Number: WMNT11 C

Issue: D2

BRISTAN

Bristan Group Ltd.
Birch Coppice Business Park
Dordon
Tamworth
Staffordshire
B78 1SG
Web: www.bristan.com
Email: enquire@bristan.com

A Masco Company