



TT VALVE

THERMOSTATIC SHOWER VALVE
FIRST FIX KIT



Installation Instructions

A3969NU TT Thermostatic Valve First Fix Kit

INSTALLER:

*It is essential to flush the system as described in section 7
After installation please pass this instruction booklet to the user*

The fittings covered by these instructions should be installed in accordance with the Water Regulations published in 1999*. Ideal Standard strongly recommends that these fittings are installed by a professional fitter.

*A guide to the Water Supply (Water Fittings) Regulations 1999 and the Water Byelaws 2000, Scotland is published by WRAS (Water Regulations Advisory Scheme) Fern Close, Pen-y-Fan Industrial Estate, Oakdale, Newport, NP11 3EH. ISBN 0-9539708-0-9

1 SCOPE

This thermostatic shower mixer is designed to be installed on normal UK low pressure storage tank fed systems, unvented high pressure systems, modulating instantaneous water heaters or modulating combination (combi) boilers. It is suitable for all pumped applications.

2 WATER REGULATIONS

Hot and cold water supply pressures must be reasonably balanced and from a common source. The mixer will function within specification on unequal pressures up to a ratio of 5:1, but it is not recommended that the cold supply be connected to the rising main and hot to the tank fed supply.

The minimum pressure for correct operation is 0.1 bar (1m head measured from the base of the cold storage tank to the shower spray plate - see figs 5 & 6). For TMV3 applications see table 1

When installing with a shower pump a dedicated secondary tapping from the cylinder is highly recommended. Fig1 shows the various methods of connecting the hot water pipe from the cylinder.

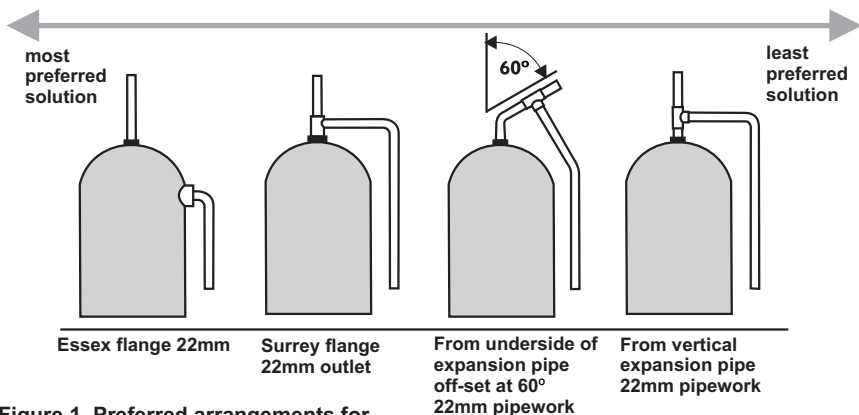

Figure 1 Preferred arrangements for cylinder tapping

The fitting and the isolation valves should be so installed as to be readily accessible for examination, repair, replacement or operation. (IRN 111).

The temperature of the hot water must not exceed 85°C it is recommended not to exceed 65°C (BS6700). For correct operation of the valve, 52°C min is required. See table 1.

For Healthcare Establishments

In accordance to NHS model engineering specifications DO8 the valve has approval for the following applications:-

High pressure	- HP	-S
Low pressure	- LP	-S

For this type of application the supply conditions in table 1 must apply:

3 CONDITIONS FOR NORMAL USE

Table 1 Supply conditions for normal use

Operating pressure range	High Pressure	Low Pressure
Maximum static pressure (Bar)	10	10
Flow pressure hot and cold (Bar)	1 to 5	0.2 to 1
Hot supply temperature (°C)	52 to 65	52 to 65
Cold supply temperature (°C)	5 to 20	5 to 20
Temperature differential characteristic (TDC) (C°)	10	10

Valves operating outside these conditions cannot be guaranteed to comply with the TMV3 scheme

MODULATING COMBINATION BOILERS

This thermostatic shower valve is designed for use with modulating combination boilers.

When installing on high pressure systems, pipework to the thermostat should be in 15mm copper. When installing on a modulating combination boiler it is sometimes possible for the interaction of a thermostatic valve with the boiler to cause the boiler to cut out and cut in again with the result that the water will become alternately cold and hot. In most cases this can be overcome by fitting the flow regulator supplied. It should be fitted in any 15mm compression fitting in the **dedicated cold supply pipe** upstream of the thermostatic valve but downstream of the isolating valve/strainer.

It is important to choose a compression fitting located in a position which is accessible after installation so that the regulator may be serviced if required.

It is recommended that the flow regulator is fitted in the downstream end of the isolating valve/strainers - supplied with the mixer.

It is important to fit the regulator the correct way round as shown in Figs 2/2a.

When fitting on the downstream end of a compression fitting (Fig 2) ensure the o-ring is seated fully in the visible rebate around the edge of the regulator. Use the tip of a small screwdriver or similar to achieve this. Ensure the tail of the pipe is not fouling the regulator (shorten if required) and tighten the compression fitting as normal.

In a minority of cases, where the boiler is of a type which stores a small quantity of very hot water, it may also be necessary to fit a 5 l/min flow regulator in the hot supply. These can be obtained from Customer Care.

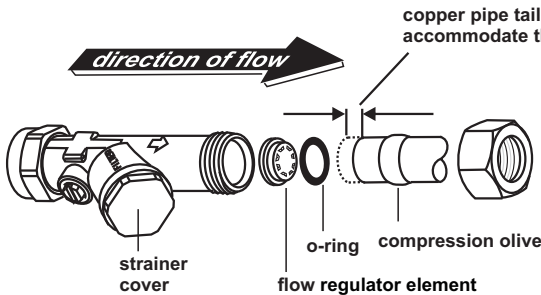

Figure 2 Fitting the regulator in the downstream end of the iso' valve/strainer

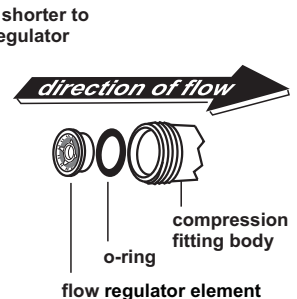

Figure 2a Fitting in the upstream end of a compression fitting

4 BACK SYPHONAGE PROTECTION

It is a requirement of the Water Regulations for the installer to assess the back syphonage risk should the flexible shower be capable of coming within 25mm of the spill-over level of any adjacent bathroom fixture.

SHOWER TRAYS, BASINS AND BATHS

Water in a shower tray, basin or bathtub is considered to be a fluid risk category 3. This is a fluid which represents a slight health hazard if it were to find it's way back into the supply pipe. For this reason it must not be possible for a flexible shower head to be able to enter any adjacent washbasin, bath or shower tray unless the inlets to the shower valve are protected by double check valves. If such protection is not present the shower hose must be restrained or shortened. Figure 3

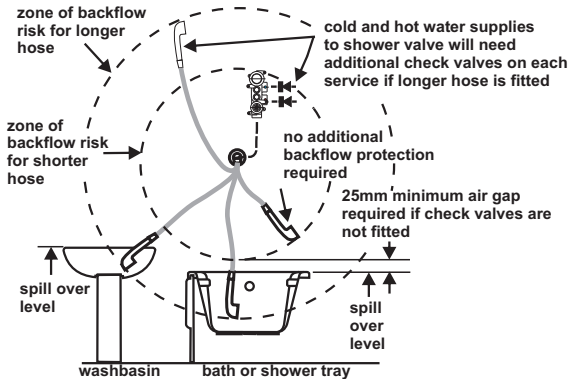

Figure 3 Backflow risk from a fluid category 3

WC'S, SINKS AND BIDETS

Water in a sink, WC or bidet is considered to be a fluid risk category 5.

This is a fluid which represents a serious health hazard if it were to find it's way back into the supply pipe. For this reason it must not be possible for any flexible shower head to be able to enter any adjacent sink, WC or bidet.

If the flexible shower can reach within 25mm of the spill-over level of any sink, WC or bidet, a design change must be made such as restraining the hose or using a shorter one.

Installers and users must comply with this requirement when a replacement shower hose is being fitted.

Check valve protection is not permitted for category 5 fluids. See Figure 4.

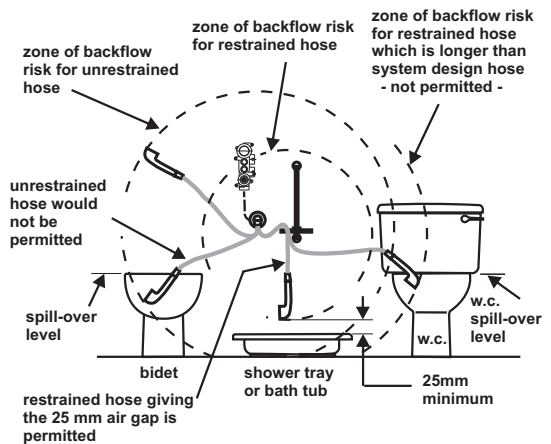

Figure 4 Backflow risk from a fluid category 5

5 GRAVITY & PUMPED SYSTEMS

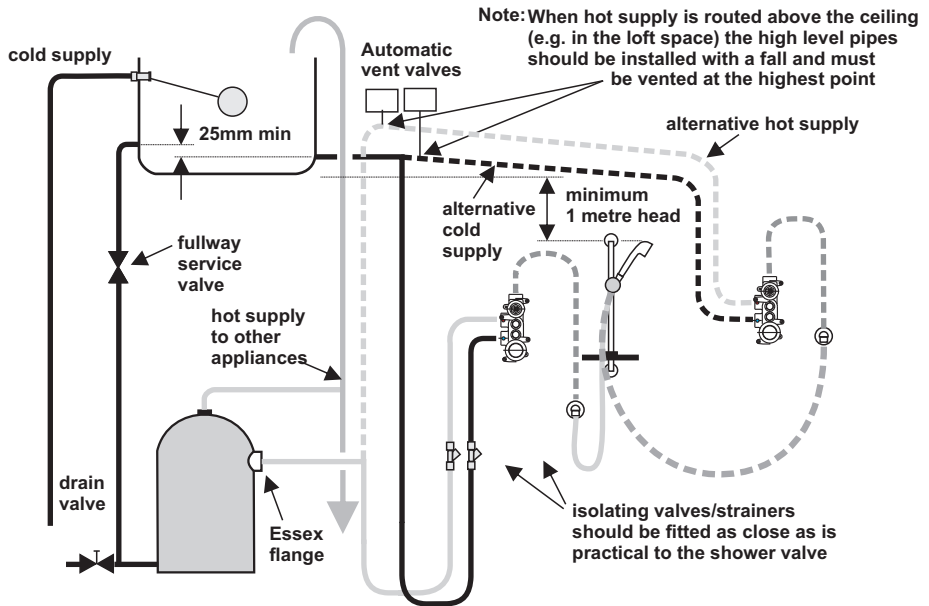

Figure 5 Recommended system layout for gravity applications

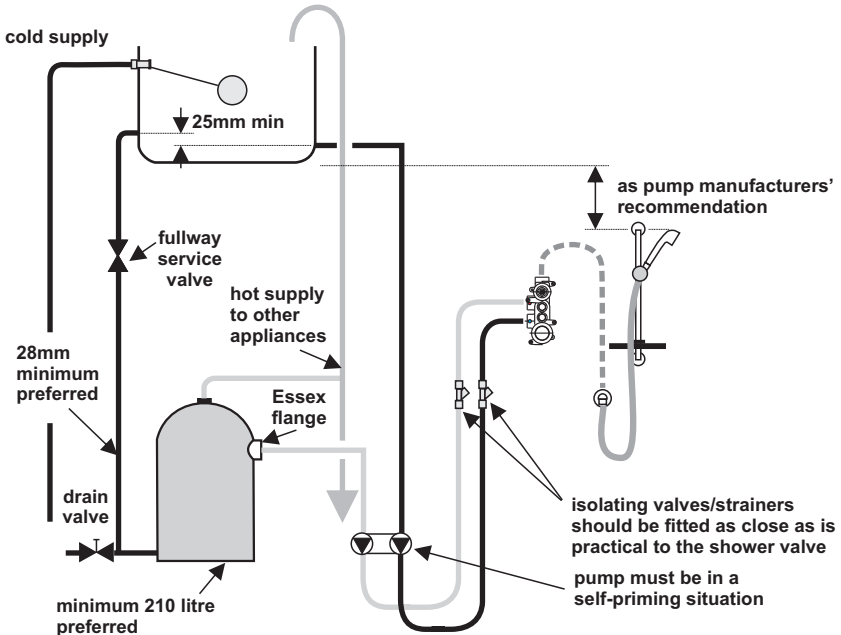

Figure 6 Recommended pumped system layout

6

TECHNICAL DIMENSIONS

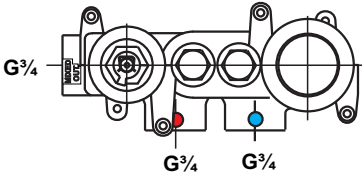
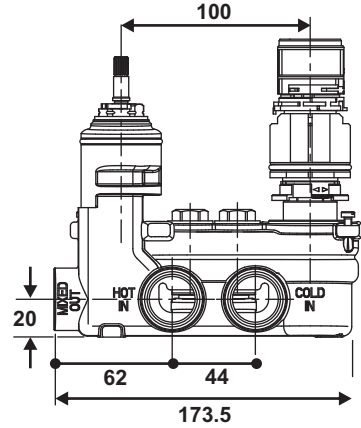

Figure 7 Roughing in dimensions



INSTALLATION GUIDE

Connections on the built-in mixer body are G $\frac{3}{4}$ (female) and are marked “hot in”, “cold in” and “mixed out” on the body casting. For maximum flow performance on gravity and pumped systems pipework should be run to the valve in 22mm copper. The G $\frac{3}{4}$ to 22mm connectors should be joined to the valve body using traditional fibre plus jointing compound. (If PTFE tape is used special care must be taken to ensure the joint is water tight before plastering the wall.) Under no circumstances should soldered joints be used near the valve body as this will damage the fitting.

The isolation valves should be fitted close to the valve body and still be accessible after installation.

The valve is supplied ready for installation as per position 1 in figure 8. If a configuration as shown in position 2 is required then the temperature adjustment carrier will need to be repositioned. To do this, remove the temperature adjustment carrier by rotating the black serrated lever ('f' in fig 12) clockwise. The carrier can then be pulled off. Refit the carrier by pushing it on - it will snap into position - with the triangular raised mark ('a' in fig 12) at the top.

If a horizontal arrangement such as it shown in fig 8a the installer should be aware that some 2nd fix kits are not suitable for these positions (3 and 4).

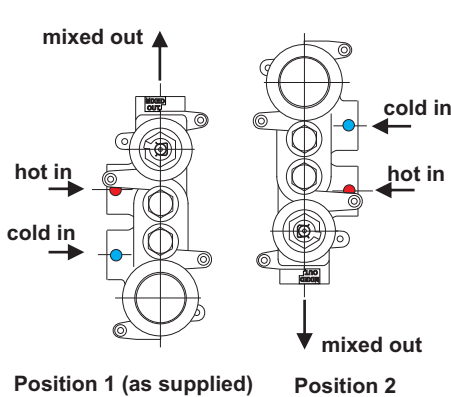

Figure 8 Preferred installation orientation

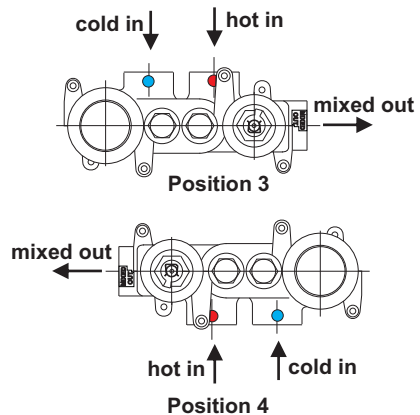

Figure 8a Horizontal installation orientation (not suitable for some trim kits)

7 BUILDING-IN

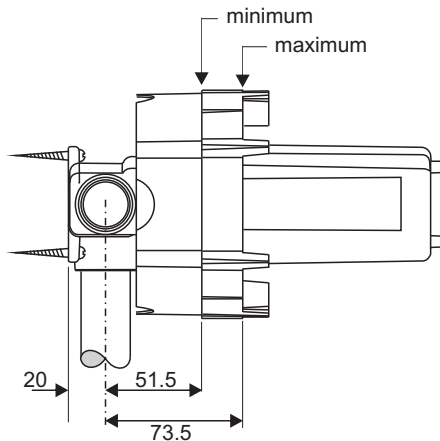

Figure 9 Build in depth

1. This thermostatic valve is designed to be recessed into the wall. The depth of the recess should be measured from the finished wall surface to the rear of the valve body. The recess depth is in the range 71.5mm min to 93.5mm max. Minimum and maximum depths are marked on the plaster guard (11).

2. Chase wall for mixer body and pipe work.

3. Remove plaster guard (11).

4. Connect the pipe work and remember not to solder near the valve body. **Test the in-wall pipework for leaks before plastering.**

5. Replace the plaster guard and check that the valve is level. The four bosses on the front of the plaster guard allow a spirit level to be placed on or against it. Check also that the valve is parallel to the wall surface.

6. Make good the wall by plastering around the valve up to the plaster guard.

7. Once the plaster has set the wall can be tiled using the tiling template which is delivered with the face plate in the second fix kit. This should be located by placing it over the plaster guard and attached to the wall using tile adhesive. When the face plate is fitted this permits a good seal to be made with the wall.

(See section 8 for illustrations)

8. If the valve is not being fitted in the orientation as supplied then the temperature adjustment carrier will have to be repositioned as described in section 6

9. The pipe work and valve body must now be flushed out otherwise the thermostatic cartridge filters could become blocked resulting in reduced or erratic performance.

To do this, remove the check valve housing (7) from the hot side as described in section 9. Turn on the hot supply until all debris has been purged from the system then replace the check valve.

Repeat the procedure for the cold side check valve (6). After flushing check and clean the strainer elements in the isolating valves.

SECOND FIX KIT

This comprises the shrouds, face plates and handles and is available separately. Fit the shrouds and then push the black plastic back cover plate over them until its seal engages with the tiling template. Secure using the fixing screws provided. (One of these may have to be cut if the valve is installed close to the minimum depth.) Push the front cover plate into position and fit the operating handles. (See instruction leaflet E96549200, packed with the second fix kit, for details.)

IN-LINE STRAINERS

This valve is supplied with isolating valves / strainers which should be fitted as detailed in section 3. This will help protect the delicate mechanisms from the possibility of becoming blocked by installation or other debris.

As the thermostatic cartridge seldom fails the possibility of blocked filters must always be investigated before contemplating fitting a new cartridge.

8

PLASTERING AND TILING

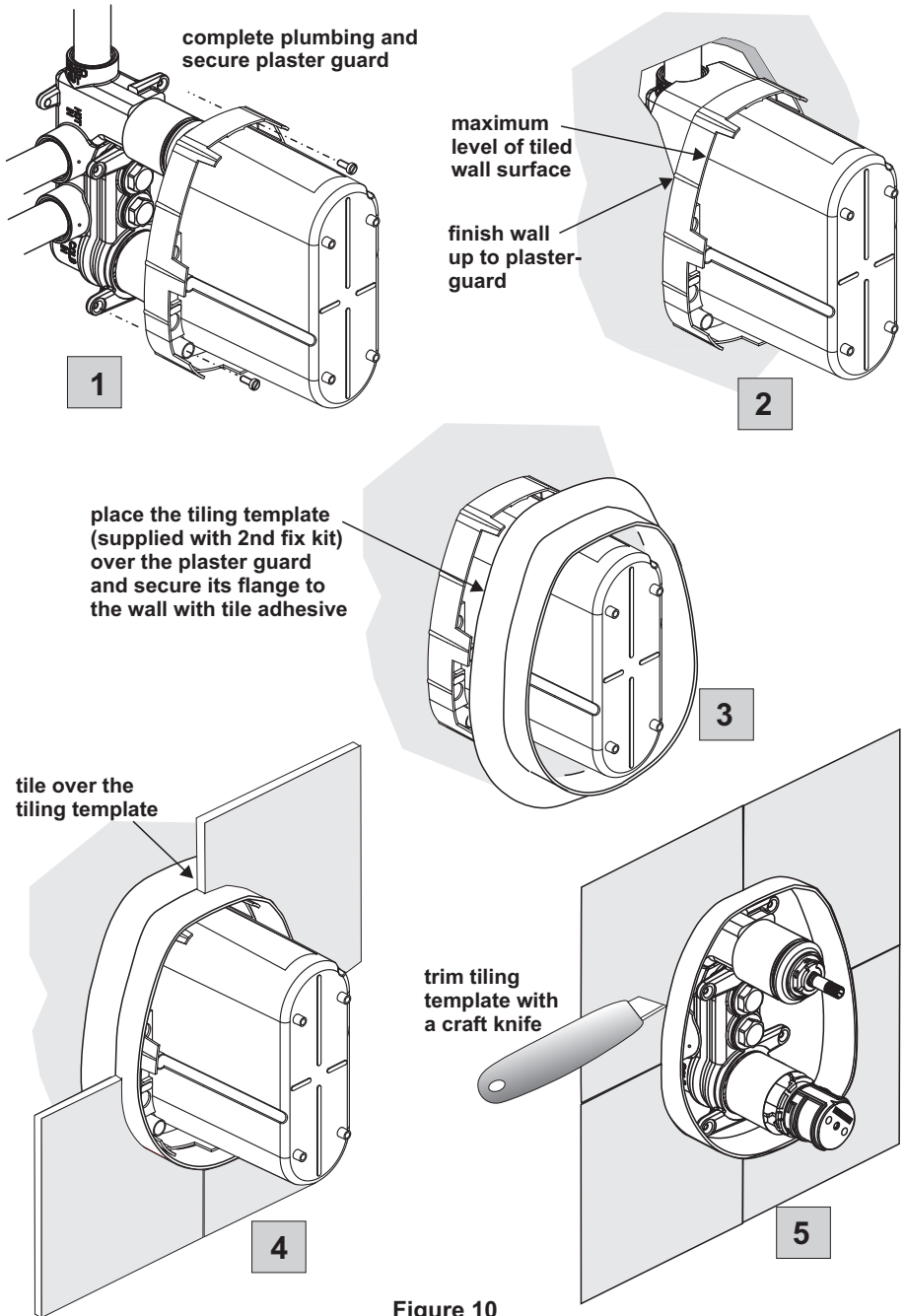

Figure 10

9

CARTRIDGE REPLACEMENT

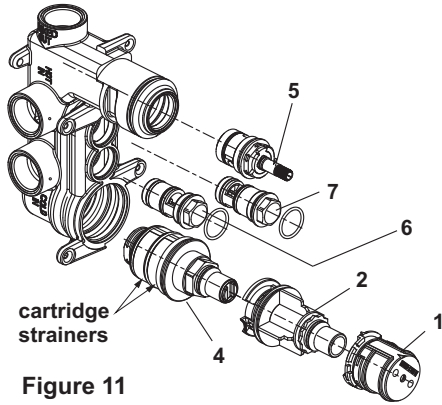

Figure 11

Servicing the thermostatic valve is simple as all working parts are in the replaceable cartridges.

In all cases the hot and cold supplies must be isolated before commencing work.

To access all the cartridges first remove the face-plate which can be prised off. The black plastic back-plates can then be unscrewed.

FLOW CONTROL CARTRIDGE

The flow control cartridge (5) can be accessed by removing the flow control handle. It is then a simple matter of unscrewing it using a 22mm spanner. Care should be taken when fitting the replacement cartridge not to allow its greased seals to become contaminated with grit as this can prevent proper seating.

THERMOSTATIC CARTRIDGE

Remove the temperature control handle and the shroud. The temperature adjustment carrier (1) can then be removed by sliding the serrated lever ("f" in fig 12) clockwise and pulling the carrier off. Remove the temperature handle extension (2) in exactly the same manner.

The thermostatic cartridge (4) can then be unscrewed using a 24mm deep socket.

It is usually unnecessary to fit a new thermostatic cartridge. Most problems occur because debris from the pipe work has blocked the cartridge filter screens, often as a result of the pipework not being flushed at the time of installation.

The cylindrical strainers can be removed for cleaning by removing the o-rings from the cartridge and sliding the strainer screens off. Do not attempt to refit the cartridge with the strainers missing. Any small particles of grit in the water supply will cause the mechanism to jam. (Place all components which have grease on them on a clean piece of paper to avoid picking up grit). Grease the cartridge o-rings with silicone grease when they have been refitted.

If the cartridge is to be replaced, fit the new one at this stage.

The valve is assembled in reverse order.

CHECK VALVES

This shower valve is fitted with check valves on both hot and cold inlets. These are necessary to prevent cross flow through the fitting between hot and cold supplies.

The check valves should normally operate without any problems but if they become blocked with, say, installation debris this could cause reduced or erratic flow.

It is a simple procedure to inspect the check valves. Remove the face plate and unscrew each of the check valve housings in turn using a 17mm socket (6 cold, 7 hot). If debris is blocking the check valve it will have to be carefully cleared out and the valve washed clean. The check valve mechanism is delicate and must be treated gently. In the event of them becoming damaged by this process replacements may be purchased by calling Customer Care - see back cover.

It is essential that the hot and cold check valves are not mixed up otherwise the thermostat will not function correctly, however, if inlet connections to the valve have been transposed the problem can be resolved by transposing the check valves.

10

COMMISSIONING AND PERIODIC CHECKS

Commissioning Procedure

The following procedure should be carried out after installation and every 6 months thereafter to ensure that the valve is functioning correctly.

Check that:

- a) The designation of the thermostatic mixing valve matches the intended application.
- b) The supply pressures are within the range of operating pressures for the designation of the valve. (see Table 1)
- c) The supply temperatures are within the range permitted for the valve and by guidance information on the prevention of legionella etc. (see Table 1)

Adjust the temperature of the mixed water (see section 14) for the requirement of the application and then carry out the following sequence:

- a) Record the temperature of the hot and cold water supplies.
- b) Record the temperature of the mixed water at the largest draw-off flow rate.
- c) Record the temperature of the mixed water at a smallest draw-off flow rate, which shall be measured.
- d) Isolate the cold water supply to the mixing valve and monitor the mixed water temperature.
- e) Record the maximum temperature achieved as a result of (d) and the final stabilised temperature.

NOTE: The final stabilised mixed water temperature should not exceed the values in Table 2

- f) Record the equipment, thermometer etc. used for the measurements.

Table 2 A guide to maximum temperature sets

Application	Mixed water temperature	Permitted maximum temperature recorded during site testing
Shower	41°C	43°C

In-service Testing

Purpose

The purpose of in-service tests is to regularly monitor and record the performance of the thermostatic mixing valve. Deterioration in performance can indicate the need for service work on the valve and/or the water supplies. **This may require the adjustment of either the supply system or the valve. The A3969NU should be checked and tested 6 to 8 weeks and again 12 to 15 weeks after commissioning. The results are to be compared against original commissioning settings. If there is no significant change (i.e. less than 1C°) then a 6 monthly servicing cycle may be adopted. If the temperature increases up to and greater than 2C° at the mixed water outlet, then servicing checks should be carried out more frequently, (every 4 months)**

Procedure

Using the same measuring equipment or equipment to the same specification as used in the commissioning of the valve, adjust the temperature of the mixed water (see section 14) for the requirement of the application and carry out the following sequence:

- a) Record the temperature of the hot and cold water supplies.
- b) Record the temperature of the mixed water at the largest draw-off flow rate.
- c) Record the temperature of the mixed water at a smaller draw-off flow rate, which shall be measured.

If the mixed water temperature has changed significantly from the previous test results (e.g. > 1C°) record the change and before re-adjusting the mixed water temperature check:

- a) That any in-line or integral strainers are clean.
- b) Any in-line or integral check valves or other anti-back siphonage devices are in good working order.
- c) The isolating valves are fully open.

With an acceptable mixed water temperature, complete the following procedure:

- a) Record the temperature of the hot and cold water supplies.
- b) Record the temperature of the mixed water at the largest draw-off flow rate.
- c) Record the temperature of the mixed water at a smaller draw-off flow rate, which shall be measured.
- d) Isolate the cold water supply to the mixing valve and monitor the mixed water temperature.
- e) Record the maximum temperature achieved as a result of (d) and the final stabilised temperature.
- f) Record the equipment, thermometer etc. used for the measurements.

If at step (e) the final mixed water temperature is greater than the values in Table 2 and / or the maximum temperature exceeds the corresponding value from the previous results by more than about 2C°, the need for service work is indicated.

11 MAINTENANCE

This thermostatic shower valve should be cleaned regularly - see below under cleaning.

The isolating valves / strainers (14) should be serviced annually.

To do this close the isolating valve (16) by turning through 90deg (figure 15 shows the valve in the closed position). Unscrew the strainer cover (15), remove the strainer gauze and clean under running water before replacing.

The greatest build up of debris on the strainer gauze is likely to occur just after installation. The installer is asked, therefore, to check the strainer after testing the system.

The unique ceramic disc cartridge is built using ultra-smooth ceramic discs. These are so hard that they always remain sealed together, polishing each other in use. Sand, sediment and other water borne matter cannot get between them or damage them. Even the hardest water has no effect and this means that this shower valve should give many years of efficient trouble free service without the drip and liming up problems associated with traditional valves.

However, in the unlikely event of a failure or any other problem it is a simple matter to exchange the cartridge. (see figure 11).

CLEANING

When cleaning the shower valve always use soap based cleaners. Never use abrasive or scouring powders and never use cleaners containing alcohol, ammonia, nitric acid, phosphoric acid or disinfectants.

12 CALIBRATION

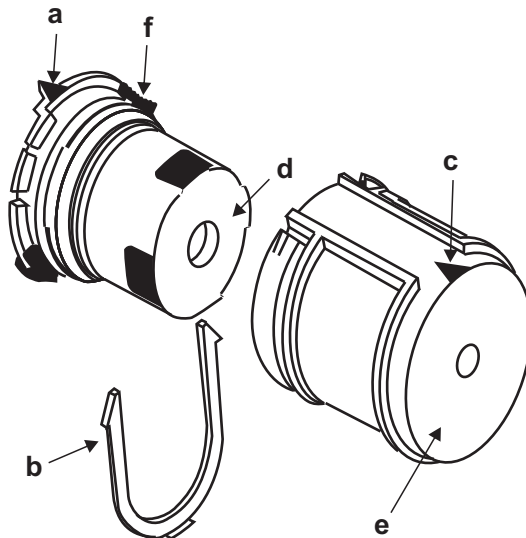

Figure 12 Temperature adjustment carrier exploded

CALIBRATION

Remove handles and wall plate or covers. Slide out the red "U" clip (b Figure 12) and disconnect the handle carrier to expose the temperature control mechanism. Turn on the shower, position a thermometer in the running water and when the temperature settles, rotate the temperature control mechanism (d) until 40 °C is achieved. Replace the handle carrier (e) ensuring the arrow (c) is at 12 o'clock. Without rotating it, refit the red "U" clip (b). Replace the covers and handles.

NOTE

Details of the recommended code of practice for safe water temperatures can be found on the Thermostatic Mixing Valve Manufacturers Association web site: www.tmva.org.uk

13

MAXIMUM TEMPERATURE STOP

The maximum mixed water temperature is factory set at 40°C. To change this temperature remove the temperature control handle. Remove the temperature limit stop (black H-shaped plastic part located in the temperature handle carrier) and reinsert it in the appropriate recess on the handle carrier. Four different settings are possible, 40°C, 43°C, 45°C & 50 °C (See Figure 13) Refit the temperature handle.

When installing in care homes it must not be possible to deliver water hotter than 41°C so the limit stop must remain at the 40°C setting.

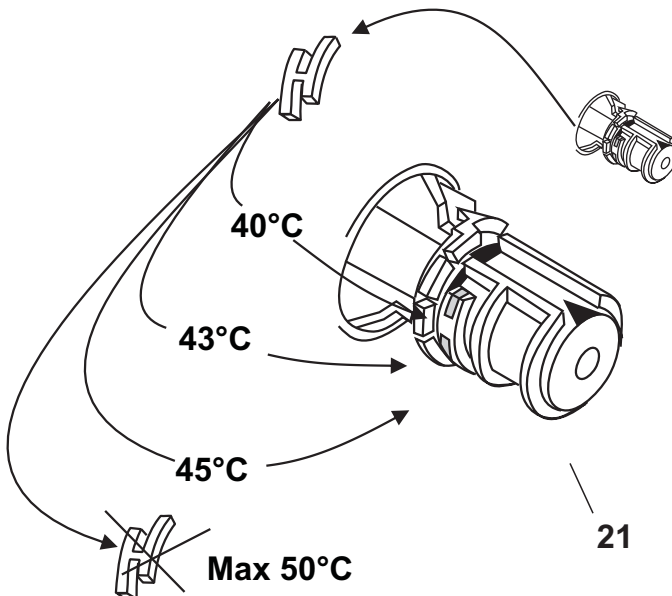

Figure 13 Adjusting the temperature limit stop

14 OPERATION

To select the desired mixed water temperature turn the temperature handle clockwise for colder and anti-clockwise for hotter. (see figure 14)

Temperatures greater than 40°C can only be accessed by sliding the button forward and continuing to turn anti-clockwise. The maximum temperature available is determined by the position of the maximum temperature stop. (see section 13 above)

The flow is controlled by the flow control handle. The button is a water saving feature which limits the flow to around 50% of maximum. For greater flow rate push the button inwards and continue to turn

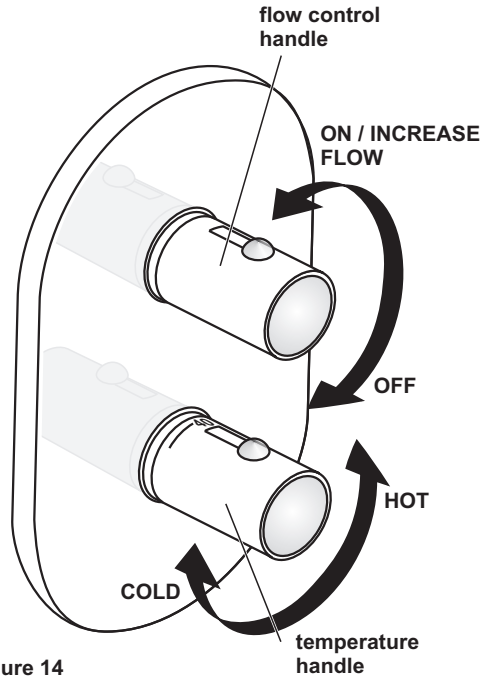

Figure 14

15 SPARE PARTS

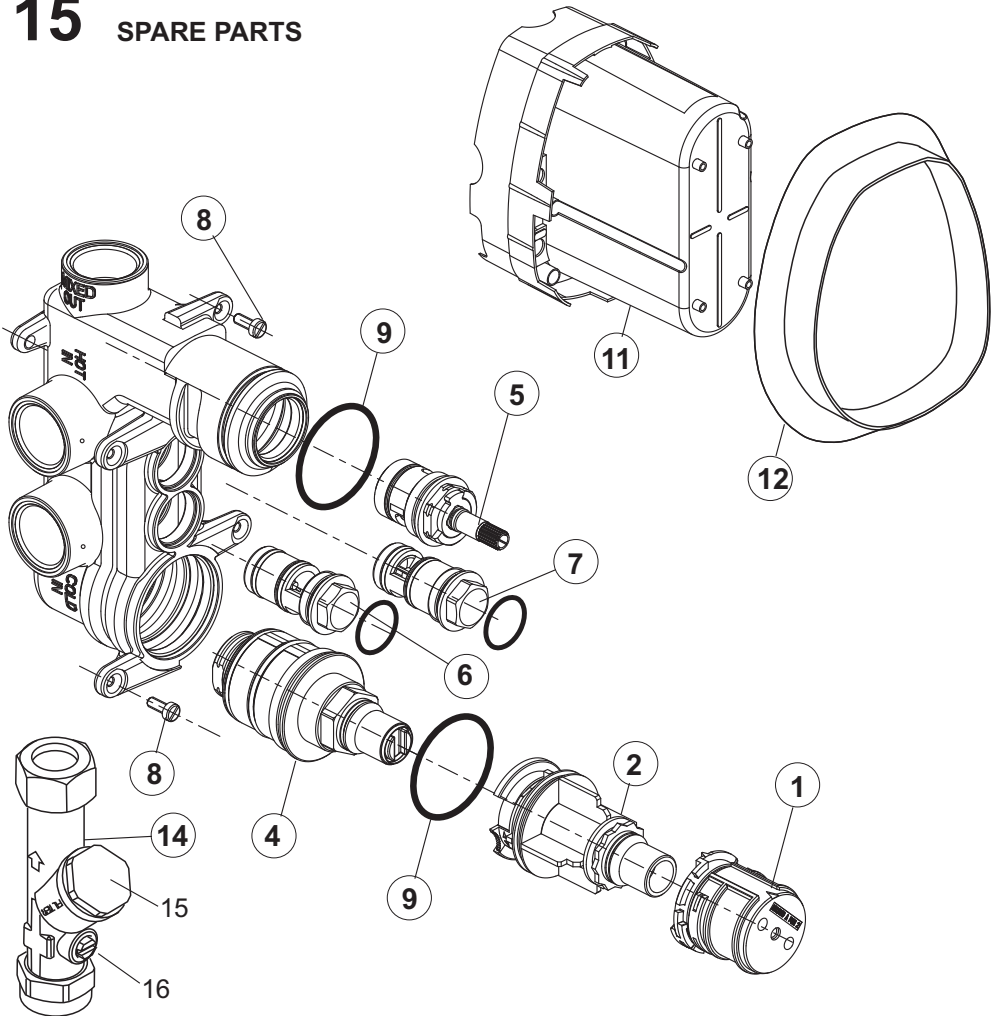

Figure 15 Exploded view of valve and associated components

Ref. Description

- 1 Temperature adjustment carrier
- 2 Temperature handle extension
- 4 Thermostatic cartridge
- 5 Flow control cartridge
- 6 Check valve - cold
- 7 Check valve - hot
- 8 Plaster guard screw

Ref. Description

- 9 O ring
- 11 Plaster guard
- 12 Tiling template (supplied with 2nd fix kit)
- 14 Isolating valve with strainer
- 15 Strainer cover
- 16 Isolating valve (shown closed)



09/11 E 96549000 40
(+A865612)

Ideal Standard International BVBA
Chaussée de Wavre, 1789 - box 15
1160 Bruxelles
Belgium

www.idealstandardinternational.com

2 GENERAL

The fittings covered by this installation and maintenance instruction should be installed in accordance with the water regulations published in 1999*, therefore, Ideal Standard would strongly recommend that these fittings are installed by a professional installer

*A guide to the Water Supply (Water Fittings) Regulations 1999 and the Water Byelaws 2000, Scotland, is published by WRAS (Water Regulations Advisory Scheme) Fern Close, Pen-y-Fan Industrial Estate, Oakdale, Newport, NP11 3EH. ISBN 0-9539708-0-9

The second fix kits detailed in the following pages are designed to be installed with the valves listed below.

TT Valve Dual Control First Fix Kit	A3969NU Ins. Ref. No.	E96549000
TT Central Valve First Fix Kit	A3970NU Ins. Ref. No.	E96549100
Stop Valve	A4860AA Ins. Ref. No.	E96549100

Instructions for installing the valves are packed with them but further copies can be obtained from Customer Care (see back cover for contact details) quoting the reference numbers above.

KURVE PARTS

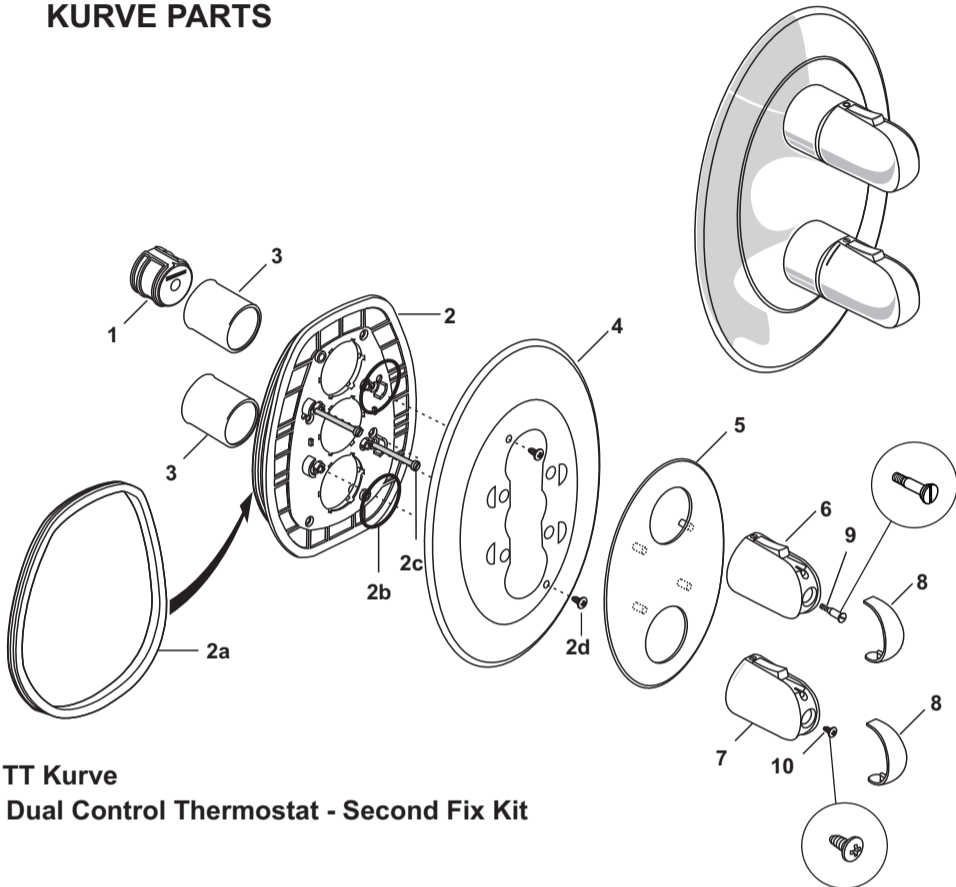

TT Kurve
Dual Control Thermostat - Second Fix Kit

3 OPOSTA PARTS

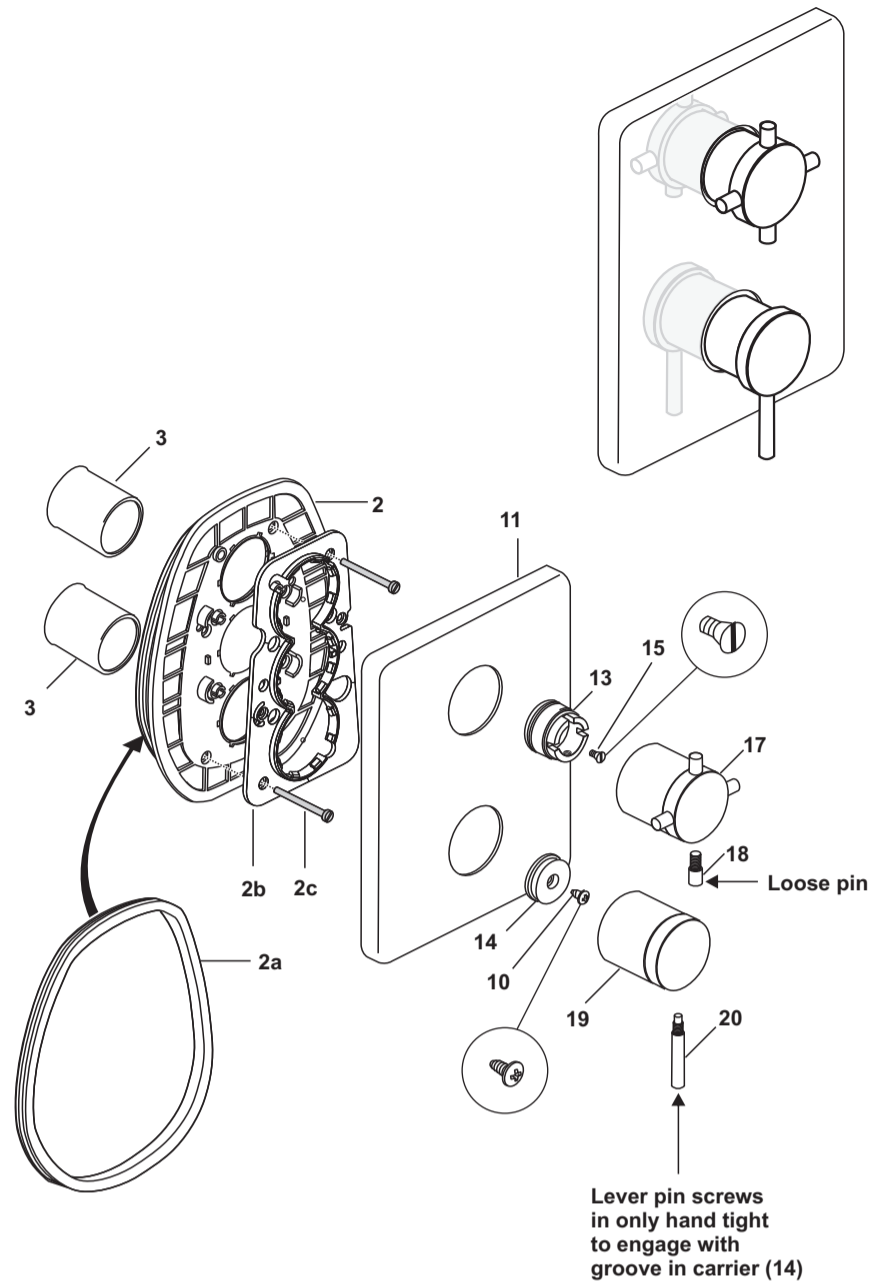

TT Oposta
Dual Control Thermostat - Second Fix Kit

4 ASCARI PARTS

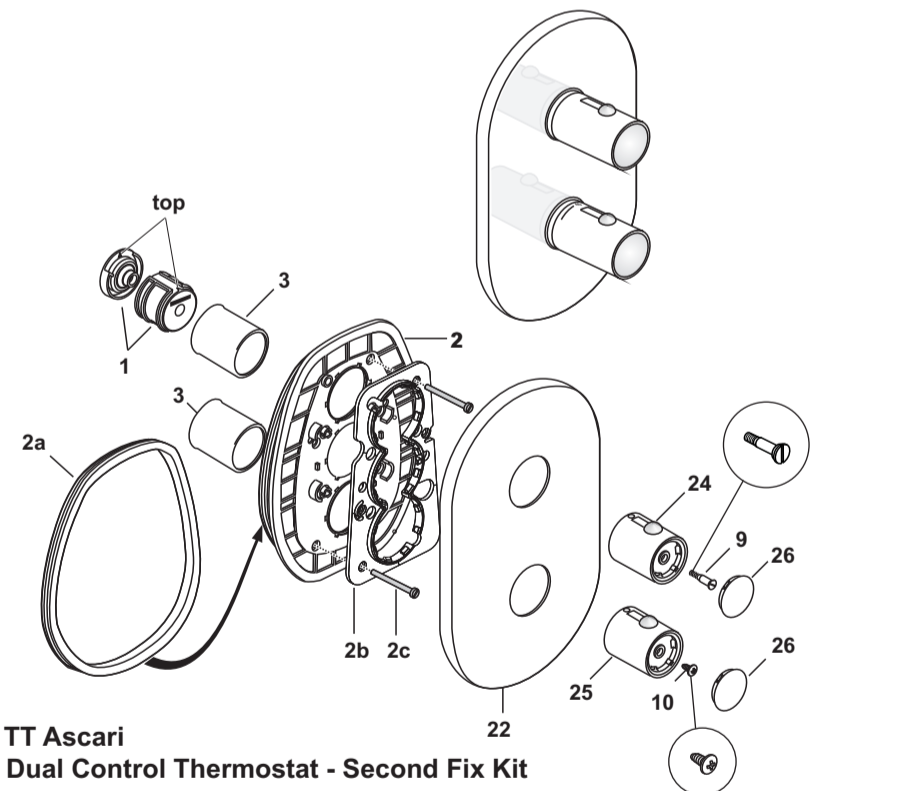

TT Ascari
Dual Control Thermostat - Second Fix Kit

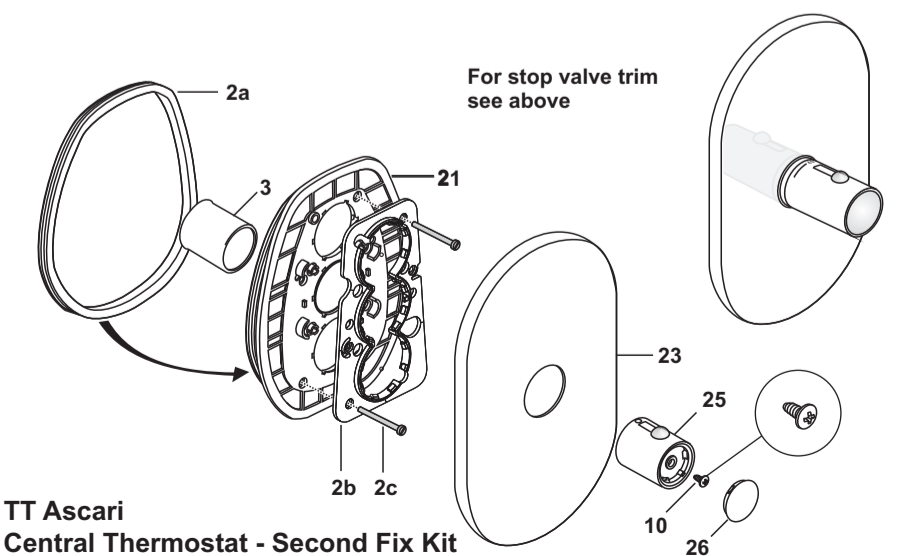

TT Ascari
Central Thermostat - Second Fix Kit

5 RIVAGE PARTS & FLOW CONTROL STOP

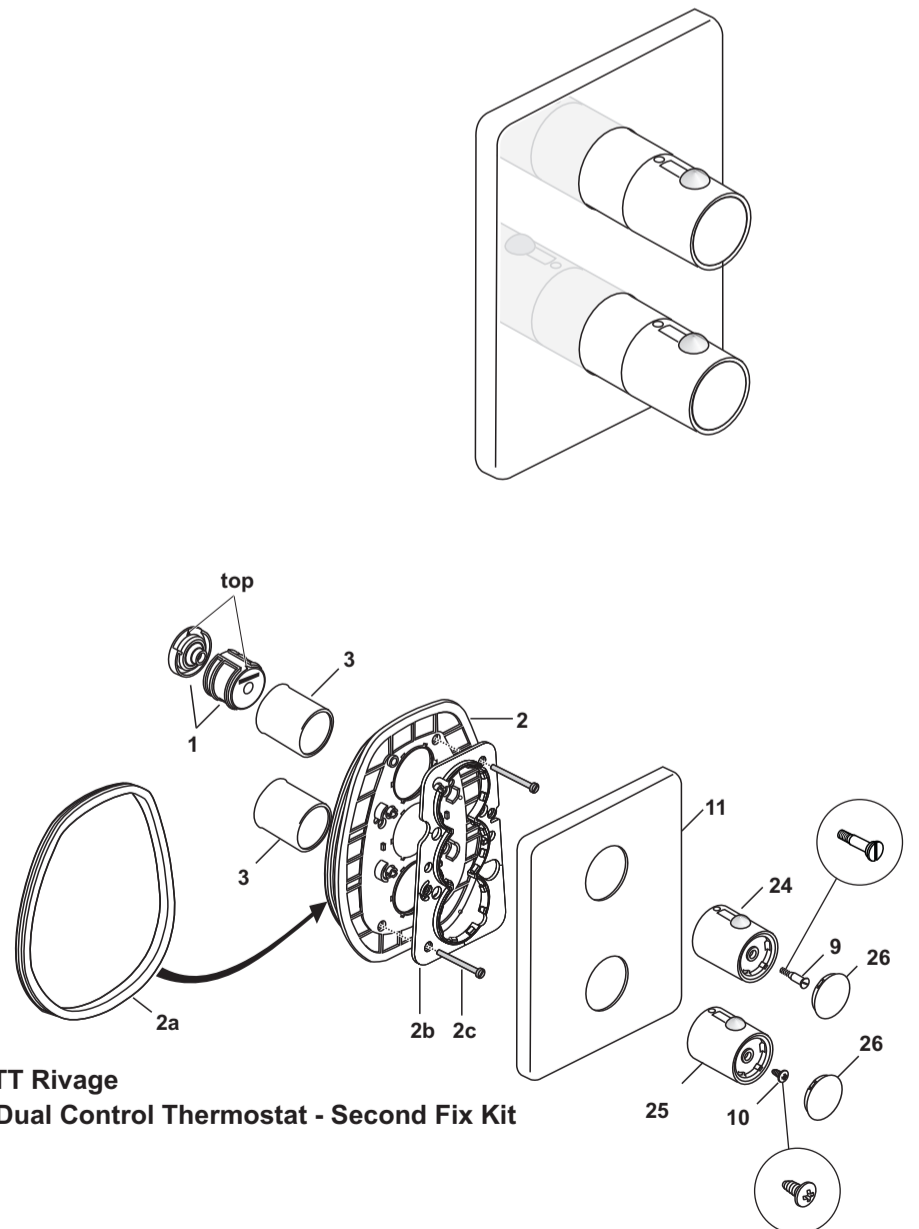

TT Rivage
Dual Control Thermostat - Second Fix Kit

6 TILING WITH THE TEMPLATE

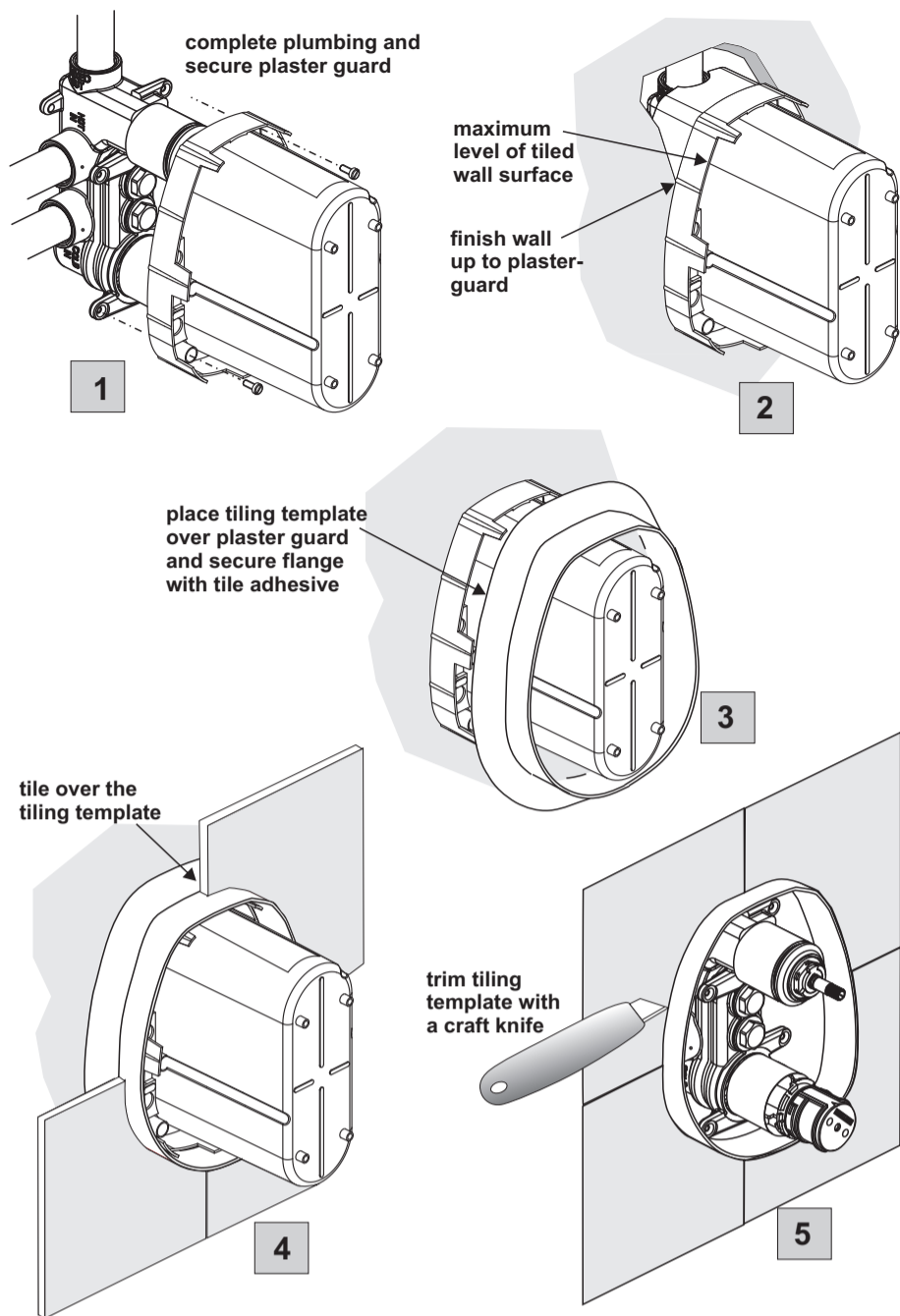

7 FITTING THE FACEPLATES

The TT Valve should be fitted as recommended in the leaflet packed with it. For completeness some of the guidance for making good the wall is repeated here.

1. Place the plaster guard over the valve body and fix in position using the screws provided.
2. Make good the wall up to the plaster guard.
3. Push the tiling template over the plaster guard and attach to the wall using tile adhesive.
4. Complete the tiling, trimming the tiles around the tiling template as shown
5. Trim the tiling template back to the tiled wall surface using a craft knife and de-burr the inside edge of the template to permit a good lead-in for the back plate seal.

6. Ensure the shrouds are fitted to the valve body. Push the back plate, with its seal attached, into the tiling template until it touches the tiled wall surface, ensuring that the o-rings slide smoothly over the shrouds (if necessary these may be lubricated with water containing a little washing up liquid) and secure using the two screws provided.

7. Push the face plate onto the back plate so that the four pins on the face plate engage in the sprung bosses of the backplate.

For the Kurve where the faceplate is in two parts, place the rear faceplate over the bosses and secure using the two self tapping screws then fit the face plate trim as above.

Attach the handles using the screws provided and snap the covers in place.

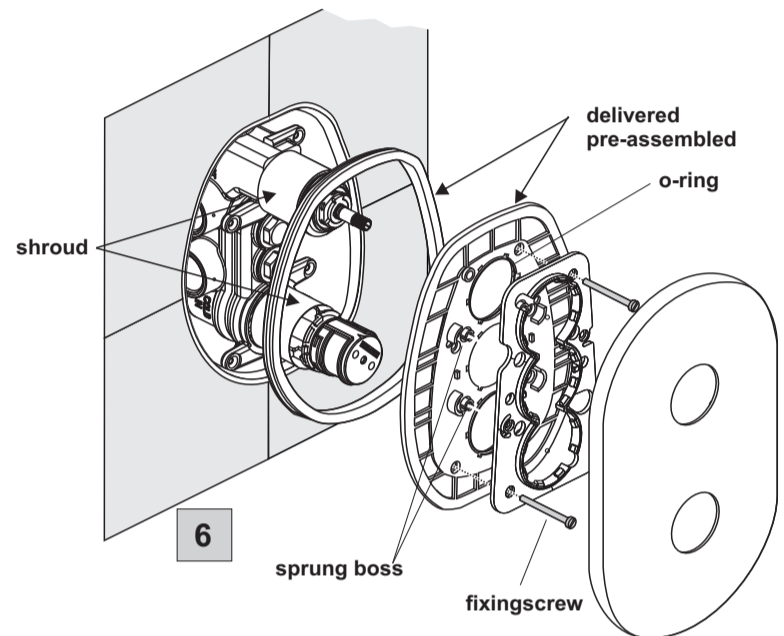

8 PARTS

Ref.	Description	Ref.	Description
1	Flow control handle carrier	11	Oposta/Rivage faceplate
2	DC escutcheon holder	13	Oposta flow handle carrier
2a	Gasket escutcheon holder	14	Oposta temp handle carrier
2b	Escutcheon holder small	15	Screw for flow handle carrier
2c	Screws for plastic back plate	17	Oposta flow handle
3	Shrouds	18	Oposta flow handle loose pin
4	Rear faceplate	19	Oposta temp handle
5	Faceplate trim	20	Oposta temp handle loose pin
6	Kurve flow control handle	21	CT escutcheon holder
7	Kurve temperature handle	22	Ascari DC faceplate
8	Kurve handle cover cap	23	Ascari CT faceplate
9	Flow handle screw	24	Ascari/Rivage flow handle
10	Temperature handle screw	25	Ascari/Rivage temp handle
		26	Ascari/Rivage handle cap

CLEANING

When cleaning the shower valve always use soap based cleaners. Never use abrasive or scouring powders and never use cleaners containing alcohol, ammonia, nitric acid, phosphoric acid or disinfectants.

TT VALVE

THERMOSTATIC SHOWER VALVE SECOND FIX KITS



Installation Instructions

- A3973 TT Kurve DC Second Fix Kit
- A3974 TT Oposta DC Second Fix Kit
- A3971 TT Ascari DC Second Fix Kit
- A3972 TT Rivage DC Second Fix Kit
- A3975 TT Ascari Central Second Fix Kit

INSTALLER:
After installation please pass this instruction booklet to the user

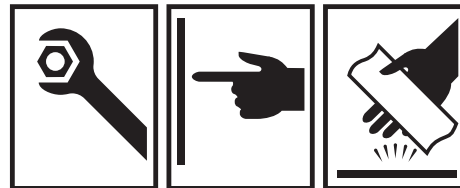
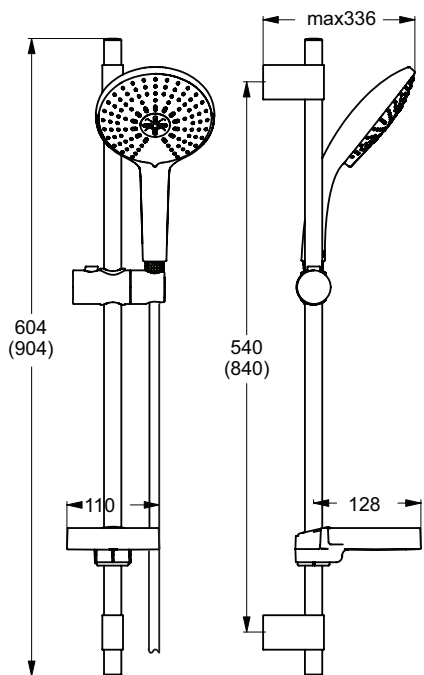
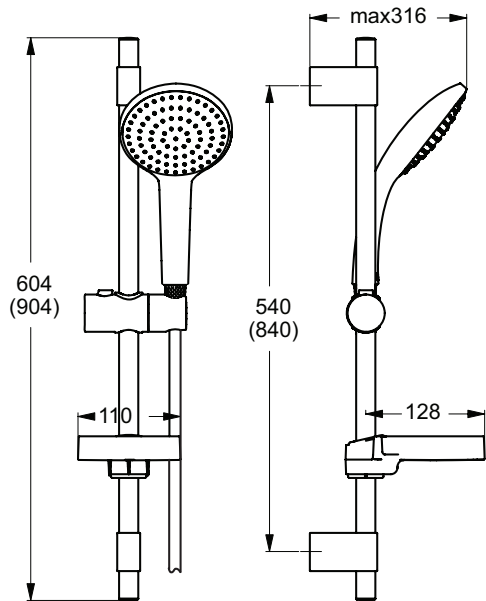

Ideal STANDARD

BG

Ideal Standard International
Ideal Standard-Vidima AD
53, Marin Popov str.
5400 Sevlievo, Bulgaria
Tel.: +359 675 30 368
Fax: +359 675 30 814

EU

Ideal Standard International BVBA
Chaussée de Wavre 1789, Box 15
1160 Brussels
Belgium
<http://www.idealstandardinternational.com>

D

Ideal Standard GmbH
Deutschland
Euskirchener Str. 80
53121 Bonn
Tel.: +49-(0)228-521-0
Fax: +49-(0)228-521-241

UK

Ideal Standard (UK) Ltd
The Bathroom Works
National Avenue
Kingston upon Hull
HU5 4HS
England
Tel.: +44 01482 346461
Fax: +44 01482 445886

F

Ideal Standard France
165, Av. du Bois de la Pie Bâtiment H
Parc des Reflets
95920 Roissy CDG
Tel.: +33 1 49 38 28 00
Fax: +33 1 49 38 28 28

I

Ideal Standard Italia S.r.l.
Via Domodossola, 19-
20145 Milano
Tel.: +39 800 652290
(toll-free number)

NL

Ideal Standard Nederland BV
L.J.Costerstraat 30
Postbus 7
5900 AA Venlo
Tel.: +31 (0)77 355 08 08
Fax: +31 (0)77 354 21 86

E

Ideal Standard,
S.L.Spain
Sant Martí, s/n
08107 Martorelles (Barcelona)
Tel.: +34 93 561 80 00
Fax: +34 93 570 63 12

PT

Ideal Standard Portugal
Nogueira - Ap4
4711-909 Braga
Portugal
Tel.: +351 253683141
Fax: +351 253683186

GR

Ideal Standard Greece
S.A.265, Mesogeion Ave.
N.Psychiko - 15451
Athens - Greece
Tel.: +30 210 6790800
Fax: +30 210 6790890

RU

Ideal Standard RUS
31-G, Shabolovka st
115998 Moscow Russia
Tel. +7 495 669 29 11
Fax: +7 495 669 23 12

UA

Ideal Standard International
Representative Office in Ukraine
89 Saksaganskogo str., KV.1
01032 Kiev, Ukraine
Tel./Fax: +380 44 537 32 72

BeLux

Ideal Standard Produktions-GmbH
Ikaroslaan 18
1930 ZAVENTEM / Belgium
Tel.: +32 (0)2 325 66 00
Fax: +32 (0)2 325 66 01

TR

Ideal Standard Türkiye
Şerif Ali Çiftliği Yan Yol Bölgesi,
Bayraktar Bulvarı, Miraç Sokak,
No:55 Ümraniye/İstanbul
Tel: 0216 3148787
Fax: 0216 4998357

CZ

Ideal Standard a.s.
Česká republika
Zemská 623
415 74 Teplice
Tel.: +420 417 59 21 11
Fax: +420 417 56 07 72

