

mira

SHOWERS

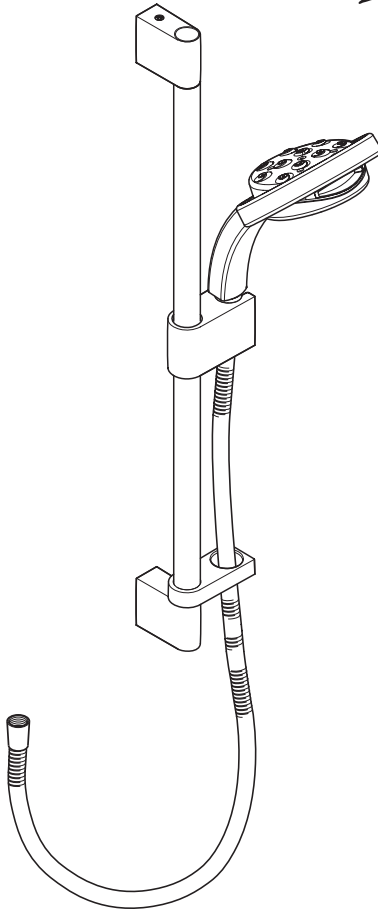

With **Flipstream** Technology
1flip action, 4 unique sprays

CLASSIC

SHOWER FITTINGS

Installation and User Guide

These instructions are to be left with the user

CONTENTS

Introduction	3
Important Safety Information	3
Guarantee.....	4
Guarantee	4
Patents and Design Registration.....	4
Pack Contents	5
Dimensions	6
Specifications	7
Pressures	7
Installation Requirements	7
Installation	8
Operation	10
Maintenance.....	12
Fault Diagnosis.....	13
Spare Parts	14
Notes	15
Customer Service.....	16

INTRODUCTION

Thank you for purchasing a quality Mira product. To enjoy the full potential of your new product, please take time to read this guide thoroughly, having done so, keep it handy for future reference.

Classic Shower Fittings

An adjustable Showerhead with four different spray actions (rain, cloud, storm and burst), supplied complete with Shower Hose, Clamp Bracket, Slide Bar Supports, and a Hose Retaining Ring.

These shower fittings are designed for use with all Mira products.

Available in chrome finish.

IMPORTANT SAFETY INFORMATION

Warning!

1. Products manufactured by us are safe and without risk provided they are installed, used and maintained in good working order in accordance with our instructions and recommendations.

Caution!

1. Read all of these instructions.
2. Retain this guide for later use.
3. Pass on this guide in the event of change of ownership of the installation site.
4. Follow all warnings, cautions and instructions contained in this guide.
5. Anyone who may have difficulty understanding or operating the controls of any shower should be attended whilst showering. Particular consideration should be given to the young, the elderly, the infirm, or anyone inexperienced in the correct operation of the controls.
6. When this product has reached the end of its serviceable life, it should be disposed of in a safe manner, in accordance with current local authority recycling, or waste disposal policy.

If you experience any difficulty with the installation or operation of your new Shower Fittings, please refer to '**Fault Diagnosis**', before contacting Kohler Mira Ltd. Our telephone and fax numbers can be found on the back cover of this guide.

GUARANTEE

Guarantee

For **domestic installations**, Mira Showers guarantee the Mira Classic Shower Fittings against any defect in materials or workmanship for a period of one year from the date of purchase

For **non-domestic installations**, Mira Showers guarantee the Mira Classic Shower Fittings against any defect in materials or workmanship for a period of one year from the date of purchase.

For terms and conditions refer to the back cover of this guide.

Patents and Design Registration

Patent Applications:

UK: 0715612.8, 0804172.5

World: PCT/GB2008/002703

Design Application:

EU: 001004022

PACK CONTENTS



Tick the appropriate boxes to familiarise yourself with the part names and to confirm that the parts are included.

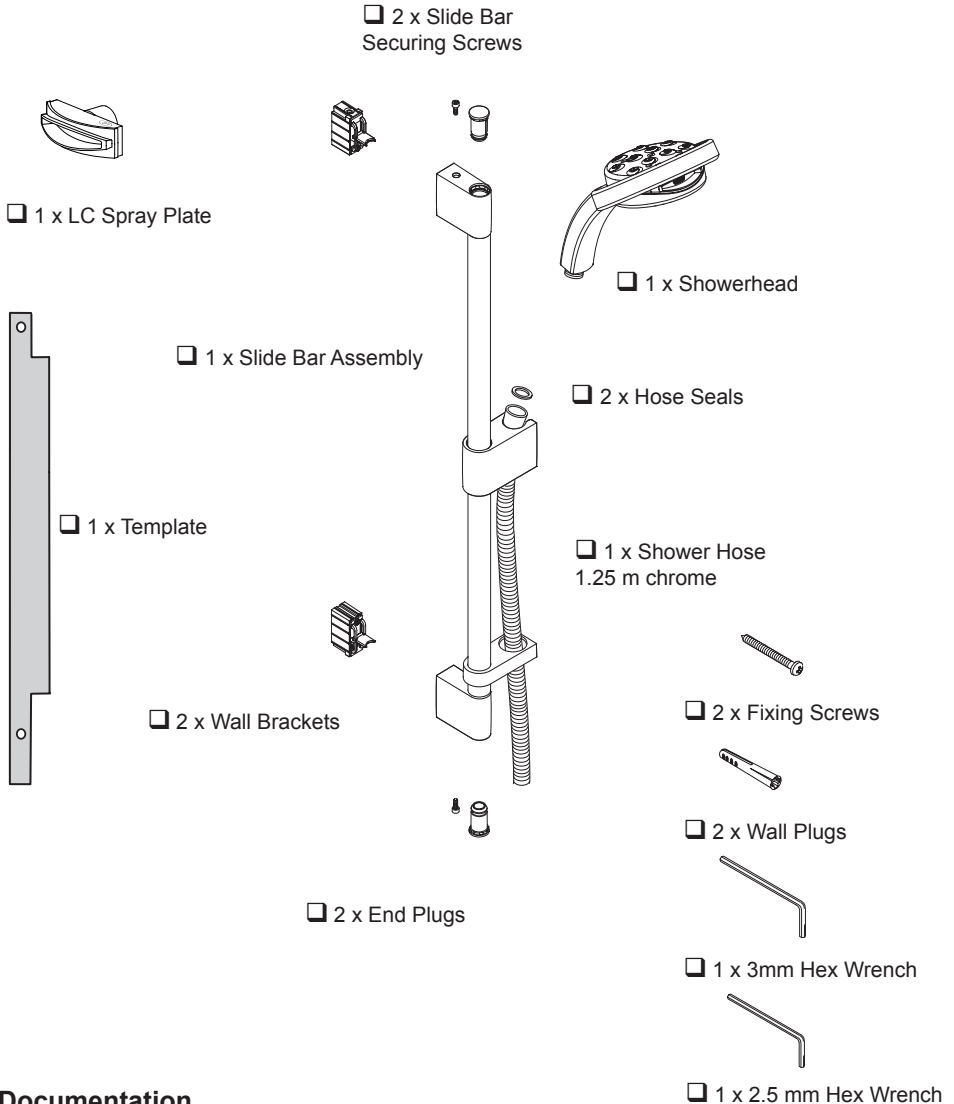

DIMENSIONS

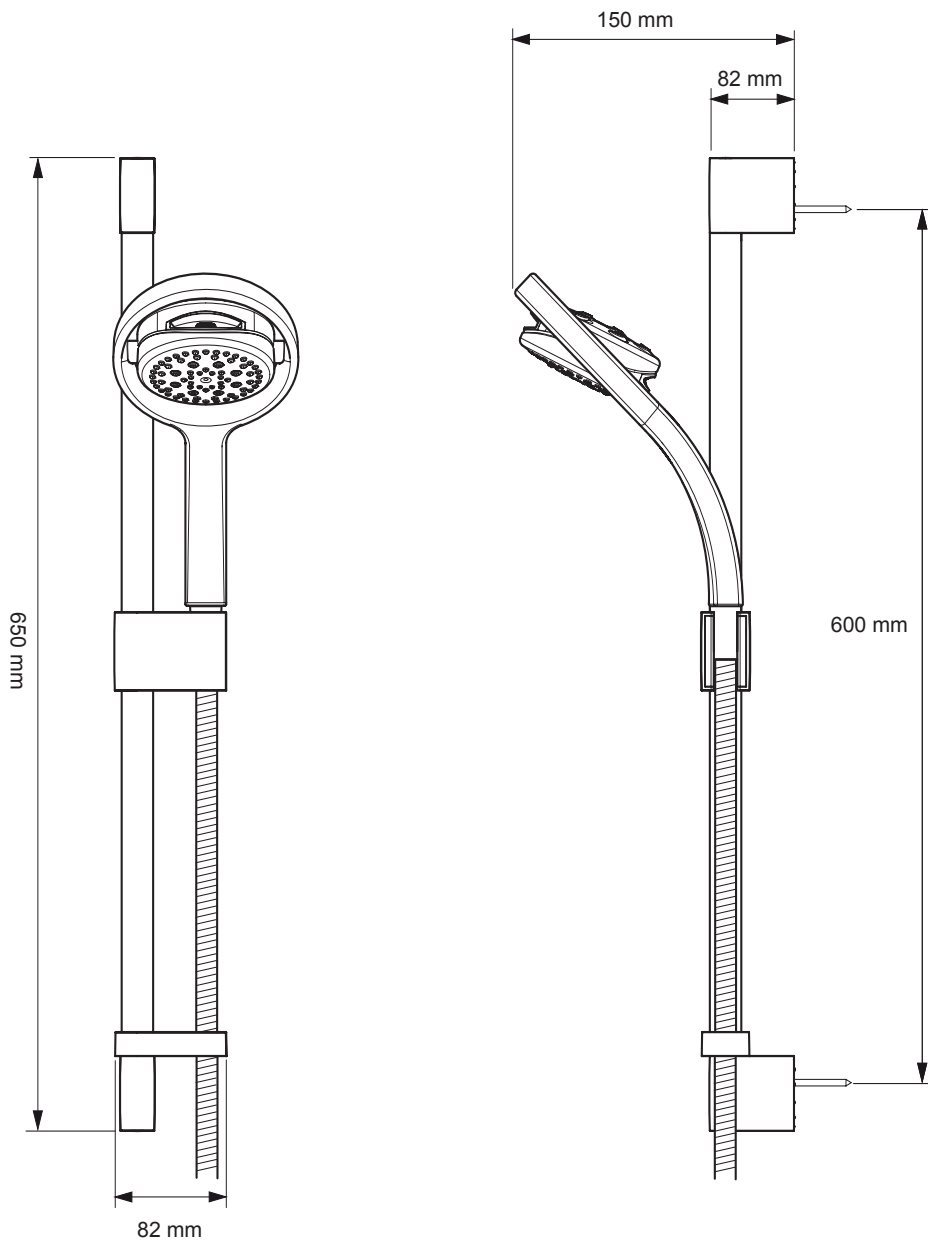

SPECIFICATIONS

Pressures

Minimum maintained pressure: **0.1 bar** (10 kPa).

Maximum maintained pressure: **5.0 bar** (500 kPa).

Warning! Exceeding the stated maximum maintained pressure could result in excessive spray forces and possible damage to the product.

INSTALLATION REQUIREMENTS

Installation must be carried out in accordance with these instructions, and must be conducted by designated, qualified and competent personnel.

1. The hose retaining ring supplied **must** be used to stop the showerhead from dropping below the spill-over level of the bath or shower tray, ensure there is a minimum of 25mm between the showerhead and bath/tray spill-over level. This will prevent water supply contamination due to back-siphonage.
2. Installations **must** comply with UK Water Regulations/ Bye-laws (Scotland), and Building and Plumbing Regulations in force at the time of installation
3. When installing the shower fittings in a cubicle, position with the spray pointing across rather than toward the opening of the cubicle.
4. When installing the shower fittings over a bath, position with the spray pointing down the centre line of the bath.
5. Avoid layouts where the shower hose will be sharply kinked. This may reduce the life of the hose.
6. **Do not** fit any form of flow control in the shower outlet.
7. **Do not** use excessive force when making connections.
8. **Do not** install the fittings in a position where it could become frozen.

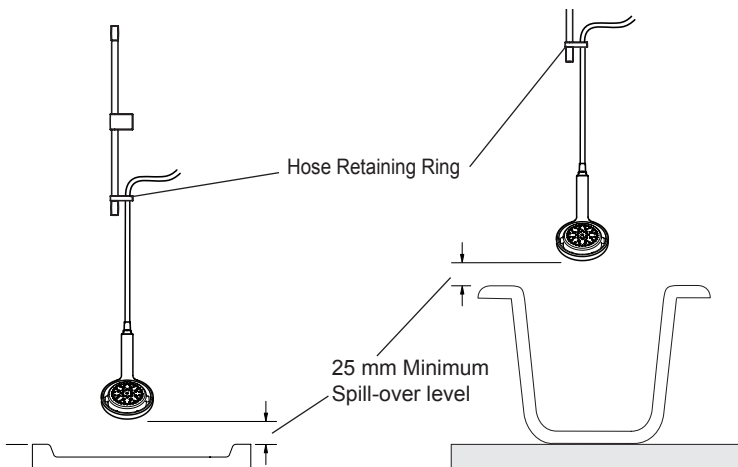

INSTALLATION

Note! For dry lined, stud partition, shower cubicle or laminated panel walls the installer may wish to obtain alternative proprietary cavity fixings. Use of these alternative fixings is beyond the scope of this guide.

Read the section: **Installation Requirements** before proceeding with the installation.

The slide bar should be positioned to one side of the shower control at a convenient height for all the family. It should be positioned so that the showerhead discharges down the centre line of the bath, or across the opening of the shower cubicle. The showerhead should be directed away from the shower control.

1. Decide on a suitable position for the slide bar avoiding buried cables and pipes.
2. Using the supplied template as a guide, mark the position of the fixing holes for the wall brackets.

Note! Use a spirit level to make sure that the fixing holes are vertical.

Drill the two $\text{Ø}8$ mm fixing holes for the wall brackets at 600 mm centres, and insert the wall plugs.

3. Insert the fixing screws through the holes in the wall brackets, screw them to the wall but do not fully tighten them at this stage. Use the template to set the correct distances between the brackets then fully tighten the screws.

Note! Slots in the wall brackets allow for minor adjustment, use one horizontal and one vertical slot for fixing.

Note! Make sure that the holes for the slide bar securing screws are positioned correctly, refer to the illustration.

4. Position the slide bar over the wall brackets and secure with the slide bar securing screws as indicated.
5. Fit the end plugs into the slide bar supports and push firmly with thumb or finger to until it clicks into place.

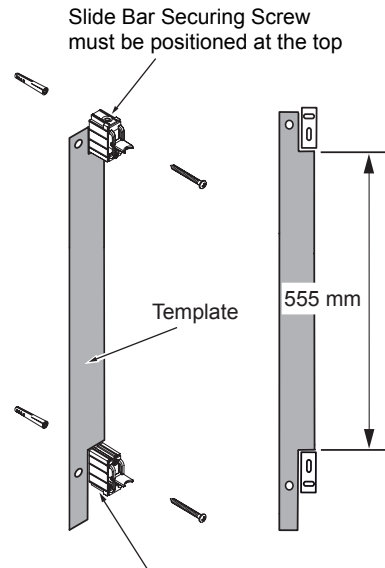

Slide Bar Securing Screw must be positioned at the bottom

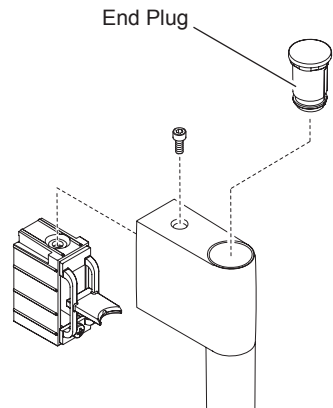

- Screw the shower hose onto the showerhead and the outlet of the shower (Make sure the hose seals are fitted). **Do not overtighten.**
- Place the showerhead into the clamp bracket and adjust its height as desired.

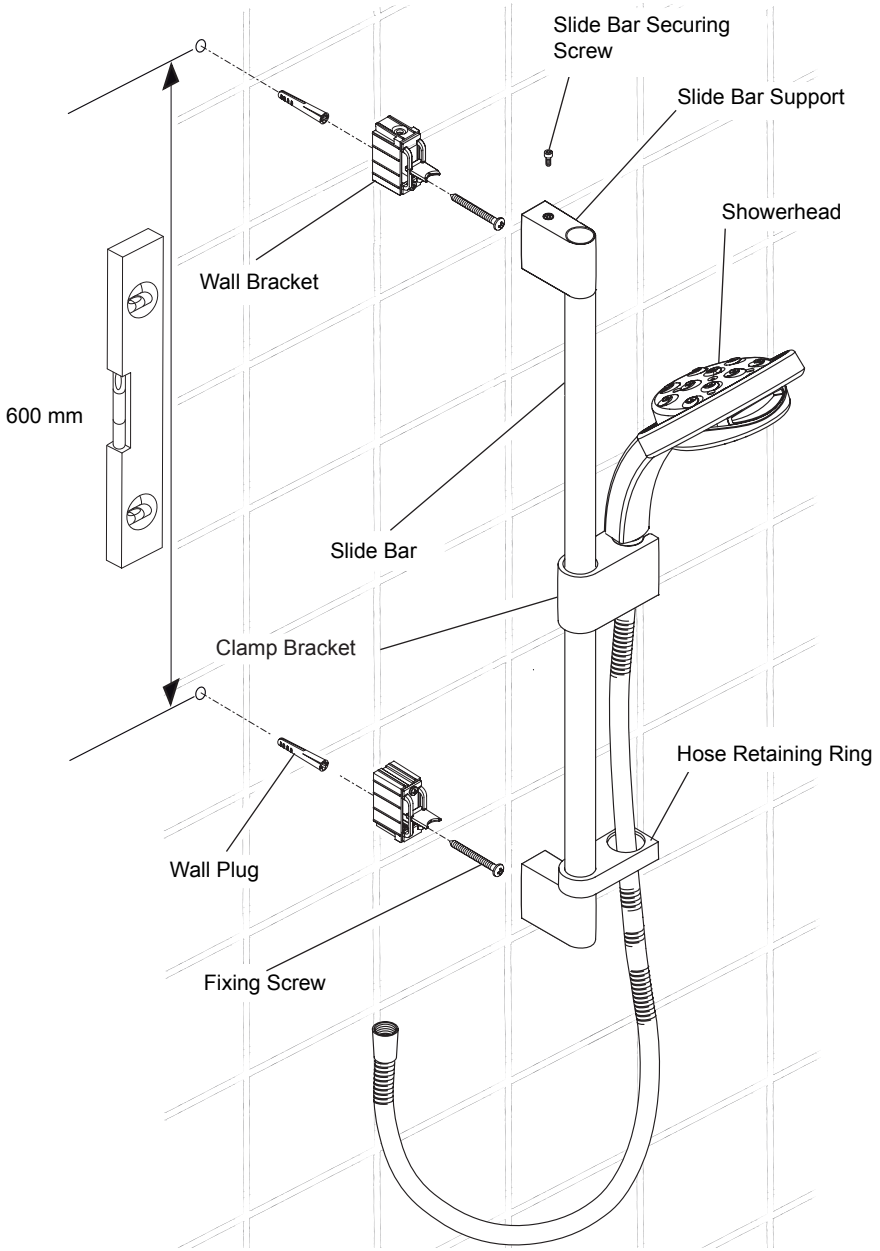

OPERATION

Changing the Spray Setting

The Classic Showerhead has four different spray actions:- Rain, Cloud, Storm and Burst. The showerhead features a rotating head to enable differing spray patterns to be achieved, turn the showerhead in the direction shown to activate the different spray patterns.

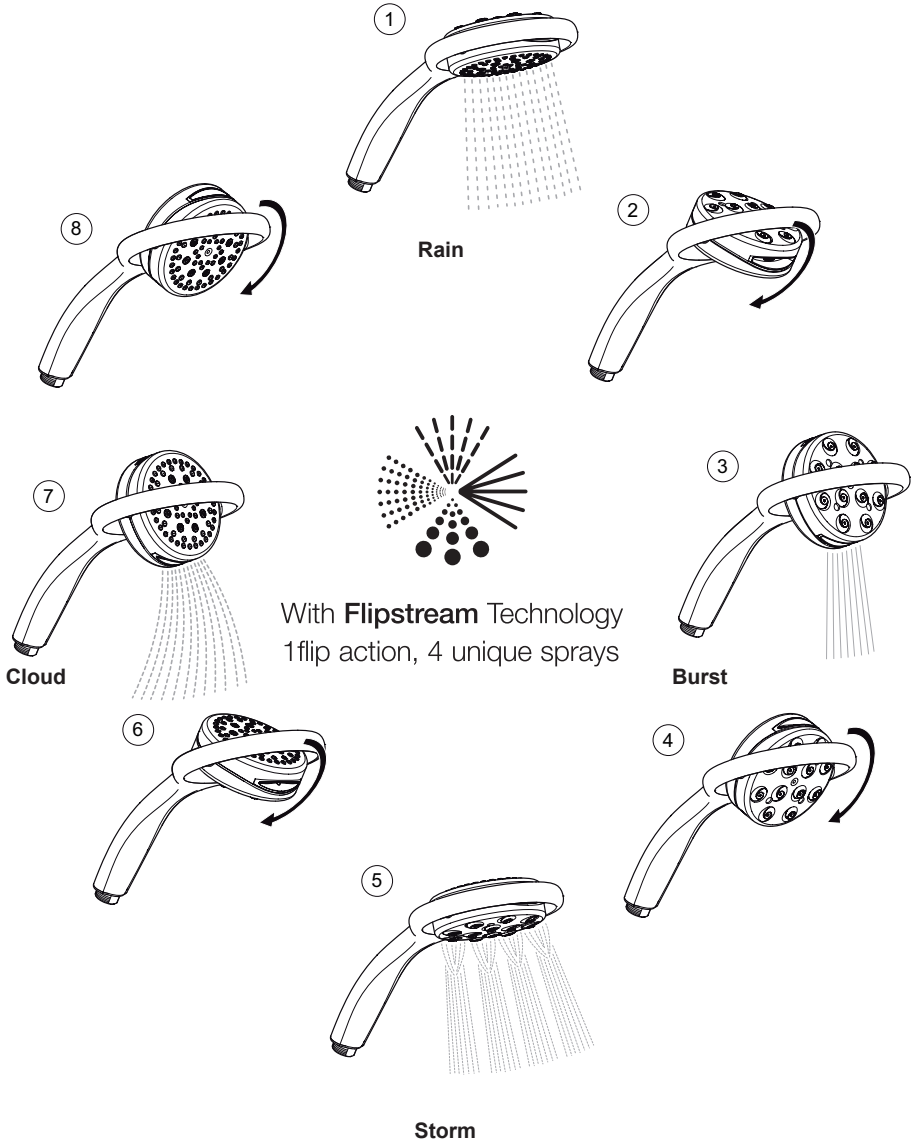

Height Adjustment.

The height of the showerhead is easily adjusted by gently moving the clamp bracket either up or down the slide bar until the required height is achieved.

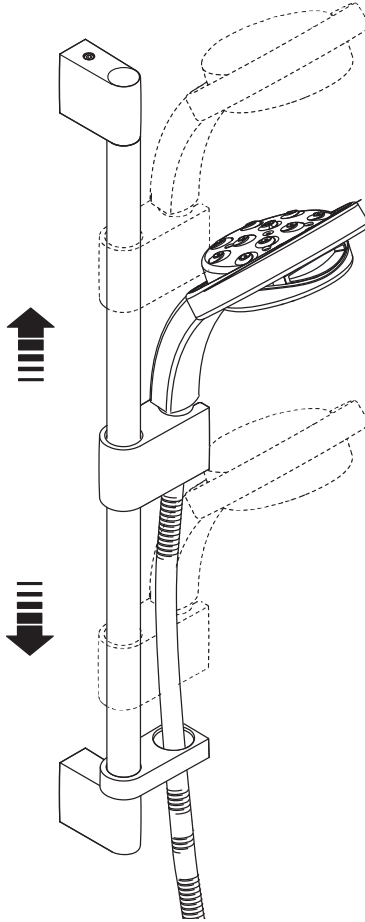

MAINTENANCE

Cleaning

Many household cleaners contain abrasives and chemical substances, and should not be used for cleaning plated or plastic fittings. These finishes should be cleaned with a mild washing up detergent or soap solution, and then wiped dry using a soft cloth.

Spray Plate Assembly - External

1. Use your thumb or a soft cloth to wipe any limescale from the soft rubber nozzles and the front face of the spray plate assembly **Important!** The sprayplate must be regularly cleaned to make sure that the handset does not become blocked..

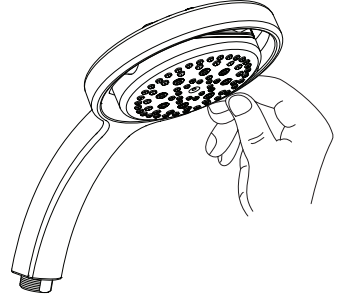

Cloud Spray Plate Assembly

This product is supplied configured for the majority of showering systems including electric showers.

Note! For showers with a pressure of below 0.15 bar (1.5 metre head) it will be necessary to change the Cloud sprayplate assembly for the LC (Low Capacity) version to achieve a suitable spray pattern.

Caution! The LC sprayplate **must not** be used on electric showers

1. Use a suitable tool to remove the grommets.
2. Using the 2.5 mm hexagonal wrench (supplied), remove the screws.
3. Separate the sprayplate assembly into its individual components.
4. Replace the Cloud assembly sprayplate with the LC version.
5. Reassemble the components in reverse order.

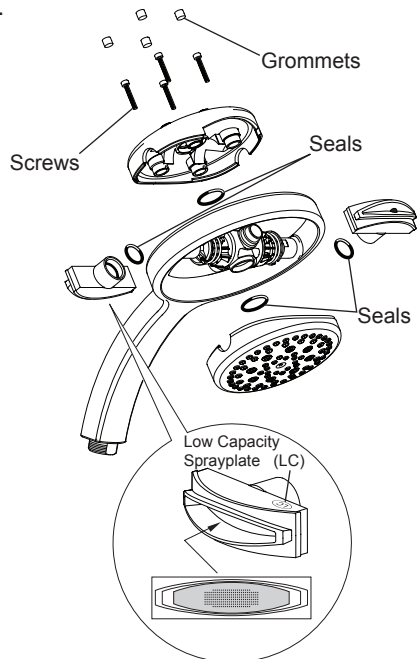

FAULT DIAGNOSIS

The trouble shooting information tabled below gives details on what you can do as a user, should you encounter difficulties with the shower fittings whilst operating the shower. Before replacing any parts make sure that the underlying cause of the malfunction has been resolved.

Malfunction	Cause	Remedy
No flow or low flow rate from shower fittings.	Spray plate blocked. Hose blocked or twisted. Problem with shower control.	Refer to section 'Maintenance, Cleaning' . Clear blockage or release twist in hose or renew hose. Refer to the shower control Installation and User Guide.
Drip from spray plate assembly in Showerhead.	A small amount of water may be retained in the shower fitting after the shower control has been turned off. This may drain over a few minutes.	This is quite normal. Changing the angle of the showerhead may vary the draining time.
Shower temperature changes when spray action is adjusted.	Adjusting the spray action changes the flow of water. This may affect some shower controls and plumbing installations.	To minimise the effect make sure that the spray plate is clean. Refer to section: 'Maintenance, Cleaning' . If the malfunction persists refer to the shower control Installation and User Guide.
Poor spray pattern from the Cloud Sprayplate assembly		Change the Cloud sprayplate for the LC (Low Capacity) version. Refer to section 'Maintenance Cloud LC Spray Plate Assembly'

SPARE PARTS

- 575.09 Hexagonal Wrench - 3 mm
- 575.12 Hexagonal Wrench - 2.5 mm (not illustrated)
- 632.73 Hose Seal (x2)
- 1603.104 Shower Hose 1.25m chrome
- 1688.160 360m/i/r - Rain Assembly - white
- 1688.162 360m/i/r -Storm Assembly - white
- 1688.164 360m/i/r -Cloud Assembly - white
- 1688.166 360m/i/r -Burst Assembly - white
- 1688.168 360m/i/r -Seal & Screw Pack - components identified 'B'
- 1688.185 Classic Clamp Bracket - chrome
- 1688.187 Classic Slide Bar Support - chrome
- 1688.188 Classic Hose Retaining Ring - chrome
- 1688.190 Classic fitting component pack 'A' (including wall plugs and screws)
- 1688.193 Classic Slide Bar
- 1688.200 360m Showerhead - chrome/white
- 1688.275 360m/i/r - Cloud Assembly LC (Low Capacity) - white

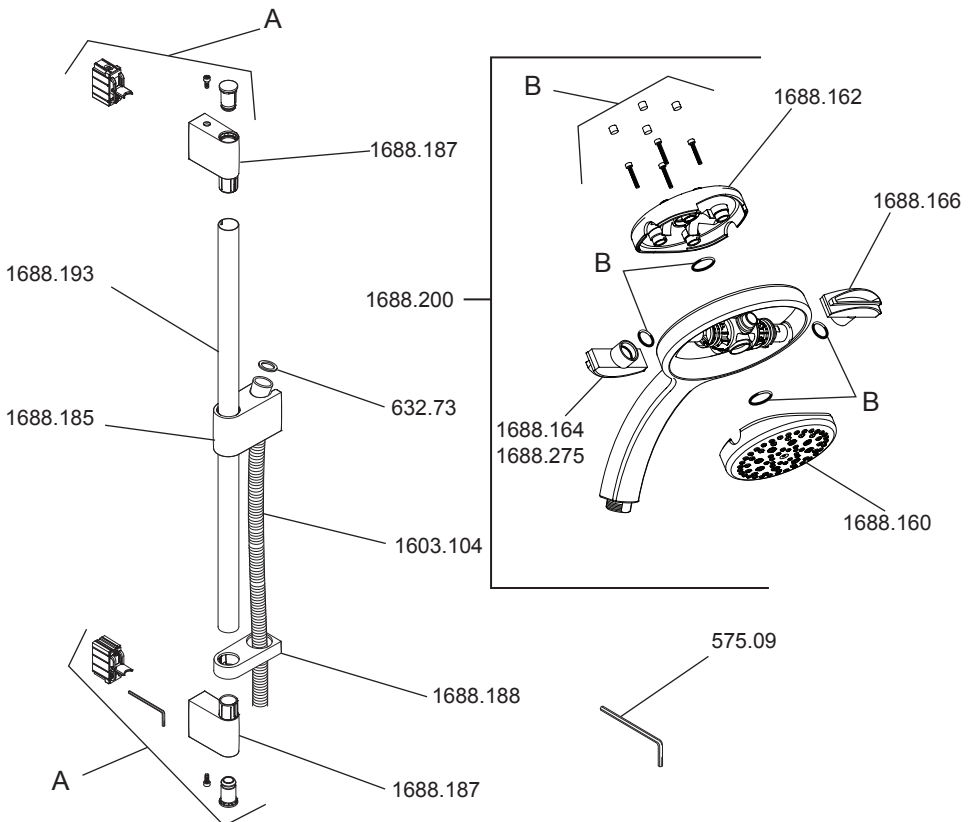

NOTES

CUSTOMER SERVICE

Guarantee of Quality

Mira Showers guarantee your product against any defect in materials or workmanship, provided that it is installed and maintained in accordance with the instructions given in this guide.

To validate the guarantee, please return your completed registration card within 30 days of product installation.

Within the guarantee period we will resolve defects, free of charge, by repairing or replacing parts or modules as we may choose.

To be free of charge, service work must only be undertaken by Mira Showers or our approved agents.

Service under this guarantee does not affect the expiry date of the guarantee.

The guarantee on any exchanged parts or product ends when the normal product guarantee period expires.

Not covered by this guarantee:

Planned maintenance, or replacement parts required to comply with the servicing requirements of the TMV 2 and TMV 3 healthcare schemes (where applicable).

Damage or defects arising from incorrect installation, improper use or lack of maintenance, including build-up of limescale.

Damage or defects if the product is taken apart, repaired or modified by any persons not authorised by Mira Showers or our approved agents.

This guarantee is in addition to your statutory and other legal rights.

What to do if something goes wrong

If when you first use your shower, it doesn't function correctly, first contact your installer to check that installation and commissioning are satisfactory and in accordance with the instructions in this manual. We are on hand to offer you or your installer any advice you may need.

Should this not resolve the difficulty, simply contact our Customer Services Team who will give every assistance and, if necessary, arrange for our service engineer to visit. If the performance of your shower declines, consult this manual to see whether simple home maintenance is required. Please call our Customer Services Team to talk the difficulty through, request a service under guarantee if applicable, or take advantage of our comprehensive After-Sales service.

As part of our quality and training programme calls may be recorded or monitored.

Our Customer Services Team is comprehensively trained to provide every assistance you may need: help and advice, spare parts or a service visit.

Spare Parts

We maintain an extensive stock of spares and aim to provide support throughout the product's expected life.

Genuine Mira spares can be purchased direct from Customer Services or from approved stockists or merchants (locations on request).

Spare parts will normally be despatched within two working days. Payment can be made using most major Credit or Debit cards at the time of ordering. Should payment by cheque be preferred, a pro-forma invoice will be sent.

All spares are guaranteed for 12 months from the date of purchase. Spares that have been supplied directly from us can be returned within one month from the date of purchase, providing that they are in good order and the packaging is unopened.

Note! Returned spares will be subject to a 15% restocking charge and authorisation must be obtained before return. Please contact our Customer Services Team.

Note! In the interests of safety, spares requiring exposure to mains voltages should only be fitted by competent persons.

Service / Repairs

Our Service Force is available to provide a quality service at a reasonable cost. You will have the assurance of a Mira trained engineer/agent, genuine Mira spare parts and a 12 month guarantee on the repair.

Payment should be made directly to the engineer/agent who will accept most major Credit or Debit cards or a cheque supported by a banker's card.

To Contact Us

England, Scotland, Wales and Northern Ireland

Mira Showers Customer Services

Telephone: 0870 241 0888

E-mail: technical@mirashowers.com

Fax: 01242 282595

By Post: Cromwell Road, Cheltenham, Gloucestershire, GL52 5EP

Eire

Modern Plant Ltd (Dublin)

Telephone: 01 459 1344

E-mail: sales@modernplant.ie

Fax: Dublin 01 459 2329

Post: Otter House, Naas Road, Clondalkin, Dublin 22

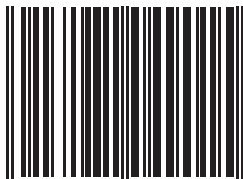

5 013181 049015 >

Mira is a registered trade mark of
Kohler Mira Limited.

The company reserves the right to alter
product specifications without notice.

www.mirashowers.co.uk

mira
SHOWERS



FM 14648