

Installation Instructions

IN-LINE THERMOSTATIC SHOWER VALVE

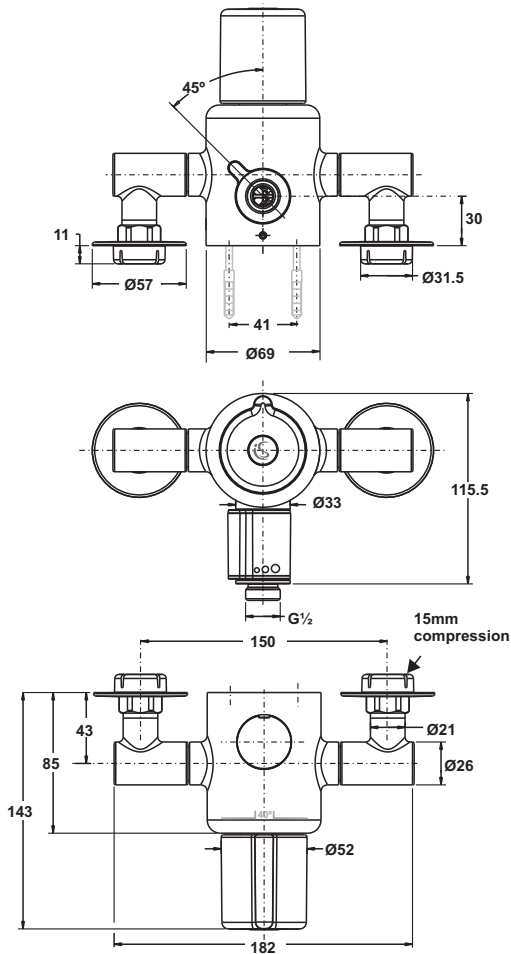

A5322AA In-line Thermostatic Shower Valve
A5525AA Second Outlet Kit
A5526AA Retro Fit Installation Kit

BEFORE CONNECTION FLUSH WATER THROUGH PIPEWORK TO REMOVE ALL GRIT & DEBRIS WHICH COULD DAMAGE THE VALVE MECHANISM

INSTALLER: *After installation please pass this instruction booklet to the user*

1

INTRODUCTION

The fittings covered by these instructions should be installed in accordance with the Water Regulations published in 1999*. Ideal Standard strongly recommends that these fittings are installed by a professional fitter.

*A guide to the Water Supply (Water Fittings) Regulations 1999 and the Water Byelaws 2000, Scotland is published by WRAS (Water Regulations Advisory Scheme) Fern Close, Pen-y-Fan Industrial Estate, Oakdale, Newport, NP11 3EH. ISBN 0-9539708-0-9

These thermostatic shower mixers are designed to be installed on normal UK low pressure storage tank fed systems, unvented high pressure systems, modulating instantaneous water heaters or modulating combination (combi) boilers. They are suitable for all pumped applications.

WATER REGULATIONS

Hot and cold water supply pressures must be reasonably balanced and from a common source - both from storage or both from a supply pipe. (IRN 101). The mixers will function within specification on unequal pressures up to a ratio of 5 : 1, but it is not recommended that the cold supply be connected to the rising main and hot to the tank fed supply as the pressure differential is likely to exceed the 5:1 ratio. **(See table 1)** The minimum pressure for correct operation is 0.1 bar (1m head). Pressure head is measured as the vertical distance between the bottom of the cold water storage tank which feeds the hot water system and the highest point on the shower spray plate. When installing with a shower pump the use of a secondary tapping from the cylinder is highly recommended.

Figure 1 shows the various methods of connecting the hot water pipe to the cylinder - the most preferred on the left and the least preferred on the right.

The fitting should be so installed as to be readily accessible for examination, repair, replacement or operation. (IRN 111).

The temperature of the hot water must not exceed 85°C but the installer's attention is drawn to code of practice BS 6700 which recommends that stored hot water should normally never exceed 65°C. For correct operation of the valve, a minimum of 55°C is required.

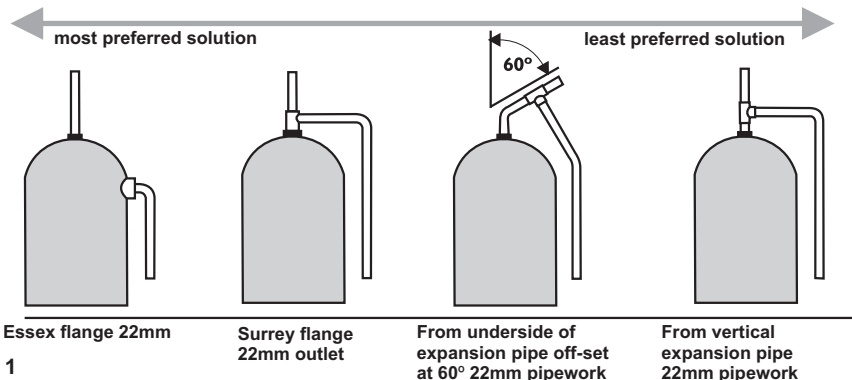

Figure 1 Preferred arrangements for cylinder tapping

2 SUPPLY CONDITIONS

Table 1 Conditions for normal use

| | BSEN1111 | BSEN1287 |
|--|----------------|----------------|
| Operating pressure range: | High Pressure | Low Pressure |
| Maximum static pressure - Bar | 10 | 10 |
| Flow pressure hot and cold - Bar | 0.5 to 5.0 | 0.1 to 1.0 |
| Hot supply temperature - °C | 55 to 65 | 55 to 65 |
| Cold supply temperature - °C | up to 25°C max | up to 25°C max |
| Temperature differential characteristic (TDC) °C | 10 | 10 |

FLOW RATE

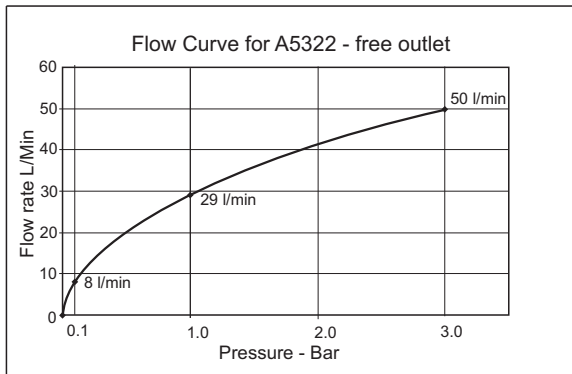

MODULATING COMBI BOILER

This thermostatic shower valve is designed for use with modulating combination boilers.

When installing on a modulating combination boiler it is sometimes possible for the interaction of a thermostatic valve with the combi to cause the boiler to cut out and cut in again. With the result that the water will become alternatively cold and hot. To overcome this, the 4 L/min flow regulator provided should be fitted upstream of the thermostatic valve. It should be fitted in any 15mm compression fitting in the dedicated cold supply pipe.

It is important to choose a compression fitting located in a position which is accessible after installation and it must be fitted the correct way round for the direction of flow (see fig2). The regulator can be fitted in either the inlet or outlet side of the compression fitting. If fitting in an outlet side, ensure the o-ring is seated fully in the visible rebate around the edge of the regulator. Use the tip of a small screwdriver or similar to achieve this. Ensure the tail of the pipe is not fouling the regulator (shorten if required) and do up the compression fitting as normal. In a minority of cases, where the boiler is of a type which stores a small quantity of very hot water, it may also be necessary to fit a 4 L/min flow regulator in the hot supply. These can be obtained from Customer Care (A962570NU)

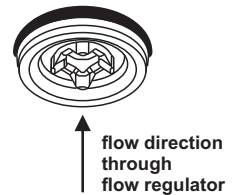

Figure 2

The fitting of isolation valves is required as close as is practicable to the water supply inlets of the thermostatic mixing valve.

The fitting of strainers is recommended as close as is practicable to the water supply inlets of the thermostatic mixing valve.

3 WATER REGULATIONS

CATEGORIES OF RISK

The water regulations published in 1999* take a new approach to backflow in that they look at different categories of risk. The installer must assess the risk from the various categories of fluid in adjacent appliances before determining the level of backflow protection required for a particular installation. Figures 3 & 4 describe the protection required in various installations.

CATEGORY 3 RISK

Water in a shower tray, basin or bathtub is considered to be a fluid category 3 risk which is a fluid which represents a slight health hazard if it were to find it's way back into the supply pipe. For this reason it must not be possible for any flexible shower head to be able to enter any adjacent washbasin, bath or shower tray unless appropriate protection is employed. (See Figure 3). If it is desired to allow the hand spray to be used inside say a bathtub or a basin it is essential that double check valves be fitted to the inlet on both hot and cold supplies to the thermostatic valve. Alternatively single check valves can be fitted at the inlets and an additional check valve should be fitted in the valve outlet.

No check valves need be fitted if the hand spray is prevented from reaching closer than 25mm of the spill over level of any such fixture.

CATEGORY 5 RISK

Water in a Sink, WC or Bidet is considered to be a fluid category 5 risk which is a fluid which represents a serious health hazard if it were to find it's way back into the supply pipe. For this reason it must not be possible for any flexible shower head to be able to enter any adjacent Sink, WC or Bidet. If the flexible hose to be fitted could reach into any such vessel, the requirements to the system design are so onerous it is better not to fit a flexible. Rather, a fixed overhead showerhead should be considered. (See Figure 4).

It will also be seen that this risk could change should the hose be taken out of the restraining device or should a longer replacement hose be fitted at a later date. Installers and householders are advised to take account of these factors when fitting replacement hoses.

For pumped applications the pipe supplying the pump must not in addition supply an ascending spray bidet.

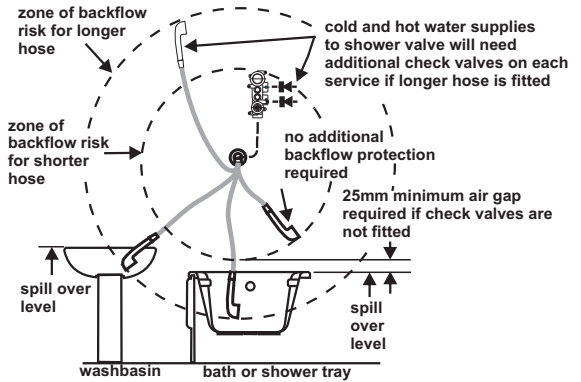

Figure 3 Backflow risk from a fluid category 3

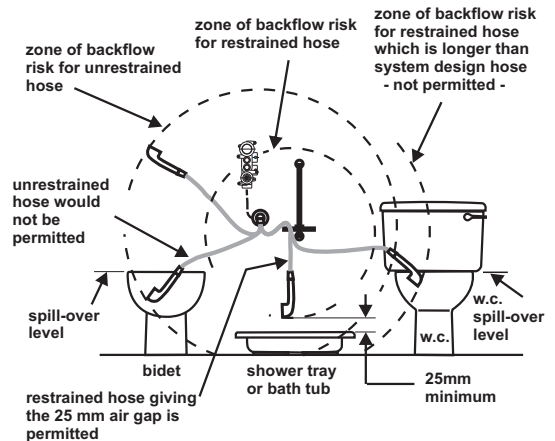

Figure 4 Backflow risk from a fluid category 5

4 INSTALLATION GUIDE

The thermostatic mixing valve must be installed in such a position that maintenance of the TMV and its valves and the commissioning and testing of the TMV can be undertaken.

1. The Thermostatic mixer can be installed with rear, rising or falling supply inlets. Decide on the most appropriate method of your installation, and rotate the elbows to suit.
2. Mark horizontally the positions of the holes for the backplate and pipe centres on the finished wall as shown

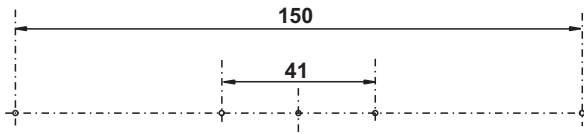

Figure 5

3. For exposed rising or falling supplies the pipe positions should be set 43mm from the centre of pipe to the finished wall at 150mm centres. Note if replacing an existing installation with pipework centres between 147mm and 155mm a universal retrofit accessory kit is available A5526AA
4. For solid walls drill the holes for the backplate with a 6mm drill and insert the wall plugs (supplied). For other types of wall structure alternative fixings may be required (not supplied)
5. For rear entry supplies only. Drill the holes for the supply pipes at 150mm centres.
Note!
Recess the inlet holes $\text{Ø}33\text{mm} \times 12\text{mm}$ deep to allow for the concealing plates.

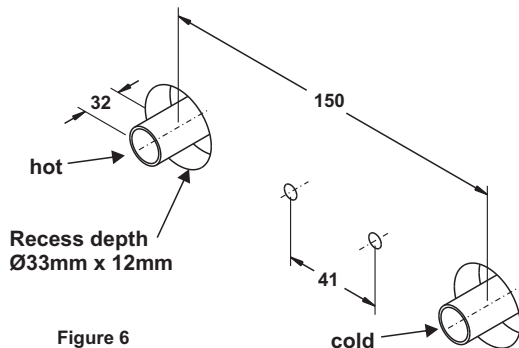

Figure 6

6. Fit the supply pipework: Hot on the Left / Cold on the right. The inlet pipework should extend 32mm (+/-1mm) from the finished wall surface.
7. Remove the backplate from the mixer by loosening the grub screw with a 2.5mm hexagonal key (supplied). Secure the mounting bracket to the wall with the screws and plugs provided.

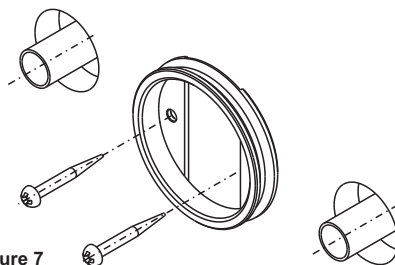

Figure 7

INSTALLATION GUIDE continued

8. For rear entry supplies only:
Fit the concealing plates over the inlet pipes.
Note! Apply silicone sealant to the back face of the plate.

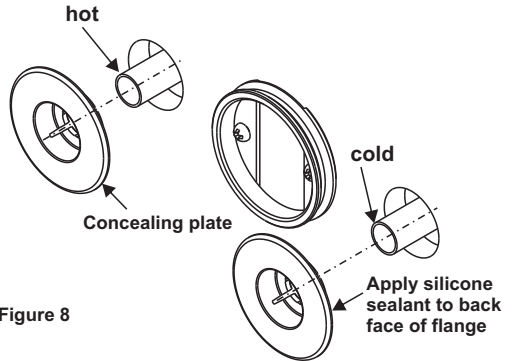

Figure 8

9. **Caution!** It is essential at this point that the supply pipework is thoroughly flushed through before connection to the mixer. Failure to do so may result in product malfunction.

10. Fit the compression nuts and olives onto the supply pipes. If 2nd outlet is required, this should be fitted now, see section 11

11. Align the mixer with the pipework and fit onto the backplate.

Important! Make sure that the hot and cold inlets on the mixer correspond with the hot and cold inlet supplies.

12. Tighten the grubscrew to secure the mixer to the backplate.

13. Tighten the compression nuts onto the mixer with a 24mm A/F spanner.

Caution! Take care not to damage the chrome surfaces.

14. Fix the shower fittings, refer to your shower fittings installation and user guide for instructions.

15. Turn on the hot and cold water supplies and check for leaks

16. Before using the shower refer to the Commissioning section

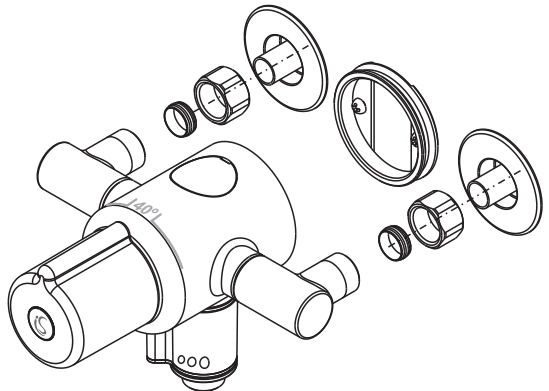

Figure 9

OPERATION

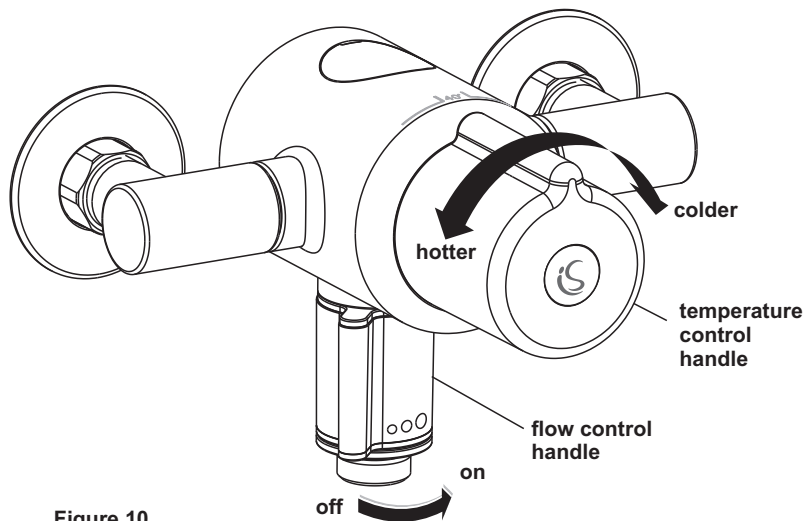

Figure 10

5 MAXIMUM TEMPERATURE STOP

The maximum mixed water temperature is factory set at 40°C. To change this temperature, remove the temperature control handle. Remove the temperature limit stop (black H-shaped plastic part) and reinsert it in the appropriate recess on the handle carrier. Four different settings are possible. 40°C, 43°C, 45°C & 50 °C (See fig 11). Refit temperature handle.

Details of the recommended code of practice for safe water temperatures can be found on the Thermostatic Mixing Valve manufacturers Association web site:
www.tmva.org.uk

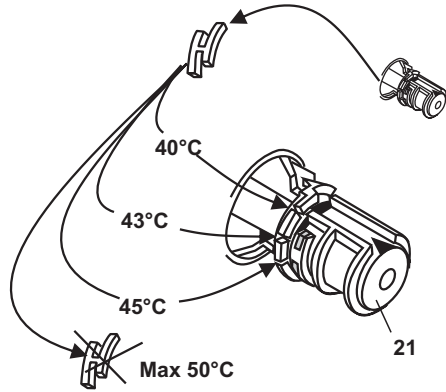

Figure 11

6 CALIBRATION

In the event of the thermostatic cartridge requiring re-calibration the following procedure should be undertaken.

1. Remove the Ideal Standard logo button and disconnect the handle.
2. Slide out the red "U" piece (b) exposing temperature control mechanism (d).
3. Turn on the shower, position a thermometer in the running water and when the temperature settles, rotate the temperature control mechanism until 40°C is achieved.
4. Reconnect the handle carrier (e) ensuring the arrow guide (c) is at 12 o'clock and refit the red "U" piece (b).
5. Reconnect the Handle and logo button.

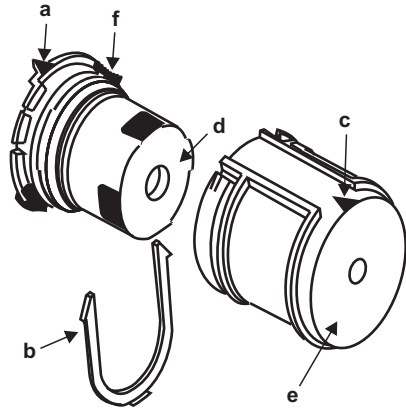

Figure 12

7 MAINTENANCE

The fitting of isolation valves and strainers should be as close as is practicable to the water supply inlets of the thermostatic mixing valve. The thermostatic cartridge seldom fails and the possibility of blocked filters should be investigated before contemplating replacing it. Small particles of debris may still find their way past the strainers and onto the filter screens on the thermostatic cartridge. These should be cleaned and re-fitted. See section on cartridge replacement.

8 ADVISED COMMISSIONING & PERIODIC CHECKS

The following procedures should be carried out after installation and every 12 months after to ensure that the valve is functioning correctly.

Check that:

1. The application of the thermostatic valve matches the approved designation.
2. The supply pressures are within the recommended range for the application.
3. The supply temperatures are within the permitted range for the application and comply with the guidance for prevention of Legionella.
4. The mixed temperature is as required for the application.

Record:

5. Each hot and cold supply. (Make a note of the measuring device used).
6. The mixed water temperature at the outlet device.

Isolate:

7. The cold supply to the mixing valve and record the mixed water temperature after about 5 seconds. The temperature should not exceed the value given in table (2) below.

Table 2 A guide to maximum temperature sets

| Application | Mixed water temperature | Advised maximum temperature rise during site testing |
|-------------|-------------------------|--|
| Shower | 41 °C | 43 °C |

Note: 46°C is the maximum advised mixed water temperature from a bath tap. The maximum temperature takes account of the allowable temperature tolerances inherent thermostatic mixing valves and temperature loss in metal baths. **It is not a safe bathing temperature for adults and children.**

The British Burns Association recommends 37°C-37.5°C as a comfortable bathing temperature for Children.

It should be noted in premises covered by the Care Standards Act 2000, the maximum mixed water temperature is 43°C

9 FREQUENCY OF REGULAR SERVICING

The purpose of servicing regularly is to monitor the performance of changes in system and valve set up. This may require the need to adjust either the supply system or the valve. The A5322AA should be checked and tested 12 months after commissioning.

Firstly measure the water temperature at the shower outlet.

Carry out the cold water supply isolation test by isolating the cold water supply to the TMV, wait for 5 seconds if water is still flowing check that the temperature is below 46C. If there is no significant change to the set outlet temperature (+/-2°C or less change from the original settings) and the fail-safe shut off is functioning, then the valve is working correctly and no further service work is required.

Notes:

A residual flow is permitted during the commissioning or the annual verification (cold water supply isolation test), then this is acceptable providing the water temperature is no more than 2°C above the designated outlet temperature.

Temperature readings should be taken at the normal flow rate after allowing for the system to stabilize.

The sensing part of the thermometer probe must be fully submerged in the water that is to be tested.

Any TMV that has been adjusted or serviced should be re-commissioned and retested in accordance with the instructions detailed above.

10 THERMOSTATIC CARTRIDGE REPLACEMENT

1. Remove the temperature control handle by first prizing out the index button with a small screwdriver and then removing the "pozi-drive" screw

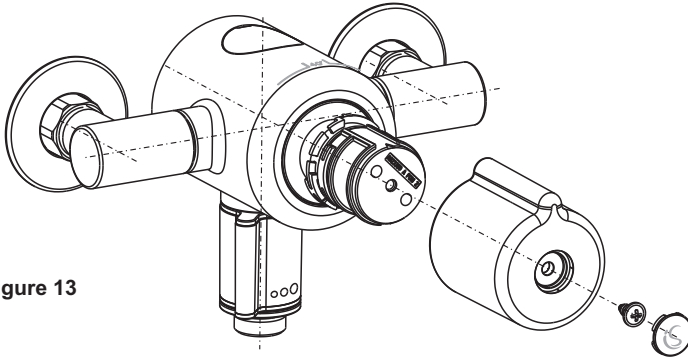

Figure 13

2. Remove the temperature handle carrier. To do this slide the black serrated lever in a clockwise direction with a screwdriver. Hold it there and pull off the carrier.

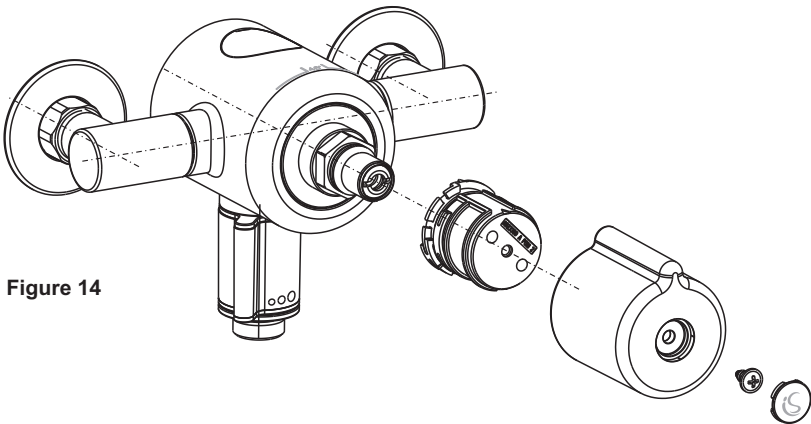

Figure 14

3. The thermostatic cartridge can then be unscrewed with a 24mm A/F Spanner. Refit the cleaned original or a new thermostatic cartridge and replace the carrier and handle

11 MOVING THE OUTLET MECHANISM TO THE TOP OF THE FITTING (For fixed head exposed riser)

Important! Mixer must not be connected to the water supply when moving the outlet mechanism.

1. Using a small screwdriver carefully remove the plug cap from the sealing plug at the top of the mixer.
2. Remove the sealing plug securing grub screw from the rear of the mixer with a 2.5mm hexagonal key (supplied).
3. Remove the sealing plug, using pliers to grip the central peg.

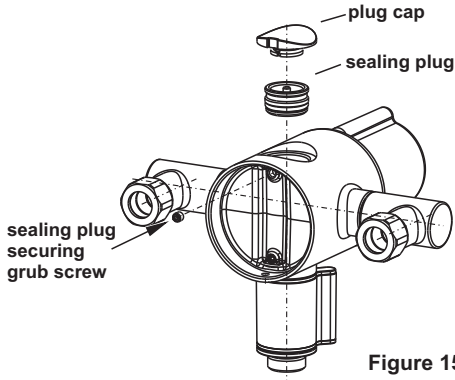

Figure 15

4. Remove the outlet securing grub screw from the rear of the mixer with a 2.5mm hexagonal key (supplied).
5. Assemble the outlet at the top of the fitting, taking care to align the outlet flat with the securing grub screw as shown.

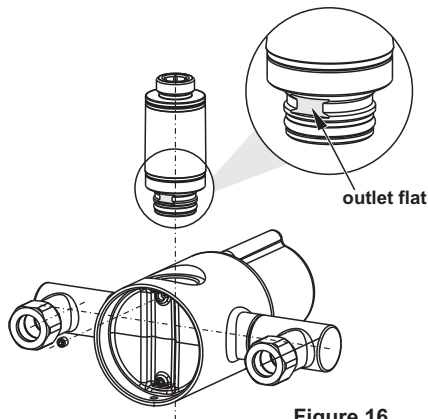

Figure 16

6. Fit and tighten the securing grub screw against the outlet flat with the 2.5mm hexagonal key (supplied).
7. Assemble the sealing plug at the bottom of the fitting.
8. Fit and tighten the securing grub screw with the 2.5mm hexagonal key (supplied).
9. Assemble the plug cap into the sealing plug, positioning the removal slot towards the rear of the fitting.

12 INSTALLING THE OPTIONAL SECOND OUTLET A5525AA (NOT SUPPLIED)

The second outlet kit allows your thermostatic mixer to be connected to a fixed overhead shower

Kit contains

2.5mm A/F Hexagonal Key,
ILV Assembly Clockwise Close,
Instruction leaflet

Important!

Mixer must not be connected to the water supply when adding the second outlet.

If mixer has been fitted to the wall, it must be removed to permit access to rear.

1. Using a small screwdriver carefully remove the plug cap from the sealing plug at the top of the mixer.
2. Remove the Sealing plug securing grub screw from the rear of the mixer with a 2.5mm hexagonal key (supplied).
3. Remove the sealing plug, using pliers to grip the central peg.
4. Assemble the second outlet, taking care to align the outlet flat with the securing grub screw shown.

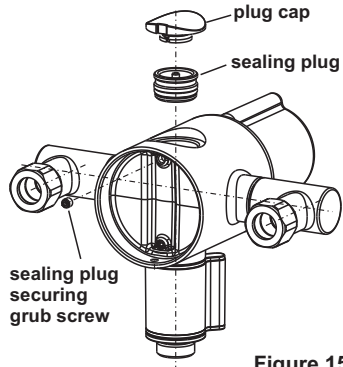

Figure 15

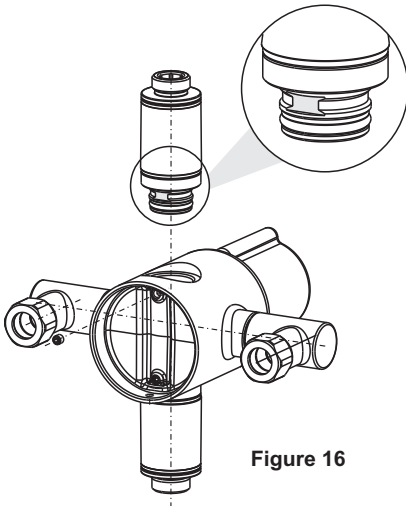

Figure 16

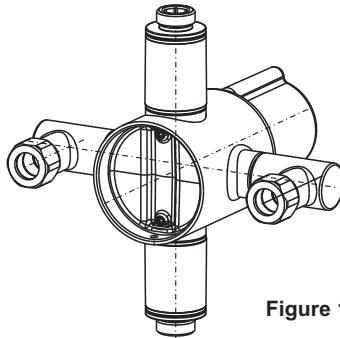

Figure 17

5. Fit and tighten the securing grub screw against the outlet flat with the 2.5mm hexagonal key (supplied).

13 RETRO FIT INSTALLATION WITH ADJUSTABLE INLETS PACK - A5526AA (NOT SUPPLIED)

The adjustable inlets each have adjustment of 4mm, allowing your thermostatic mixer to be connected to pipe centres ranging from 147mm to 155mm

The adjustable external backplate allows for 5mm adjustment from the finished wall surface

Kit contains:

- Adjustable Inlet Elbows x 2
- External Backplate
- Adjustable Inlet Connectors x 2
- Check valves x 2
- M5x5 Grub Screws x 2
- 2.5mm A/F Hexagonal Key
- Instruction leaflet
- Wall plugs & fixings x2

INSTALLATION

1. Unscrew the original elbows from the mixer body and discard
2. Remove and discard the internal backplate from the mixer by removing the grub screw with a 2.5mm hexagonal key (supplied).

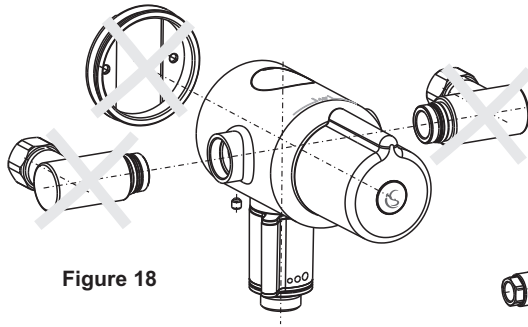

Figure 18

3. Fit the new adjustable inlet connectors into the mixer and tighten them using a 14mm A/F Spanner

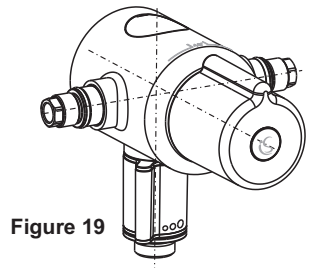

Figure 19

4. Screw the adjustable inlet elbows onto the connectors and position them at the existing pipework centre distance. Note! Must be between 147mm and 155mm
5. Draw a centre line on the wall surface between the existing inlet pipework.
6. Using the new adjustable external backplate as a template, mark the position of the backplate fixing holes.
7. For solid walls drill the holes for the backplate with a 6mm drill and insert the wall plugs (supplied). For other types of wall structure alternative fixings may be required (not supplied).
8. Secure the new backplate to the wall using the screws (supplied).
9. Align the mixer with the pipework and fit onto the backplate. Note! Make sure that the pipes are pushed fully into the inlet connectors.

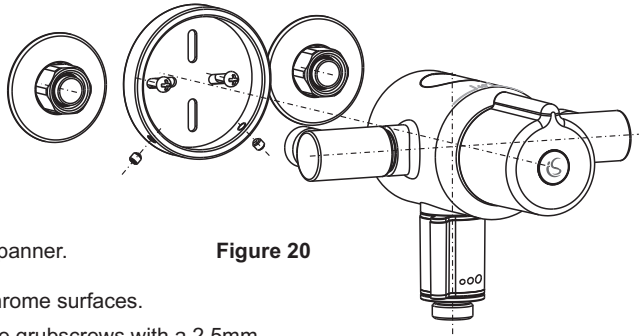

Figure 20

10. Tighten the compression nuts onto the mixer with a suitable spanner.

Caution!

Take care not to damage the chrome surfaces.

11. Tighten the adjustable backplate grub screws with a 2.5mm hexagonal key (supplied) to secure the mixer to the backplate.
12. Refer to the Thermostatic mixer and shower fittings installation and user guides for further installation and commissioning procedures.

14

SPARE PARTS

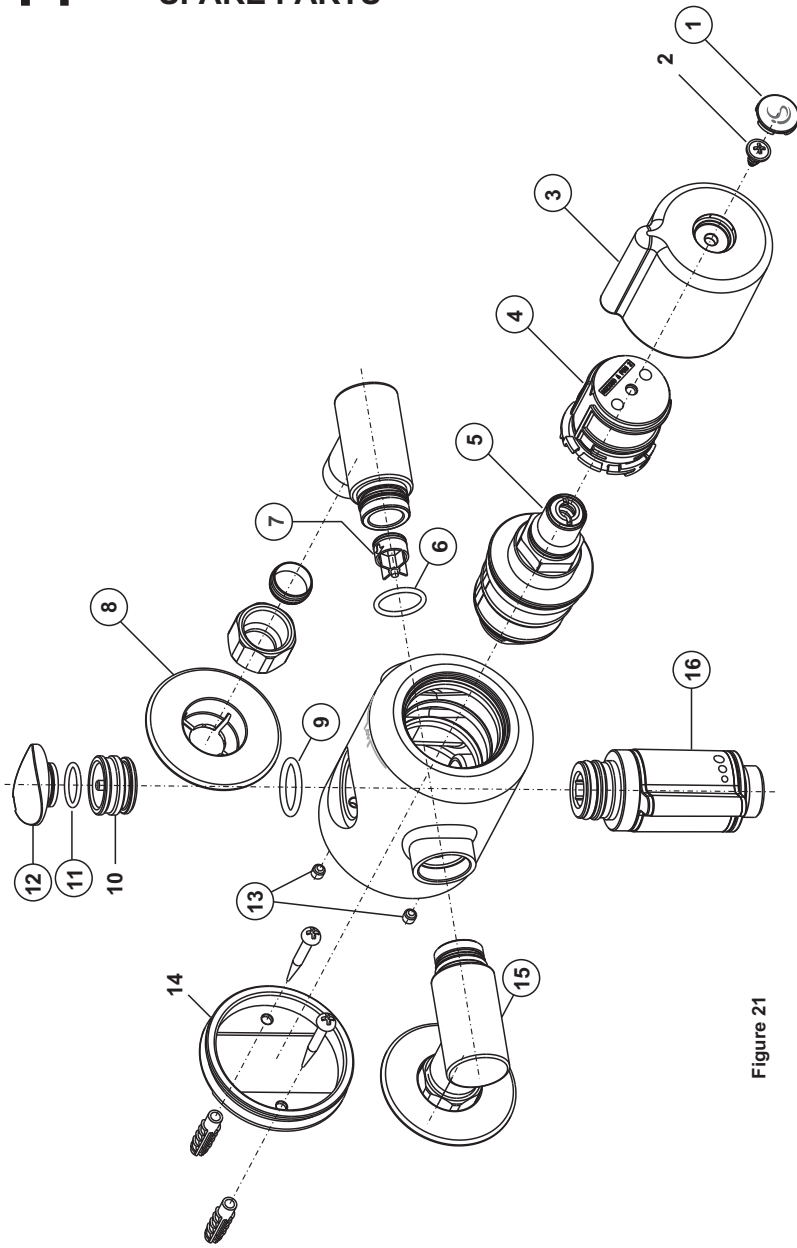

Figure 21

| Ref. | Description | Part No. |
|-------------|-----------------------------|-----------------|
| 1 | Cover Button | A961951NU |
| 2 | Screw - handle fixation | - |
| 3 | Temperature control handle | A962577AA |
| 4 | Temperature handle carrier | A963427NU |
| 5 | Thermostatic cartridge | A960587NU |
| 6 | O-ring | A961810NU |
| 7 | Check valve | A860415NU |
| 8 | Escutcheon | A962587AA |
| 9 | O-ring | A963143NU |
| 10 | Sealing plug | - |
| 11 | O-ring | A962605NU |
| 12 | Plug cap | A962612AA |
| 13 | Grub screws | A962625NU |
| 14 | Back mounting plate | - |
| 15 | Inlet elbow assembly | A962613AA |
| 16 | Flow control valve assembly | A962624AA |
| 17 | Flow restrictor 4 l/min | A962570NU |
| 18 | Flow restrictor 8 l/min | A962571NU |



CUSTOMER CARE HELP LINE

0870 129 6085

CUSTOMER CARE FAX

01482 499611

E-MAIL

UKcustcare@idealstandard.com

Ideal Standard pursues a policy of continuing improvement in design and performance of its products.

The right is therefore reserved to vary specification without notice.

Ideal Standard is a division of Ideal Standard (UK) Ltd

Ideal Standard,
The Bathroom Works, National Avenue
Kingston-upon-Hull, HU5 4HS, England

T122/a - 10/10

A866228

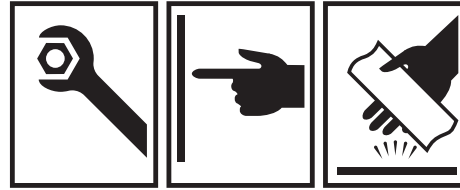
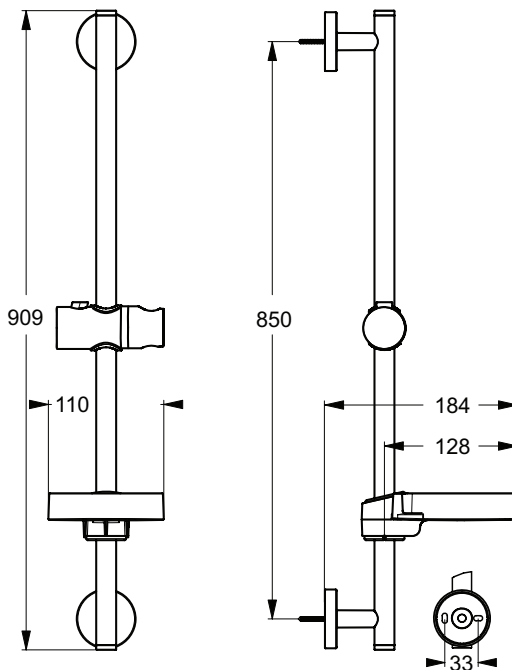
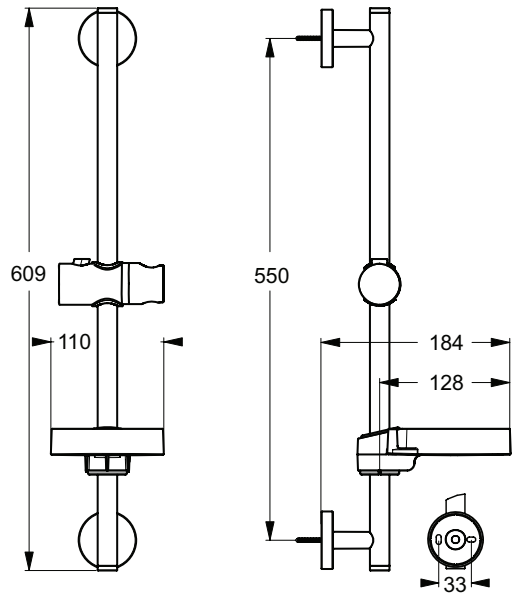

Ideal STANDARD

BG

Ideal Standard International
Ideal Standard-Vidima AD
53, Marin Popov str.
5400 Sevlievo, Bulgaria
Tel.: +359 675 30 368
Fax: +359 675 30 814

EU

Ideal Standard International BVBA
Corporate Village – Gent Building
Da Vincilaan 2
1935 Zaventem
Belgium
<http://www.idealstandardinternational.com>

D

Ideal Standard GmbH
Deutschland
Euskirchener Str. 80
53121 Bonn
Tel.: +49-(0)228-521-0
Fax: +49-(0)228-521-241

UK

Ideal Standard (UK) Ltd
The Bathroom Works
National Avenue
Kingston upon Hull
HU5 4HS
England
Tel.: +44 01482 346461
Fax: +44 01482 445886

F

Ideal Standard France
165, Av. du Bois de la Pie Bâtiment H
Parc des Reflets
95920 Roissy CDG
Tel.: +33 1 49 38 28 00
Fax: +33 1 49 38 28 28

I

Ideal Standard Italia S.r.l.
Via Domodossola, 19-
20145 Milano
Tel.: +39 800 652290
(toll-free number)

NL

Ideal Standard Nederland BV
L.J.Costerstraat 30
Postbus 7
5900 AA Venlo
Tel.: +31 (0)77 355 08 08
Fax: +31 (0)77 354 21 86

E

Ideal Standard,
S.L.Spain
Sant Marti, s/n
08107 Martorelles (Barcelona)
Tel.: +34 93 561 80 00
Fax: +34 93 570 63 12

PT

Ideal Standard Portugal
Nogueira - Ap4
4711-909 Braga
Portugal
Tel.: +351 253683141
Fax: +351 253683186

GR

Ideal Standard Greece
S.A.265, Mesogeion Ave.
N.Psychiko - 15451
Athens - Greece
Tel.: +30 210 6790800
Fax: +30 210 6790890

RU

Ideal Standard RUS
31-G, Shabolovka st
115998 Moscow Russia
Tel. +7 495 669 29 11
Fax: +7 495 669 23 12

UA

Ideal Standard International
Representative Office in Ukraine
89 Saksaganskogo str., KV.1
01032 Kiev, Ukraine
Tel./Fax: +380 44 537 32 72

BeLux

Ideal Standard Produktions-GmbH
Ikaroslaan 18
1930 ZAVENTEM / Belgium
Tel.: +32 (0)2 325 66 00
Fax: +32 (0)2 325 66 01

TR

Ideal Standard Türkiye
Şerif Ali Çiftliği Yan Yol Bölgesi,
Bayraktar Bulvarı, Miraç Sokak,
No:55 Ümraniye/İstanbul
Tel: 0216 3148787
Fax: 0216 4998357

CZ

Ideal Standard a.s.
Česká republika
Zemská 623
415 74 Teplice
Tel.: +420 417 59 21 11
Fax: +420 417 56 07 72

