

Slimline magnetic lock is suitable for Timber or Aluminium Internal doors to provide controlled access via an Access Control System. It should not be used as the only lock securing the door, a mortice deadlock or similar should also be fitted. It is essential that the Header Frame and Top Rail of the door are strong enough to accommodate the magnet and Armature Plate, if in doubt consult door and frame supplier for advice.

**NOTE: THIS LOCK IS SUITABLE FOR SOLID DOORS 35 - 55mm THICK OR HOLLOW DOORS 35 - 46mm THICK.**

**Important points to consider during installation:**

1. Check that the door is properly aligned with the door frame when in the closed position. If the gap around the door and frame is not equal the magnet should not be fitted until the door is correctly aligned.
2. Always handle the equipment with care as damage to the mating surfaces of the magnet or armature plate may reduce locking efficiency.
3. Ensure the correct screws and fittings from the fixing pack are used as incorrect screws or fittings will affect the operation of the magnetic lock and armature plate.
4. It is essential that the magnetic lock and armature plate are correctly aligned and installed correctly.
5. When using the template the door must be in the closed and latched position.
6. Thread lock must be applied to all threads on the magnetic lock and fixing brackets and the armature plate bolt.

EXAMPLES OF THE 3 DIFFERENT FRAME TYPES		
FRAME DETAIL - OUTWARD OPEN 1	FRAME DETAIL - OUTWARD OPEN 2	FRAME DETAIL - INWARD OPEN
DEEP FRAME HEADER    FIG 1	SHALLOW FRAME HEADER    FIG 2	Z&L BRACKET APPLICATION    FIG 3
<b>A = FRAME HEADER DEPTH    B = DOOR TOP RAIL HEIGHT    C = DOOR FRAME HEIGHT</b>		

There are two different fixing options for Outward opening doors and one for Inward opening doors.

The fixing option you use will depend on the height and depth of the Door frame header.

1. Fig. 1 shows an outward opening door with a deep frame header. The Standard Flat Mounting plate which comes with the magnet can be used if measurement 'A' is at least 50mm (2") and 'B' is at least 50mm (2").
2. Fig. 2 shows an outward opening door with a shallow frame header. The optional Transom 'L' bracket (AC-EMBR008) must be used if measurement 'A' is less than 35mm (1.38") and 'B' is at least 50mm (2").
3. Fig. 3 shows an inward opening door for which the 'Z&L' bracket set must be used. The optional 'Z&L' bracket set (AC-EMBR089F) must be used if measurement 'A' is up to 25mm (1") and 'B' is at least 65mm (2.56"), 'C' must be at least 40mm (1.57").

**If any of the above measurement requirements do not match you may need to use a different magnetic lock.**

FIXING PACK CONTENTS			QTY
A	G	O	A M8 Counter sunk Allen bolt 50mm (2") long    1
B	H		B Dome nut 41 x 12mm (1.6x0.5") Chrome    1
C	J		C Aluminium spacer 43 x 16mm (1.7x0.63") (For hollow doors)    1
D	L		D 3.9 x 25mm (No 8x1") Csk wood screw    9
E	M		E 5 x 15mm (No 10x0.6") Csk wood screw (for slotted holes)    2
F	N		F Steel washer 22mm (0.87") diameter (for Armature plate)    2
			G Rubber washer 15mm (0.6") diameter (for Armature plate)*    2
			H Guide pin 16 x 5mm (0.63x0.2") (split dowel)    2
			J M3 x 18mm (0.71") Csk screw (thread relieved)    2
			L Allen key wrench 3 x 63mm (0.1x2.48")    1
			M M8 Nylock nut (for use with Allen bolt Q on 'Z' bracket)    1
			N M4 Allen bolt 24mm (0.95") long Incl head**    2
			O Metal spacer 13 x 7mm (0.5x0.27")**    2
			* + 1 Spare
			** Items already fitted into the Magnet

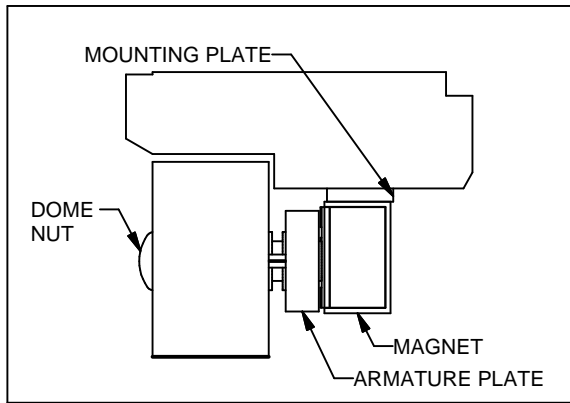

**ASSEMBLED ELECTRO MAGNET**

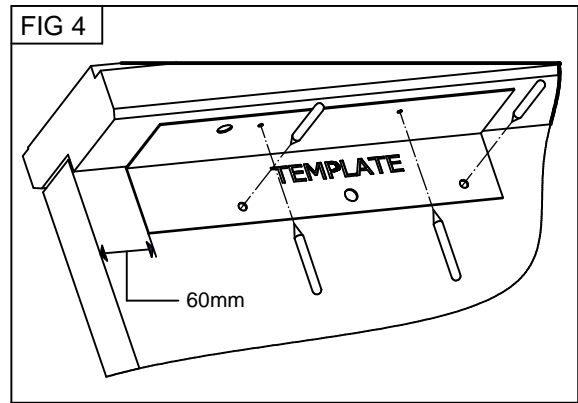

1. Check that the magnet will fit to the Door & Head Frame (fig 1).
2. With the door closed and latched fix the template to the door and frame. Place the edge of the template 60mm (2.4") from the side frame (fig 4).
3. Mark the centre of each hole shown on the template and drill holes to size and depth stated on Template.
4. **From the outside** of the door enlarge the 9mm hole to 12mm to a depth of 36mm (On Hollow doors enlarge the hole to 16mm through the outer door skin only to accommodate the Aluminium spacer (C).

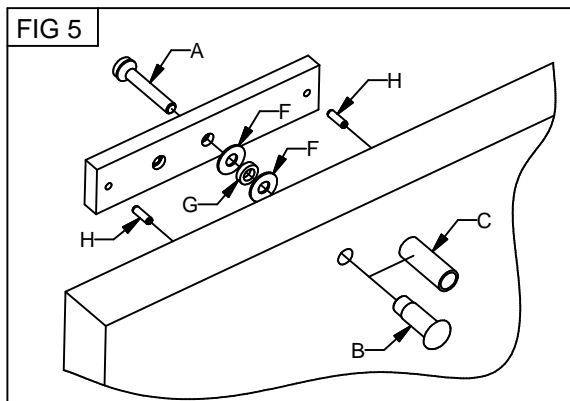

5. Push the Dome nut (B) into the 12mm hole in the door (for a hollow door push the the Aluminium spacer (C) into the 16mm hole then cut down flush with door face. Push Dome nut (B) into Spacer (C).
6. Gently tap the 2 guide pins (H) into the holes on the back of the Armature plate. Push the M8 50mm Allen bolt (A) through the countersunk hole in the Armature plate. Slide a Steel washer (F) over the M8 Allen bolt at the back of the Armature plate followed by a Rubber washer (G) and a Steel washer (F). (fig 5).
7. Fix the Armature plate to the door using a 5mm Allen key and tighten until the Armature plate sits 3-5mm away from the face of the door. **Do not apply thread lock at this stage.**

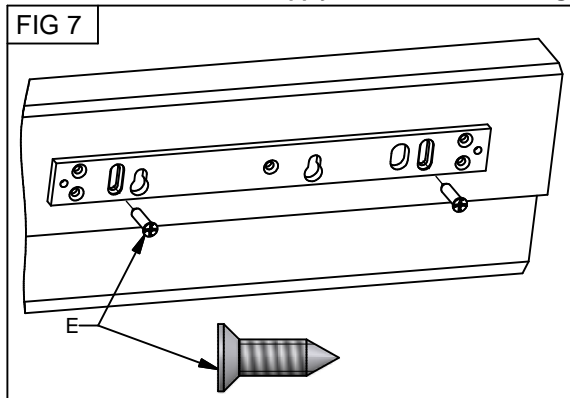

9. Place the Mounting plate on to the frame making sure the 10mm cable hole is visible through the oval hole of the plate. Fix using two No 10 15mm Csk screws (E) through the slotted holes into pilot holes drilled previously (fig 7).

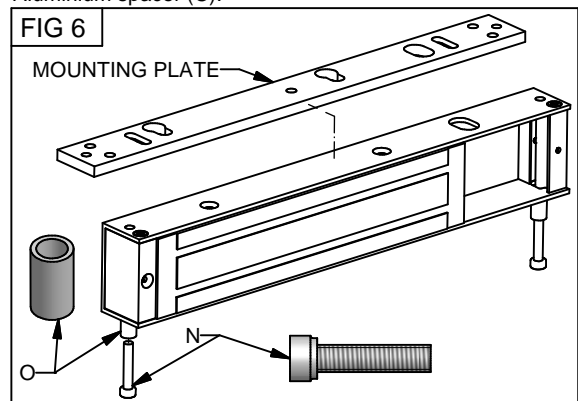

8. Using the Allen key wrench (L) remove the two M4 Allen bolts (N) and metal spacer (O) through the holes at the base of the magnetic lock to release the flat mounting plate (fig 6).

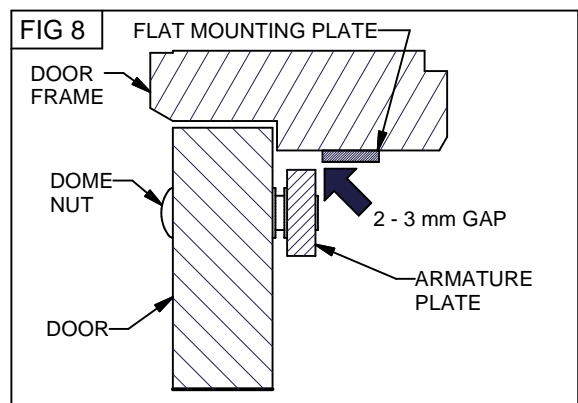

10. With the door closed and latched adjust the Mounting plate towards the Armature plate until the edges are 2-3mm apart and parallel along the full length of the armature plate (fig 8).

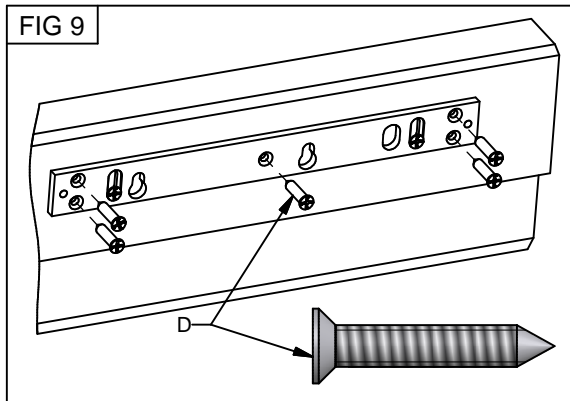

11. Mark the centres of the 5 countersunk holes through the Mounting plate.
12. Drill five 3.5mm dia. holes to a depth of 20mm.
13. Fix the Mounting plate with the 5 No. 8 32mm Csk screws (D). (fig 9).

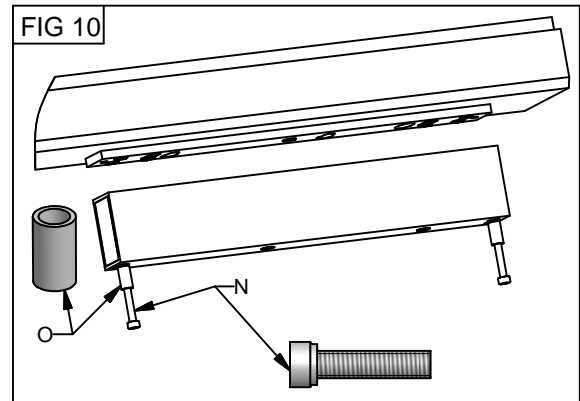

14. Hold the Magnet with the front facing the armature plate. Lift the magnet up onto the Mounting plate. (fig 10).
15. Fix the magnet to the mounting plate using two M4 Allen bolts (N) and Metal Spacer (O) fixed through the holes in the bottom of the magnet and tighten with the Allen key wrench (L).

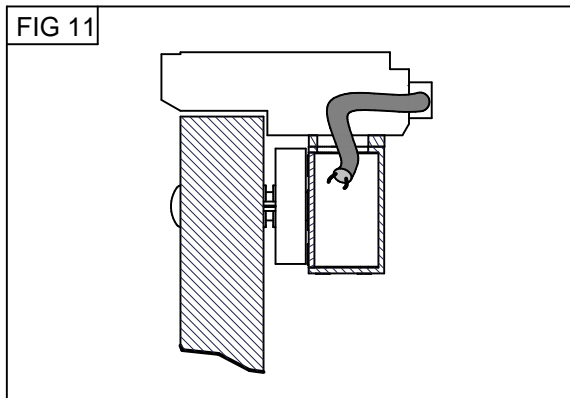

16. Pass lock cable through the 10mm hole in the door frame (fig 11) and connect to Magnet PCB as per wiring instructions on pages 7&8.
17. Apply voltage to the Magnet. Close the door and check Armature plate is correctly aligned with the magnet. Apply firm pressure against the door to check magnet is holding properly. Remove voltage and open the door.

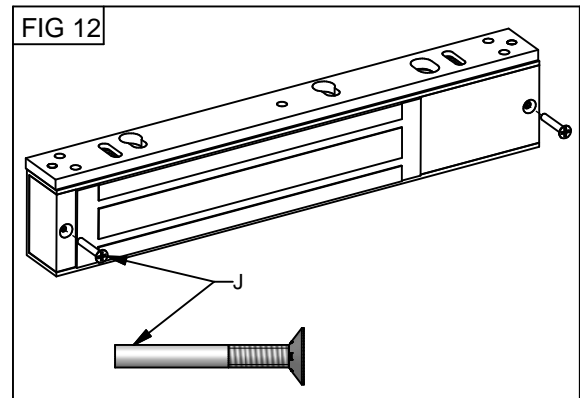

18. Remove M8 Allen bolt (A) from the Armature plate and apply Thread lock. Re-fit as per steps 6&7.
19. Remove one at a time the M4 Allen bolt (N) from the bottom of the magnet and apply Thread lock. Re-fit as per step 15.
20. Using the two M3 18mm Csk screw (J) fix the PCB cover plate in position on the magnet and into the counter sunk hole at the opposite end (fig 12). These screws will prevent the M6 Allen bolt from unscrewing see fig 12A.

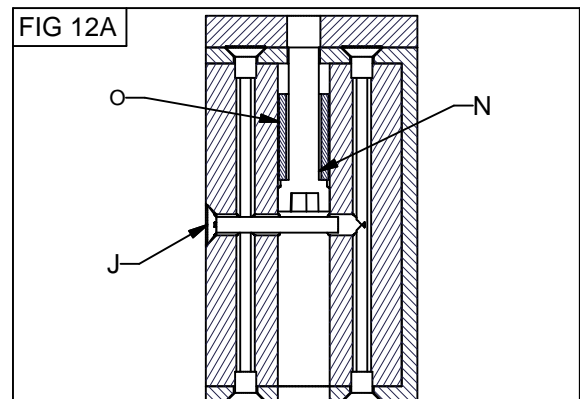

**SAFETY FEATURE WHICH PREVENTS ALLEN BOLTS FROM UNSCREWING**

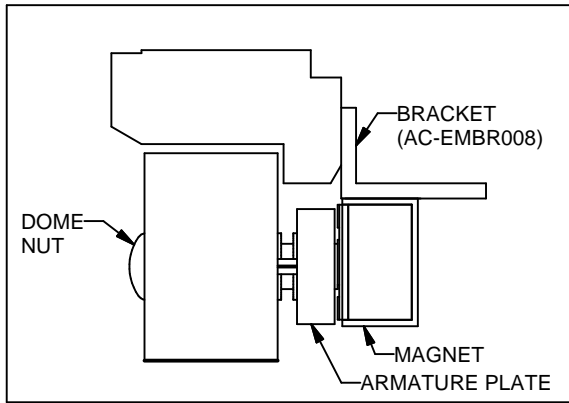

ASSEMBLED ELECTRO MAGNET

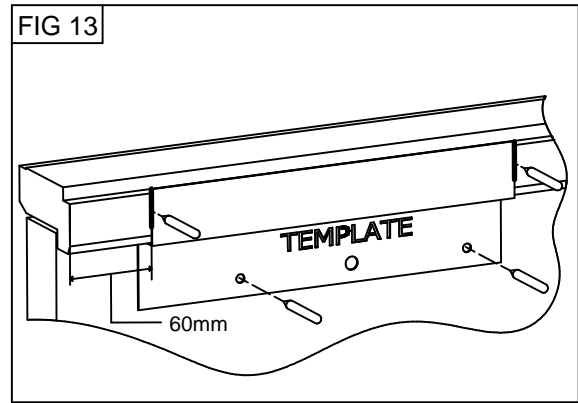

1. Check that the Magnet and Bracket will fit to the Door and Head Frame. (fig 2).
2. With the door closed and latched, tape the template to the door and frame. Place the edge of the template 60mm from the side frame. (fig 13).
3. Mark vertical lines for the 'L' bracket at the edge of the template, mark centre of each hole shown on the template. Drill all holes to the size and depth shown on template.
4. From the outside of the door enlarge the 9mm hole to 12mm to a depth of 36mm (on a hollow metal door drill a 16mm hole through the outer door skin only to accommodate the Aluminium spacer (C).

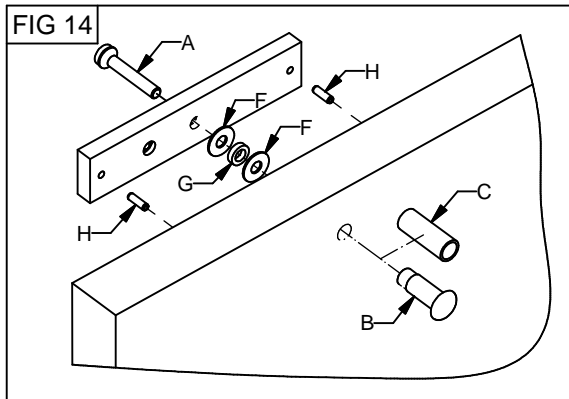

5. Push the Dome nut (B) into the 12mm hole in the door (for a hollow door push the the Aluminium spacer (C) into the 16mm hole then cut down flush with door face. Push Dome nut (B) into Spacer (C).
6. Gently tap the 2 guide pins (H) into the holes on the back of the Armature plate. Push the M8 50mm Allen bolt (A) through the counter sunk hole in the Armature plate followed by one Rubber washer (G) sandwiched between 2 Steel washers (F) behind the Armature plate. (fig 14).
7. Fix the Armature plate to the door using a 5mm Allen key and tighten until the Armature plate sits 3-5mm away from the face of the door. **Do not apply thread lock at this stage.**

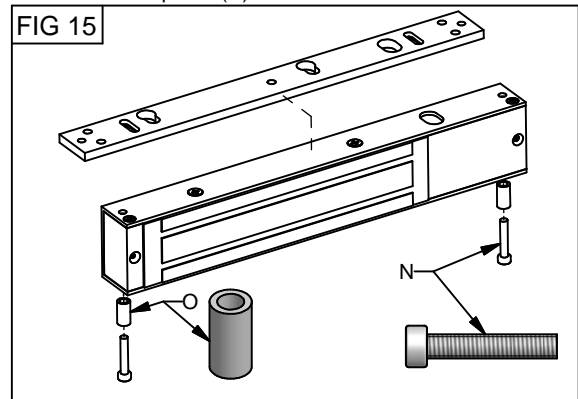

8. Using the Allen key wrench (L) remove the two M4 Allen bolt (N) and Metal spacer (O) through the bottom of the magnetic lock. Lift up the Mounting plate and remove it from the magnet. (fig 15).

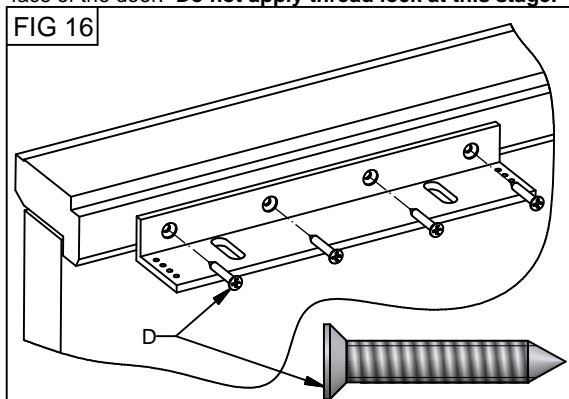

9. Use the Transom 'L' bracket (AC-EMBR008) as a template. Place the short side between the vertical lines on the frame (make sure it is flat against the frame) the bottom of the bracket should be 5mm below the underside of the frame header (fig 16).
10. Mark the centres of the four Counter sunk holes. Drill 3.5mm dia holes to a depth of 20mm. Fix the 'L' bracket using four No 8. 25mm Csk screws (fig 16).

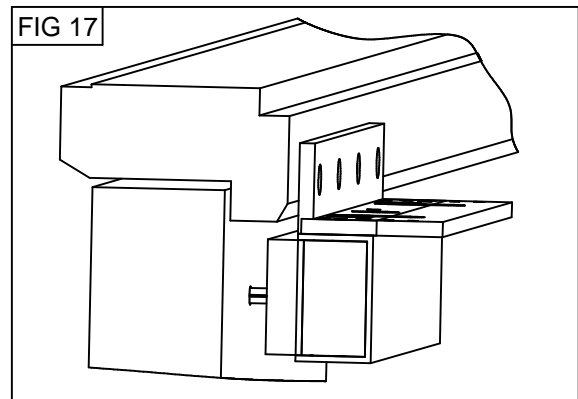

11. With the door closed and latched place the face of the magnet so that it touches the Armature plate and check that the hole in the top of the magnet lines up with one of the tapped holes on the bracket. If the holes do not line up loosen the M8 Allen bolt (A) making sure the gap behind the armature plate is no more than 7mm. (fig 17).

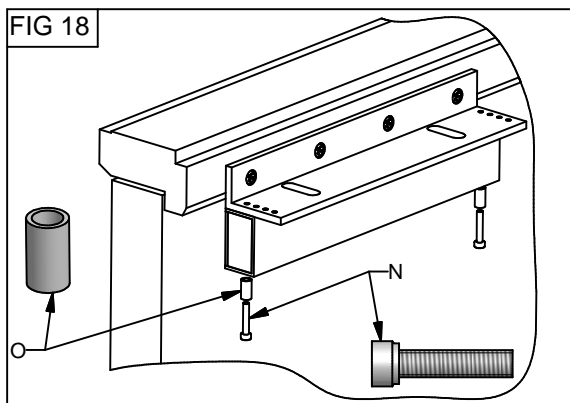

12. Fix the magnet to the bracket using two M4 Allen bolts (N) and Metal spacer (O) fixed through the holes in the bottom of the magnet and tighten with the Allen key wrench (L). (fig 18).

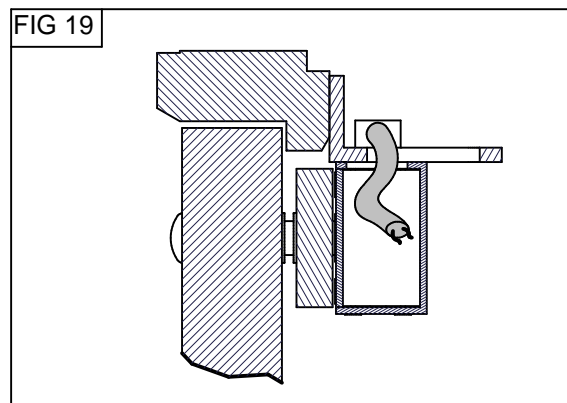

13. Pass lock cable through the cable entry hole (fig 19) and connect to Magnet PCB as per the wiring instructions on pages 7&8.

14. Apply voltage to the Magnet. Close the door and check Armature plate is correctly aligned with the magnet. Apply firm pressure against the door to check magnet is holding properly. Remove voltage and open the door.

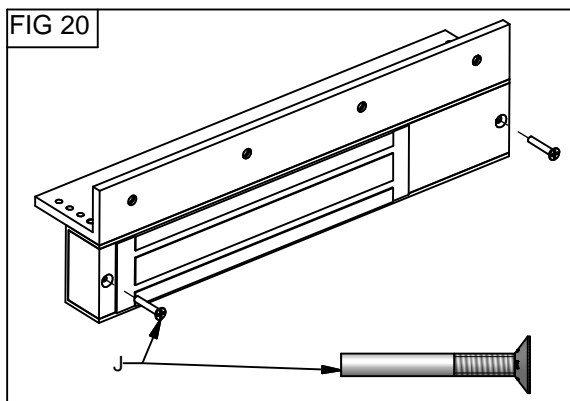

15. Remove M8 Allen bolt (A) from Armature plate and apply Thread lock. Re-fit as per step 6&7.

16. Remove one at a time the M4 Allen bolts (N) from the bottom of the magnet and apply Thread lock. Re-fit as per step 12

17. Using the two M3 18mm Csk screw (J) fix the PCB Cover plate in position on the magnet and into the counter sunk hole at the opposite end (fig 20). These screws will prevent the M4 Allen bolts from unscrewing (see fig 20A).

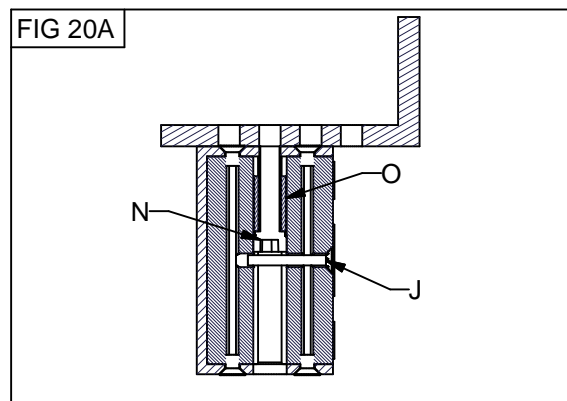

**SAFETY FEATURE WHICH PREVENTS ALLEN BOLTS FROM UNSCREWING**

The Slimline Double magnetic locks are used for a pair of double doors. They are fixed in exactly the same way as the Single version using 2 fixing packs.

**Installation to Deep Header frame using Flat Mounting Plate**

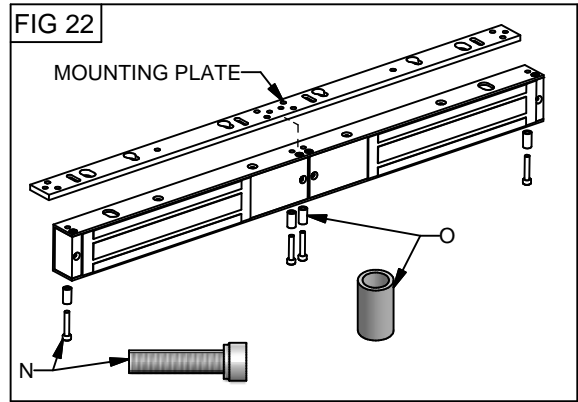
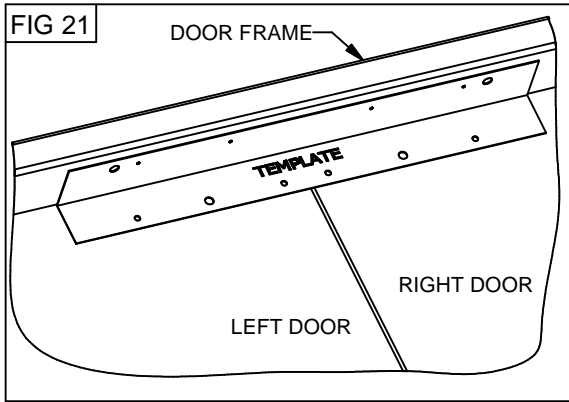

1. With both doors closed and latched fix the template across the centre of both doors and continue as steps 3&4 on page 2 (see Fig. 21).
2. Fit the 2 Armature plates to each door as per steps 5-7 (Fig.5) on page 2.
3. Remove the four M4 allen bolts (N) and Metal spacers (O) as per step 8 page 2 (see Fig.22).
4. Fix the Mounting plate using 4 No.10 15mm Csk screws (E) as per step 9 page 2. Ensure Mounting plate is adjusted correctly as per step 10 (Fig.8) page 2.
5. Fix the mounting plate using 10 No.8 25mm Csk screws (D) as per steps 11-13 (Fig.9) page 3.
6. Fix the Magnet to the mounting plate using four M4 Allen bolts (N) & Metal Spacers (O) as per steps 14&15 page 3.
7. Fit 2 separate cables for each magnet PCB as per steps 16&17 (Fig.11) page 3.
8. Apply Thread lock to Allen Bolts as per steps 18&19 page 3.
9. Fit four M3 18mm Csk screws (J) as per step 20 (Fig.12) page 3.

**Installation to Shallow Header frame using 2 Transom 'L' Brackets**

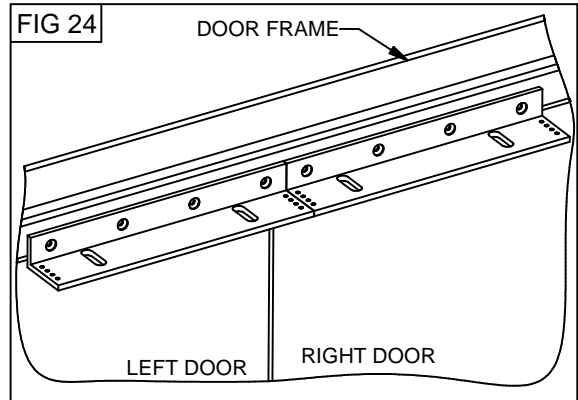
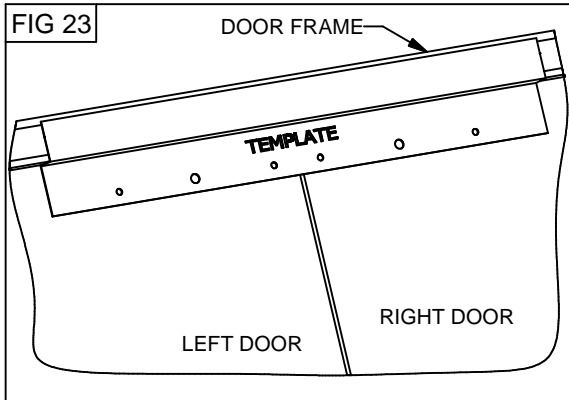

1. With both doors closed and latched fix the template across the centre of both doors and continue as steps 3&4 on page 4 (see Fig. 23).
2. Fit the 2 Armature plates to each door as per steps 5-7 (Fig.5) on page 4.
3. Remove the four M4 allen bolts (N) and Metal spacers (O) as per step 8 page 4 (see Fig.22).
4. Place the two 'L' brackets together and continue as per steps 9&10 page 4 (see Fig.24).
5. Close both doors and line up Magnet with brackets as per step 11 (Fig.17) page 4.
6. Fix the Magnet to the 2 'L' brackets using four M4 Allen bolts (N) & Metal Spacers (O) as per step 12 (Fig.18) page 5.
7. Fit 2 separate cables for each magnet PCB as per steps 13&14 (Fig.19) page 5.
8. Apply Thread lock to Allen Bolts as per steps 15&16 page 5.
9. Fit four M3 18mm Csk screws (J) as per step 17 (Fig.20) page 5.

The Slimline magnet is designed to be operated by 12 or 24 volt DC systems. The Printed Circuit Board (PCB) in the magnet is factory set for 12V operation but can easily be changed for 24V operation (see wiring detail). The PCB also has built-in protection against Back EMF surges which means a separate Diode or MOV is not needed. Because the magnet is Fail Unlock (Fail Safe) it needs a constant DC supply to hold the Armature plate in position, it is therefore recommended that a Rechargeable Battery is fitted in the Power supply.

Important Points to consider before Installation:-

1. The Magnet must be connected to a Regulated DC Power supply (Ideally with Battery Backup facility).
2. Input voltage at the magnet PCB must be 12 or 24V  $\pm$  10%
3. The PCB already has built-in protection against Back EMF surges.
4. The Maximum current draw for 12V is 500mA and for 24V 250mA (Double version will draw twice as much).
5. DO NOT reverse polarity as this will result in damage to the PCB and Coil.
6. There are two versions of the PCB - Unmonitored (Models 10001 and 10003) and Monitored (Models 10002 and 10004).
7. Ensure all cabling and wiring connections conform to current Electrical Legislation.

Wiring detail for Standard Magnet UnMonitored - Model:10001 / 10003

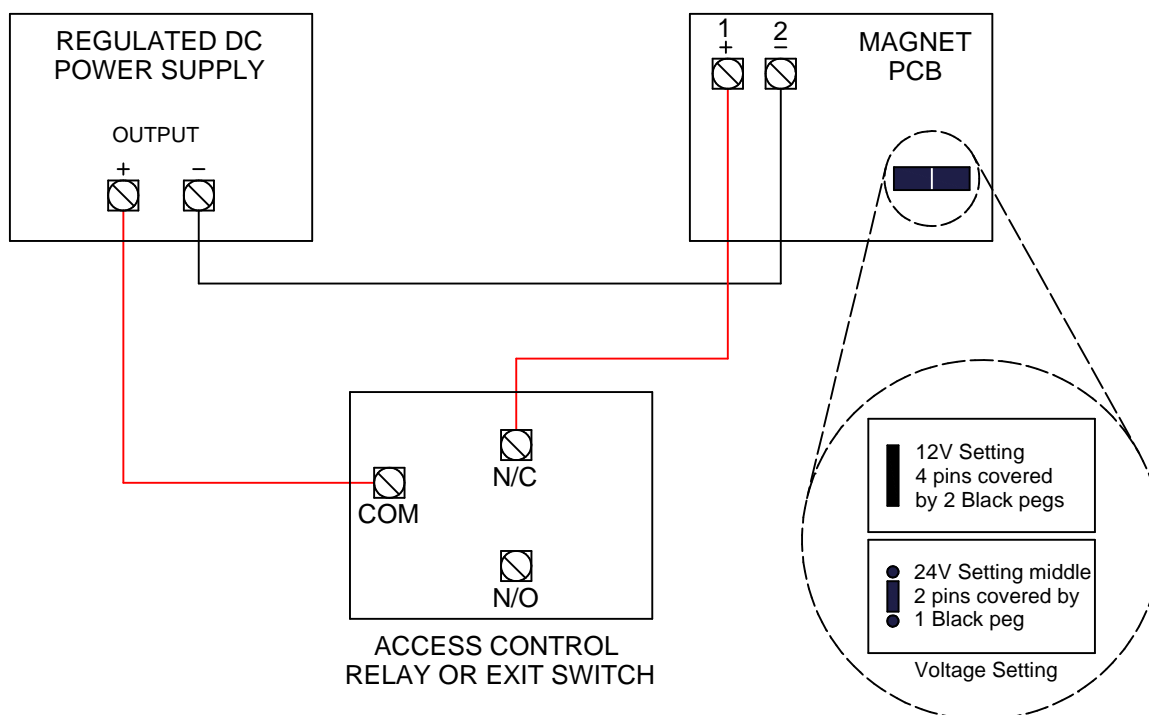

1. Check magnet PCB is set for correct voltage (Factory setting is 12V).
2. Connect Negative Output (-) from Power Supply to terminal 2 (-) on Magnet PCB.
3. Connect Positive Output (+) from Power Supply to Common of Relay or Exit switch.
4. Connect Normally Closed (N/C) on Relay or Exit switch to terminal 1 (+) on Magnet PCB.
5. With the door open switch Power supply On and check that the Magnet will hold a Screwdriver.
6. Operate the Access Control Relay or Exit switch whilst holding the screwdriver to check magnet is working.
7. If the Screwdriver is released close the door and check the Holding force by pulling / pushing the door.
8. Re-fit the PCB cover plate with M3 18mm Csk Screw (J).

Wiring detail for Standard Magnet Monitored - Model 10002 / 10004

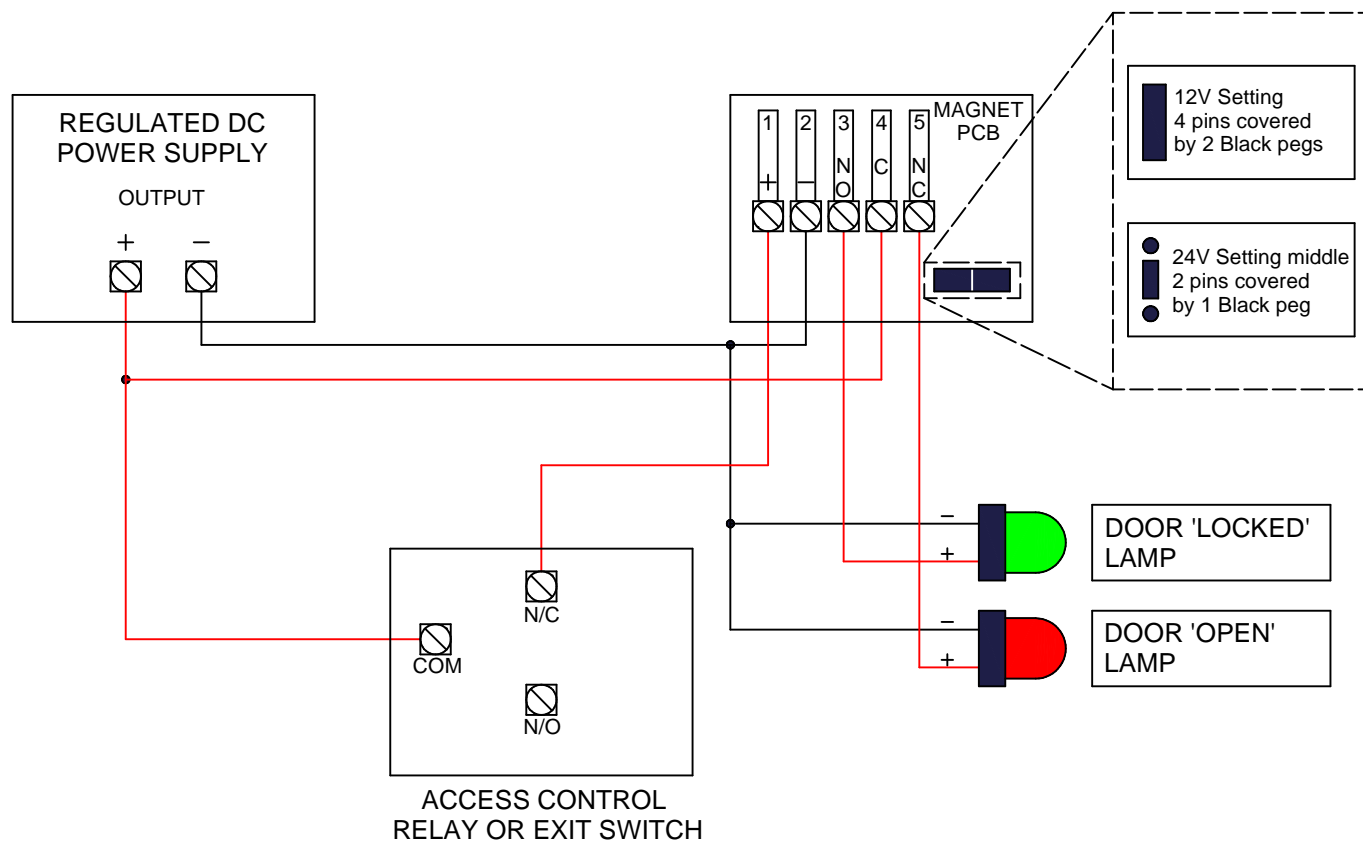

1. Check Magnet PCB is set for correct voltage (Factory setting is 12V).
2. Connect Negative Output (-) from Power Supply to terminal 2 (-) on Magnet PCB.
3. Connect Positive Output (+) from Power Supply to Common of Relay or Exit switch.
4. Connect Normally Closed (N/C) on Relay or Exit switch to terminal 1 (+) on Magnet PCB.
5. Connect Positive Output (+) from Power Supply to terminal 4 (Common) on Magnet PCB.
6. Connect Negative Output (-) from Power Supply to Negative (-) terminal on each Lamp.
7. Connect terminal 3 (NO) to Positive (+) terminal of Lamp (DOOR LOCKED).
8. Connect terminal 5 (NC) to Positive (+) terminal of Lamp (DOOR OPEN).
9. With the door open switch Power supply On and check that the Magnet will hold a screwdriver.
10. Operate the Access Control Relay or Exit switch whilst holding the screwdriver to check magnet is working.
11. If the Screwdriver is released close the door and check the Holding force by pulling / pushing the door.
12. Check that the 2 Lamps are working correctly when the Magnet locks and unlocks.
13. Re-fit the PCB cover plate with M3 18mm Csk Screw (J).