

Instructions for use - please keep for future reference



This lawnmower is sold for DOMESTIC USE ONLY and not for commercial use

IMPORTANT

- 1. When using this lawnmower follow the basic safety precautions, as laid out in this guide, at all times.*
- 2. This lawnmower is for mowing lawns only, do not use other than for its intended use.*
- 3. Keep all the packaging until you are sure that the product is operating correctly.*
- 4. Sharp cutting blades. It is recommended that thick gardening gloves are worn whilst unpacking, assembling, adjusting and maintaining the lawnmower.*

Spares & Support: 01793 333212



CAUTION Safety Information

- Do not use mower if in poor health.
- Do not operate with missing or damaged guards.
- Always wear safety glasses, gloves and closed-toed shoes when operating and maintaining your mower.
- Never place hands, fingers, or feet in the cylinder. When the cylinder is spinning, it can cause serious injuries.
- Always remove debris from path of mower.
- Always have safe footing when using the mower, especially on wet grass or on slopes.
- Use safe lifting practices when moving mower.
- Do not allow children under 12 to use mower.
- Do not operate around children, other people or pets.
- Do not run while using the cylinder mower.
- Do not use mower in areas other than grass.
- Make sure your mower is in safe operating condition by following the tips outlined in this manual.
- Do not use this mower if it becomes damaged.

Advantages of silent mower

- **Long-lasting Stay-Sharp Performance:** Standard cylinder mowers work by rotating the cutting cylinder over a stationary blade. The steel-on-steel contact that is produced creates friction and causes blade wear. As a result, the blades on standard reel mowers dull quickly and require annual sharpening to maintain peak performance. This silent mower uses 'Contact-Less' precision ground, hardened steel blades which greatly reduce friction and blade wear.
- **Easier Single Point, Tool Free Height of Cut Adjustment:** No need to adjust both sides.
- **Larger Cut Height Adjustment Range:** 24-75mm.

Key Components

- 1 Upper Handle
- 2 Middle Handle
- 3 Lower Handle
- 4 Grass Delivery Plate
- 5 Cylinder Assembly
- 6 Drive Wheel
- 7 Roller
- 8 Grass Catcher

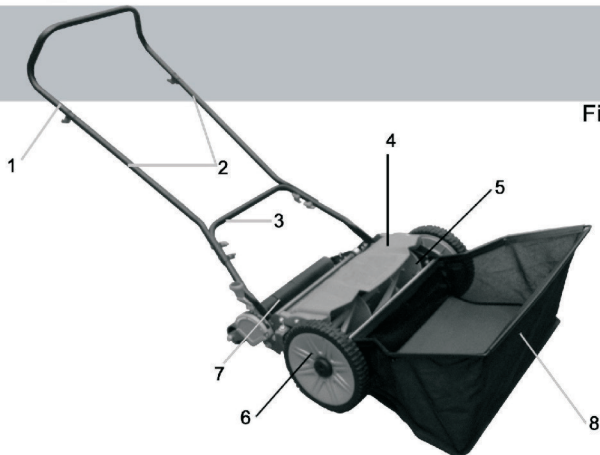

Fig.1

Assembly instructions

Handle Assembly: You do not need any tools to assemble the handle, firstly insert the middle handle into the upper handle. Align the holes and insert bolts and screw the knobs on the bolts, as shown in Fig. 3. Align the holes of the lower handle and middle handle and use the bolts to fasten them. Place the holes of the lower handle onto the handle connecting pin, insert the cir clip into the groove of the handle connecting pin to secure the handle. See Fig.2, 3 and 4.



Fig.2



Fig.3



Fig.4

Grass delivery plate assembly: Place the bottom of the grass delivery plate between the cylinder and the cutter bar. You should attach the top of the grass delivery plate to the left and right side plates, align the hole in the delivery plate and the hole in the side plate and use a screw to fasten it. See Fig.5 and 6.



Fig.5



Fig.6

Grass catcher assembly: Grass catcher is composed of net fabric and steel frame, go through the steel frame into the clip of net fabric. then hang the grass catcher onto the top torsion bar of lawn mower. Grass catcher has two height settings. When the cutting height is set high, the grass catcher should be attached as in "a" in Fig.7; When the cutting height is set low, the grass catcher should be attached as in "b" in Fig.7. See Fig.7, 8 and 9).

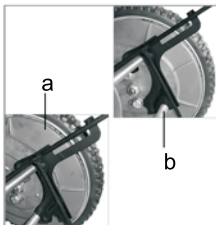

Fig.7



Fig.8



Fig.9

Checking Cutting Performance

IMPORTANT: The stay-sharp cutting system is engineered to cut grass without contact between the blades. This cutting system was precision set during assembly. However, since slippage may possibly occur during shipping, handling, or use, it is very important to check the cutting performance prior to first use and periodically thereafter. Since slippage can occur in two directions, two checks are required to evaluate cutting performance—both checks need to be performed on both the left and right sides of the mower. Checking the cutting performance, and adjusting if needed, are the most important things you can do to ensure that your mower always performs optimally.

Preparation

You'll need several 1" wide strips of standard printer paper (not newspaper) about 8" long and a pair of work gloves

WARNING: The mower blades are sharp. Wear gloves when performing this procedure, and keep fingers away from the cylinder and stationary blade.

Ensure that the mower cannot roll forward by positioning it on a firm, level surface with a block in front of the rear wheels. Then raise the mower to the highest cut height position to improve access.

Check #1: Do the Blades Make Contact?

To check if the blades make contact, face the front of the mower and slowly pull the cutting cylinder downward, one blade at a time, through a full rotation or two. If you hear scraping or feel resistance, skip the remainder of this section and proceed to Adjusting the Blades on page 5.

ATTENTION: If the cutting reel and stationary blade make contact, the mower will be difficult to push and may dull the blade.

Check #2: Do the Blades Cut Properly?

• To check if the blades cut properly you will need to check the blades on both the left and right side of the mower. On the left side, feed a strip of paper up vertically from under the mower between a cutting cylinder blade and the stationary blade. About half an inch of the strip should be visible above the stationary blade.

IMPORTANT: Always place the strip of paper straight up and down, perpendicular to the ground, like a blade of grass.

WARNING: Keep your fingers away from the cutting area.

- Pull the cutting cylinder downward observing whether the paper is cut as the first cutting cylinder blade passes.
- Slide the paper up a half an inch at a time to check the other blades.
- Move to the right side of the mower and check if the blades cut on that side properly.
- If most of the blades cut on both sides, the cutting system is set correctly.

If most of the blades do not cut, the cutting system needs to be adjusted.

Proceed to Adjusting the Blades below.

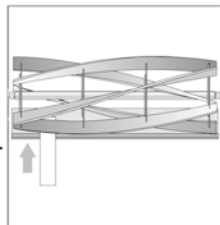

Fig.10

Adjusting the Blades

- Before adjusting the blades, a 13mm open-end wrench is required. (Fig. 11).



Fig.11

- Turn the two locking bolts (A,B) counter-clockwise respectively on the two side plates of your silent mower to loosen (Fig.12).

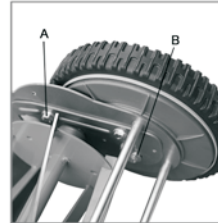

Fig.12

- Adjust the adjustment bolts both on the two sides.
NOTE: Nuts below the bolts will turn while adjusting the adjustment bolts, you don't have to tighten it firmly. If the blades are making contact, turn the dial clockwise while rotating the cutting cylinder, stopping as soon as the blades lose contact. If the blades didn't cut paper, turn the dial counter-clockwise while rotating the cutting cylinder until the blades nearly make contact (Fig.13).

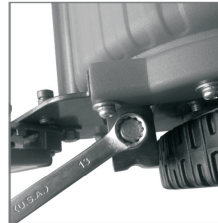

Fig.13

- When properly adjusted, the cutting cylinder and stationary blade should be just short of making contact. When the blades are properly adjusted, firmly tighten the locking bolt(s) on the side(s) you adjusted (Fig.12). If issues still exist on the side(s) of the mower, repeat adjustment steps.

HINT: If you have followed the directions for adjusting the blades, and are still not cutting paper on one or both of the sides of the mower, tighten the locking bolts and take the mower out for a test pass. If the mower cuts to your satisfaction and the blades do not make contact, you have adjusted the mower correctly.

Cutting Height Adjustment

The silent mower offers 9 cutting height settings between 24mm to 75mm. See Fig.14.

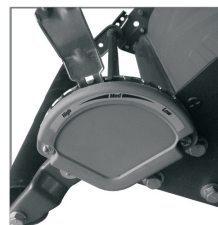

Fig.14

Mowing Tips

Your mower has been designed and engineered to deliver high class cutting performance and a superior mowing experience.

However, there are several basic things you can do when mowing that will greatly impact both your mower's performance and your mowing experience.

If you have used a cylinder mower before, you will immediately appreciate the advantages produced by the mower's advanced cutting technologies and design features.

If this is your first cylinder mower, you will likely require a short transition period as you adjust your mowing habits to maximize efficiency and effectiveness.

The information below will help both experienced and new cylinder mower users achieve all the benefits of the silent mower.

For a healthy lawn, cut off no more than 1/3 of the grass length. To maintain a healthy lawn and avoid the mess created by very long grass clippings, cut off no more than one-third of the grass length at a time. If more than one-third of the length is removed, root growth will be impaired and the grass will be damaged making your lawn susceptible to weeds, disease, and poor appearance. If your lawn gets too high, cut off one third of the length, wait a couple days, and then cut off another third.

To prevent mower damage, clear the mowing area of debris in advance. Before starting, inspect the area to be mowed and remove stones, medium-sized or larger sticks, trash, and other debris.

If you hit hard debris, stop and inspect the blades. If you strike a stone, large stick, or other hard object with the cutting blades, stop mowing immediately and check for a jam or damage. If the blades are damaged, pull the mower backwards to an appropriate work area and follow the instructions in Care and Maintenance on page 7. Continuing to mow with damaged blades may make repair impossible.

To maximise cutting power, walk briskly. The cutting power of the inertia drive cutting reel increases with the speed of the mower. This means that the faster you walk, the better your mower will cut. However, you should not run or mow at an unsafe speed.

For efficient mowing, cut your lawn in long, straight lines. Since reel mowers only cut grass when they are moving, lay out your mowing pattern to maximise the amount of long, straight runs and to minimize starts and stops. Overlapping wheel tracks will ensure a complete and uniform cut (fig.15).

Precut a turnaround zone to ease turns against obstructions. If any mowing runs end against an obstruction (garden, foundation, fence, etc.), begin by making one or two mowing passes along the obstructions to provide a turnaround zone.

For closest edging, use the left side of the mower.

To edge closely against gardens, foundations, fences, and other barriers, use a mowing pattern that positions the left side of the mower toward the barrier.

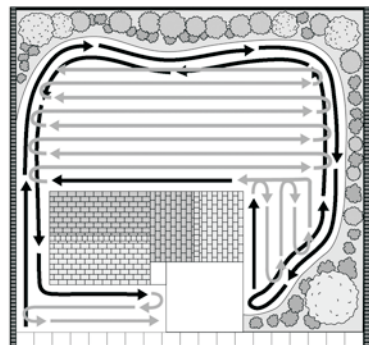

■ Edging and turnaround zone cutting
— General mowing

Care and Maintenance

IMPORTANT: To ensure long lasting performance, protect your mower from impact during use and storage, keep it clean and dry, and practice regular maintenance as follows.

General Maintenance

Keep your mower dry to prevent rust. Your mower will perform better for longer if it is kept dry. The precision ground blade edges of the cutting cylinder and stationary blade and the bearings that carry the cutting cylinder and the rear axle are the most vulnerable to rust. If your mower does get wet, dry it off with a towel and then spray it with a rust preventative as soon as possible.

ATTENTION: Do not use solvents such as mineral spirits or kerosene to clean your cylinder mower. They will damage the plastic

HINT: It is recommended that a silicone based lubricant be used. A lubricant that leaves a dry film instead of an oily or tacky surface is recommended in order to keep dirt, dust and grass clippings from sticking to the cylinder blades.

Keep your mower clean to eliminate potential jams and moisture that could cause rust. Your silent mower will last longer and look better if it is kept clean. After mowing, use a broom or long-bristled brush to clean any grass clippings or other loose debris from the mower – especially around the cutting cylinder and the bottom of the drive system cover. Removing grass clippings prevents cutting and drive system jams and eliminates trapped moisture that could cause rust.

ATTENTION: Do not use a garden hose to wash your mower. Storing the mower wet will allow rust to form.

Lubricate moving parts at least once a season and prior to winter storage to maintain peak performance. Your mower will push easier and last longer if all moving parts are lubricated periodically. It is also recommended that lubrication is applied any time the mower gets wet. Inspect your blades at least once a season and anytime your mower strikes a hard object. While your mower features the cutting system with hardened steel blades, blade damage may still occur if rocks, concrete edges or other hard debris are struck. Before checking for blade damage, ensure that the mower cannot roll forward by positioning it on a firm, level surface with blocked rear wheels. Examine the entire length of the ground edges on all five cutting cylinder blades and the stationary blade. If a dent or ding is found, determine if the ding causes the cutting cylinder and stationary blade to touch. To do this, put on safety gloves and slowly pull the cutting cylinder downward while listening for scraping and feeling for resistance in the area of the ding. If there is no contact, there is no need to repair the ding. Simply treat it with rust preventative and re-inspect periodically in case raised edges appear with continued use.

WARNING: The mower blades are sharp. Wear gloves when performing this procedure, and keep fingers away from the cylinder and stationary blade.

To avoid further damage, repair any ding that causes the cutting reel and stationary blade to touch as quickly as possible. With care, any ding found can be repaired with little or no impact on your mower's cutting performance. Before beginning, get a narrow fine file and position the mower on a firm, level surface with blocked rear wheels to ensure that it cannot roll forward. To remove the ding, file away only enough of the raised material to allow the cutting reel to spin without making contact with the stationary blade. File with long, straight strokes perpendicular to the cutting edge of the blade, trying to avoid removing material from the cutting edge itself. Check if the interstices between the cutting reel and the bedknife are suitable after finishing filing the ding according to the instructions for adjusting the blades.

ATTENTION: Do not use a power tool to repair blades. Too much steel will be removed, resulting in severe blade damage and greatly reduced cutting performance.

Parts Diagram

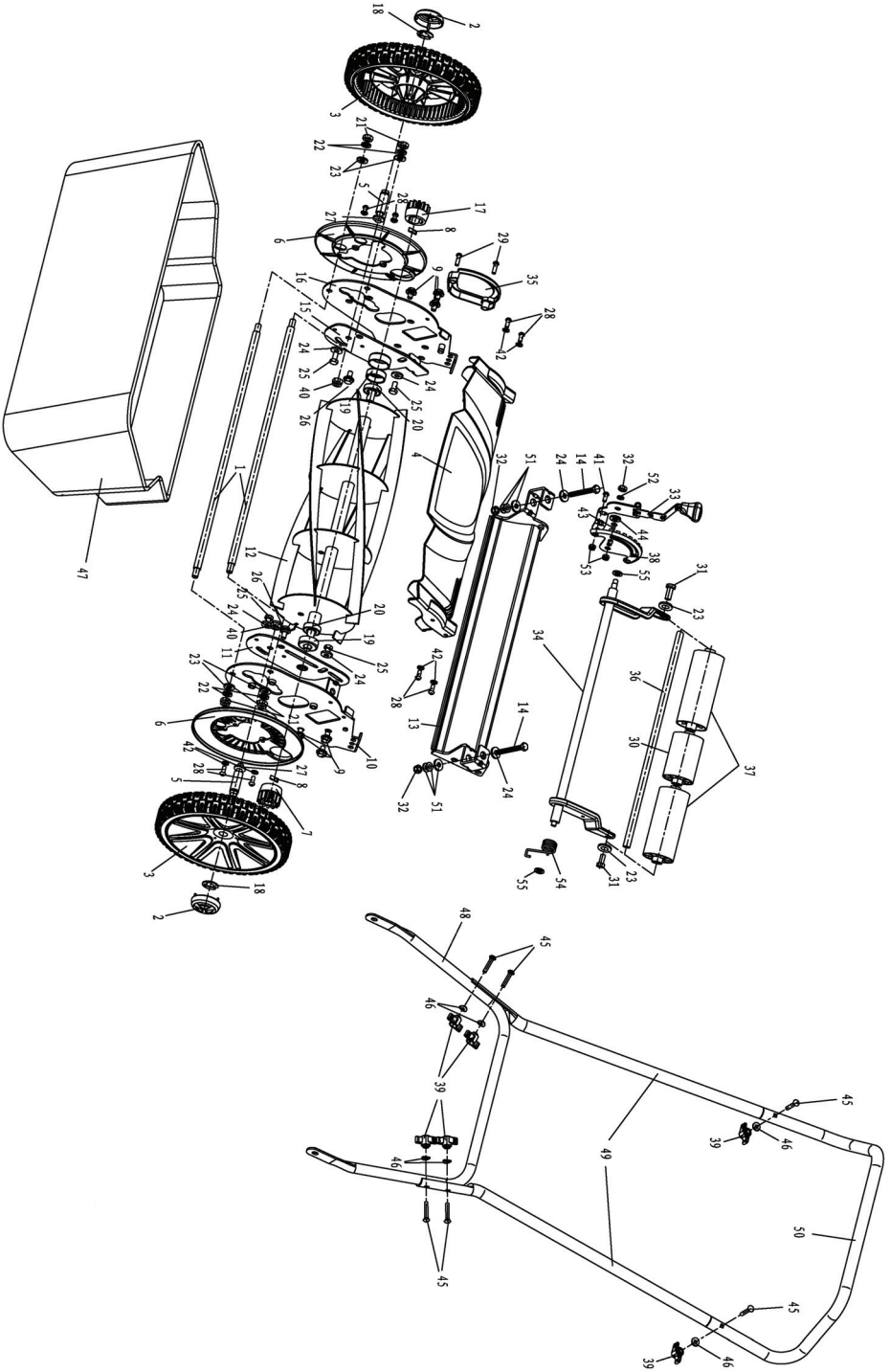

Parts List

PART NO.	ITEM NO.	DESCRIPTION	QTY	PART NO.	ITEM NO.	DESCRIPTION	QTY
WE105-01	1	Side Plate Torsion bar	2	WE105-29	29	"+" Head Bolt M6X20	2
WE105-02	2	Hub Cap	2	WE105-56	30	Roller	1
WE105-03	3	Wheel Assembly	2	WE105-31	31	Bolt	2
WE105-04	4	Grass Delivery Plate	1	WE105-57	32	Lock Nut M8	3
WE105-05	5	Axle	2	WE105-33	33	Wrench Assembly	1
WE105-06	6	Side cover	2	WE105-34	34	Adjuster Height Assembly	1
WE105-07	7	Left Gear	1	WE105-35	35	Adjuster Cap	1
WE105-08	8	Pawl	2	WE105-36	36	Roller Tube	1
WE105-09	9	Cutter Bar Lock Nut	6	WE105-37	37	Roller	2
WE105-10	10	Left Side Plate Assembly	1	WE105-38	38	Roller Adjuster	1
WE105-11	11	Left adjuster plate	1	WE105-39	39	Knob	6
WE105-12	12	Reel Assembly	1	WE105-40	40	Lock Nut M10	2
WE105-13	13	Cutter Bar Assembly	1	WE105-41	41	"+" Head Bolt M6X12	1
WE105-14	14	Hexagan Bolt M8X55	2	WE105-42	42	Washer 6	8
WE105-15	15	Right adjuster plate	1	WE105-43	43	Screw M6X14	1
WE105-16	16	Right Side Plate Assembly	1	WE105-44	44	Washer 10	1
WE105-17	17	Right Gear	1	WE105-58	45	Carriage Bolt M6X35	6
WE105-18	18	E Ring 12	2	WE105-46	46	"U" Washer	6
WE105-19	19	Bearing Cap	2	WE105-47	47	Grass Catcher	1
WE105-20	20	Bearing 6002-2Z	2	WE105-48	48	Lower Handle	1
WE105-21	21	Hex Head Nut M10	4	WE105-49	49	Middle Handle	2
WE105-22	22	Spring washer 10	4	WE105-50	50	Upper Handle	1
WE105-23	23	Washer 10	6	WE105-51	51	Push Bearing	2
WE105-24	24	Washer 8	8	WE105-52	52	Washer 8	1
WE105-25	25	Hex Head Bolt M8X16	4	WE105-53	53	Lock Nut M6	2
WE105-26	26	Bolt	2	WE105-54	54	Spring	1
WE105-27	27	Washer 10	2	WE105-55	55	Plastic Washer	2
WE105-28	28	"+" Head Bolt M6X10	8				

GUARANTEE

This product is guaranteed against manufacturing defects for a period of 24 months. This does not cover the product where the fault is due to misuse, abuse, use in contravention of the instructions, or where the product has been the subject of unauthorised modifications or alterations. This warranty only covers domestic use and will be void if the tool is used for a commercial application.

In the event of a problem with the product within the guarantee period, please contact Customer Service on 01793 333212 or email:

customerservice@webblawnmowers.co.uk

If the issue cannot be resolved over the telephone or by email, you may be referred to your local approved service dealer.

Please keep your sales receipt as proof of purchase

Your statutory rights remain unaffected.

Guarantor: Handy Distribution SN3 4NS

Whilst every effort is made to accurately represent the product, small variations in colour, design and specification may occur. We reserve the right to alter the product without giving notice. All images are illustrative only and may differ from the product due to ongoing product development.





A SELECTION OF QUALITY PRODUCTS FROM OUR VAST RANGE

- **HAND PUSH CYLINDER LAWN MOWERS**
- **ELECTRIC & PETROL CYLINDER LAWN MOWERS**
- **INTERCHANGEABLE CYLINDER CARTRIDGES**
- **ELECTRIC & PETROL ROTARY LAWN MOWERS**
- **PETROL RIDE ON LAWN MOWER**
- **PETROL LAWN SCARIFIER**



FIND OUT MORE AT WWW.WEBBLAWNLOWERS.CO.UK