

Flomate

Flomate Mains Boost Pump Installation & Maintenance Instructions

Please leave this instruction booklet with the owner as it contains important guarantee, maintenance and safety information



PRODUCT DESCRIPTION

Electric motor driven peripheral pump with bypass, complete with an automatic control system consisting of flow switch and electronic control.

APPLICATION

The Flomate is a mains booster pump with an automatic control system for domestic use, designed to assist the pressure from the mains supply, where the mains pressure is insufficient. This unit requires a minimum unassisted supply flow of 0.6 l/min to operate. The pump is limited to producing a maximum flow of not greater than 12 l/min, and a maximum pressure of 3.0 bar.

When the flow/pressure from the rising main exceeds the pump output, the **patented** applied for integral bypass will direct the water into the system as normal.

The Flomate mains booster is a patent granted design.

Please note the following warning signs.



Warning of possible electrical hazard.



- **Possible danger to personnel or important installation requirement.**
- **All the safety and operating instructions in this booklet must be followed.**
- **The pump must not be used for any other application without the written consent of Stuart Turner Limited.**
- **The pump must be installed by a qualified person.**
- **The pump is not suitable for heavy commercial/industrial applications.**
- **The installation must comply with the latest Building Regulations, Wiring Regulations (BS 7671) and Water Supply Regulations (see notes).**
- **This appliance can be used by children aged from 8 years and above and persons with reduced physical, sensory or mental capabilities or lack of experience and knowledge if they have been given supervision or instruction concerning use of the appliance in a safe way and understand the hazards involved. Children shall not play with the appliance. Cleaning and user maintenance shall not be made by children without supervision.**
- **Children should be supervised to ensure that they do not play with the appliance.**

Notes



- **This product must be installed in accordance with the current Water Supply (Water Fittings) Regulations.**
- **Under no account should the internal flow restrictor be removed, or replaced with an alternative design.**

Cont ...



- **The flow restrictor must be replaced every 2 years.**
- **Care must be taken to ensure the maximum pressure generated by the pump combined with the incoming mains water pressure does not exceed the pumps maximum operating pressure of 6 bar.**

Please read installation details carefully as they are intended to ensure this product provides long, trouble free service. Failure to install the unit in accordance with the installation instructions will lead to invalidation of the warranty.

STORAGE

If this product is not to be installed immediately on receipt, ensure that it is stored in a dry, frost and vibration free location in its original packaging.

CONTENTS

	Page
Checklist	4
Important Facts - read before commencing installation	5
Location	6
Electrical Installation	8
Priming	10
Maintenance	10
Technical Specification	11
Trouble Shooting	12
Guarantee	14

CHECKLIST

IMPORTANT: With the pump removed from its packaging check for any damage prior to installation. If any damage is found contact Stuart Turner Ltd within 24 hours of receipt.

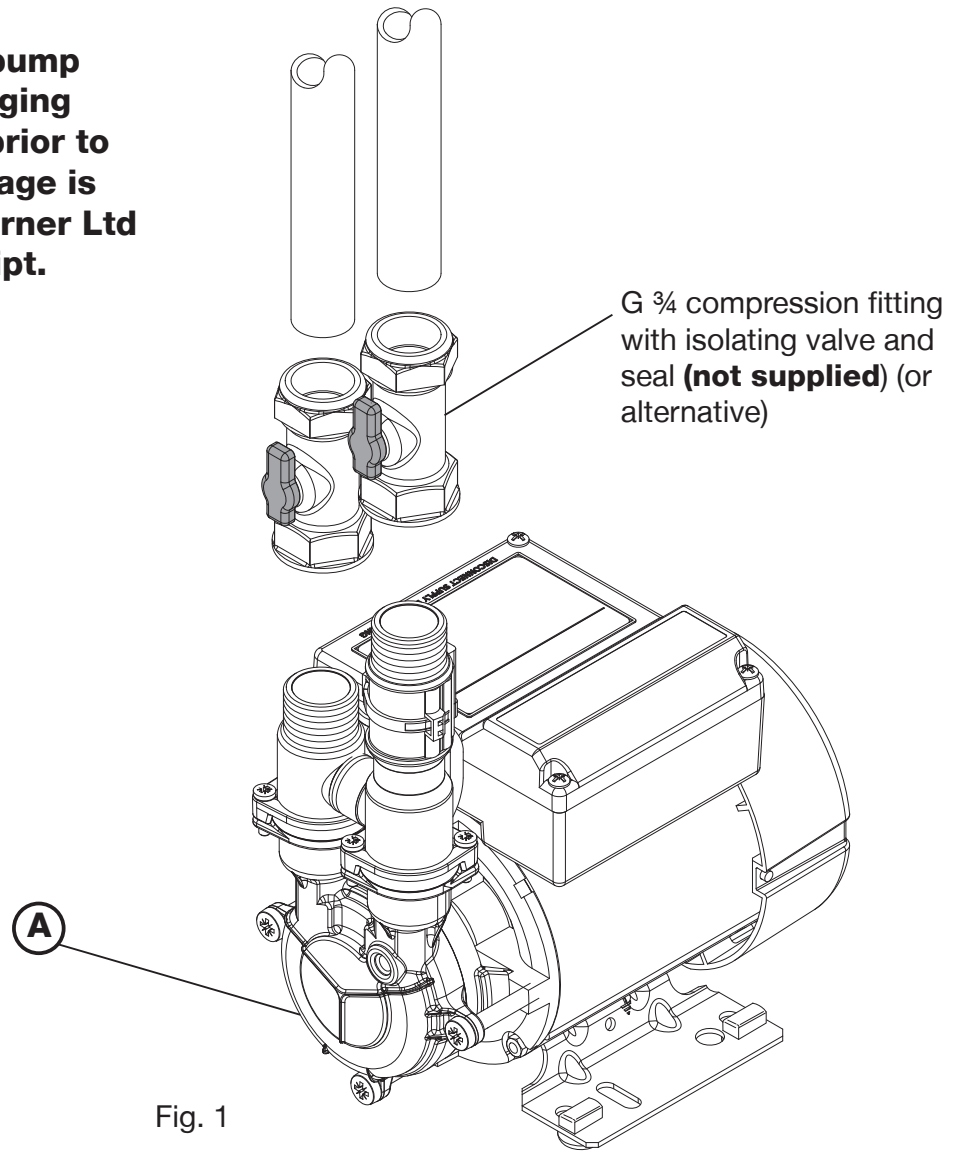

Item	Description	Qty
(A)	Pump	1

Your product may vary slightly from the picture above.

Cont ...

1 READ BEFORE COMMENCING PUMP INSTALLATION

A. Water temperature

The water entering the pump must be controlled as follows:

1.11 The maximum allowable water temperature is 35 °C.

1.12 The minimum allowable water temperature is 4 °C.

B. Pipework - General

1.13 **Secure pipework:** Ensure pipework to and from pump is independently supported & clipped to prevent forces being transferred to inlet and outlet branches of pump.

1.14 **Flux:** Solder joints must be completed and flux residues removed prior to pump installation (**flux damage will void any warranty**).

1.15 **Pipework design:** Care should be taken in the design of pipework runs to minimize the risk of air locks e.g. use drawn bends rather than 90° bends.



1.16 **DO NOT** introduce solder flux to flexible hoses, pumps or pump parts.

1.17 **DO NOT** allow contact with oil or cellulose based paints, paint thinners or strippers, acid based descalents or aggressive cleaning agents.

1.18 **Water flow:** An un-assisted flow rate of at least 0.6 l/min is required through the outlets to be pumped in order to make this pump work.

C. Plumbing & Electrical Installation Regulations

1.19 The plumbing installation must comply with “The Water Supply (Water Fittings) Regulations 1999” and “BS 6700” building regulations.

2 LOCATION - GENERAL



- 2.11 **Access:** For emergencies and maintenance the pump must be easily accessible.
- 2.12 **Protection:** The pump must be located in a dry position, frost free and protected from freezing. Ensure the pump is in a dry position, away from heat sources, such as radiators and heaters.
- 2.13 **Ventilation:** Ensure an adequate air flow to cool the pump. Separate the pump from other appliances that generate heat. An 80 mm air gap must be maintained to allow free air flow through the fan cowl and over the motor at all times.
- 2.14 **Safety:** The motor casing can become very hot under normal operating conditions. Care must be taken to ensure it cannot be touched during operation.
- 2.15 **Water retention:** Site the pump in a location where in the unlikely event of a water leak, any spillage is contained or routed to avoid electrics or areas sensitive to water damage.
- 2.16 **Location point:** The pump **must** be located after the mains water stop cock, in-line to the connection to the boiler. Do not site the pump in the roof space, since air locks can easily result.
- 2.17 **Pump position:** The pump must be positioned on its anti-vibration mounting feet and as close to the water source as possible.
- 2.18 **Direction of flow:** Ensure the water flow is in the direction of the arrow, as marked on the flow switch reed clamp.

2.19 Pipework Connections:



Isolating valves: Always install isolating valves (not supplied) to both suction and delivery pipe to aid future maintenance.

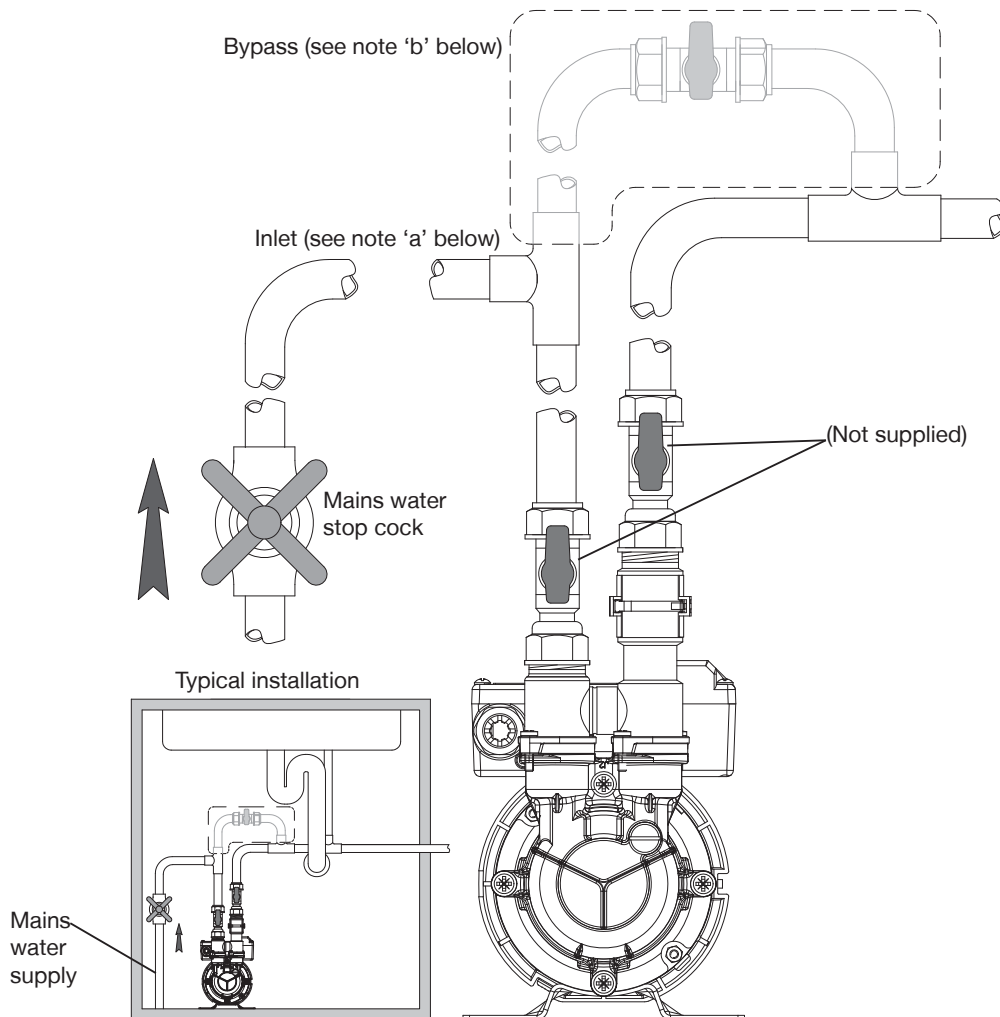

Fig. 2

- Incoming mains pressure can vary, but must never exceed 6 bar. If there is a possibility of exceeding 6 bar, separate inlet pressure control must be fitted.
- It is advisable to fit a bypass pipe and isolating valves. This will allow removal of the pump for maintenance and servicing, and ensure the water supply into the property is still available during that period (Fig. 3).

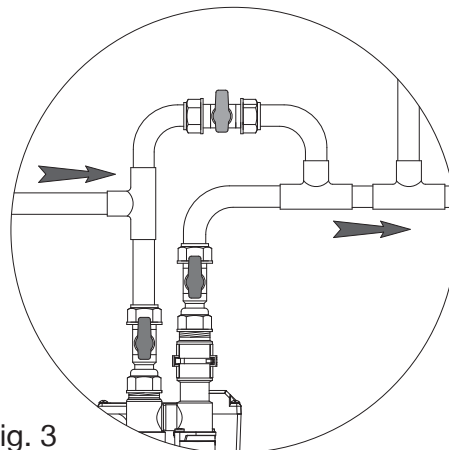

Fig. 3

3 ELECTRICAL INSTALLATION / EARTHING



- 3.11 **Regulations:** The electrical installation must be carried out in accordance with the current national electrical regulations and installed by a qualified person.
- 3.12 **Safety:** In the interests of electrical safety a 30 mA residual current device (**R.C.D. not supplied**) must be installed in the supply circuit. This may be part of a consumer unit or a separate unit.
- 3.13 Before starting work on the electrical installation ensure the power supply is isolated.
- 3.14 The motor and wiring must not be exposed to water.
- 3.15 The supply cable must be positioned so that it is not stepped on, cut or damaged.
- 3.16 **Electrical Connection:**
- The pump is provided with a factory fitted supply cord.
 - This must be permanently connected to the fixed wiring of the mains supply.
 - Means for disconnection must be incorporated in the fixed wiring in accordance with the wiring regulations.
 - A suitable method of connection would be via a dedicated double pole switched, fused connection unit complying with BS 1363-4, protected with a fuse (see technical specification section).
 - The connection unit should be mounted in an easily accessible position and should be labelled if confusion is possible, to allow easy identification of the flomate isolating switch.
- 3.17 **Earthing:** This appliance must be earthed via the supply cord, which must be correctly connected to the earth point located in the terminal box.
- 3.18 **Additional earthing:** Certain installations may require additional earthing arrangements such as equipotential bonding. Reference should be made to the relevant regulations concerning this subject to ensure compliance.
- 3.19 **Wiring Of Connection Unit:**



WARNING: This appliance must be earthed.

The wires in the mains lead (supply cord) are coloured in accordance with the following code:

Green and Yellow:- Earth. Blue:- Neutral. Brown:- Live

As the colours of the wires in the mains lead of this appliance may not correspond with the coloured markings identifying the terminals in your connection unit proceed as follows:

- Green and yellow wire must be connected to the terminal in the connection unit which is marked with the letter 'E' or by the earth symbol \oplus or coloured green or green and yellow.
- Blue wire must be connected to the terminal which is marked with the letter 'N' or coloured black.
- Brown wire must be connected to the terminal which is marked with the letter 'L' or coloured red.

Cont ...

3.20 Wiring Diagram:



The supply cord and internal wiring within the terminal box are routed and secured to ensure compliance with the electrical standard EN 60335-1. Do not disturb the internal wiring or factory routing and securing of all internal wiring.

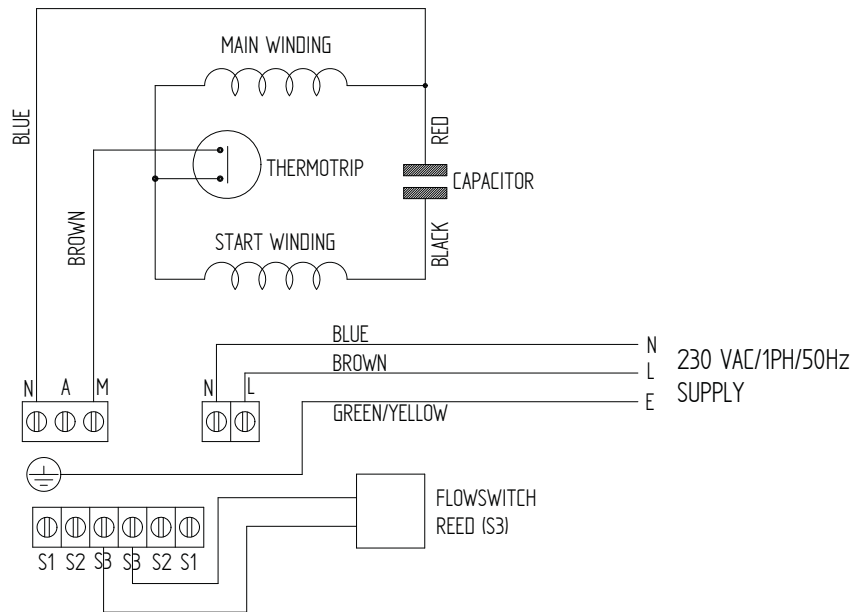

Fig. 4

3.21 Fuse:

Model	Fuse Size (AMPS)
All Models	5

4 PRIMING

4.11 **Priming:** This pump is self venting. Open the mains stopcock and allow the pump to fill and vent, please note the pump chamber must be full of liquid at all times. Seal damage will result if the pump runs dry. **Do not run the pump dry.**

4.12 **Starting:**

- a) Ensure all outlets are closed, turn power supply 'on'.
- b) Open and close all outlets in turn associated with the pump allowing liquid to flow from each outlet until all air is purged. As each outlet is opened and closed the pump will start and stop respectively.
- c) Any tap or control valve within the system when opened and closed will now turn the pump on/off. Check system for leaks, if clear the system is now operating correctly
- d) Carefully check pump and pipework for leaks whilst pump running and stationary before leaving the installation unattended.

4.13 **For Further Technical Support:** Phone the Stuart Turner PumpAssist team on +44 (0) 844 98 000 97. Our staff are trained to help and advise you over the phone.

Note: When pumps are installed in another manufacturers original equipment, please contact the manufacturer for advice.

5 MAINTENANCE

5.11 Disconnect electrical supply before working on pump.

5.12 Turn off liquid supplies to the pump and release pressure by opening outlets before attempting maintenance.

5.13 The flow restrictor inside the pump must be replaced every **2 years** (contact Stuart Turner Ltd).

5.14 No other routine maintenance is required.

5.15 After maintenance is completed, refer to Section 4 - Commissioning for instructions on restarting pump.

6 TECHNICAL SPECIFICATION

Pump Model		Flomate Mains Boost 46574
General	Guarantee	3 years
	WRAS approval	1210040
Features	Pump type	Peripheral
	Mechanical seal	Nitrile / Carbon / Silicon Carbide
	Anti-vibration feet	✓
	Dry run protection	✓
Performance	Maximum head (closed valve)	3.2 bar
	Maximum flow	12 l/min
	Maximum working pressure*	600 kPa (6 bar)
	Maximum ambient air temperature	40 °C
	Min / Max water temperature	Min 4 °C / Max 35 °C
	Flow switch sensitivity (approx)	0.6 l/min
Connections	Pump connections	G ¾ male
Motor	Type	Induction, auto-reset thermal trip
	Duty rating	Continuous (S1)
Electrical	Power supply / phase / frequency	230 V a.c. / 1 / 50 Hz
	Current (full load)	1.7 Amps
	Power consumption	380 Watts
	Fuse rating	5 Amps
	Power cable (pre-wired)	1.5 metres
Physical	Enclosure protection	IPX4
	Length	210 mm
	Width	130 mm
	Height (excluding hoses)	231 mm
	Weight (including fittings)	5.2 Kg

Stuart Turner reserve the right to amend the specification in line with its policy of continuous development of its products.

*Note: The maximum pressure that can be applied to the pump under any installation conditions.

Cont ...

7 TROUBLE SHOOTING GUIDE

Symptoms	Probable Cause	Recommended Action
Pump will not start.	<p>No water.</p> <p>Water supply.</p> <p>Electrical supply.</p> <p>Faulty reed switch/PCB</p> <p>Internal motor thermotrip activated.</p>	<p>Check required flow of liquid is available to the fittings of approx. 0.6 l/min.</p> <p>Check water supply from mains and all stopcocks are open.</p> <p>Check wiring connections. If flow exists inline with requirements - check that all electric switches are on. Is the correct fuse fitted? Check circuit breaker is set.</p> <p>Refer to circuit test as detailed in Fig. 5.</p> <p>Wait for thermotrip to auto reset and check that duty point and run time is within specification (see Technical Section).</p>
<p>Pump starts when outlets are off.</p> <p>or</p> <p>Pump cycles (hunts) on/off frequently.</p>	Leak in system	Check tap washers, w/c valve washers, pipe joints.
Pump runs on when all terminal outlets are closed.	<p>Leak in system.</p> <p>Reed clamp out of position.</p> <p>Jammed flow switch.</p> <p>Faulty reed switch or P.C.B.</p>	<p>Check tap washers, w/c valve washers, pipe joints.</p> <p>Ensure reed clamp is fitted correctly in location groove (Fig. 5).</p> <p>Remove flow switch reed clamp whilst pump is running. If pump stops proceed to isolate the pump electrically and hydraulically and remove brass housing that contains float. Check for free movement.</p> <p>Remove flow switch reed clamp whilst pump is running. If pump continues to run, this indicates a closed circuit in either the flow switch reed or P.C.B. in the terminal box, these should be checked electrically.</p>

Cont ...

7.11 Flow Switch Circuit Test:

1. First confirm visually that the flow switch reed clamp has not been dislodged during handling or installation. The clamp must be fully located within its flow switch body groove as shown.
2. To carry out the following test you will need to obtain a magnet, a typical fridge magnet is suitable.
3. Ensure the power supply is switched on.
4. Position the magnet directly in front of the reed clamp as shown. If pump does not start, then slowly move the magnet up and down to a position that exceeds the extent of the reed clamp. The pump should instantaneously start at some point during this extent of movement. If this does not happen, this indicates a possible fault with the reed switch or the P.C.B which is located within the terminal box. These should be checked electrically. Consult Stuart Turner for further instructions.

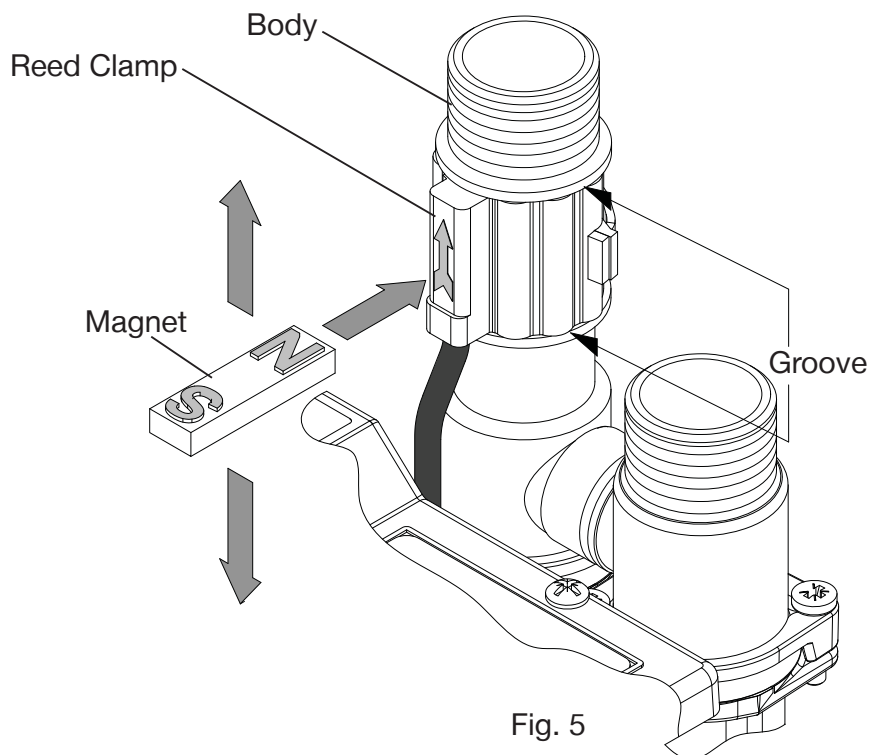

- 7.12 **Environment Protection:** Your appliance contains valuable materials which can be recovered or recycled. At the end of the products' useful life, please leave it at an appropriate local civic waste collection point.

Cont ...

8 THE FLOMATE GUARANTEE

Congratulations on purchasing a Stuart Turner pump.

We are confident this pump will provide many years of trouble free service as all our products are manufactured to the very highest standard.

The Flomate Pump is guaranteed to be free from defects in materials or workmanship for 3 years from the date of purchase.

Within the guarantee period we will repair, free of charge, any defects in the pump resulting from faults in material or workmanship, repairing or exchanging the whole unit as we may reasonably decide.

Not covered by this guarantee: Damage arising from incorrect installation, improper use, unauthorised repair, normal wear and tear and defects which have a negligible effect on the value or operation of the pump.

Reasonable evidence must be supplied that the product has been purchased within the guarantee term prior to the date of claim (such as proof of purchase or the pump serial number).

This guarantee is in addition to your statutory rights as a consumer. If you are in any doubt as to these rights, please contact your local Trading Standards Department.

In the event of a claim isolate the unit and then please telephone '**PumpAssist**'.

+44 (0) 844 98 000 97

Proof of purchase should accompany the returned unit to avoid delay in investigation and dealing with your claim.

You should obtain appropriate insurance cover for any loss or damage which is not covered by Stuart Turner Ltd in this provision.

Please record here for your records.

TYPE NO.	SERIAL NO.	DATE PURCHASED

Installers – Register with Stuart Turner and move up to Approved Installer status

We receive thousands of enquiries every month from people seeking a Stuart Turner installer and by registering your details with us, we can offer consumers the opportunity to quickly locate an installer in their area.

Registration is free - simply click on the **'register as an installer'** link on our homepage at **www.stuart-turner.co.uk** and complete a short form which will enable visitors to find your contact details on our web site 'installer finder'. Alternatively use your smartphone to scan this QR code and go straight to the form.



We'll do the rest!

In addition we will ensure you receive advance notice on all new product launches and access to any special offers or promotions.

Following initial registration, Stuart Turner offers a professional training programme, enabling you to achieve Approved Installer status and opening the door to a range of additional benefits.

Contact approvedinstaller@stuart-turner.co.uk for further details.



DECLARATION OF CONFORMITY

2006/42/EC

BS EN ISO 12100-1, BS EN ISO 12100-2, BS EN 809

2006/95/EC

BS EN 60335-1, BS EN 60335-2-41

2004/108/EC

BS EN 55014-1, BS EN 55014-2, BS EN 55022, BS EN 61000-3-2, BS EN 61000-3-3,
BS EN 61000-4-2, BS EN 61000-4-3, BS EN 61000-4-4, BS EN 61000-4-5, BS EN 61000-4-6,
BS EN 61000-4-11

1999/519/EC

BS EN 62233

2011/65/EU

IT IS HEREBY CERTIFIED THAT THE STUART ELECTRIC MOTOR DRIVEN PUMP AS SERIAL NUMBER BELOW, COMPLIES WITH THE ESSENTIAL REQUIREMENTS OF THE ABOVE E.E.C. DIRECTIVES.



RESPONSIBLE PERSON
AND MANUFACTURER

STUART TURNER LIMITED
HENLEY-ON-THAMES, OXFORDSHIRE
RG9 2AD ENGLAND.

Signed.....

Business Development Director

Stuart Turner are an approved company to BS EN ISO 9001:2000



Stuart Turner Ltd, Henley-on-Thames, Oxfordshire RG9 2AD ENGLAND

Tel: +44 (0) 1491 572655, Fax: +44 (0) 1491 573704

info@stpumps.co.uk www.stuart-turner.co.uk