

Mira Vision

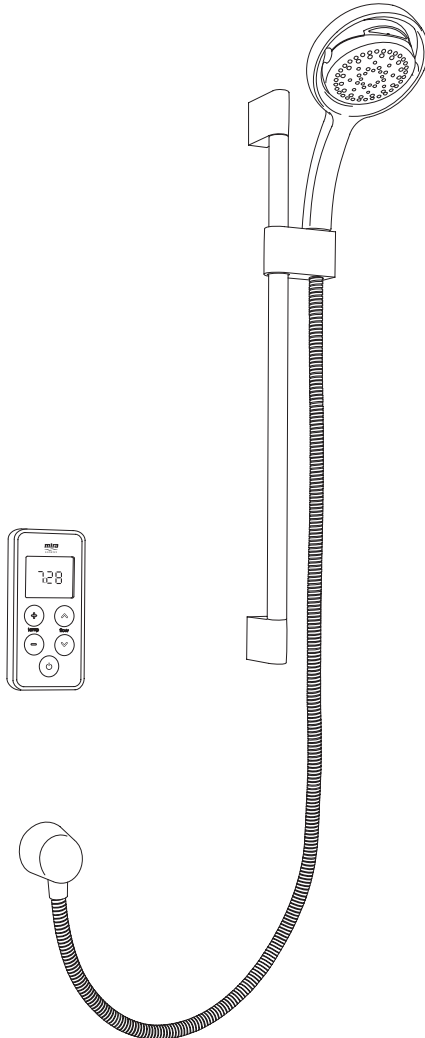

These instructions must be left with the user

Installation Guide

Showering perfection

mira
SHOWERS

CONTENTS

Introduction.....	3
Products Covered by this Guide.....	3
Guarantee	3
Patents and Design Registration.....	3
Important Safety Information	4
Pack Contents	6
Specifications	9
Standards and Approvals	9
Dimensions.....	11
Installation	12
General.....	12
Important Information Regarding Radio Controlled Devices.....	12
Installation Schematic	16
Position and Signal Test	18
Shower Fittings - Ceiling Fed	21
Shower Fittings - Rear Fed	24
Wireless Controller	28
Commissioning.....	29
Re-Registering	31
Fault Diagnosis.....	32
Maintenance	36
Spare Parts	37
Accessories	40
Disposal and Recycling	41
Notes	42
Customer Service.....	44

If you experience any difficulty with the installation or operation of your new shower, then please refer to the **Fault Diagnosis** section, before contacting **Kohler Mira Ltd.**
Our telephone and fax numbers can be found in the back of this guide.

INTRODUCTION

Thank you for purchasing a quality Mira product. To enjoy the full potential of your new product, please take time to read this guide thoroughly. Having done so, keep it handy for future reference.

The Mira Vision Mixer Valve is designed to be used with the Mira Vision showerhead and fittings.

Products Covered by this Guide

Mira Vision Digital Mixer - High Pressure/Combi Valve

Mira Vision Digital Mixer - Pumped Valve.

Mira Vision Wireless Controller.

Mira 360 Fittings (Ceiling Fed or Rear Fed).

Guarantee

For domestic installations, Mira Showers guarantee the Mira Vision against any defect in materials or workmanship for a period of five years from the date of purchase (shower fittings for one year).

For non-domestic installations, Mira Showers guarantee the Mira Vision against any defect in materials or workmanship for a period of one year from the date of purchase.

For terms and conditions refer to the back cover of this guide.

Recommended Usage	
Domestic	✓
Light Commercial	✗
Heavy Commercial	✗
Healthcare	✗

Patents and Design Registration

Design Registration	001295935
Patents	GB: 2 421 297 USA: 7 669 776
Patent Applications	WO: 2009/022112 EUROPE: 2 227 647 USA: US-2010 - 0282 326 - A1 CHINA: CNI01918743A INDIA: 1306/MUMNP/2010

IMPORTANT SAFETY INFORMATION

Warning!

Follow all warnings, cautions and instructions contained in this guide, and on or inside the appliance.

1. THIS APPLIANCE MUST BE EARTHED. ENSURE SUPPLEMENTARY BONDING COMPLIES WITH THE "REQUIREMENTS FOR ELECTRICAL INSTALLATIONS". The Mira Digital Mixer Valve is intended to be permanently connected to the fixed electrical wiring of the mains system. A means for electrical isolation of the appliance shall be provided in the fixed wiring in accordance with local wiring regulations.
2. Products manufactured by us are safe and risk-free, provided that they are installed, used and maintained in good working order, in accordance with our instructions and recommendations.
3. Isolate the electrical and water supplies before connecting to the appliance.
4. This appliance must be provided with means for disconnection that is incorporated into the fixed wiring in accordance with the relevant local wiring regulations.
5. Refer to the wiring diagram before making any electrical connections.
6. Mains connections are exposed when the cover of the Digital Mixer Valve is removed.
7. The Digital Mixer Valve must not be installed where it can become frozen.
8. Make sure that any pipework that could become frozen is properly insulated.
9. In accordance with BS7671 a 30mA Residual Current Device (RCD) should be included in the electrical circuit. This may be part of the consumer unit or a separate unit.
10. All pipework must be checked for leaks before the product installation is completed. The product should be pressurised and both inlet & outlet connections inspected.
11. If the shower is dismantled during installation or servicing then upon completion the product must be inspected to ensure all electrical connections are tight and that there are no leaks.
12. Having completed the installation, make sure that the user is familiar with the operation of the appliance.
13. **DO NOT** commission this appliance if water leaks from the unit.
14. Only Mira recommended outlet fittings should be used.
15. Ensure all electrical connections are tight, to prevent overheating.
16. This product is not suitable for areas with high humidity (i.e steam rooms). Please consult your installer.
17. The water supplies to this product must be isolated if the product is not to be used for a long period of time. If the product or pipework is at risk of freezing during this period they should also be drained of water.

Caution!

1. Read all of these instructions and retain this guide for later use.
2. The electrical installation must comply to “BS 7671 - Requirements for Electrical Installations” commonly referred to as the IEE Wiring Regulations, or any particular regulations and practices, specified by the local electricity supply company.
3. The plumbing installation must comply with the requirements of UK Water Regulations / By-laws (Scotland), Building Regulations or any particular regulations and practices, specified by the local water company or water undertakers.
4. Make sure that you fully understand how to operate this shower and make sure that it is properly maintained in accordance with the instructions given in this manual.
5. Children should be supervised to make sure that they do not play with the appliance.
6. Anyone who may have difficulty understanding or operating the controls of the shower should be supervised whilst showering.

Particular consideration should be given to:

- The young
 - The elderly
 - The infirm
 - The disabled
 - Anyone who suffers from a medical condition that can result in temporary incapacity (e.g. Epilepsy or blackouts).
 - Anyone inexperienced in the correct operation of the controls.
7. The appliance is not intended for use by persons (including children) with reduced physical, sensory or mental capabilities, unless they are supervised or have been given instruction concerning the use of the appliance by a person responsible for their safety. Sunburn or skin conditions can increase your sensitivity to hot water. Make sure that you set the shower to a cooler temperature.
 8. If any of the following conditions occur, isolate the electricity and water supplies and refer to section “**To contact us**”, in the back cover of this guide.
 - If the cover is not correctly fitted and water has entered the appliance case.
 - If the case is damaged.
 - If the appliance begins to make an odd noise, smell or smoke.
 - If the appliance shows signs of a distinct change in performance, indicating a need for maintenance.
 9. **DO NOT** operate if water leaks from the appliance.
 10. **DO NOT** operate this appliance if it is frozen. If suspected of being frozen, isolate and contact us for advice.

PACK CONTENTS

Tick the appropriate boxes to familiarise yourself with the part names and to confirm that the parts are included.

Documentation

- 1 x Wireless Controller User Guide
- 1 x Showerhead User Guide
- 1 x Customer Support Brochure

Digital Mixer Valve

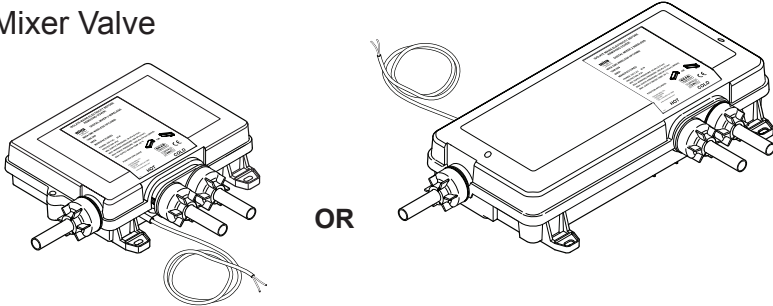

Digital Mixer -

High Pressure/Combi Valve

Digital Mixer - Pumped Valve

 3 x Fixing Screws

 3 x Wall Plugs

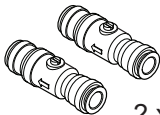
 2 x Push-Fit Isolators

 1 x Outlet Connector

Wireless Controller

1 x Wall Plate



1 x Battery Cover



 2 x Fixing Screws

 2 x Wall Plugs

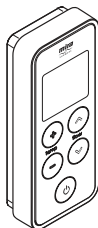

1 x Wireless Controller



3 x AA Batteries

Ceiling Fed Fittings

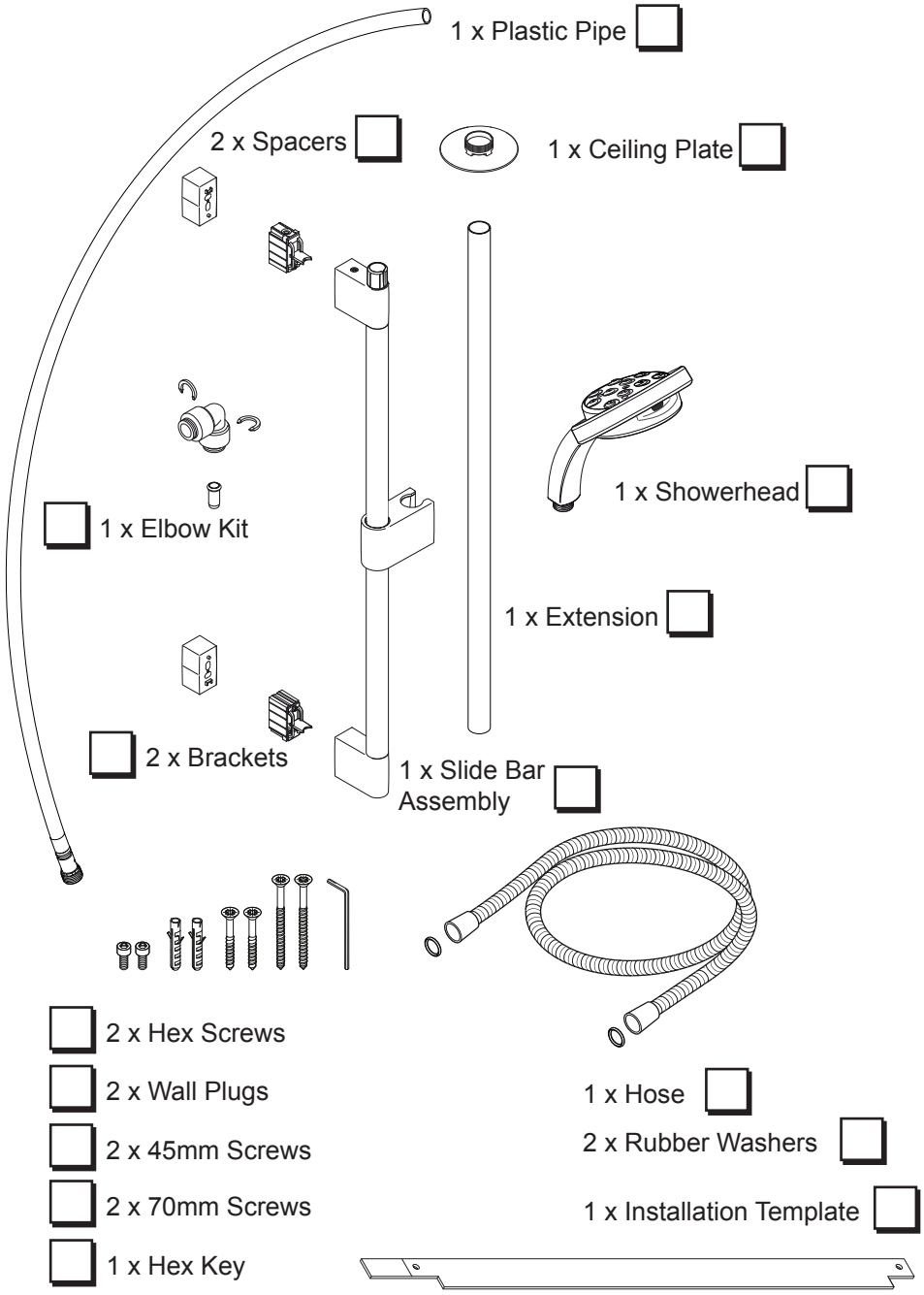

Rear Fed Fittings

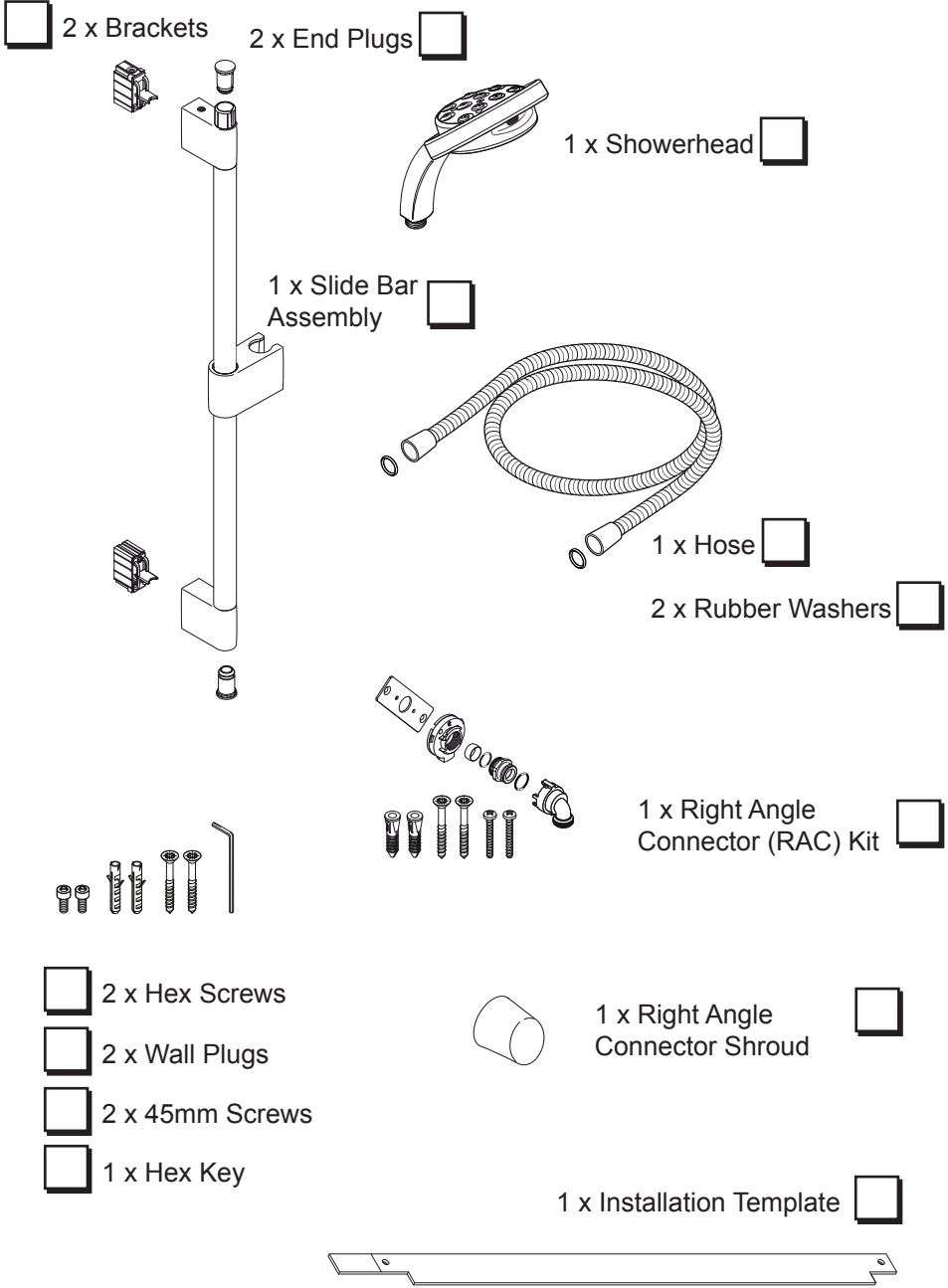

SPECIFICATIONS

Standards and Approvals

The Mira Vision complies with all relevant directives for CE marking. The Mira Vision is a type 1 electronic, independently mounted control for surface mounting. The Mira Vision is in compliance with the essential requirements of the R&TTE directive 1999/5/EC. A copy of the declaration of conformity may be obtained by contacting Kohler Mira Limited, U.K customer services department.

General

Pollution Degree	2
Rated Impulse Voltage	2.5 kV
Suitable for Drinking	Not Suitable
Connections	15 mm Compression/Pushfit

Mira Digital Mixer Valve High Pressure

Pressures	
Maximum Static Pressure	1000 kPa (10 bar) = 100 m max. total head
Maximum Maintained Pressure	500 kPa (5 bar) = 50 m max. total head
Minimum Maintained Pressure	50 kPa (0.5 bar) = 5 m max. total head
Supply Pressure Differential	Nominally Equal
Temperatures	
Maximum Temperature (factory preset)	45 °C
Maximum Temperature (setting range)	35 °C - 48 °C
Minimum Temperature	Thermostatic control down to 30 °C
Hot Water Range	55 °C - 65 °C
Cold Water Range	1 °C - 20 °C
Temperature Stability	± 1 °C at recommended supply conditions
Ambient Temperature	1 °C - 40 °C
Maximum Relative Humidity	95% non-condensing
Flow Rates and Times	
Nominal Flow Rates (will vary depending on inlet maintained pressure and spray mode)	Max @ 1.0 bar = 16l/min Min @ 1.0 bar = 5l/min
Electrical	
Supply Voltage	230V AC 50 Hz
Maximum Load	20W

Mira Digital Mixer Valve Pumped

Pressures	
Maximum Static Pressure	100 kPa (1 bar) = 10 m max. total head
Maximum Maintained Pressure	100 kPa (1 bar) = 10 m max. total head
Minimum Maintained Pressure	1 kPa (0.01 bar) = 0.1 m min. total head
Supply Pressure Differential	Nominally Equal
Temperatures	
Maximum Temperature (factory preset)	45 °C
Maximum Temperature (settable range)	35 °C - 48 °C
Minimum Temperature	Thermostatic control down to 30 °C Full Cold also selectable
Hot Water Range	50°C - 65°C
Cold Water Range	1°C - 20°C
Temperature Stability	± 1°C at recommended supply conditions
Ambient Temperature	1°C - 40°C
Maximum Relative Humidity	95% non-condensing at 30 °C
Flow Rates and Times	
Flow Rates (will vary depending on inlet maintained pressure and spray mode)	Max @ 0.01 bar = 16 l/min Min @ 0.01 bar = 6 l/min
Electrical	
Supply Voltage	230V AC 50 Hz
Maximum Load	200 W at 230V AC

DIMENSIONS

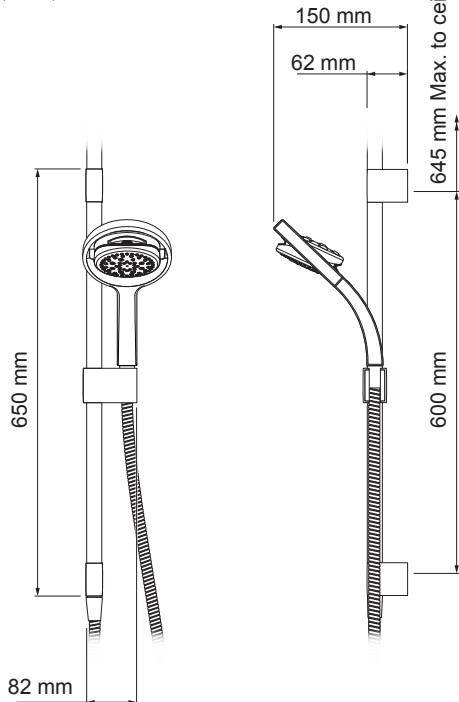
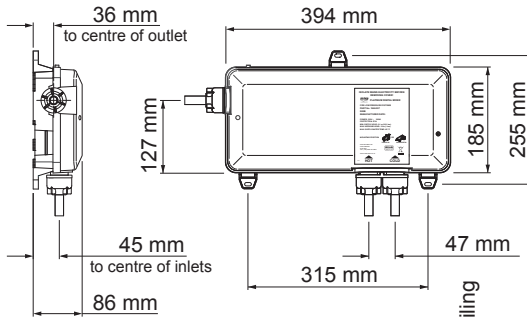
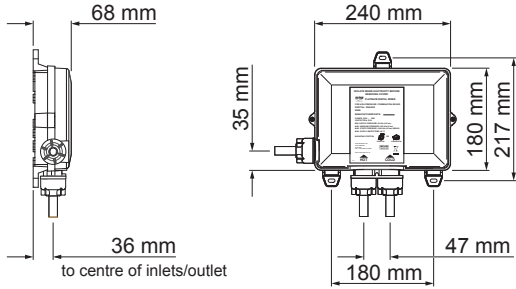

INSTALLATION

General

The installation must be carried out in accordance with these instructions, and must be conducted by designated, qualified and competent personnel.

The Digital Mixer Valve may be installed in a loft space, under the bath or in a convenient cupboard space provided there is enough room for maintenance (e.g. Removal of Digital Mixer Valve lid). Failure to do so may result in an inability to carry out any maintenance. Safe and easy access to the product should be available at all times.

When installing a mixer valve in an area not regularly accessed, consideration for potential leaks must be taken into account. While such events are unlikely, it is advisable to periodically check the installation for traces of water on or around the product. If possible, site the valve in a location where any leak would be contained or routed to avoid areas sensitive to water damage.

Isolating valves **must** be installed to both inlets (supplied) and outlet, close to the Digital Mixer Valve for ease of maintenance.

Caution! Risk of product damage. The Digital Mixer Valve must be installed in a dry, ventilated area where it will not freeze.

Important Information Regarding Radio Controlled Devices

- Metal objects such as steel baths or sinks, cold water storage tanks, hot water cylinders, foil lined plaster board walls, radiators and even thick brick walls, can all dramatically reduce the radio operational range of any radio controlled product.
- Interference from other radio signals can dramatically reduce the ability of the Mira Vision User Interface / digital mixer to communicate. This may include; mobile phones, radio control boiler thermostats, wireless broadband routers, radio control toys, cordless phones, remote outdoor weather stations etc.
- **Note!** Failure to follow these guidelines can result in poor, intermittent or complete failure to communicate with the digital mixer.

Typical Suitable Installations:

1. Instantaneous Multipoint Water Heaters and Combination Boilers

Caution! Risk of product damage. Do not fit the Mira Digital Mixer - PUMPED VALVE with Instantaneous Multipoint Water Heaters or Combination Boilers.

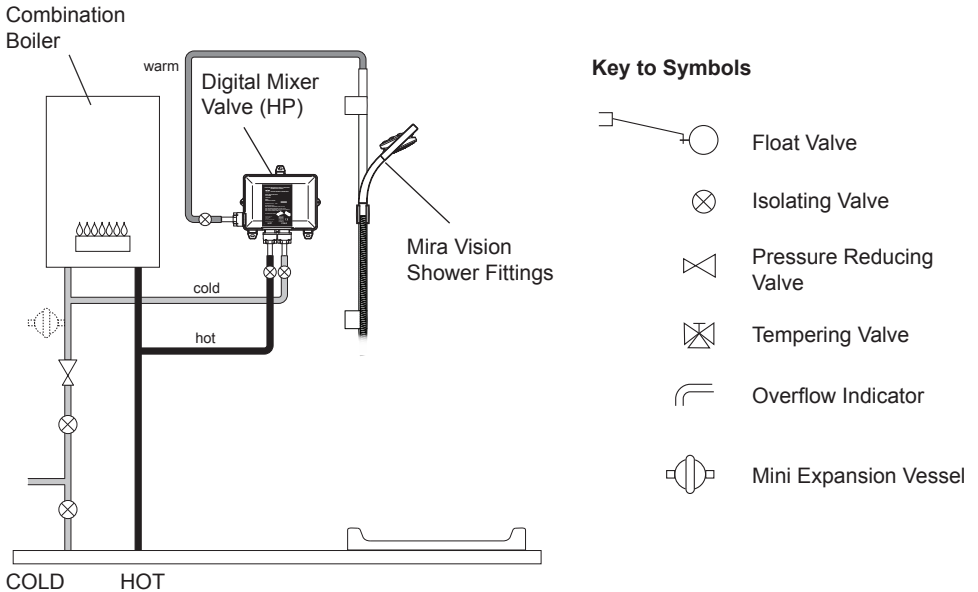

Only install the High Pressure Digital Mixer Valve with a multipoint gas water heater or combination boiler of a **fully modulating design** (i.e. where the water draw-off rate indirectly controls the gas flow rate to the burner).

An expansion vessel **must** be fitted (and regularly maintained) if any form of backflow prevention device is fitted, e.g. non-return valve or PRV. This will ensure that excess expansion or pulse pressures do not damage the product or plumbing system. The expansion vessel may already be fitted within the boiler (check with the manufacturer) and is in addition to the normally larger central heating expansion vessel.

2. Mains Pressurised Instantaneous Hot Water Shower, Heated from a Thermal Store

Caution! Risk of product damage. Do not fit the Mira Digital Mixer - PUMPED VALVE with Mains Pressurised Systems.

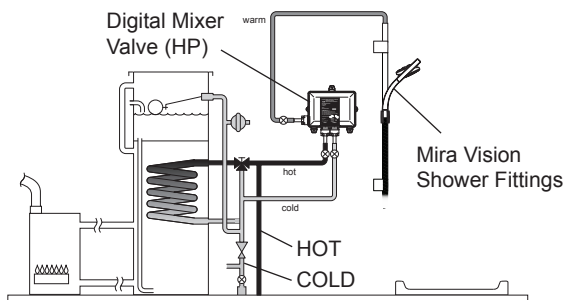

Packages of this type, fitted with a tempering valve can be used. A drop type pressure reducing valve **must** be fitted (and regularly maintained) if any form of backflow prevention device is fitted, e.g. non-return valve, PRV, then an expansion vessel should also be fitted. This will ensure that excess expansion or pulse pressures do not damage the product or the plumbing system. The expansion vessel may already be fitted externally or internally within the thermal store (check with thermal store manufacturer).

3. Gravity Fed Showers

Caution! Risk of product damage. Do not fit the Mira Digital Mixer - HIGH PRESSURE/COMBI VALVE with Gravity Fed Systems.

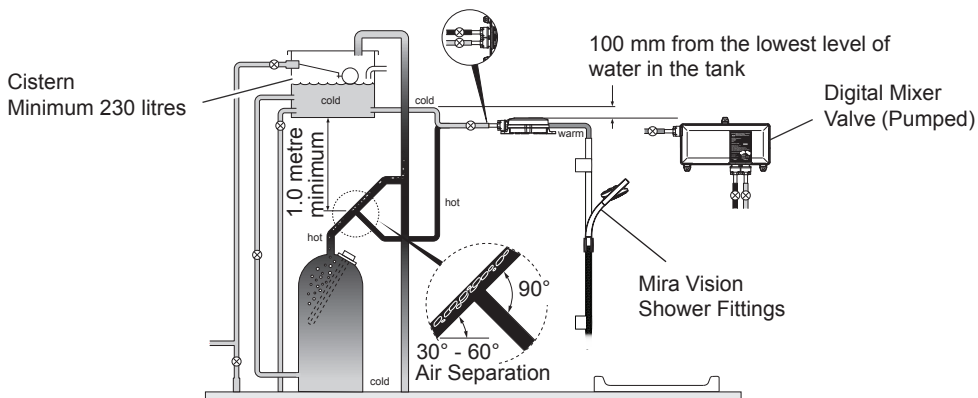

The shower control **must** be fed from a **cold water storage cistern** and a **hot water cylinder** providing nominally equal pressures. Pipework layouts and connections **must** be such that other draw-offs will not effect water supplies to the shower, shared supplies may lead to airlocking or water starvation. It is therefore best practice to have independent hot and cold supplies to the Low Pressure (pumped) Digital Mixer Valve.

Typical Examples of Poor Plumbing and Installation Practices

DO NOT:

- Install the Digital Mixer Valve where it can become frozen
- Position the Digital Mixer Valve where maintenance access is poor
- Install into a system where the cold water cistern holds less than 230 litres
- Install into a system where air locking could occur
- Install the user interface in a position where communication with the Digital Mixer Valve is poor e.g. mixer valve installed under metal bath, in front of metal cistern, more than the recommended distance away etc.
- Install the Digital Mixer Valve onto shared water supplies
- Install the Digital Mixer Valve less than 100 mm from the lowest level of water in the cistern
- Fit plastic pipework unless rigidly supported

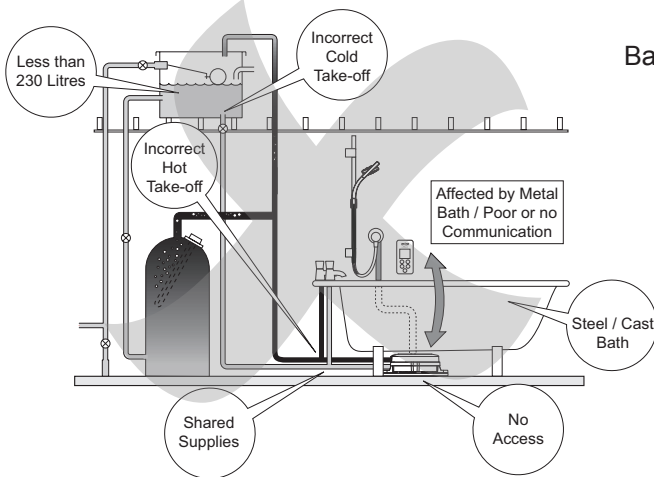

Bath Installation

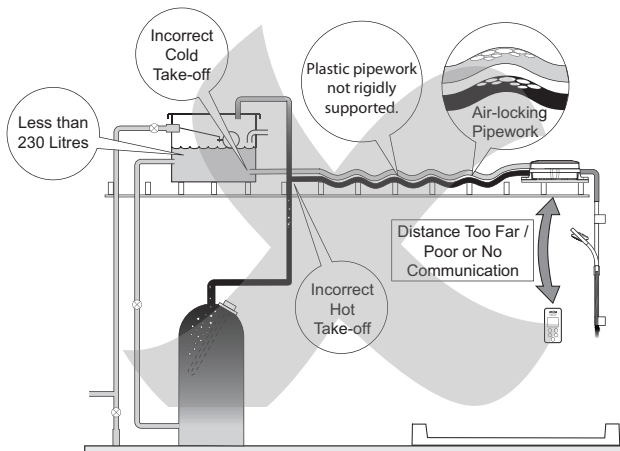

Shower Installation

Installation Schematic

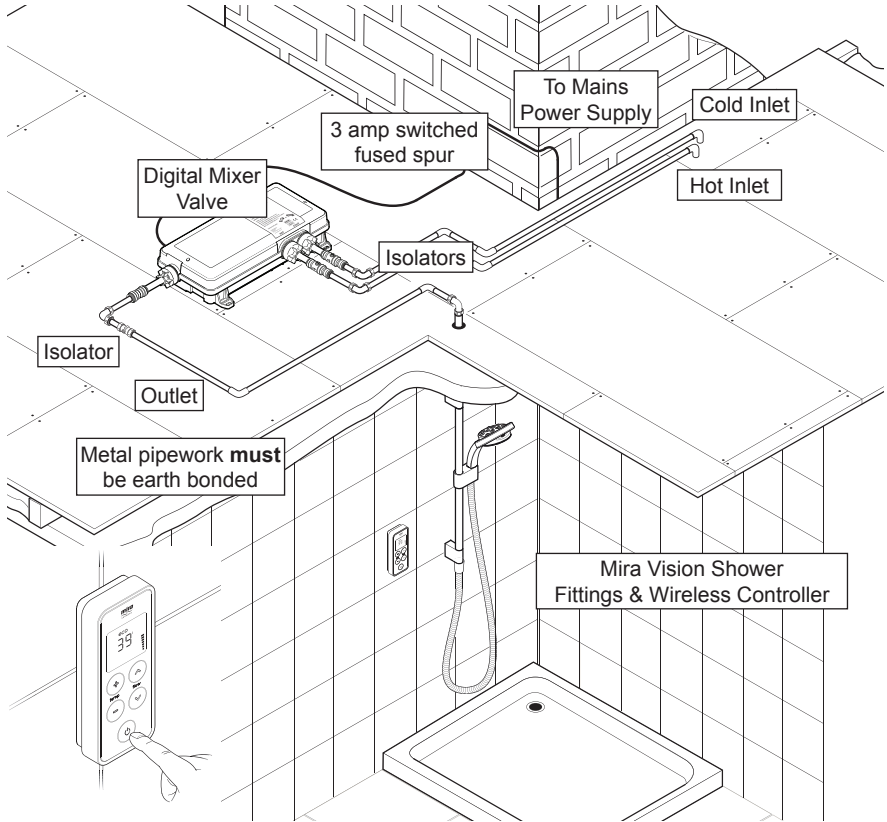

- ▶ A separate, permanently connected supply **must** be taken from the ring main to the appliance through a 3 amp double pole switched fuse spur providing a minimum 3mm contact separation gap in each pole.
- ▶ The use of supply-line or zone strainers will reduce the need to remove debris at the Digital Mixer Valve. The recommended maximum mesh aperture dimension for such strainers is 0.5 mm.
- ▶ Pipework **must** be rigidly supported to avoid any strain on the connections.
- ▶ A 30 mA Residual Current Device (RCD) **must** be included in the electrical circuit. This may be part of the consumer unit or a separate unit.

- ▶ Long inlet pipework (dead-legs) should be kept to a minimum to avoid temperature fluctuations.
- ▶ Supply pipework layout must be arranged to minimize the effect of other outlet usage upon the dynamic pressures at the Digital Mixer Valve inlets.
- ▶ To eliminate pipe debris it is essential that supply pipes are thoroughly flushed through before connection to the Digital Mixer Valve.

Valve Installation Orientation

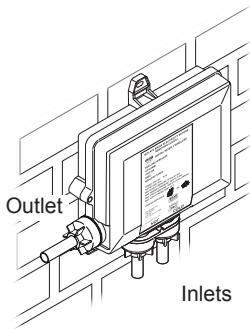

Mounting on a Vertical Surface

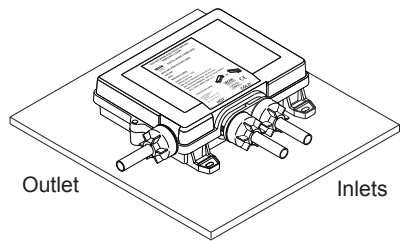

Mounting on a Horizontal Surface

- ▶ The Digital Mixer Valve (which contains the thermostatic mixing valve) may **only** be orientated in the positions shown above when mounted on a vertical or horizontal surface. Failure to do so will compromise the ability of the unit to fail-safe and deliver constant blend.
- ▶ If the power supply cable is damaged, it **must** be replaced by the manufacturer or a service engineer.
- ▶ **Warning! Turn off the electrical and water supplies before proceeding with the installation of the appliance. The electricity must be turned off at the mains and the appropriate circuit fuse electrically isolated, if applicable.**

Digital Mixer Valve

Position and Signal Test

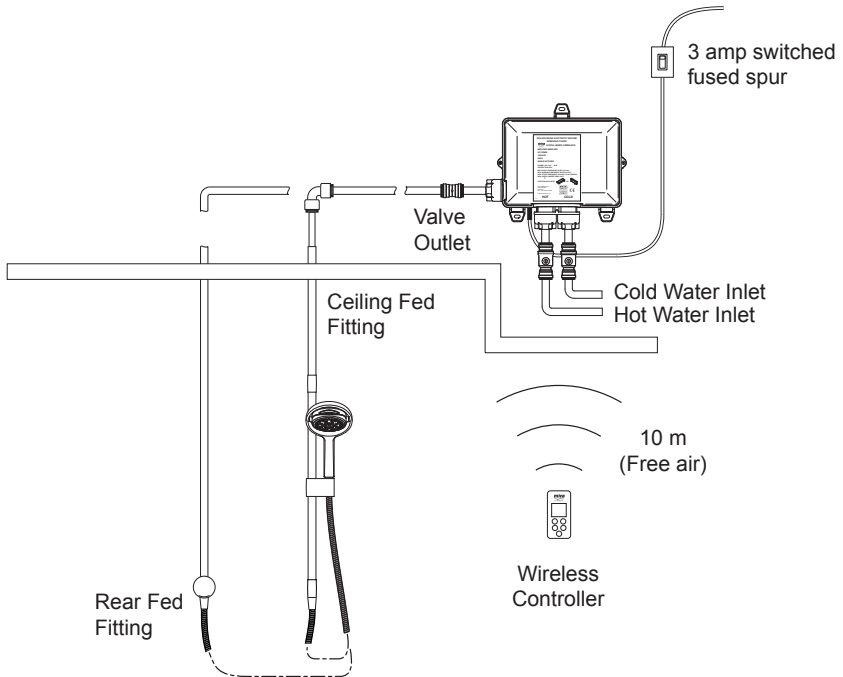

Important! When choosing a position for the Digital Mixer Valve in relation to the Wireless Controller and the Shower Fittings, consider the following points:

- ▶ The Wireless Controller can be sited up to 10 m (free air) from the Digital Mixer Valve. However, wall thicknesses and construction types may affect the remote signal strength and thereby reduce the range. The Controller range should be tested on site prior to installation to ensure shower's reliability.
Refer to Section - **INSTALLATION "Important Information Regarding Radio Controlled Devices"**.
- ▶ The length of pipework running from the Digital Mixer Valve to the Shower Fitting will have an effect on the showering temperature and the response time when changing the temperature using the Wireless Controller. The shorter the length of pipework from the Digital Mixer Valve the better the shower will respond. It is recommended that this length does not exceed 5m from the valve outlet to shower fitting.
- ▶ The ambient temperature of Digital Mixer Valve site (loft space, airing cupboard etc...) can have an effect on showering temperature. Insulate all pipework as required, particularly from the Digital Mixer Valve to the Shower Fitting. If the valve is fitted in the loft space it is recommended that any insulation is removed from underneath the valve.

- ▶ Fit 3 x AA batteries (supplied) into the wireless controller.
- ▶ Depending on the type and version of your wireless controller, the software revision number (eg. r04) may be briefly displayed, the controller will then display its default time of 10:00.
- ▶ Place Wireless Controller in approximate final position (no more than 10 m (free air) from Digital Mixer Valve) and test wireless signal by pressing the “⏻” and adjusting the temperature. If temperature display remains unchanged and “out of range” symbol is displayed, units are unable to communicate with each other.
- ▶ If test fails, reposition unit(s) and repeat test until satisfied shower will work reliably.



- ▶ **Caution! Risk of product damage. Do not run Pumped Valve (low pressure version) without a water supply for longer than 15 minutes during test.**

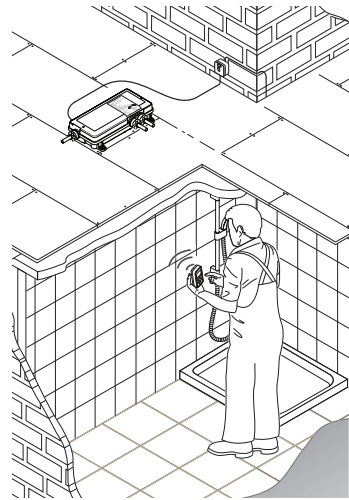

- ▶ Isolate electrical supply to Digital Mixer Valve.



- ▶ Mark the fixing holes in the required positions.

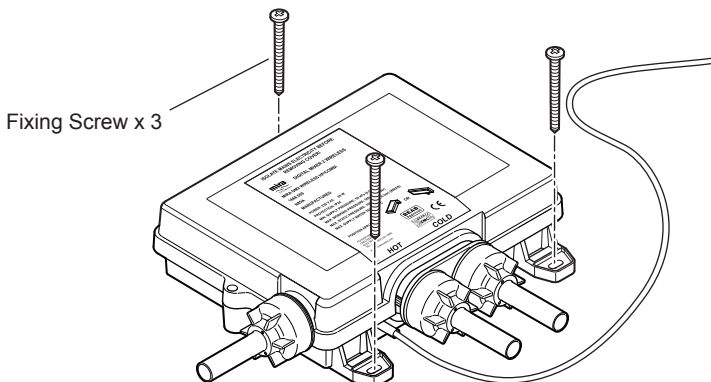

- ▶ Drill and plug the fixing holes.
- ▶ **Note!** Installers may wish to use alternative cavity fixings, when installing onto a dry lined, stud partition, shower cubicle or laminated panel wall structures. However, these methods of fixing are beyond the scope of this guide.
- ▶ Secure the Digital Mixer Valve in position with the fixing screws (supplied).

Caution! Risk of product damage. Make sure both hot and cold supply pipes are flushed thoroughly prior to connection to the Digital Mixer Valve. Any product malfunction caused by pipework debris is not covered under the guarantee.

- ▶ Connect the hot and cold water supply pipes to the Digital Mixer Valve.

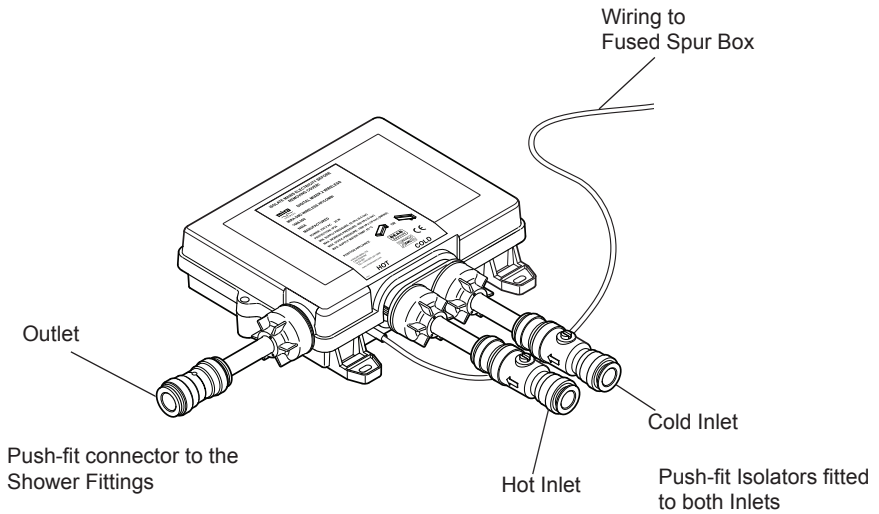

- ▶ Install the Shower Fittings and Wireless Controller (see further instructions).

Shower Fittings - Ceiling Fed

Suitable for solid, dry-lined, stud partition, shower cubicle or laminated panel walls.

The Slide Bar should be fixed to the wall at a convenient height for all the family. It should be positioned so that water sprays down the centre of the bath, or away from the opening of a shower cubicle. Water should spray away from the Wireless Controller when the Showerhead is held on the Slide Bar.

- ▶ Decide on suitable position for Slide Bar avoiding buried cables and pipes in both wall and ceiling. Make sure slide bar extension will fit through ceiling. Ceiling hole centre can be altered to avoid roof joists by using supplied spacers.

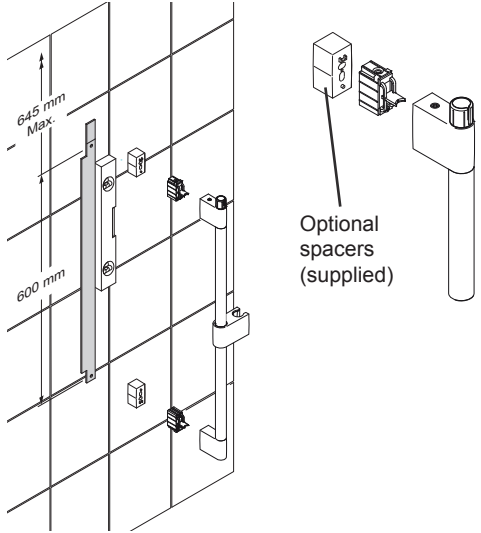

- ▶ Using template as guide, mark positions of the fixing holes for Wall Brackets (600 mm). Upper hole to be no more than 645 mm from ceiling.

Note! Use spirit level to make sure fixing holes are vertical.

- ▶ Fold long end of template and move up to ceiling. Using upper marked fixing hole as guide, mark centre for hole in ceiling.

- ▶ **Important! If supplied Slide Bar spacers are required, centre distance for hole will increase to 75 mm from wall.**

- ▶ Cut hole in ceiling 29 mm diameter.

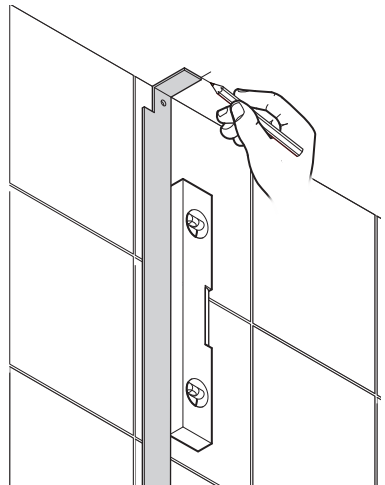

- ▶ Drill and plug Slide Bar Assembly fixing holes.

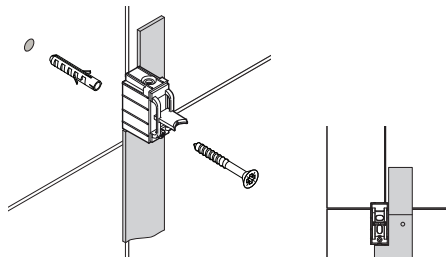

- ▶ Insert fixing screws through holes in Wall Brackets and fix to wall. Do not fully tighten. Use template to set correct distances between Wall Brackets. Fully tighten screws. Use longer fixing screws if using spacers supplied.

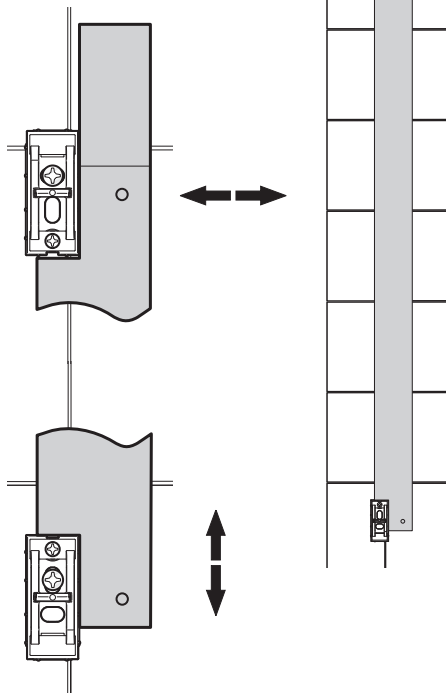

- ▶ **Note!** Slots in Wall Brackets allow for adjustment. Use one horizontal slot and one vertical slot. Make sure that holes for Slide Bar Securing Screws are positioned correctly, as shown.

- ▶ Fit ceiling plate and extension tube.

- ▶ **Note!** Extension tube may need to be shortened, use a hacksaw to shorten tube. Make sure rough end is concealed in ceiling.

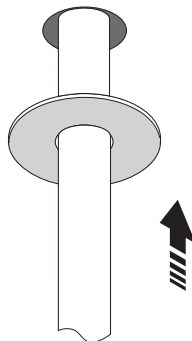

- ▶ Fit Slide Bar Assembly over Wall Brackets and secure with screws supplied. (Do not overtighten.)
- ▶ Connect ceiling extension tube.
- ▶ Feed plastic pipe up through the slide bar and extension into ceiling. Do not allow any debris to block the plastic pipe.
- ▶ **Note!** If plastic pipe requires shortening, make sure there is enough length to fit elbow (supplied) or alternative push-fit/compression fitting (not supplied).
- ▶ When shortening for use with any push-fit (e.g. John Guest) fitting, follow manufacturer's guidelines for finishing and cleaning the pipe.
- ▶ Push and twist plastic pipe end until it "**clicks**" and locks in place.
- ▶ Connect plastic pipe in ceiling to outlet pipe from valve using elbow supplied. Push all parts together fully and lock elbow onto pipes using clips supplied.
- ▶ Connect elbow to Digital Mixer Valve. Fit an isolating valve between to enable easy maintenance. (Pipe and isolating valve not supplied). Lock pipe to elbow using clip supplied. Follow manufacturer's guidelines for fitting alternative push-fit connections and flexible pipework.

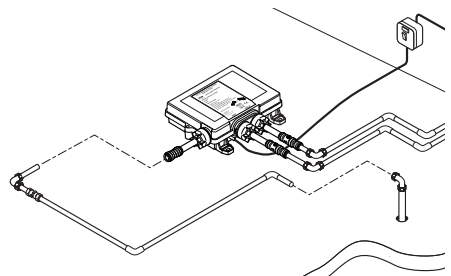
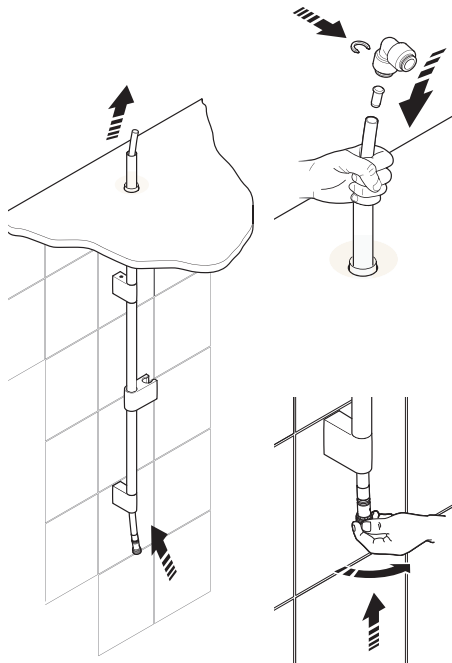
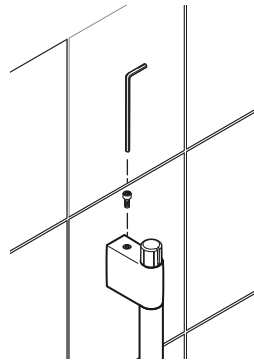

- ▶ Place first washer in end of hose, then attach to pipe end. Do not fit showerhead until after pipework has been fully flushed through. See section “**Commissioning**”.

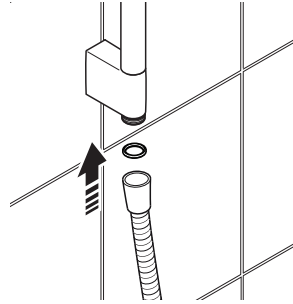

Shower Fittings - Rear Fed

Suitable for solid, dry-lined, stud partition, shower cubicle or laminated panel walls.

The Slide Bar should be fixed to the wall at a convenient height for all the family. It should be positioned so that water sprays down the centre of the bath, or away from the opening of a shower cubicle. Water should spray away from the Wireless Controller when the Showerhead is held on the Slide Bar.

- ▶ Decide on suitable position for Slide Bar avoiding buried cables and pipes in wall.
- ▶ Using template as guide, mark positions of the fixing holes for Wall Brackets (600 mm).
- ▶ **Note!** Use spirit level to make sure fixing holes are vertical.
- ▶ Drill and plug fixing holes.

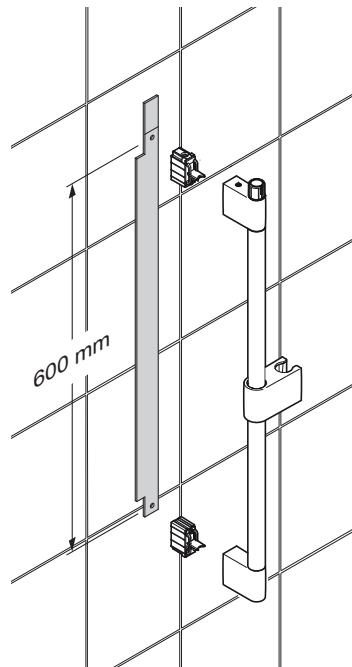

- ▶ Insert fixing screws through holes in Wall Brackets and fix to wall. Do not fully tighten at this stage. Use template to set correct distances between Wall Brackets. Fully tighten screws.

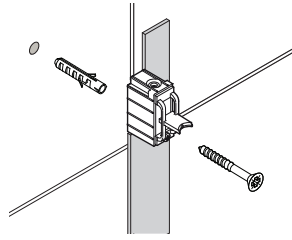

- ▶ **Note!** Slots in Wall Brackets allow for adjustment. Use one horizontal slot and one vertical slot. Make sure that holes for Slide Bar Securing Screws are positioned correctly, as shown.

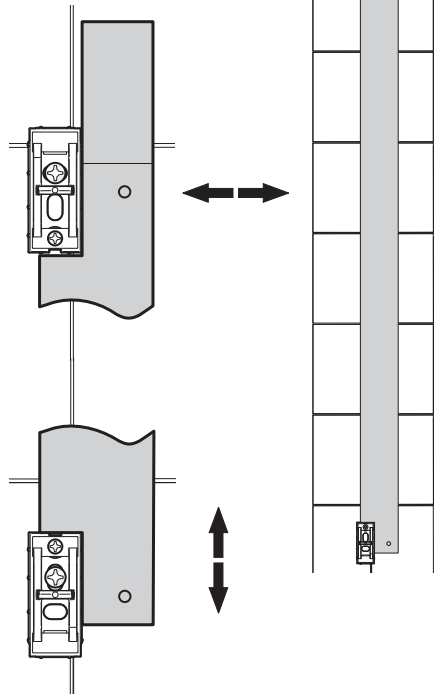

- ▶ Position Slide Bar over Wall Brackets and secure with screws. (Do not overtighten.)

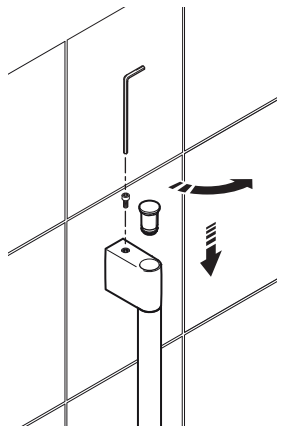

- ▶ Fit Slide Bar End Caps into top and bottom of Slide Bar Assembly. Push and twist caps until they “click” and lock in place.

- ▶ The pipe work **must** protrude through the wall between 20 - 23 mm from the finished surface of the wall. If the pipe protrudes further than 23 mm, it will prevent the backplate nut from engaging with the backplate. If necessary cut the pipe to the correct length and remove any burrs.
- ▶ Fit an isolating valve (not supplied) close to the Digital Mixer Valve for ease of maintenance.
- ▶ Loosely screw the backplate to the RAC wallplate with the two screws provided.
- ▶ Place the RAC wallplate and backplate assembly over the pipe then mark the position of the RAC wallplate and its fixing holes on the wall.
- ▶ Remove the screws and RAC wallplate from the backplate.
- ▶ Drill the two RAC wallplate fixing holes. If necessary, make a recess approximately 6 mm deep to accept the RAC wallplate. Plug the two fixing holes.
- ▶ Fix the wallplate to the wall with the two fixing screws.
- ▶ Temporarily fit the two screws to the wallplate. This will prevent the holes from being blocked with plaster and grout.
- ▶ Finish the surface of the wall as required.

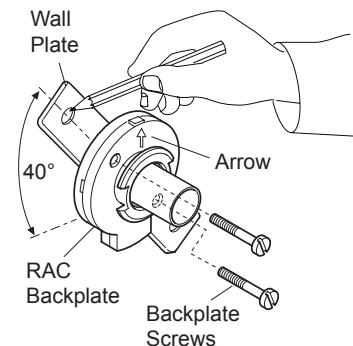
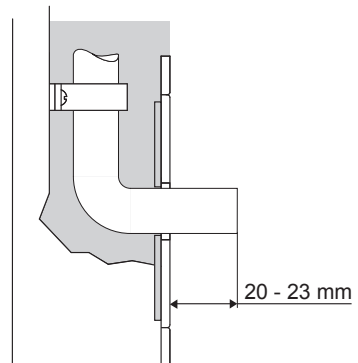
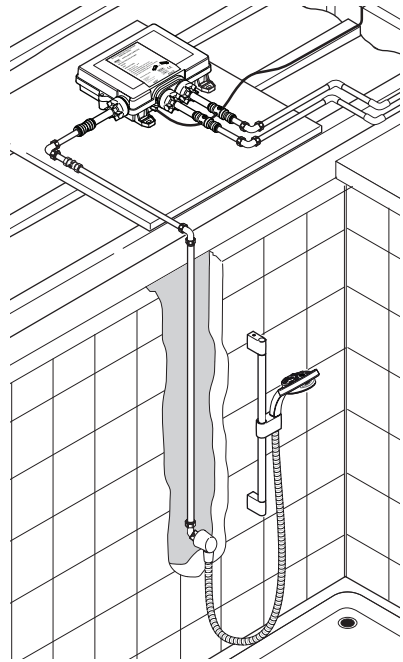

- ▶ Place the backplate over the outlet pipe with the arrow pointing vertically up and tighten the two backplate screws. Make sure that the foam seal abuts the finished wall surface.

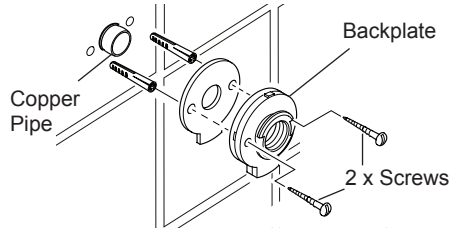

- ▶ Fit the olive and the backplate nut over the outlet pipe, do not tighten the nut fully at this point.

- ▶ Check that the 'O' seal is fitted to the outside of the backplate nut. Press the elbow onto the backplate, make sure that the clips on the elbow engage with the backplate.

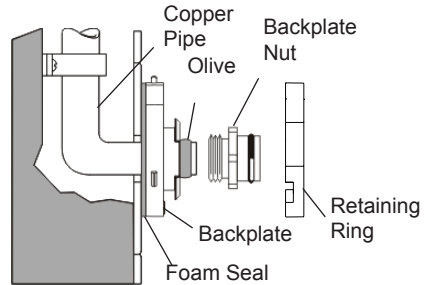

- ▶ To prevent the backplate from turning while tightening the nut, fit the retaining ring over the backplate nut making sure the slots engage with the screws on the backplate, hold the retaining ring with a wrench while tightening the backplate nut. Remove the retaining ring after use.

- ▶ Slide the retaining ring over the elbow and engage with the elbow clips. **Note!** The retaining ring must be engaged correctly to lock the elbow to the backplate, rotate the retaining ring to the position illustrated.

- ▶ Press the shroud over the elbow, make sure that it engages with the lugs on the backplate.

- ▶ Place first washer in end of hose, then attach to elbow. Do not fit showerhead until after pipework has been fully flushed through. See section "**Commissioning**".

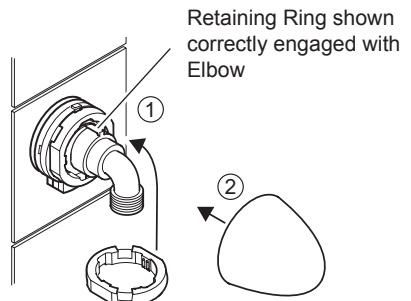
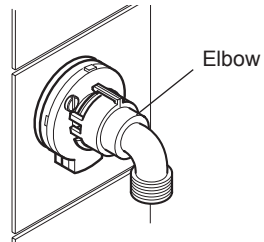
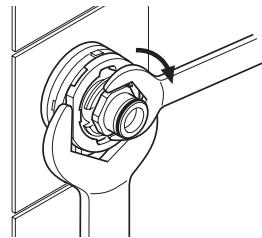

Wireless Controller

Suitable for solid, dry-lined, stud partition, shower cubicle or laminated panel walls.

The Wireless Controller should be fixed to the wall at a convenient height for all the family. It should be positioned so that water does not spray over it when the Showerhead is held on the Slide Bar.

Important! Make sure wireless signal has been tested between Wireless Controller and Digital Mixer Valve before permanently fixing to wall. (See “Digital Mixer Valve”)

- ▶ Mark position for backplate holes. Mount backplate on flat surface (e.g. Centre of tile). Drill and plug holes.

Caution! Avoid drilling through buried cables or pipes.

- ▶ Make sure surface is clean and dry. Fix backplate to finished wall surface.

- ▶ Turn controller over and remove the battery cover by loosening the 4 screws with a pozi drive screwdriver. **Note!** The screws remain attached to the battery lid.

- ▶ Only fit new batteries of same make and type. Do not use rechargeable batteries. Replace all three batteries at the same time.

- ▶ Secure battery cover

- ▶ Hook controller on top of backplate and push firmly until controller “clicks” back into place.

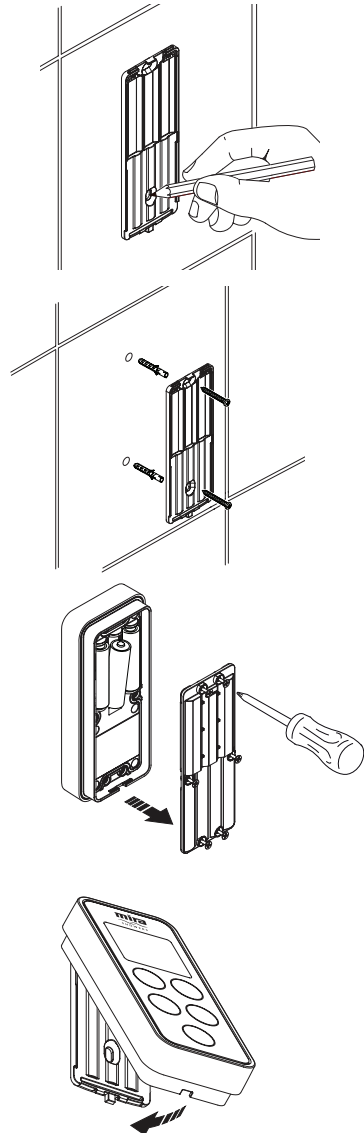

COMMISSIONING

- ▶ Turn on electrical supply to Digital Mixer Valve.
- ▶ Make sure the end of the hose is in either the bath, shower tray or other water catchment area.

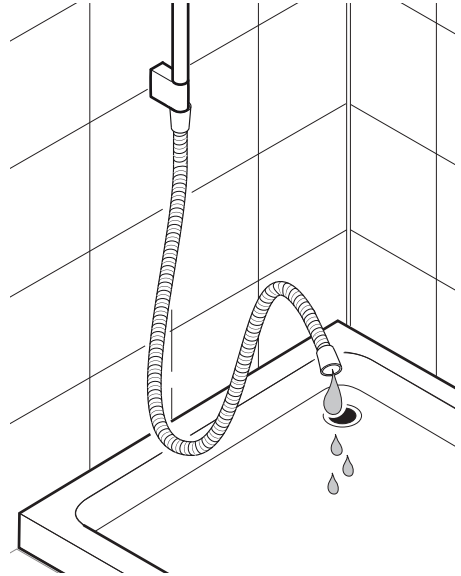

- ▶ Press “0” button and reduce temperature to full cold “CLd”. Press “^” to increase to full flow. For Low Pressure (pumped) version, let shower run in order to prime the pump. For long pipe runs, allow 3 - 4 minutes for priming.

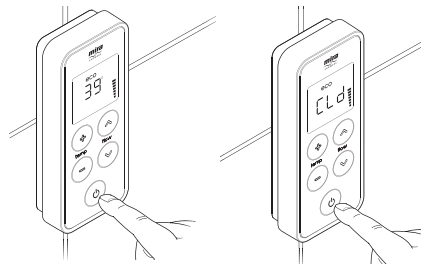

- ▶ Caution! Risk of product damage. Do not run Pumped Valve (low pressure version) without a water supply for longer than 15 minutes during priming.

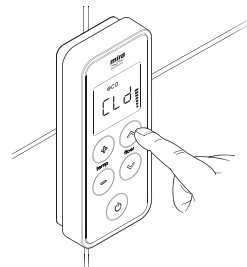

- ▶ Run cold water through (approximately 2 minutes) and check entire installation for water leaks. Press “⏻” to turn shower off. Fit the second hose washer and showerhead.
- ▶ Press “⏻” to turn shower on. Test operation of shower by increasing/decreasing both temperature and flow controls. (See User Guide for full details.)
- ▶ Test operation of showerhead spray modes. (See Showerhead User Guide for full details.)
- ▶ Refer to User Guide for further instructions on how to use the shower.
- ▶ The Wireless Controller factory default settings are as follows:

Maximum Showering Temperature	= 45°C
Eco Mode	= Off
Warm-Up Mode	= Off
Clock	= 10:00 (when batteries connected)
Clock Display	= On

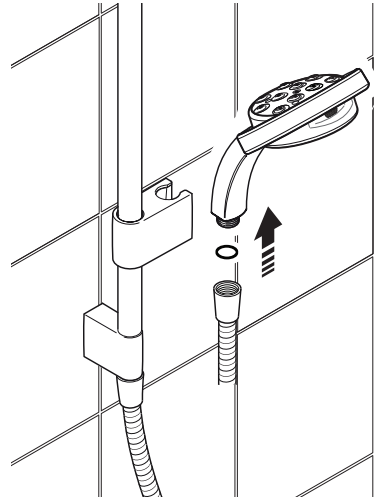

RE-REGISTERING

The wireless controller has previously been registered to the digital mixer at the factory, if communication problems are encountered, a re-registering of the wireless controller may be required.

A re-registering of the wireless controller must also be performed should the control PCB in the Digital Mixer Valve be replaced.

To re-register the wireless controller to the Digital Mixer Valve carry out the following sequence.

▶ Isolate power to the Digital Mixer Valve.

▶ Press “+” and “⏻” buttons simultaneously until “End” is displayed on the screen.

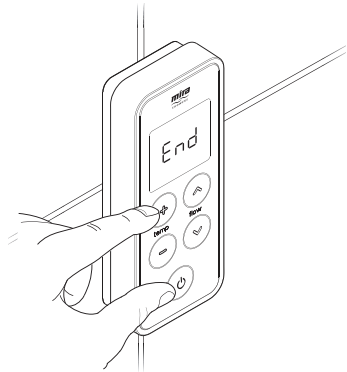

▶ Restore power to the digital mixer valve.

▶ Briefly press the “+” and “⏻” buttons, “SET” will be displayed on the screen. **Note!** if display reads “Err” press “⏻” and repeat the process.

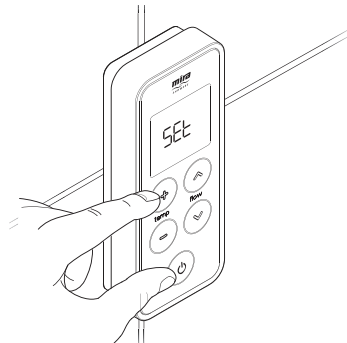

FAULT DIAGNOSIS

Read the section “**Important Safety Information**” first.

The Digital Mixer Valve is one part of an entire plumbing system. The fitting of a pump places additional requirements and some systems may require plumbing modifications to allow them to cope with higher flow rates.

Providing the Digital Mixer Valve has been correctly installed and is operated in accordance with the instructions contained in this guide, difficulties should not arise.

If any maintenance is required then it **must** be carried out by a competent tradesperson. Before replacing any parts make sure that the underlying cause of the malfunction has been resolved.

Warning! There are no user serviceable components beneath the cover of the appliance. Only a competent tradesperson should remove the cover.

Symptoms	Probable Cause	Possible Remedy
No display.	The batteries are flat or incorrectly fitted.	Check and rectify.
Out of range symbol appears on wireless controller. 	No power to Digital Mixer Valve. Signal test incomplete. Re-registering required. Digital Mixer Valve failure. Wireless Controller failure. Radio frequency interference.	Check electrical connection and supply. Repeat commissioning sequence. Refer to “ Re-Registering ”. Contact Kohler Mira Ltd. Contact Kohler Mira Ltd. Ensure all other radio transmitting devices, including mobile phones, are switched off. Repeat commissioning sequence.

Symptoms	Probable Cause	Possible Remedy
Low or no water flow.	1. Wireless Controller.	
	Out of range.	Refer to “ Out of Range ”.
	2. Digital Mixer Valve.	
	No power to Digital Mixer Valve.	Check electrical connection and supply.
	Isolators closed.	Open valves.
	Filters blocked.	Clean filters.
	Digital Mixer Valve above cold water storage cistern.	Appliance is not suitable for negative head installation. Refer to plumbing system diagrams.
Air trapped in plumbing / valve fitted in incorrect orientation.	Rearrange pipework to avoid airlock forming. Refer to “ Typical Suitable Installations ” / Valve Installation Orientation.	
3. Shower Fitting/Other.		
Blocked Showerhead.	Clean/descale showerhead.	
Water pressure is low.	Check flow rate is above stated minimum. Refer to “ Specification ”.	
Not turning on.	1. Wireless Controller.	
	Out of range.	Refer to “ Out of Range ”.
	The batteries are flat or incorrectly fitted.	Check and rectify.
	2. Digital Mixer Valve.	
	No power to Digital Mixer Valve.	Check electrical connection and supply.
	Isolators closed.	Open valves.
	Filters blocked.	Clean filters.
3. Shower Fitting/Other.		
Blocked Showerhead / hose.	Clean/descale showerhead. Change hose.	
Incorrect or fluctuating temperature.	1. Wireless Controller.	
	Controller out of range. Radio interference.	Refer to “ Out of range ”. Change controller frequency channel. Refer to User Guide - “ Control Frequency ”.
cont...		

	Warm-Up feature is being used with combi-boiler. Refer to User Guide - “Fault Diagnosis” .	Disable Warm-Up feature. Refer to User Guide - “Warm-Up” .
	2. Digital Mixer Valve.	
	Appropriate flow regulators not fitted to system using combi-boiler - (HP) .	Fit appropriate flow regulator. Refer to “Spare Parts” .
	3. Shower Fitting/Other	
	Shower temperature affected by use of adjacent hot/cold tap. Insufficiently sized pipe work to feed both Digital Mixer Valve and taps at same time.	Increase pipe sizes or separately feed shower. Refer to plumbing system diagrams under “Installation” for correct connection method.
Fluctuating or reduced flow. Refer to User Guide - “Fault Diagnosis” .	Filters blocked. Water pressure too low. Flow rate is too low. Fluctuating water temperature.	Clean filters. Check maintained pressure is within recommended range. Refer to “Specifications” . Check flow rates are within recommended range. Refer to “Specifications” . Check inlet temperatures are within recommended range. Refer to “Specifications” .
Maximum blend temperature too hot or too cold.	1. Digital Mixer Valve.	
	Incorrect maximum temperature setting.	Refer to User Guide - “Maximum Shower Water Temperature” .
Not hot enough (combi-boiler).	Appropriate flow regulators not fitted to system using combi-boiler - (HP) .	Fit appropriate flow regulator. Refer to “Spare Parts” .
Continuous flow. Shower will not shut off.	Digital Mixer Valve failure.	Change Mixer Valve (HP) or Solenoid (LP) .

Symptoms	Probable Cause	Possible Remedy
<p>Shower runs for a short time (30 - 60 seconds) then flow reduces, splutters or stops. Worst when other hot taps are in use. Less evident when shower is on full cold.</p>	<p>Air is being sucked down the vent pipe. (Gravity fed system).</p> <p>Warm up setting inadvertently selected.</p>	<p>The hot draw off pipe is positioned too high in relation to the lowest water level of the cold water cistern (100 mm min, refer to “Gravity Fed Showers” diagram. Consider increasing size of cold feed pipe to cylinder to 28 mm diameter.</p> <p>Disable Warm-Up feature. Refer to User Guide - “Warm-Up”.</p>
<p>Shower runs for a short time (3 - 5 minutes).</p>	<p>Cistern capacity insufficient (230 litres minimum required).</p> <p>Eco setting selected.</p>	<p>Increase cistern size.</p> <p>Disable Eco feature. Refer to User Guide - “Eco”.</p>
<p>Shower runs cold after 5 - 10 minutes.</p>	<p>1. Digital Mixer Valve.</p>	
	<p>Insufficient storage of hot water in cylinder - (LP).</p>	<p>Increase storage of hot water.</p>

MAINTENANCE

General

Read the section “Important Safety Information” first.

Before replacing any parts ensure that the underlying cause of the malfunction has been resolved.

If the shower is dismantled during installation or servicing then upon completion the product must be inspected to ensure there are no leaks.

Warning! There are no user serviceable components beneath the cover of the appliance. Only a competent tradesperson should remove the cover.

Cleaning

Many household cleaners contain abrasives and chemical substances, and should not be used for cleaning plated or plastic fittings. These finishes should be cleaned with a mild washing up detergent or soap solution, and then wiped dry using a soft cloth.

Checkvalve Cartridges and Filters - Removal and Installation

Hot water entering the cold supply, or vice versa, indicates that immediate attention is necessary. This is carried out by removing and cleaning, or renewing as necessary, the checkvalve cartridges.

Note! Ensure for HP Mixer Valve that flow regulator is refitted in hot supply.

- ▶ Isolate the electrical and water supplies to the Digital Mixer Valve, and open an outlet fitting to release pressure and to assist the draining of residual water.
- ▶ Unscrew plastic nuts and either withdraw pipework or remove Digital Mixer to gain access to the checkvalve cartridges and filters.
- ▶ Use flat blade screwdriver to carefully lever cartridges out.
- ▶ Remove filters and clean or renew.

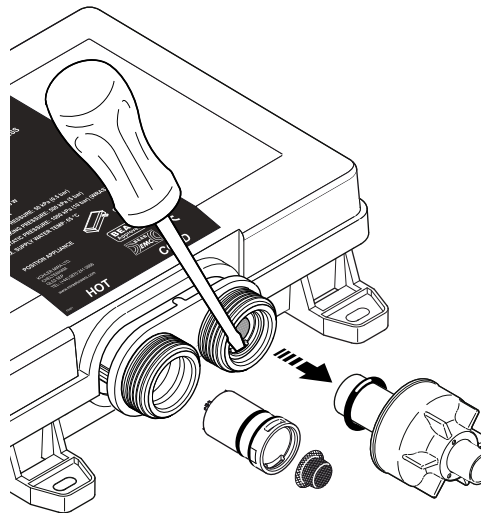

- ▶ Refit seals, pipes and plastic nuts. Plastic nuts require hand tightening only.
- ▶ Restore water supply and electrical supply. Test shower and check for leaks.

SPARE PARTS

Digital Mixer - High Pressure/Combi Valve

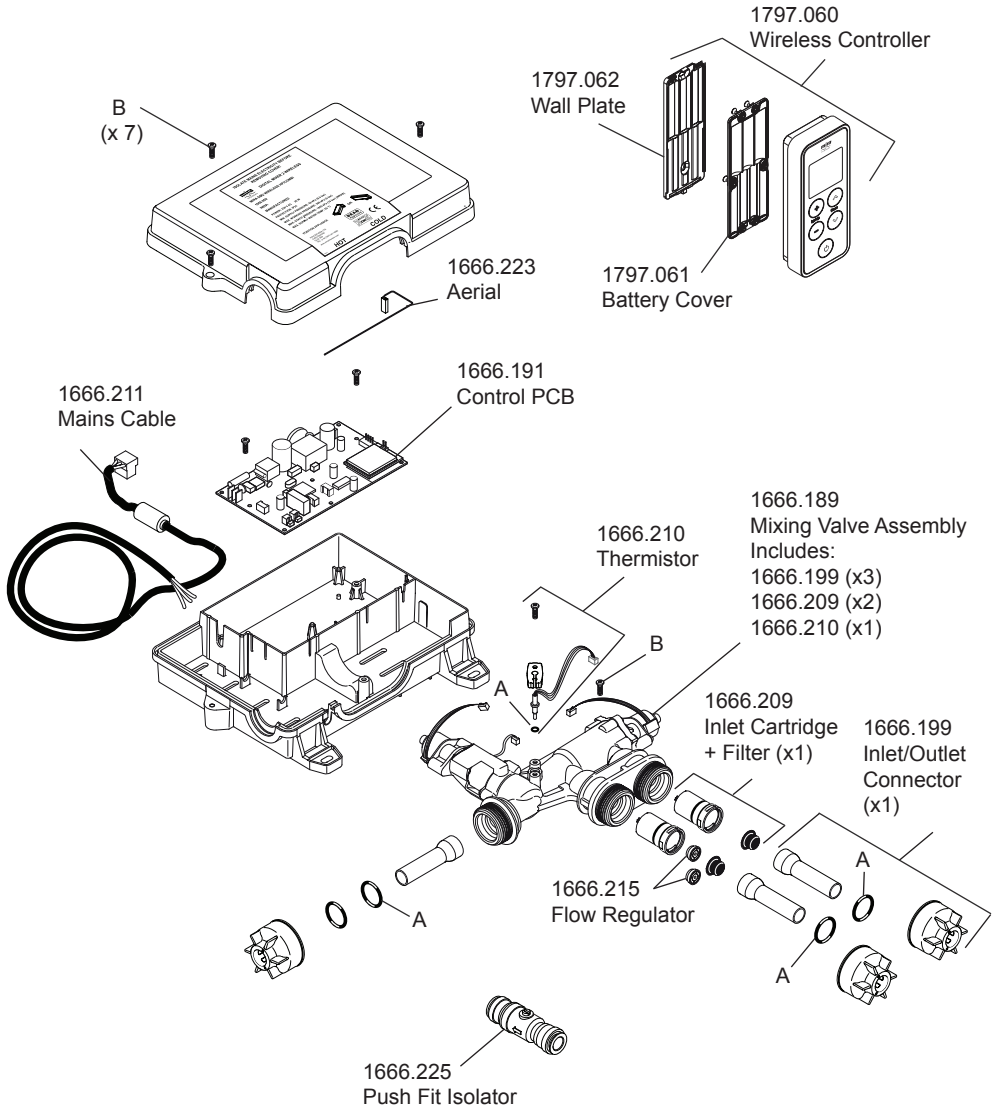

1666.212 Seal Pack - Components Identified 'A'
 1666.213 Screw Pack - Components Identified 'B'

Digital Mixer - Pumped Valve

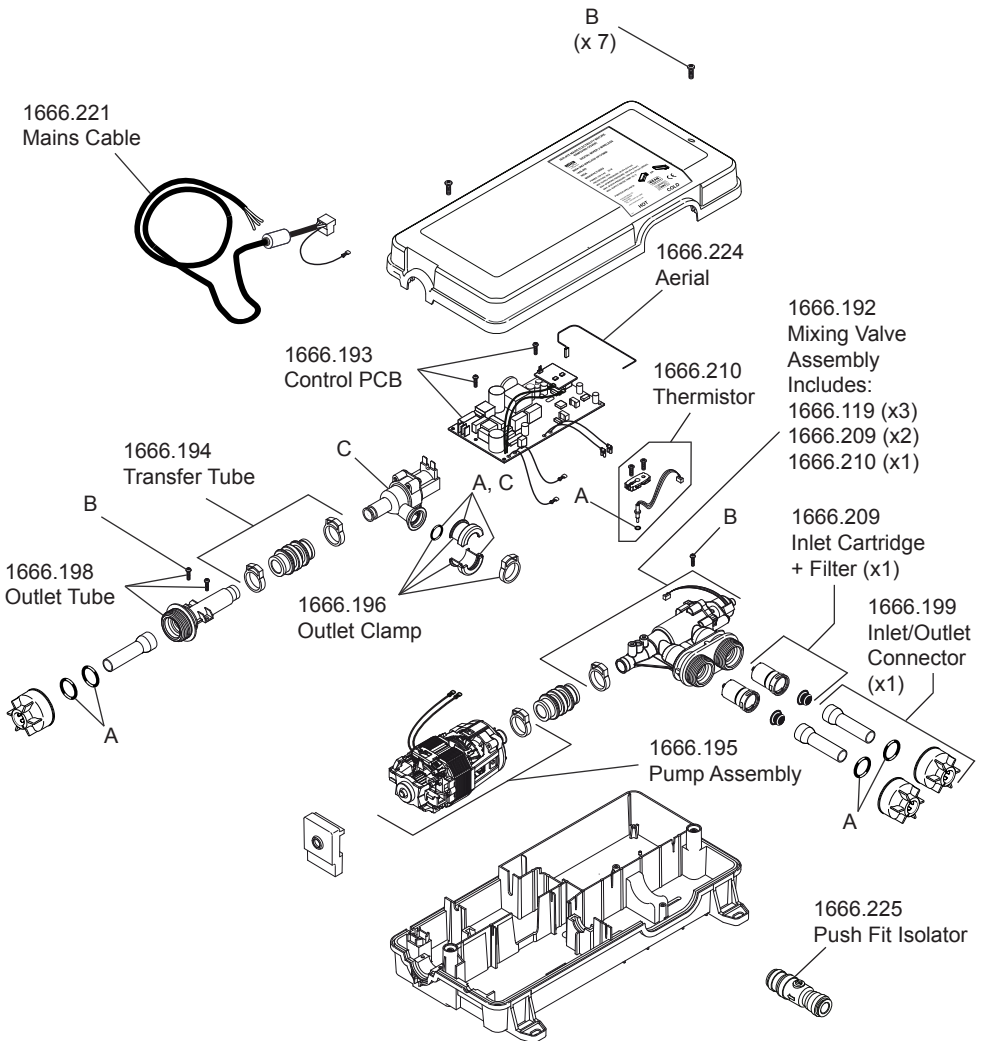

- 1666.212 Seal Pack - Components Identified 'A'
- 1666.213 Screw Pack - Components Identified 'B'
- 1666.197 Solenoid - Components Identified 'C'

Shower Fittings

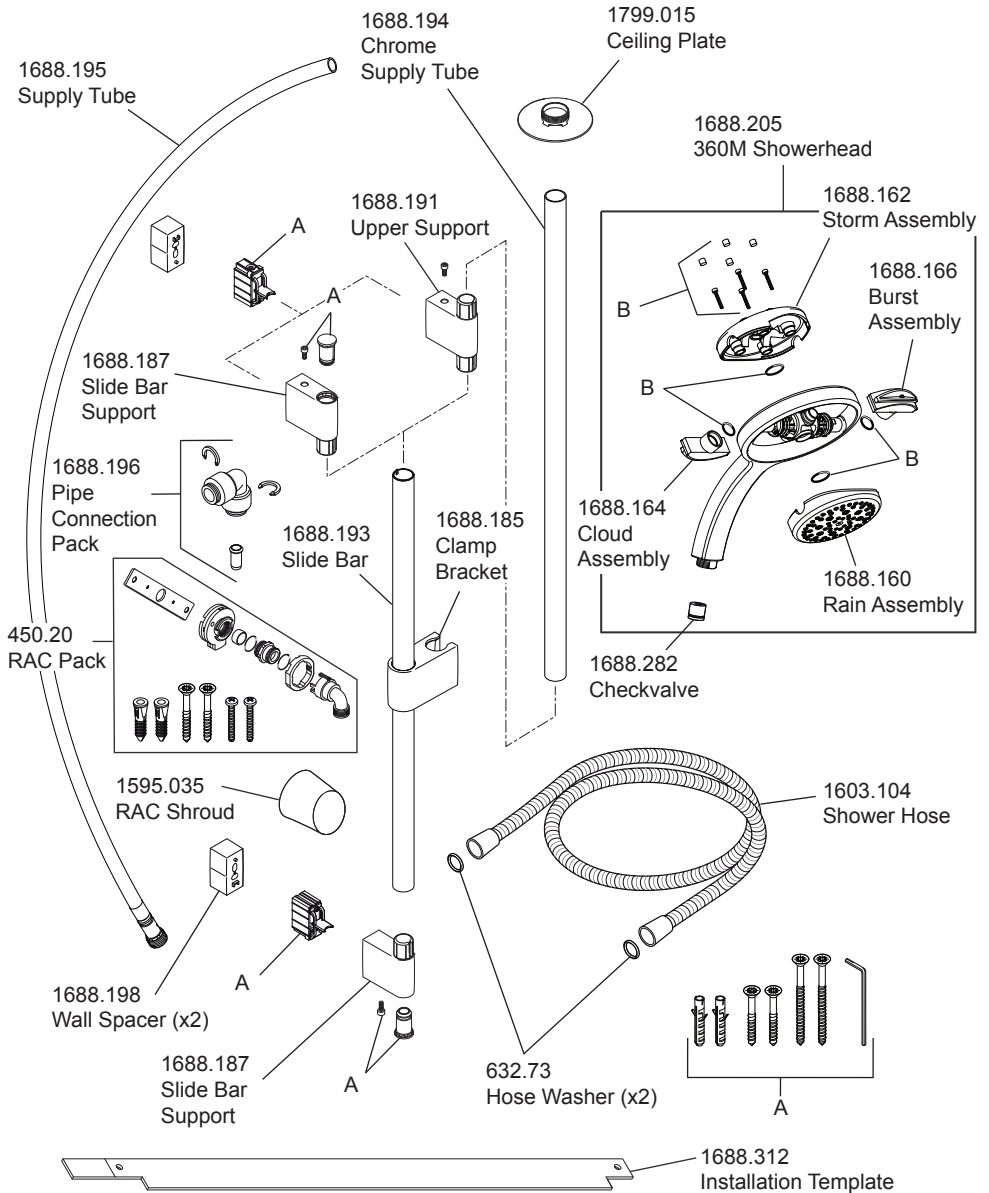

1688.184 Seal and Screw Pack - Components Identified 'B'.

1688.190 Classic Fittings Component Pack - Components identified 'A'.

ACCESSORIES

Genuine Mira accessories can be purchased direct from Customers Services (our contact details can be found on the back cover of this guide) or from approved stockists or merchants.

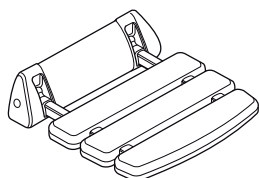

Shower Seat

White - 2.1536.128

White/Chrome - 2.1536.129

For use in or out of the showering area. Folds up when not in use. Maximum User Weight - 127 kg (20 stone) **Note!** Must be installed onto a solid wall.



Premium Shower Seat

White/Chrome - 2.1731.001

Grey/Chrome - 2.1731.002

Stylish, slim-line and robust shower seat for use in or outside of the shower area. Folds up when not in use. Maximum User Weight - 150 kg (23.5 stone) **Note!** Must be installed onto a solid wall.



Mira Standard Grab Bars

300 mm - 2.1605.070

450 mm - 2.1605.071

600 mm - 2.1605.072

Premium grade, highly polished, stainless steel grab bars.

Note! Must be installed onto a solid wall.

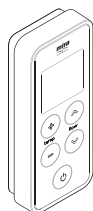

Wireless Controller

White/Chrome - 1.1797.005

Wireless Controller available as a complete accessory if more than one controller is required. Comes complete with batteries and wall fixings. Test before fixing to wall. Install and test in accordance with the instructions contained within this guide.

DISPOSAL AND RECYCLING

End of Product Life

When this appliance has reached the end of its serviceable life, it should be disposed of in a safe manner, in accordance with current local authority recycling, or waste disposal policy.

Batteries

Spent batteries should not be disposed of with normal household waste. Contact your local authority for information on waste disposal and recycling.



This symbol on the product or its packaging indicates that this product should not be disposed of with your other household waste. Instead, it is your responsibility to dispose of your waste equipment by handing it over to a designated collection point for the recycling of waste electrical and electronic equipment. The separate collection and recycling of your waste equipment at the time of disposal will help to conserve natural resources and ensure that it is recycled in a manner that protects human health and the environment. For more information about where you can drop off your waste equipment for recycling, please contact your local council office, your household waste disposal service or the shop where you purchased the product.

NOTES

NOTES

CUSTOMER SERVICE

Guarantee

Your product has the benefit of our manufacturer's guarantee which starts from the date of purchase.

To activate this guarantee, please return your completed registration card, visit our website or free phone 0800 0731248 within 30 days of purchase (UK only).

Within the guarantee period we will resolve defects in materials or workmanship, free of charge, by repairing or replacing parts or product as we may choose.

This guarantee is in addition to your statutory rights and is subject to the following conditions:

- The guarantee applies solely to the original installation under normal use and to the original purchaser only. The product must be installed and maintained in accordance with the instructions given in this user guide.
- Servicing must only be undertaken by us or our appointed representative. **Note!** if a service visit is required the product must be fully installed and connected to services.
- Repair under this guarantee does not extend the original expiry date. The guarantee on any replacement parts or product ends at the original expiry date.
- For shower fittings or consumable items we reserve the right to supply replacement parts only.

The guarantee does not cover:

- Call out charges for non product faults (such as damage or performance issues arising from incorrect installation, improper use, inappropriate cleaning, lack of maintenance, build up of limescale, frost damage, corrosion, system debris or blocked filters) or where no fault has been found with the product.
- Water or electrical supply, waste and isolation issues.
- Compensation for loss of use of the product or consequential loss of any kind.
- Damage or defects caused if the product is repaired or modified by persons not authorised by us or our appointed representative.
- Routine maintenance or replacement parts to comply with the requirements of the TMV 2 or TMV 3 healthcare schemes.
- Accidental or wilful damage.
- Products purchased ex-showroom display.

What to do if something goes wrong

If your product does not work correctly refer to this manual for fault diagnosis and check that it is installed and commissioned in accordance with our instructions. If this does not resolve the issue, contact us for help and advice.

Extended Guarantees

A selection of protection plans are available that enable you to cover repair bills (excludes Eire). Ring 01922 471763 for more details.



Helpdesk Service - Ring our Customer Services Team for product advice, to purchase spare parts or accessories or to set up service visit. You can contact us via phone or e-mail, details below. Please provide your model name, power rating (if applicable) and date of purchase.



Mira Showers Website (www.mirashowers.co.uk)

Visit our website to register your guarantee, download user guides, diagnose faults, purchase our full range of accessories and popular spares, or request a service visit.



Spares and Accessories - We hold the largest stocks of genuine Mira spares and accessories. Contact us for a price or visit our website to purchase items from our accessory range and popular spares.



Service/Repairs - No one knows our products better than our nationwide team of Service Technicians. We can carry out service or repair work to your product both during and after the guarantee period. Ask about our fixed price service repairs.

To Contact Us: UK



0844 571 5000



Fax: 01242 282595



E-mail: Visit www.mirashowers.co.uk/contactus



Mira Customer Services Dept, Cromwell Road, Cheltenham, Gloucestershire, GL52 5EP

To Contact Us: Eire Only



01 531 9337



E-mail: CustomerServiceEire@mirashowers.com

Mira is a registered trade mark of Kohler Mira Limited.

The company reserves the right to alter product specifications without notice.



mira
SHOWERS