

**TRITON**

**ASPIRA**  
**concentric exposed**  
**thermostatic mini mixer shower**

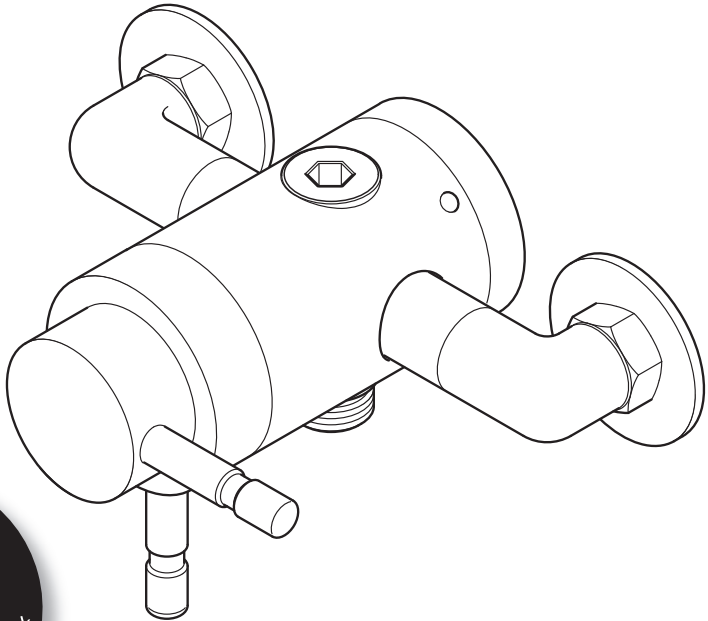

**Installation and  
operating instructions**

INSTALLERS PLEASE NOTE THESE INSTRUCTIONS ARE TO BE LEFT WITH THE USER

<b>CONTENTS</b>	<b>Page</b>
MAIN COMPONENTS.....	1
INTRODUCTION.....	2
SITE REQUIREMENTS .....	2
SAFETY WARNINGS .....	2
PLUMBING REQUIREMENTS .....	3
WATER SYSTEM REQUIREMENTS.....	3
TYPICAL DOMESTIC INSTALLATIONS.....	4 - 6
INSTALLATION.....	7
FITTING THE MIXER.....	8
FLOW REGULATION.....	9
FITTING THE FIXED ARM & SHOWERHEAD.....	9 -10
ANTI-SCALD PROTECTION .....	10
LEAK TESTING .....	10
COMMISSIONING.....	10
ADJUSTING THE MAXIMUM TEMPERATURE SETTING .....	11
OPERATING THE SHOWER .....	12
APPROVALS .....	13
FLOW CHART .....	13
DIMENSIONS .....	14
SPARE PARTS.....	15
MAINTENANCE .....	16
Cleaning the filters.....	16
FAULT FINDING.....	17 - 18
Guarantee, service policy, etc.....	rear cover

To check the product suitability for commercial and multiple installations, please contact Triton's specification advisory service before installation.

Telephone: 0844 980 0730

Facsimile: 0844 980 0744

E mail: [technical@tritonshowers.co.uk](mailto:technical@tritonshowers.co.uk)

## MAIN COMPONENTS

Fig.1

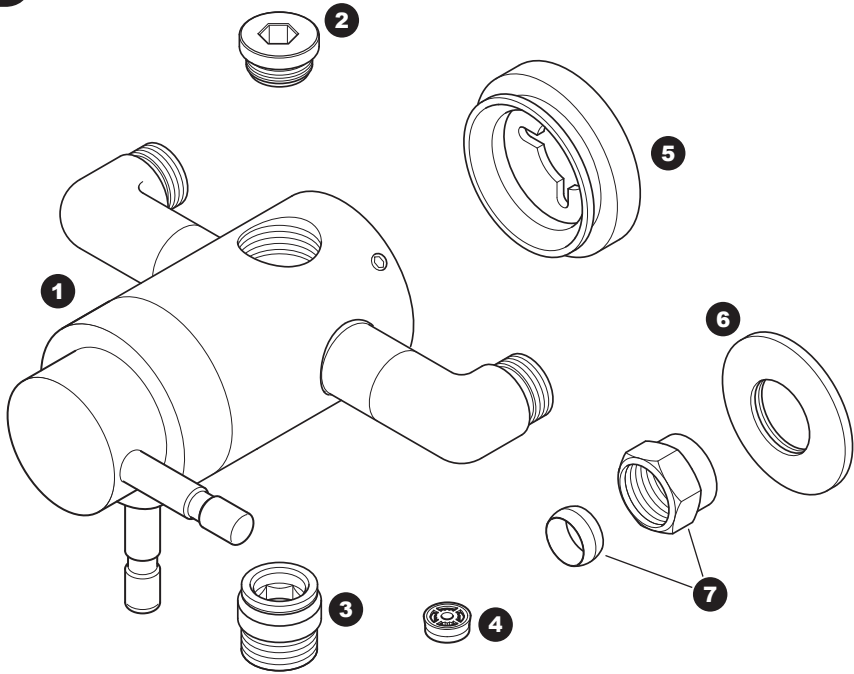

### Ref. Description

- |                      |                           |
|----------------------|---------------------------|
| 1. Mixer shower body | 5. Mounting plate         |
| 2. Blanking plug     | 6. Wall trim X2           |
| 3. Outlet adapter    | 7. Inlet nut and Olive X2 |
| 4. Flow regulator    |                           |

All dimensions listed in this fitting book regarding the product and installation are approximate.

\*All kits are for illustration purposes only and are not supplied unless otherwise stated.

### INTRODUCTION

This book contains all the necessary fitting and operating instructions for your Triton mixer shower. Please read them carefully and read through the whole of this book before beginning your installation.

The shower installation must be carried out by a suitably competent person and in sequence of this instruction book.

Care taken during the installation will give a long and trouble free life from your mixer shower.

### SITE REQUIREMENTS

The installation must be in accordance with water supply (water fittings) regulation 1999 and/or local Bylaws.

#### Water pressure requirements

*Running water pressure:*

Low pressure	- 0.1 bar min. 1.0 bar max.
High pressure	- 0.5 bar min. 5.0 bar max.

*Maximum static water pressure:*

Low & High pressure	- 10 bar
---------------------	----------

This mixer shower is designed for use with traditional low pressure 'gravity' water systems, using a cold water cistern and hot water cylinder as well as for the higher pressure systems found in the UK up to a maximum of 5 bar running pressure.

For effective operation of the internal seals, the maximum static pressure must not be exceeded.

#### Pressure reducing valve

On sites where the running pressure is above 5 bar, the use of a suitably sized pressure reducing valve fitted in the cold mains supply pipe work can provide nominally equal pressures at the mixer shower.

Replacement parts can be ordered from Triton Customer Service. See 'spare parts' for details and part numbers.

#### Water minimum flow rate

For best performance within the specified running pressure range a minimum flow of 8 litres per minute should be available to both inlets.

#### Water temperature requirements

Maximum hot water temperature: = 80°C

Recommended maximum: = 65°C

Minimum hot water temperature: = 55°C

Maximum cold water temperature: = 25°C

**NOTE:** Valves operating outside these conditions cannot be guaranteed by the Scheme to operate as Type 2 valves.

**The mixer shower MUST NOT be subjected to water temperatures above 80°C.**

BS 6700 recommends that the temperature of stored water should never exceed 65°C.

A stored water temperature of 60°C is considered sufficient to meet all normal requirements and will minimise the effects of scale in hard water areas.

#### Water temperature adjustment and thermal safety

The mixed water temperature can be adjusted from cold through to a top limit which must be preset during installation with full anti-scald protection throughout the range (35°C to 40°C) providing the hot water temperature at the inlet remains 10°C above the outlet temperature.

Should there be a loss of flow to either incoming supply then- water from the shower will stop or be reduced until both supplies are restored.

### SAFETY WARNINGS

- DO NOT** choose a position where the shower could become frozen.
- DO NOT** connect this mixer shower to any form of tap or fitting not recommended by the manufacturer.
- DO NOT** allow the inlet pressure or flow rates to operate outside the guidelines laid out in 'site requirements'.
- DO NOT** connect the mixer shower to a gravity hot supply and a mains cold supply (or vice versa).

## PLUMBING REQUIREMENTS

**DO NOT** use jointing compounds on any pipe fittings for the installation,

**DO NOT** solder fittings near the mixer unit as heat can transfer along the pipework and damage the mixer valve.

### IMPORTANT:

- The layout and sizing of pipework **MUST** be such that nominally equal inlet supply pressures are achieved and the effects of other draw-offs are minimised.
- The pipe-work should be installed such that other taps and appliances being operated elsewhere on the premises do not significantly affect the flow
- When connecting pipe-work avoid using tight 90° elbows; swept or formed bends will give the best performance.
- The hot water pipe entry must be made to the left-hand side inlet, marked HOT, 'H' or with a red/orange label.
- Suitable isolating valves (complying with Water Regulations and Bylaws) must be fitted on the hot and cold water supplies to the shower as an independent means of isolating the water supplies should maintenance or servicing be necessary.
- It is preferable to flush the pipe-work to clear the system of debris and check for leaks before connecting to the mixer.
- The mixer inlets contain removable filters that may become blocked if debris is not flushed through before fitting.

### **(Commercial applications)**

- Triton recommends for all commercial applications that, easily accessible, in-line filters are used to aid maintenance.

## Hard water areas

- a. If it is intended to operate the shower in areas of hard water (above 200-ppm temporary hardness), a scale inhibitor may have to be fitted. For advice on the Triton scale inhibitor, please contact Customer Service.
- b. For best performance the showerhead **MUST** be regularly cleaned to remove scale and debris.

## WATER SYSTEM REQUIREMENTS

This mixer shower is suitable for: -

- Gravity water systems
- Pumped gravity systems.
- Fully modulating type combination boilers
- Multi-point hot water heaters.
- Thermal storage,
- Unvented systems

When installing this mixer with a Combination or multi-point boiler, it may be necessary to install flow regulation.

Check that the appliance is capable of delivering hot water at a minimum switch-on flow rate of 3 litres per minute. At flow rates between 3 and 8 litres per minute, the appliance must be capable of raising the water temperature to 52°C (minimum).

Water temperature at the inlet of the mixer valve must remain relatively constant when flow rate adjustments are made (refer to the appliance-operating manual to confirm compatibility with this mixer shower).

Where thermal store systems and instantaneous gas water heaters are used, if excessive draw-off take place the appliance may not be able to maintain an adequate output temperature. This could result in the shower temperature becoming noticeably cooler.

Flow regulators can be fitted with high-pressure water systems to reduce flow rate and assist economy.

The hot supply temperature **MUST** remain a minimum of 10°C hotter than the required blend temperature for optimum performance.

**\*Fig.2**

*\*(diagrammatic view – not to scale)*

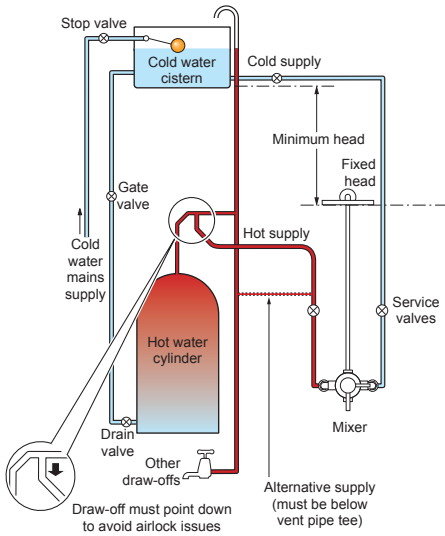

**TYPICAL DOMESTIC INSTALLATIONS**

**Domestic gravity fed systems (fig.2)**

The shower control **MUST** be fed from a cold water cistern and hot water cylinder providing nominally equal pressures. There must be a minimum of one metre head of water. The minimum head distance is measured from the base of the cold water cistern to top of the showerhead.

If valves are gravity fed then supply pressure should be verified to ensure conditions of use are appropriate for the valve.

**Pumped gravity fed systems (fig.3)**

The shower control **MUST** be fed from a cold water cistern and hot water cylinder providing nominally equal pressures.

The mixer unit may be used with a gravity fed system with a pump to boost pressures as shown; please refer to the pump installation guide to establish the minimum head requirements for automatic operation of the pump.

**\*Fig.3**

*\*(diagrammatic view – not to scale)*

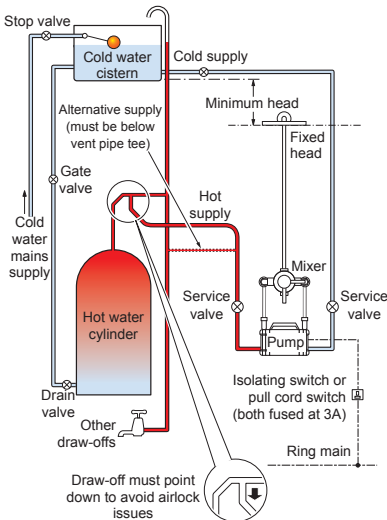

*\*(kits are for illustration purposes only)*

**Instantaneous gas-heated systems, e.g. combination boilers (fig.4)**

The shower control MUST be installed with a multi-point gas water heater or combination boiler of a fully modulating design (i.e. to maintain relatively stable hot water temperatures).

A drop tight pressure reducing valve MUST be fitted if the supply pressures exceed 5 bar running.

An expansion vessel **MAY** be fitted, and regularly maintained, to prevent the shower mixer being damaged by excess pressures. This may already be installed within the boiler (check with manufacturer) and is in addition to the normally larger central heating expansion vessel.

**Unvented mains pressure systems (fig.5)**

The shower control can be installed with an unvented, stored hot water cylinder.

For systems with no cold water take off after the appliance reducing valve, it will be necessary to fit an additional drop tight pressure-reducing valve when the mains pressure is over 5 bar. The drop tight pressure reducing valve must be set at the same value as the unvented package pressure reducing valve.

Note: An additional expansion vessel may be required if a second pressure-reducing valve is installed. This does not apply to packages with a cold take off after the pressure-reducing valve to the cylinder.

**\*Fig.4**

*\*(diagrammatic view – not to scale)*

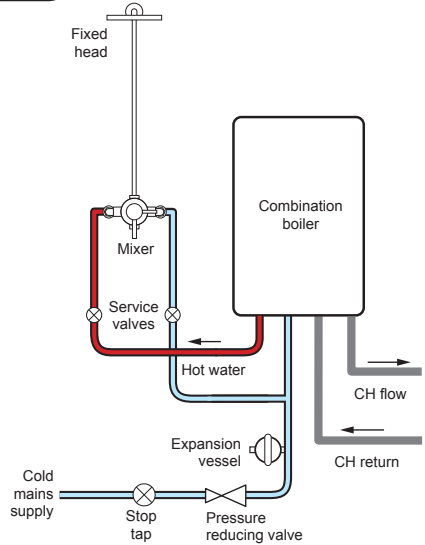

**\*Fig.5**

*\*(diagrammatic view – not to scale)*

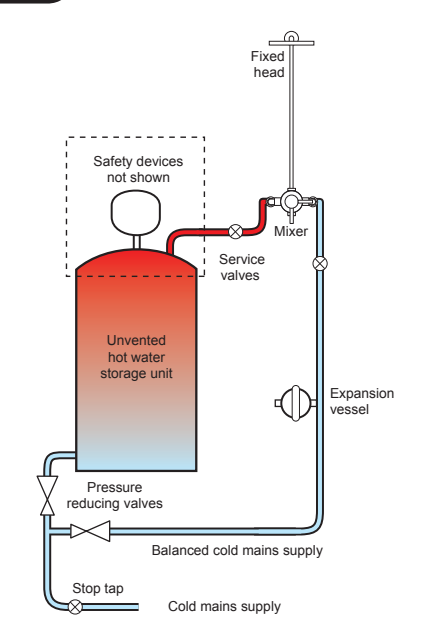

*\*(kits are for illustration purposes only)*

## Concentric exposed thermostatic mixer shower

**\*Fig.6**

*\*(diagrammatic view – not to scale)*

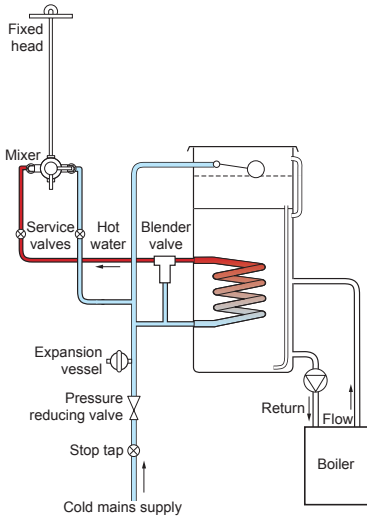

### **Mains pressurised thermal store systems (fig.6)**

Packages of this type, fitted with a tempering valve (blender valve) can be used. A drop tight pressure reducing valve MUST be fitted if the supply pressures exceed 5 bar running.

An expansion vessel MUST be fitted, and regularly maintained, to ensure, the unit, is not damaged by excess pressures. This may already be installed externally or internally within the thermal store (check with thermal store manufacturer).

*\*(kits are for illustration purposes only)*



## INSTALLATION

### Preparing the mixer valve

Check the contents to make sure all parts are present.

Before starting the mixer installation, make sure all the openings on the valve are carefully covered to stop ingress of any debris, etc. while routing the supply pipework.

The shower valve is suitable for exposed installation onto solid wall, a stud partition wall, dry lined wall or fixing to a laminate cubicle or panel.

### Siting of the shower and accessories

Refer to **(fig.7)** for correct siting of the shower.

The mixer valve should be positioned, as detailed, with all controls within comfortable reached of the user.

The accessories (showerhead, riser rail) can be positioned above or to either side of the shower, refer to **(fig.7)**.

**The valve must be installed in a position that allows for easy access for future maintenance and commissioning.**

### Supply pipe work

Complete the pipework to the shower area having decided on the position of the shower and direction of pipe entry (for example rising, falling or rear entry)

The hot and cold water pipes should not be permanently attached to the wall within one metre of the valve, before installation is complete, to allow for final adjustment of the valve position.

### Rear entry supplies

Using a spirit level, mark the route of incoming hot and cold water supply pipes at a distance of 150mm (approximately) between centres **(fig.8)**.

**\*Fig.7**

*\*(diagrammatic view – not to scale)*

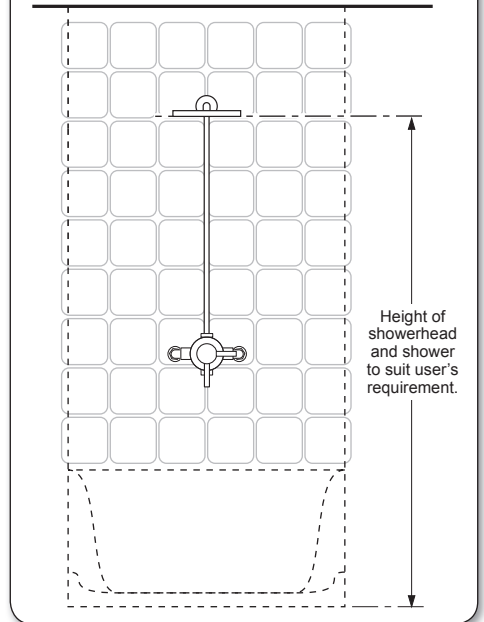

**Fig.8**

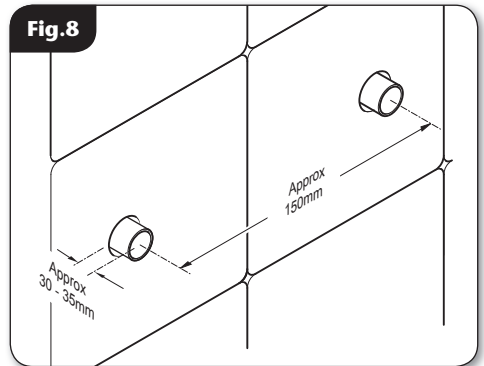

*\*(kits are for illustration purposes only)*

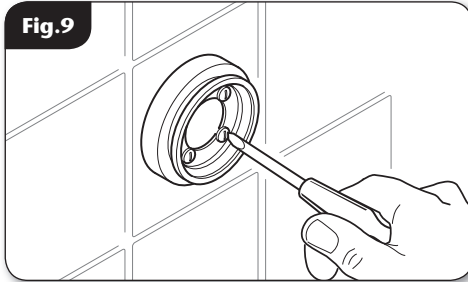

Fig.9

## FITTING THE MIXER

Mark the position of the four locating screws for the mounting plate, although if installing to a solid brick wall using two diagonal holes will usually be enough.

Drill and plug the wall.

(An appropriate drill bit should be used. If the wall is brick, plasterboard or a soft building block, appropriate wall plugs and screws should be fitted).

Fit the mounting plate onto the wall (**fig.9**).

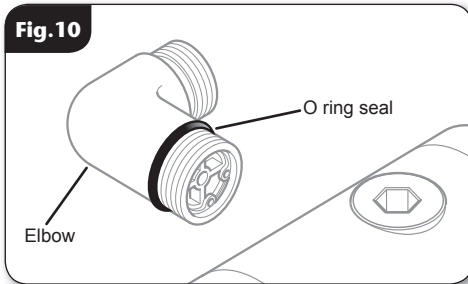

Fig.10

The inlet elbows allow for either rising, falling or rear entry hot and cold water supplies. The elbows have 'O' ring seals (**fig.10**) to the body and do not require PTFE tape or other means of sealing - (see page 15 **Fig.A** for elbow disassembly and filter cleaning).

See (**fig.11**) for how to install the 150mm elbows. A suitable tool should be used to tighten the adaptors into the body - (a 20 pence coin for example).

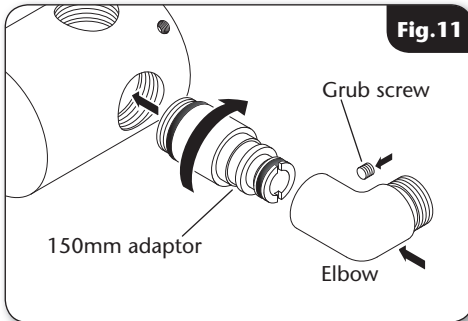

Fig.11

**Note: Do not over tighten the adaptors and care should be taken not to create sharp edges on the tightening surfaces.**

### IMPORTANT:

**Make sure that all the supply pipework has been flushed through before fitting the mixer.**

Fit the trim onto the inlet water pipes followed by the nut and olive (**fig.12**).

Connect the hot water supply to the inlet marked **HOT**, 'H' or red/orange label and connect the cold water supply to the inlet marked **COLD**, 'C' or blue label (**fig.12**).

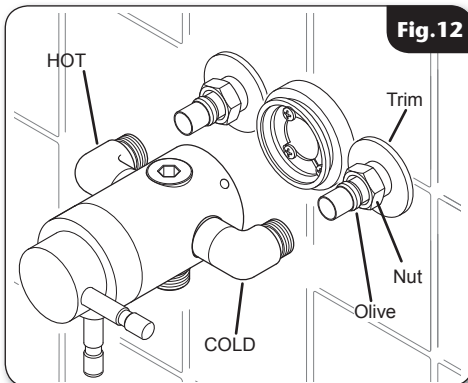

Fig.12

Tighten all compression fittings.

Tighten all the grub screws to secure the mixer to mounting plate.

### Outlet adapter and plug

The outlet adapter and plug can be repositioned dependant on the outlet required (top or bottom). The adapter is suitable for a 15mm rigid pipe connection (**fig.13**).

If the adapter is used for a 15mm rigid pipe top outlet, the 'O' ring will need to be moved from one side of the adapter to the other to provide the proper seal.

### Flow regulation

A flow regulator is supplied for use with high-pressure water systems and may be fitted with any of the systems listed to reduce flow rate and assist economy.

### To fit the flow regulator

The flow regulator for 15mm rigid pipe must be fitted into the showerhead - see (fig.16).

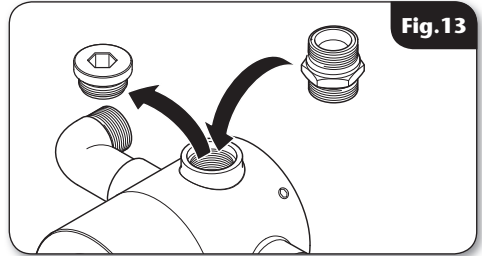

Fig.13

## FITTING THE FIXED ARM & SHOWERHEAD

**Note:** Before installation, it is advised that the mounting surface is made good to give a solid fixing point for the shower arm. It is not advised to fix the arm through plasterboard alone.

- Insert the pipework into the installed mixer valve outlet (but do not tighten into the mixer yet).

**Note:** Applying a small amount of silicon oil or similar, may ease the fitting of the assembly.

- Push the pipe sections into the connector fitting and then into the shower arm (fig.14).
- Offer the shower arm/riser assembly to the mixer outlet, making sure the rail is aligned vertically. Mark the position of the arms three fixing holes.
- Remove the assembly from the wall.
- Drill and plug the wall. (An appropriate drill bit should be used. If the wall is brick, plasterboard or a soft building block, appropriate wall plugs and screws should be fitted).
- Slide the retaining nut and olive onto the bottom section of pipework (fig.14) and insert the assembly into the mixer outlet.
- Align the assembly to the shower arm fixing holes and, using suitable screws, secure the arm to the wall.
- To secure the pipework to the mixer, then slide the olive and nut down onto the mixer outlet and tighten.

**WARNING!**  
Check there are no hidden cables or pipes before drilling holes for wall plugs. Use great care when using power tools near water. The use of a residual current device (RCD) is always recommended.

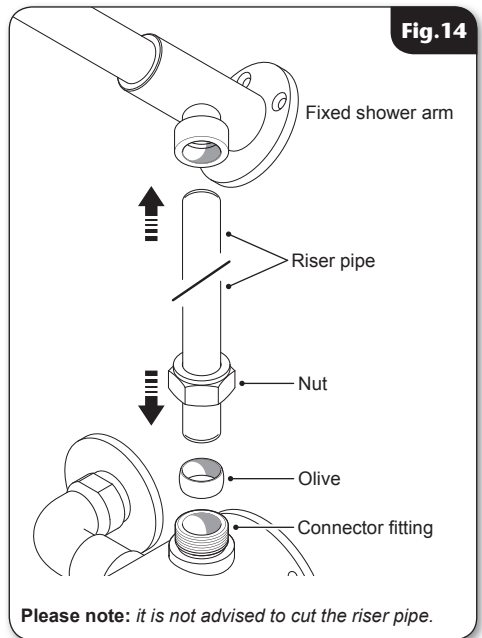

Fig.14

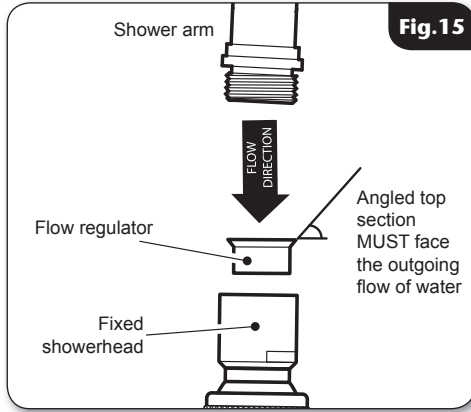

Fig.15

### Fitting the fixed showerhead

- Screw the fixed head (**fig.15**) to the shower arm.
- Make sure that the flow regulator is in the correct orientation (if being fitted). The correct orientation is to have the angled top section facing the outlet flow of water.
- Check that the sealing washer is in place.
- Screw the showerhead tight to seal the joint

### ANTI-SCALD PROTECTION

It is important that the mixer valve is tested regularly to prevent the risk of scalding and guarantee user safety. This can be carried out as follows: with the mixer blend temperature set at 38°C isolate the cold water supply. The outlet flow rate will reduce to a safe level.

### LEAK TESTING

Direct the outlet of the mixer to waste. Open the isolating valves to the shower and check for leaks. Remedy any leaks found.

### COMMISSIONING

Start the water flow by rotating the flow control.

Make sure that both the hot and cold water supplies are fully open and at (or near to) their design temperature and pressures, and are within the requirements as stated.

Make sure the temperature control is at the maximum temperature setting.

Allow the shower to run at the maximum temperature setting until the water temperature has stabilised. Rotate the temperature control until your desired maximum showering temperature is reached.

The mixer has a temperature stop to prevent accidental rotation to higher temperatures. This is adjustable to provide a maximum temperature of 35°C - 45°C and should be checked on site to guarantee user safety.

### Temperature adjustment range

The mixed water temperature can be adjusted from cold through to a top limit (which can be pre-set during installation – factory set at approximately 38°C) with full anti-scald protection throughout the range.

## ADJUSTING THE MAXIMUM TEMPERATURE SETTING (and fitting the levers)

The maximum temperature stop factory set to 38°C (this can be adjusted during installation).

**Note: Before fitting the levers the maximum temperature should be checked on site to guarantee user safety**

- To adjust the maximum temperature setting, remove the temperature control knob.
- Allow the water to run until the temperature has stabilised, adjust the temperature control spindle by hand (**fig.16**).
- When the showering temperature is satisfactory turn off the shower.
- Fit the temperature knob, making sure the maximum temperature stop pin is as close to the flat edge of the maximum temperature stop as possible (**fig.17**).
- To assemble the flow and temperature controls, please see (**fig.18**) (see fig.17 for the position of the maximum temperature stop). Secure the controls in place with the retaining grub screws and fit the levers (**fig.18**).

### Recommended outlet temperatures

The BuildCert TMV scheme recommends the following set maximum mixed water outlet temperatures for use in all premises:

44°C - for bath fill but see notes below.

41°C - for showers.

41°C - for washbasins.

38°C - for bidets.

The mixed water temperatures must never exceed **46°C** at terminal fitting.

The British Burns Association recommends **37 to 37.5°C** as a comfortable bathing temperature for children. In premises covered by the Care Standards Act 2000, the maximum mixed water outlet temperature is **43°C**.

Fig.16

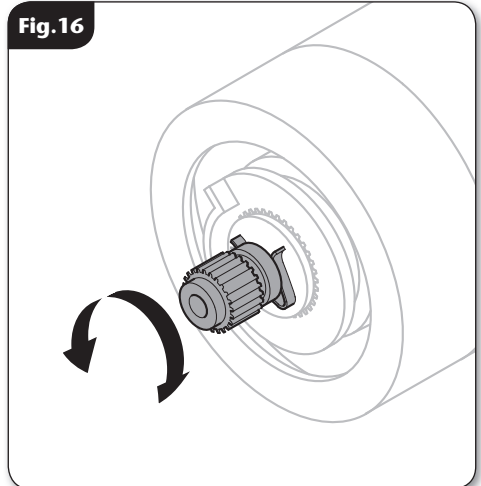

Fig.17

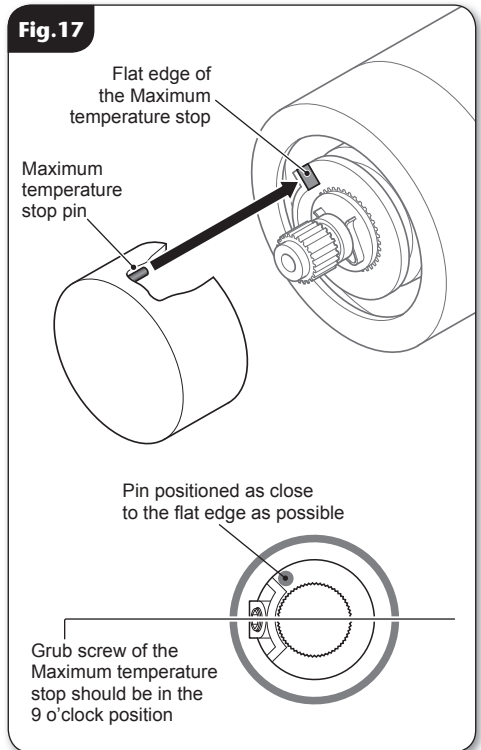
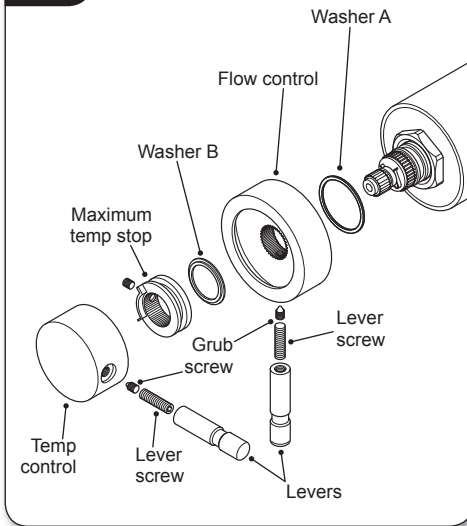

Fig.18



**OPERATING THE SHOWER (fig.19)**

- To start the shower, turn the On/Off flow control clockwise until it hits the stop for maximum flow.
- To stop the shower, turn the On/Off flow control anti-clockwise until it hits the stop.
- To adjust the showering temperature rotate the temperature control – clockwise for cooler and anti-clockwise for hotter.

**CAUTION: Exposed metal surfaces may become hot during use.**

Fig.19

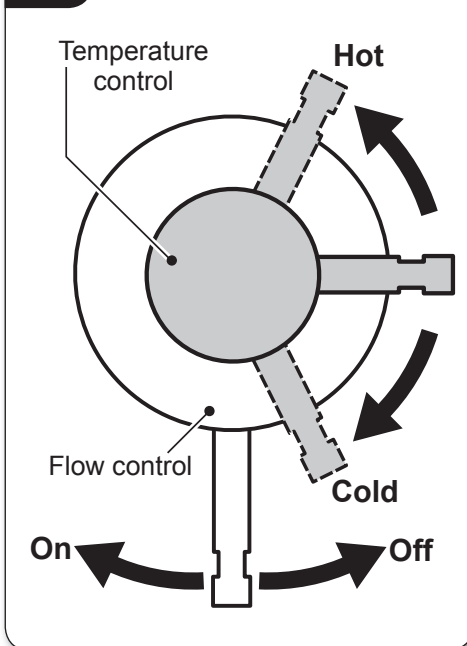

## APPROVALS

This mixer valve has been designed to comply with the requirements of: **BS EN 1111**  
**BS EN 1287**  
**WRAS**

## FLOW CHART

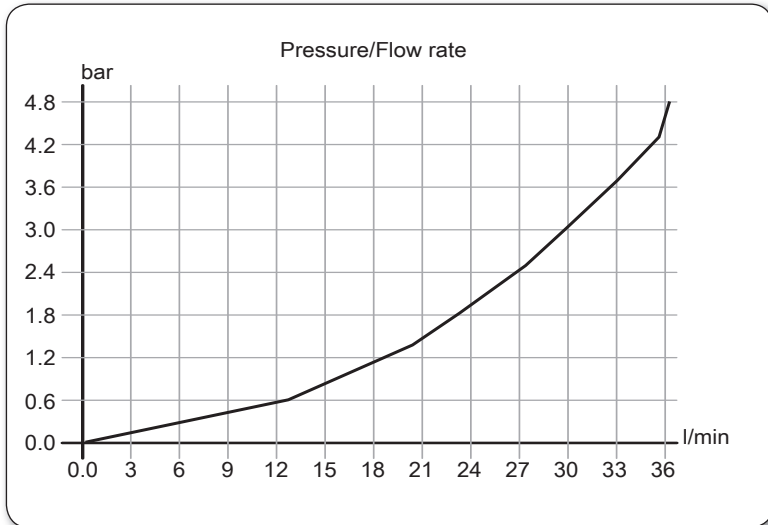

- Flow rate at 38°C
- Flow control fully open
- Open outlet
- No flow regulator fitted

## DIMENSIONS

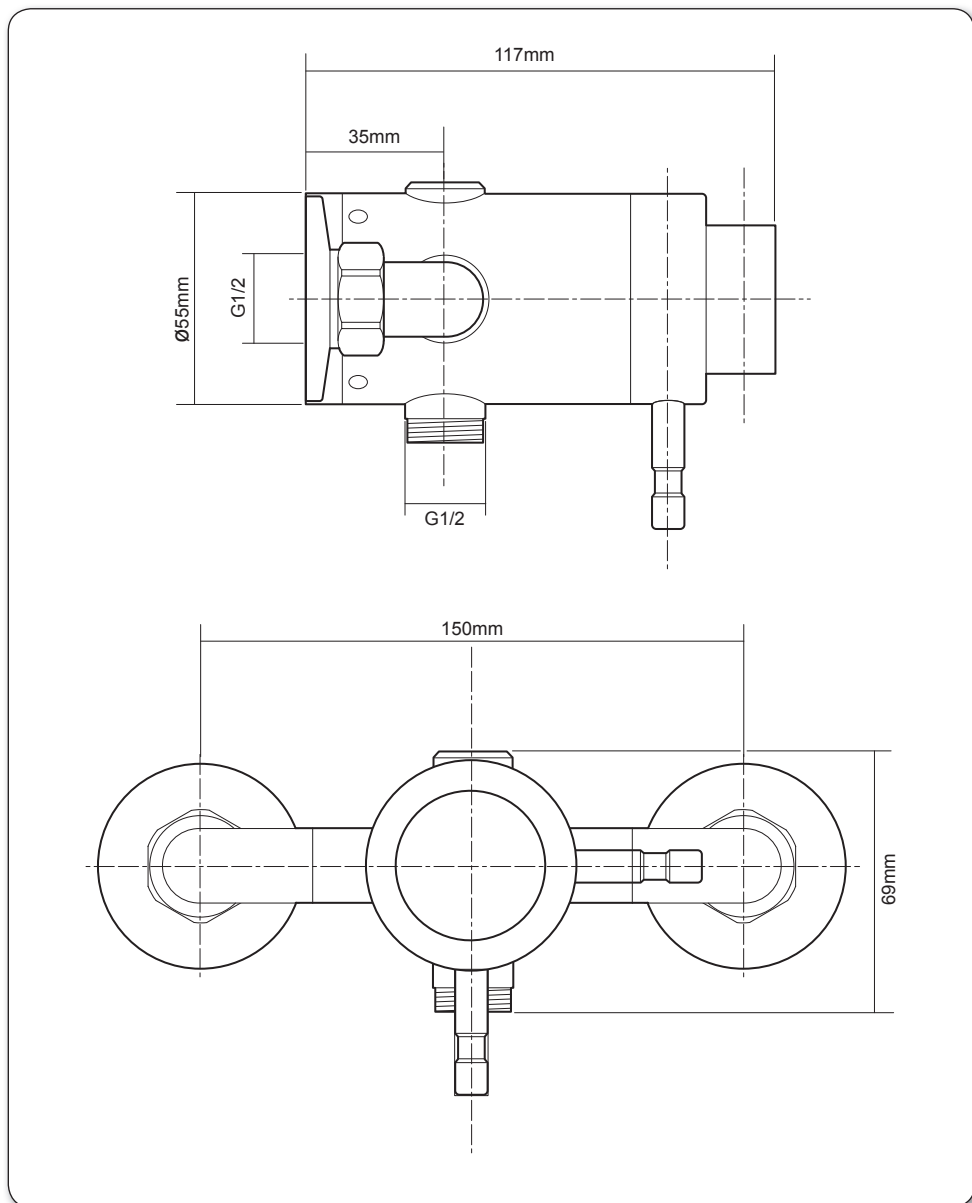

All dimensions listed in this fitting book regarding the product and installation are approximate.



## Concentric exposed thermostatic mixer shower

### SPARE PARTS

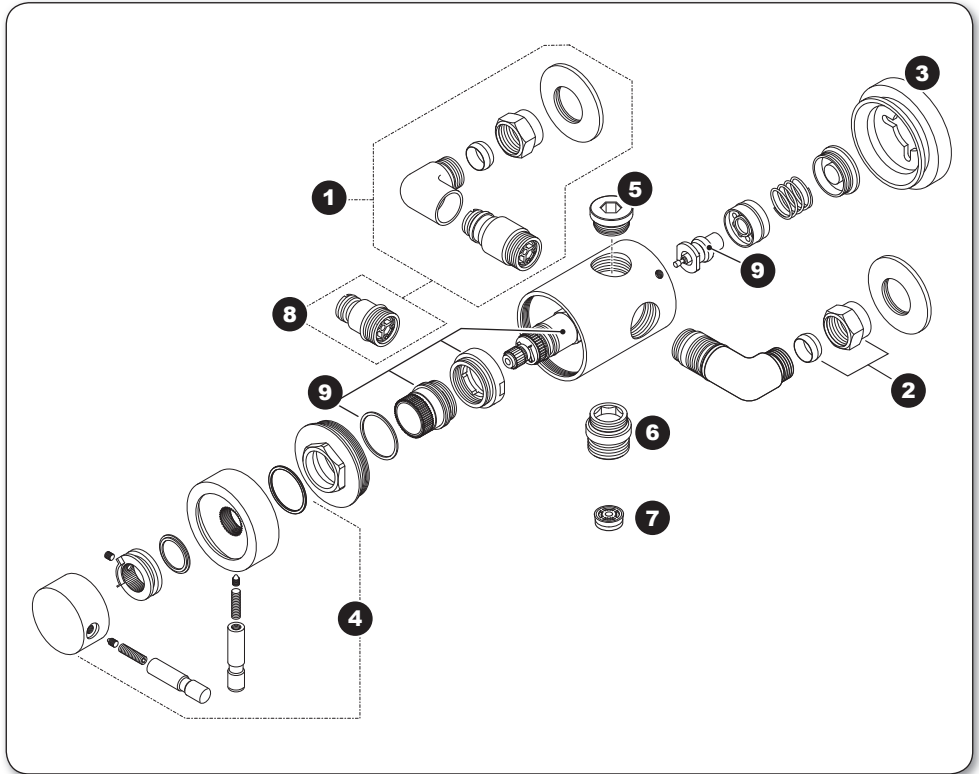

Ref.	Description	Part No.	Ref.	Description	Part No.
1.	Elbow assembly complete:	83313870	7.	Flow regulators are available from Triton at the following ratings:	
2.	Nut and Olive	83312790		(3 Ltr/min)	22010310
3.	Mounting plate	83313890		(4 Ltr/min)	22011740
4.	Handle assembly	86003860		(5 Ltr/min)	22011750
5.	Plug	83313900		(6 Ltr/min)	22011760
6.	Adapter	83313910		(7 Ltr/min)	22011610
				(8 Ltr/min) Supplied	22011280
			8.	110mm adaptor <i>not supplied</i>	86003140
			9.	Service kit	83314150
			-	1m riser pipe <i>not show</i>	88400023

## MAINTENANCE

The following maintenance procedure must be carried out for commercial and health care premises, but is not necessarily required for domestic installations.

Maintenance of the unit is required to give continued performance after installation and that it continues to provide scald prevention.

Note: A thermostatic mixing valve in need of maintenance can be undetectable in normal use and only becomes apparent when a disruption occurs in the hot or cold water supply temperatures or pressures.

The frequency of routine maintenance of the internal of the valve will depend mainly on the water supply condition. Experience of local conditions will dictate the intervals for inspection and in-service testing; guidance has been given below which can be adjusted for local requirements.

- a) Initially check the filters for debris once every three months and clean if necessary.
- b) Perform a thermal shut off test every three months, and check the maximum temperature setting. See the 'Commissioning' section for the details of this test and readjustment of the maximum temperature setting if required.
- c) If the maximum water temperature varies by more than 2°C from the commissioned setting then carry out the following checks
  - Check the isolating valves are fully open.
  - Check the internal surface for scaling.

If the body requires descaling then it should be removed from the pipework to carry this work out (all rubber parts must be removed before descaling).

- Check the function of the non-return valves

The non-return valves (NRVs) prevent cross-flow between hot and cold supplies under unequal pressure conditions. They are designed for long life with no maintenance.

If these checks do not highlight the reason for the temperature variation, then internal components will require replacement; please see the spare parts list.

## Cleaning

Triton recommends that all products are cleaned using warm, soapy water.

Do not use abrasive or aggressive chemical cleaning products as this may affect the product surface finish and invalidate your guarantee.

## Cleaning the filters (fig.A)

It is advised that this should be carried out by a qualified person.

- Turn off the water supplies before starting.
- Remove Hot and Cold elbows.
- Loosen the retaining grub screw and pull the adaptor from the elbow assembly.
- Remove the retaining clip and valve.
- Wash the filter thoroughly under running water, use a suitable brush to remove all debris.
- Reassemble in reverse order.

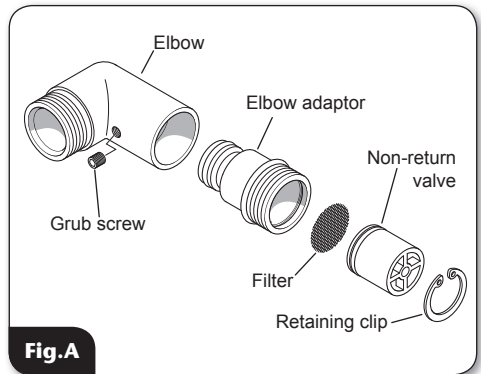

Fig.A

## Disinfection

Where chlorine is used for the disinfection of water systems all relevant guidelines and approved codes of practice must be strictly followed. Failure to comply with the relevant guidelines and approved codes of practice may invalidate your guarantee.

### WARNING!

**DO NOT use 'powerful' abrasive or solvent cleaning fluids when cleaning the shower as they may damage the fittings.**

## FAULT FINDING

### The following can be carried out by a competent person

<b>Problem/Symptom</b>	<b>Cause</b>	<b>Action/Cure</b>
<b>1</b> Water too hot.	<b>1.1</b> Temperature control incorrectly commissioned.	<b>1.1.1</b> Refer to commissioning section.
	<b>1.2</b> Not enough cold water flowing through shower.	<b>1.2.1</b> Reposition the temperature control.
	<b>1.3</b> Increase in the ambient cold water temperature.	<b>1.3.1</b> Reposition the temperature control.
	<b>1.4</b> Cold water supply blocked.	<b>1.4.1</b> Turn off shower and consult a competent plumber or contact Customer Service.
	<b>1.5</b> High volume of cold water drawn off elsewhere.	<b>1.5.1</b> Reduce the simultaneous demand from the mains supply.
<b>2</b> Water too cold.	<b>2.1</b> Temperature control incorrectly commissioned.	<b>2.1.1</b> Refer to commissioning section.
	<b>2.2</b> Not enough hot water flowing through shower.	<b>2.2.1</b> Reposition the temperature control
	<b>2.3</b> Decrease in the ambient cold water temperature.	<b>2.3.1</b> Reposition the temperature control
	<b>2.4</b> Insufficient hot water supplies from the heating system.	<b>2.4.1</b> Make sure heating appliance is set to maximum or has sufficient stored hot water.
		<b>2.4.2</b> Make sure heating appliance is igniting by trying a hot water tap elsewhere.
<b>2.5</b> Hot water supply blocked or restricted.	<b>2.5.1</b> Turn off shower and consult a competent plumber or contact Customer Service.	
<b>3</b> High water flow and/or poor performance on a mains fed system.	<b>3.1</b> Flow regulator not fitted.	<b>3.1.1</b> Fit the supplied flow regulator ( <i>see 'To fit a flow regulator' on page 9</i> ).

### FAULT FINDING

<b>Problem/Symptom</b>	<b>Cause</b>	<b>Action/Cure</b>
<b>4</b> Water does not flow or shower pattern collapses when another outlet is turned on.	<b>4.1</b> Water supplies cut off.	<b>4.1.1</b> Check water elsewhere in house and if necessary contact local water company.
	<b>4.2</b> Shower unit blocked.	<b>4.2.1</b> Inspect the filters. Clean if necessary.
	<b>4.3</b> Blockage in pipework.	<b>4.3.1</b> Turn off the shower and consult a suitably competent plumber.
	<b>4.4</b> Showerhead blocked.	<b>4.4.1</b> Clean the showerhead.
	<b>4.5</b> System not capable of supplying multiple outlets at the same time.	<b>4.5.1</b> Reduce the simultaneous demand.
<b>4.5.2</b> Make sure stop or service valve is fully open.		
<b>4.5.3</b> Check if there is sufficient water pressure.		
<b>The following is recommended for a professional qualified installer only</b>		
<b>5</b> Water too cold.	<b>5.1</b> Running pressure is excess of maximum recommended.	<b>5.1.1</b> Fit a pressure reducing valve.
<b>6</b> Shower controls noisy when in use.	<b>6.1</b> Running pressure in excess of maximum recommended.	<b>6.1.1</b> Fit a pressure reducing valve.
<b>7</b> Shower will not shut off.	<b>7.1.</b> Pipework not flushed out before connecting to the unit. Internal components damaged.	<b>7.1.1</b> Service valve.







## UK SERVICE POLICY

In the event of a product fault or complaint occurring, the following procedure should be followed:

1. Telephone Customer Service on **0844 980 0750** having available, your details including post code, the model number and power rating of the product, together with the date of purchase.
2. Based on information given over the telephone, a Triton Customer Service Advisor will attempt to diagnose the fault and confirm whether a site visit from a qualified service engineer is required.
3. All products attended to by a Triton service engineer must be installed in full accordance with the Triton installation guide applicable to the product. *(Every product pack contains an installation guide, however, they can also be bought via our Customer Service Spares Department).*
4. Our engineer will require local parking and if a permit is required this must be available to the engineer on arrival at the call.
5. It is essential that you or an appointed representative (*who must be over 18 years of age*) is present for the duration of the service engineer's visit. If the product is in guarantee you must produce proof of purchase.
6. Where a call under the terms of guarantee has been booked and the failure is not product related (*i.e. scaling and furring, incorrect water pressure, pressure relief device operation or electrical/plumbing installation fault*) a charge will be made. A charge will also be issued if nobody is at home when the service engineer calls or adequate parking/permit is not available.
7. If the product is no longer covered by the guarantee an up front fixed fee will be charged before the site visit.
8. Should proof of purchase not be available on an "in-guarantee" call, or should the service engineer find that the product is no longer under guarantee, the engineer will charge the same fixed price and the customer will be expected to pay the engineer before he leaves. If payment is not made on the day an administration charge will be added to the fixed charge.
9. If a debt is outstanding from a previous visit, or from any other Triton purchase. Triton reserves the right to withhold service until the debt has been settled.
10. Triton takes the health, safety and wellbeing of its employees very seriously and expects customers to treat all staff members with respect. Should any employee feel threatened or receive abuse, either verbally or physically, Triton reserves the right to withhold service and will support the employee with a legal prosecution.

## Replacement Parts Policy

**Availability:** It is the policy of the manufacturer to maintain parts availability for the duration of production and a period of five years thereafter, in accordance with industry standards.

Spare parts are available via our website, **www.tritonshowers.co.uk**, or by telephoning Triton Customer Service Spares Department. Payment should be made by credit/debit card (*excluding American Express or Diners Card*).

Payment can also be made by pre-payment of a pro forma invoice by cheque or money order.

## TRITON STANDARD GUARANTEE

Triton guarantee this product against all mechanical defects arising from faulty workmanship or materials for a period of five years for domestic use only, from the date of purchase, provided that it has been installed by a competent person in full accordance with the fitting instructions.

Any part found to be defective during this guarantee period we undertake to repair or replace at our option without charge so long as it has been properly maintained and operated in accordance with the operating instructions, and has not been subject to misuse or damage.

This product must not be taken apart, modified or repaired except by a person authorised by Triton. This guarantee applies only to products installed within the United Kingdom and does not apply to products used commercially. This guarantee does not affect your statutory rights.

### What is not covered:

1. Breakdown due to: **a)** use other than domestic use by you or your resident family; **b)** wilful act or neglect; **c)** any malfunction resulting from the incorrect use or quality of electricity, gas or water or incorrect setting of controls; **d)** failure to install in accordance with this installation guide.
2. Repair costs for damage caused by foreign objects or substances.
3. Total loss of the product due to non-availability of parts.
4. Compensation for loss of use of the product or consequential loss of any kind.
5. Call out charges where no fault has been found with the appliance.
6. Call out charges where the water supply cannot be isolated, this includes consequential losses arising from unserviceable supply valves.
7. The cost of repair or replacement of pressure relief devices, showerheads, hoses, riser rails and/or wall brackets, isolating switches, electrical cable, fuses and/or circuit breakers or any other accessories installed at the same time.
8. The cost of routine maintenance, adjustments, overhaul modifications or loss or damage arising therefrom, including the cost of repairing damage, breakdown, malfunction caused by corrosion, furring, pipe scaling, limescale, system debris or frost.

**Customer Service:** ☎ **0844 980 0750**

**Trade Installer Hotline:** ☎ **0844 980 0730**

**Fax:** **0844 980 0744**

**www.tritonshowers.co.uk**

**E-mail:** **serviceenquiries@tritonshowers.co.uk**

Triton Showers  
Triton Road  
Nuneaton  
Warwickshire CV11 4NR

*Triton is a division of Norcros Group (Holdings) Limited*