

SARO

Concentric Thermostatic Mixer Shower

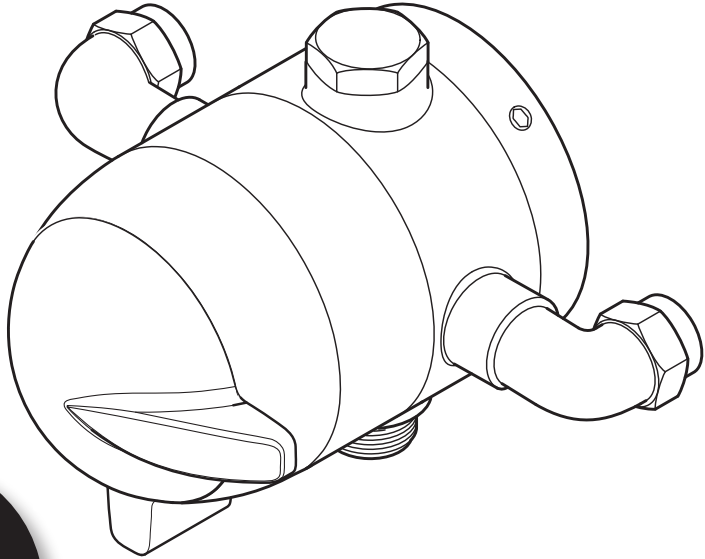

Installation and operating instructions

Covering: Exposed and Built in fitting

INSTALLERS PLEASE NOTE THESE INSTRUCTIONS ARE TO BE LEFT WITH THE USER

CONTENTS

Page

MAIN COMPONENTS.....	1
INTRODUCTION.....	2
SITE REQUIREMENTS	2
SAFETY WARNINGS	2
PLUMBING REQUIREMENTS	3
WATER SYSTEM REQUIREMENTS.....	3
TYPICAL DOMESTIC INSTALLATIONS.....	4 - 6
INSTALLATION.....	7
Option 1: FITTING THE MIXER - EXPOSED.....	7 - 9
Supply pipework.....	7
Rear entry supplies.....	7
FITTING THE MIXER.....	8
Outlet adapter and plug	8
Flow regulation.....	8
To fit the flow regulator	9
Leak testing	9
Anti-scald protection.....	9
Option 2: FITTING THE MIXER - BUILT IN.....	10 - 15
Supply pipework.....	10
Rear entry supplies.....	10
BUILT-IN FITTING.....	10 - 12
FITTING THE MIXER.....	12
Outlet adapter and plug	13
FITTING THE BULKHEAD THREADED CONNECTOR	13
Leak testing	13
MAKING GOOD	14
BULKHEAD ASSEMBLY & INSTALLATION.....	14
Flow regulation.....	15
To fit the flow regulator	15
Anti-scald protection.....	15
COMMISSIONING.....	16
Temperature adjustment range.....	16
Recommended outlet temperatures.....	16
FITTING THE CONTROLS.....	17
ADJUSTING THE MAXIMUM TEMPERATURE SETTING.....	17
OPERATING THE SHOWER	18
DIMENSIONS	19
SPARE PARTS	20
APPROVALS	21
FLOW CHART	21
MAINTENANCE	22
Cleaning the filters.....	22
FAULT FINDING	23 - 24
Guarantee, service policy, etc.....	rear cover

To check the product suitability for commercial and multiple installations, please contact Triton's specification advisory service before installation.

Telephone: 0844 980 0730

Facsimile: 0844 980 0744

E mail: technical@tritonshowers.co.uk

All dimensions listed in this fitting book regarding the product and installation are approximate.
*All kits are for illustration purposes only and are not supplied unless otherwise stated.

MAIN COMPONENTS

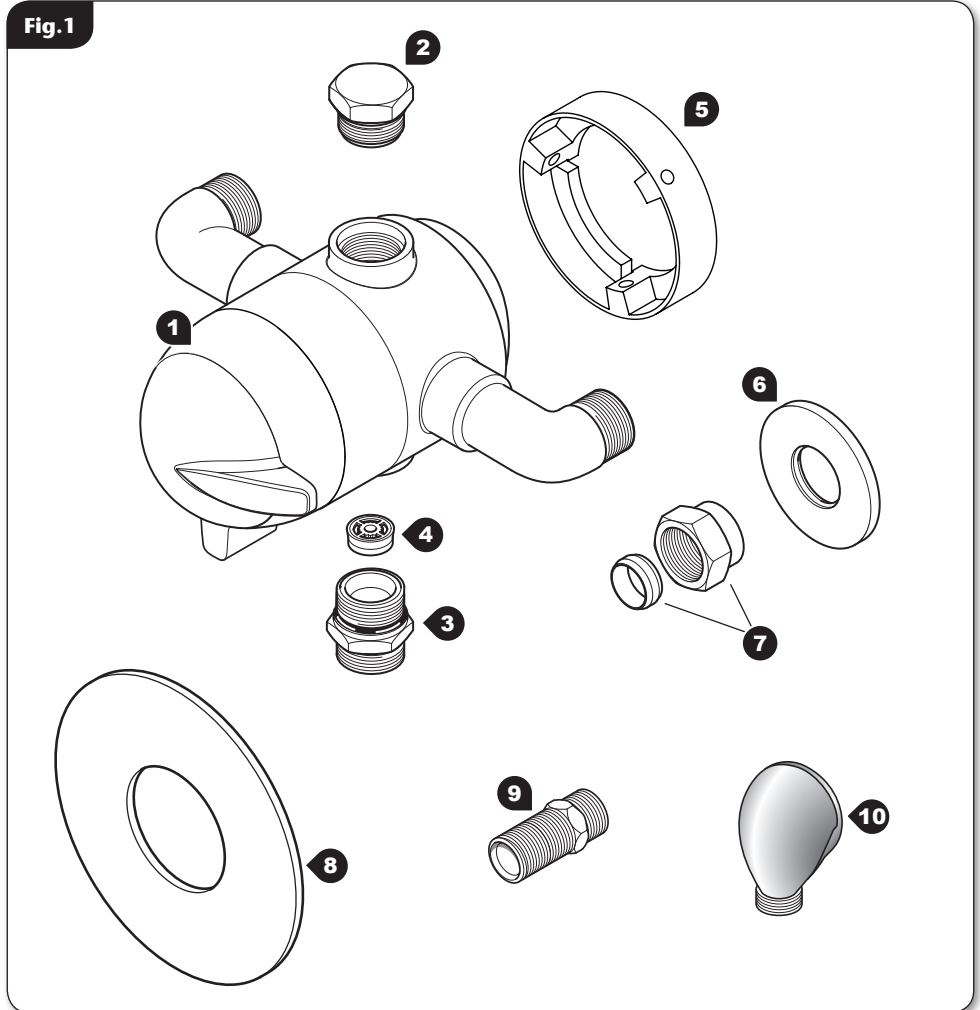

Ref. Description

- | | |
|----------------------|--------------------------------|
| 1. Mixer shower body | 6. Wall trim X2 |
| 2. Blanking plug | 7. Inlet nut and Olive X2 |
| 3. Outlet adapter | 8. Coverplate |
| 4. Flow regulator | 9. Bulkhead threaded connector |
| 5. Mounting plate | 10. Bulkhead |

INTRODUCTION

This book contains all the necessary fitting and operating instructions for your mixer shower. Please read them carefully and read through the whole of this book before beginning your installation.

The shower installation must be carried out by a suitably competent person and in sequence of this instruction book.

Care taken during the installation will give a long and trouble free life from your mixer shower.

SITE REQUIREMENTS

The installation must be in accordance with water supply (water fittings) regulation 1999 and/or local Bylaws.

Water pressure requirements

Running water pressure:

Low pressure*	- 0.1 bar min. 1.0 bar max.
High pressure	- 1.0 bar min. 5.0 bar max.

Maximum static water pressure:

Low & High pressure	- 10 bar
---------------------	----------

*This mixer shower is designed for high pressure systems found in the UK, but can be installed with low pressure gravity water systems with reduced flow rates.

For effective operation of the internal seals, the maximum static pressure must not be exceeded.

Pressure reducing valve

On sites where the running pressure is above 5 bar, the use of a suitably sized pressure reducing valve fitted in the cold mains supply pipe work can provide nominally equal pressures at the mixer shower.

Water minimum flow rate

For best performance within the specified running pressure range a minimum flow of 8 litres per minute should be available to both inlets.

Water temperature requirements

Recommended maximum:	= 65°C
Minimum hot water temperature:	= 55°C
Maximum cold water temperature:	= 25°C

A stored water temperature of 60°C is considered sufficient to meet all normal requirements and will minimise the effects of scale in hard water areas.

Water temperature adjustment and thermal safety

The mixed water temperature can be adjusted from cold through to a top limit which must be preset during installation with full anti-scald protection throughout the range (35°C to 40°C) providing the hot water temperature at the inlet remains 10°C above the outlet temperature.

Should there be a loss of flow to either incoming supply then- water from the shower will stop or be reduced until both supplies are restored.

SAFETY WARNINGS

- DO NOT** choose a position where the shower could become frozen.
- DO NOT** connect this mixer shower to any form of tap or fitting not recommended by the manufacturer.
- DO NOT** allow the inlet pressure or flow rates to operate outside the guidelines laid out in 'site requirements'.
- DO NOT** connect the mixer shower to a gravity hot supply and a mains cold supply (or vice versa).

PLUMBING REQUIREMENTS

DO NOT use jointing compounds on any pipe fittings for the installation.

DO NOT solder fittings near the mixer unit as heat can transfer along the pipework and damage the mixer valve.

DO NOT subject the unit to a water temperature above 80°C during installation, use, maintenance or disinfection.

IMPORTANT:

- The layout and sizing of pipework **MUST** be such that nominally equal inlet supply pressures are achieved and the effects of other draw-offs are minimised.
- The pipe-work should be installed such that other taps and appliances being operated elsewhere on the premises do not significantly affect the flow.
- When connecting pipe-work avoid using tight 90° elbows; swept or formed bends will give the best performance.
- The hot water pipe entry **MUST** be made to the left-hand side inlet, marked HOT, 'H' or with a red/orange label.
- Suitable isolating valves (complying with Water Regulations and Bylaws) **MUST** be fitted on the hot and cold water supplies to the shower as an independent means of isolating the water supplies should maintenance or servicing be necessary.
- It is preferable to flush the pipe-work to clear the system of debris and check for leaks before connecting to the mixer.
- The mixer inlets contain removable filters that may become blocked if debris is not flushed through before fitting.

(Commercial applications)

- It is recommended that for all commercial applications, easily accessible, in-line filters are used to aid maintenance.

PLEASE NOTE: Any reference made to 'The BuildCert TMV scheme' is for reference only. This valve is not TMV2 approved.

Hard water areas

- a. If it is intended to operate the shower in areas of hard water (above 200-ppm temporary hardness), a scale inhibitor may have to be fitted. For advice on the scale inhibitor, please contact Customer Service.
- b. For best performance the showerhead **MUST** be regularly cleaned to remove scale and debris.

WATER SYSTEM REQUIREMENTS

This mixer shower is suitable for:

- Gravity water systems.
- Pumped gravity systems.
- Fully modulating type combination boilers.
- Multi-point hot water heaters.
- Thermal storage.
- Unvented systems.

When installing this mixer with a Combination or multi-point boiler, it may be necessary to install flow regulation.

Check that the appliance is capable of delivering hot water at a minimum switch-on flow rate of 3 litres per minute. At flow rates between 3 and 8 litres per minute, the appliance **MUST** be capable of raising the water temperature to 52°C (minimum).

Water temperature at the inlet of the mixer valve **MUST** remain relatively constant when flow rate adjustments are made (refer to the appliance-operating manual to confirm compatibility with this mixer shower).

Where thermal store systems and instantaneous gas water heaters are used, if excessive draw-off take place the appliance may not be able to maintain an adequate output temperature. This could result in the shower temperature becoming noticeably cooler.

Flow regulators can be fitted with high-pressure water systems to reduce flow rate and assist economy.

The hot supply temperature **MUST** remain a minimum of 10°C hotter than the required blend temperature for optimum performance.

*Fig.2

*(diagrammatic view – not to scale)

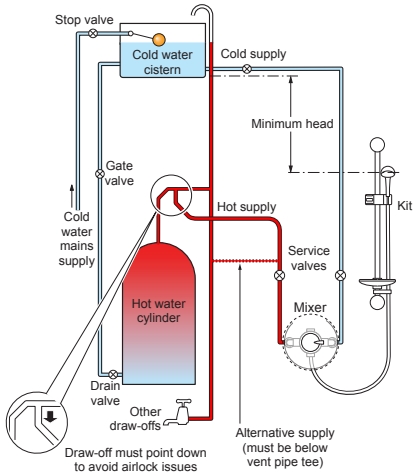

TYPICAL DOMESTIC INSTALLATIONS

Domestic gravity fed systems (fig.2)

The shower control **MUST** be fed from a cold water cistern and hot water cylinder providing nominally equal pressures. There must be a minimum of one metre head of water. The minimum head distance is measured from the base of the cold water cistern to top of the showerhead.

If valves are gravity fed then supply pressure should be verified to ensure conditions of use are appropriate for the valve.

Pumped gravity fed systems (fig.3)

The shower control **MUST** be fed from a cold water cistern and hot water cylinder providing nominally equal pressures.

The mixer unit may be used with a gravity fed system with a pump to boost pressures as shown; please refer to the pump installation guide to establish the minimum head requirements for automatic operation of the pump

*Fig.3

*(diagrammatic view – not to scale)

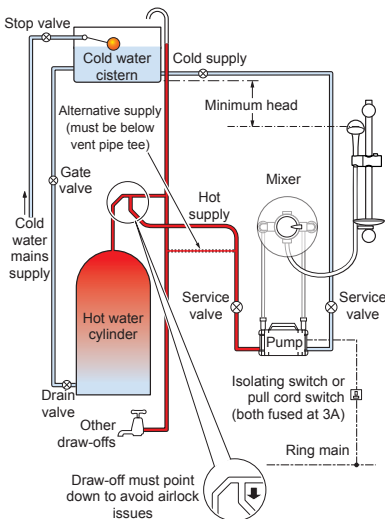

*(kits are for illustration purposes only)

Instantaneous gas-heated systems, e.g. combination boilers (fig.4)

The shower control **MUST** be installed with a multi-point gas water heater or combination boiler of a fully modulating design (i.e. to maintain relatively stable hot water temperatures).

A drop tight pressure reducing valve **MUST** be fitted if the supply pressures exceed 5 bar running.

An expansion vessel **MAY** be fitted, and regularly maintained, to prevent the shower mixer being damaged by excess pressures. This may already be installed within the boiler (check with manufacturer) and is in addition to the normally larger central heating expansion vessel.

Unvented mains pressure systems (fig.5)

The shower control can be installed with an unvented, stored hot water cylinder.

For systems with no cold water take off after the appliance reducing valve, it will be necessary to fit an additional drop tight pressure-reducing valve when the mains pressure is over 5 bar. The drop tight pressure reducing valve must be set at the same value as the unvented package pressure reducing valve.

Note: An additional expansion vessel may be required if a second pressure-reducing valve is installed. This does not apply to packages with a cold take off after the pressure-reducing valve to the cylinder.

***Fig.4**

**(diagrammatic view – not to scale)*

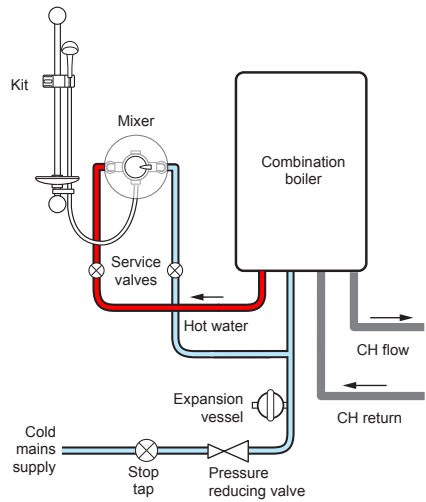

***Fig.5**

**(diagrammatic view – not to scale)*

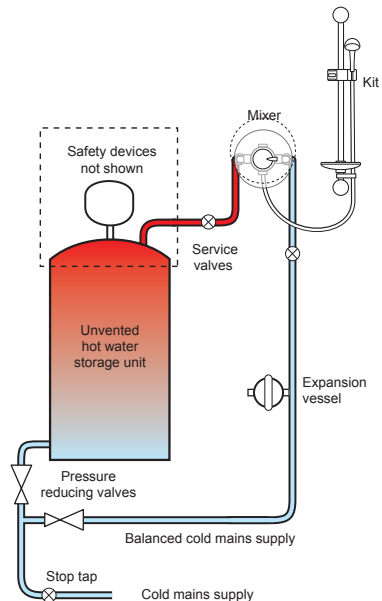

**(kits are for illustration purposes only)*

Concentric Thermostatic Mixer Shower

***Fig.6**

**(diagrammatic view – not to scale)*

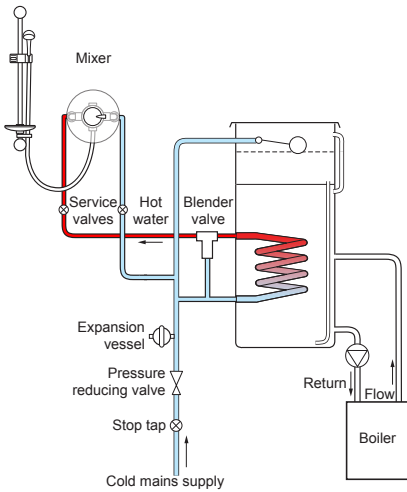

Mains pressurised thermal store systems (fig.6)

Packages of this type, fitted with a tempering valve (blender valve) can be used. A drop tight pressure reducing valve **MUST** be fitted if the supply pressures exceed 5 bar running.

An expansion vessel **MUST** be fitted, and regularly maintained, to ensure, the unit, is not damaged by excess pressures. This may already be installed externally or internally within the thermal store (check with thermal store manufacturer).

**(kits are for illustration purposes only)*

INSTALLATION

Preparing the mixer valve

Check the contents to make sure all parts are present.

Before starting the mixer installation, make sure all the openings on the valve are carefully covered to stop ingress of any debris, etc. while routing the supply pipework.

The shower valve is suitable for exposed installation onto solid wall, a stud partition wall, dry lined wall or fixing to a laminate cubicle or panel.

Siting of the shower and accessories

Refer to **(fig.7)** for correct siting of the shower.

The mixer valve should be positioned, as detailed, with all controls within comfortable reach of the user.

The accessories (showerhead, riser rail and/or fixed showerhead) can be positioned above or to either side of the shower, refer to **(fig.7)**.

The valve must be installed in a position that allows for easy access for future maintenance and commissioning.

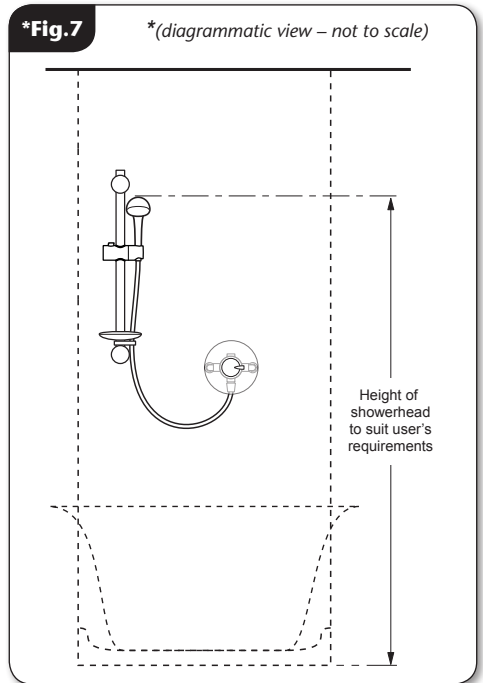

Option 1: FITTING THE MIXER - EXPOSED

Supply pipe work

Complete the pipework to the shower area having decided on the position of the shower and direction of pipe entry (for example rising, falling or rear entry)

The hot and cold water pipes should not be permanently attached to the wall within one metre of the valve before installation is complete, to allow for final adjustment of the valve position.

Rear entry supplies

Using a spirit level, mark the route of incoming hot and cold water supply pipes at a distance of 150mm (approximately) between centres **(fig.8)**.

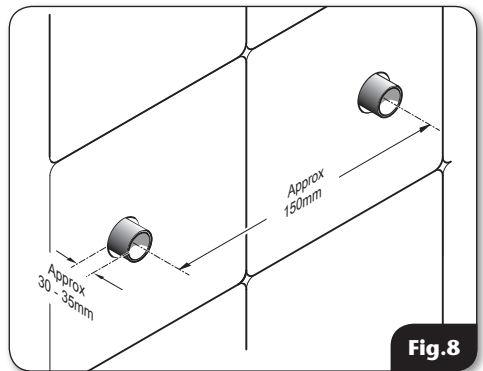

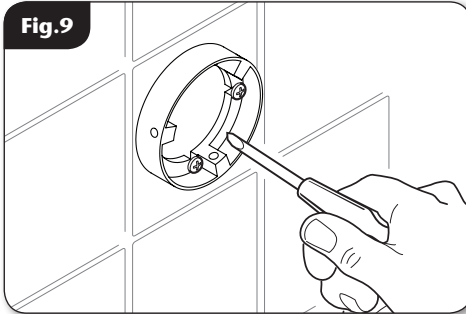

Fig. 9

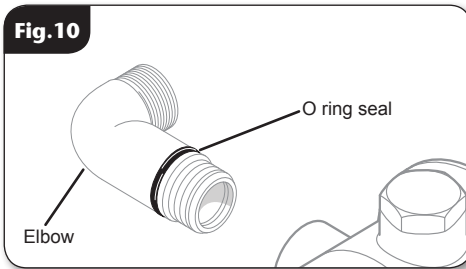

Fig. 10

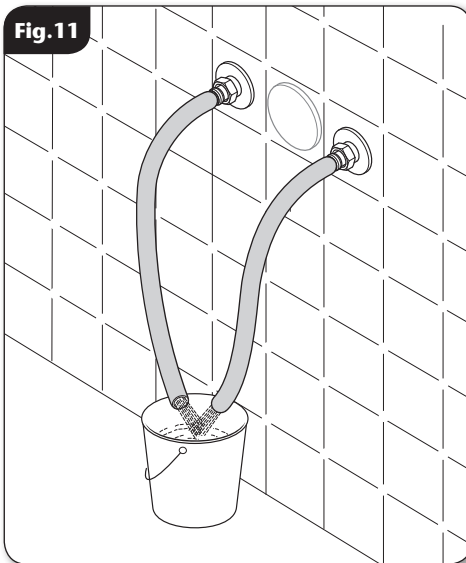

Fig. 11

FITTING THE MIXER

- Mark the position of the three locating screws for the mounting plate. If installing onto a solid brick wall, two screws fitted diagonally will usually be enough.
- Drill and plug the wall.
(An appropriate drill bit should be used. If the wall is brick, plasterboard or a soft building block, appropriate wall plugs and screws should be fitted).
- Fit the mounting plate onto the wall (**fig. 9**).
- The inlet elbows allow for either rising, falling or rear entry hot and cold water supplies. The elbows have 'O' ring seals (**fig. 10**) to the body and do not require PTFE tape or other means of sealing.

IMPORTANT: Make sure that all the supply pipework has been flushed through before fitting the mixer (**fig. 11**).

- Make good the wall and complete the tiling.
- Fit the trims onto the inlet water pipes followed by the nuts and olives (**fig. 12**).
- Connect the hot water supply to the inlet marked **HOT**, '**H**' or red/orange label and connect the cold water supply to the inlet marked **COLD**, '**C**' or blue label (**fig. 12**).
- Tighten all of the compression fittings.
- Tighten all of the grub screws to secure the mixer to the mounting plate.

Outlet adapter and plug

The outlet adapter and plug can be repositioned dependant on the outlet required (top or bottom). The adapter has two end fittings, one is suitable for a 15mm rigid pipe connection and the other is a flexible hose connection. The 'O' ring may need to be removed if it is not on the appropriate side of the hex nut and placed onto the opposite side.

Flow regulation

A flow regulator is supplied for use with high-pressure water systems and may be fitted with any of the systems listed to reduce flow rate and assist economy.

To fit the flow regulator

To fit the flow regulators (flexible hose connection) unscrew the outlet adapter. Place the flow regulator, in the correct orientation, into the rigid pipe connection end.

Note: the flow regulator is only designed to work in one direction (fig. 13).

If a 15mm rigid pipe is to be used, the flow regulator **MUST** be fitted into the showerhead. It **MUST** not be installed into the mixer outlet.

LEAK TESTING

Direct the outlet of the mixer to waste. Open the isolating valves to the shower and check for leaks. Remedy any leaks found.

ANTI-SCALD PROTECTION

It is important that the mixer valve is tested regularly to prevent the risk of scalding and guarantee user safety. This can be carried out as follows: with the mixer blend temperature set at 38°C isolate the cold water supply. The outlet flow rate will reduce to a safe level.

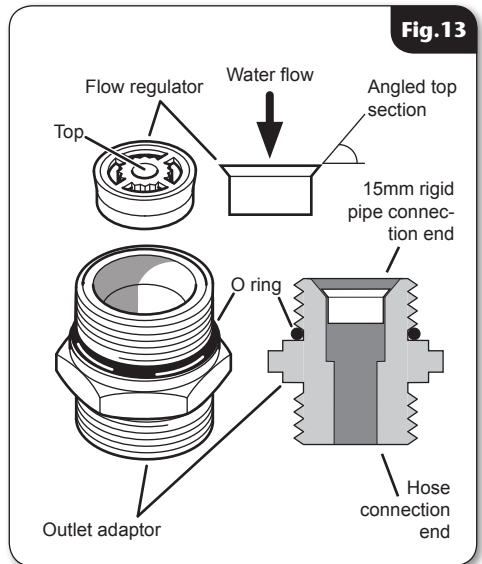
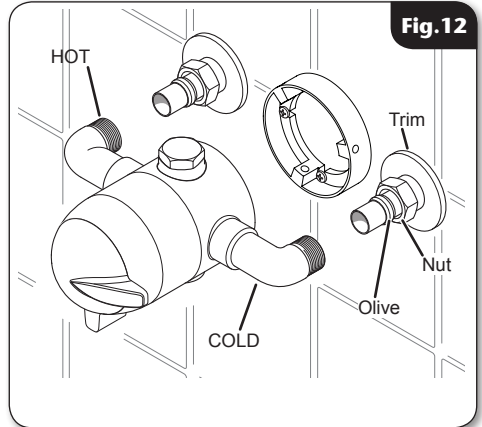

Option 2: FITTING THE MIXER - BUILT IN

Fig.14

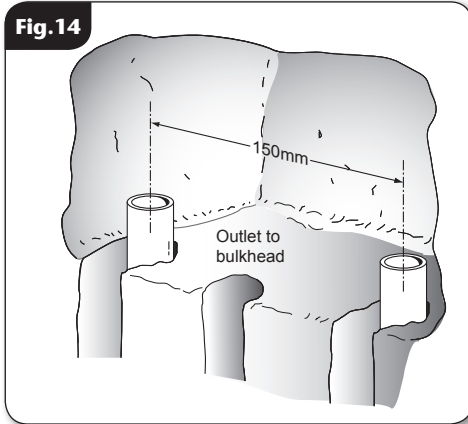

Supply pipe work

Complete the pipework to the shower area having decided on the position of the shower and direction of pipe entry (for example rising, falling or rear entry)

The hot and cold water pipes should not be permanently attached to the wall within one metre of the valve, before installation is complete, to allow for final adjustment of the valve position.

Rear entry supplies

Using a spirit level, mark the route of incoming hot and cold water supply pipes at a distance of 150mm (approximately) between centres (**fig.14**).

Fig.15

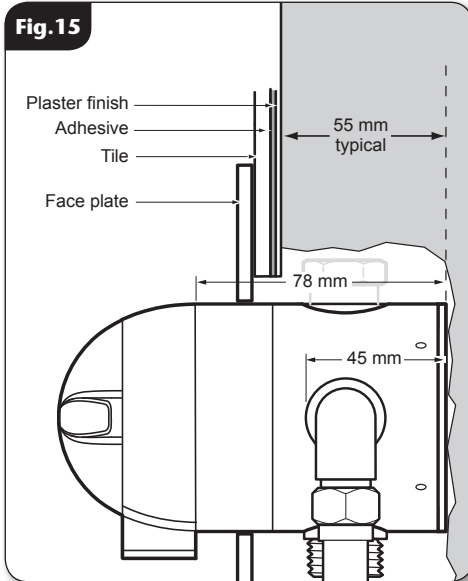

BUILT-IN FITTING

The following are typical thicknesses and are given as a guide only:

Tile	6 – 10mm
Adhesive	2 – 3mm
Plasterboard	9.5 – 12.5mm
Plaster finish	2 – 3mm

Maximum tile thickness to be 10mm.

When installing into a stud partition or other hollow wall structure, the installer may wish to consider building rear supports or other options for fitting the mounting plate - *such options are beyond the scope of this guide.*

- Use the supplied cover plate or tiling shroud as a template when cutting the opening for installing the shower into a solid wall, stud partition or hollow wall structure.

The building-in depth for the mounting plate is given in (**fig.15**) from the plaster finish but this is dependent upon tile and adhesive thicknesses.

The inlet elbows allow for either rising, falling or rear entry hot and cold water supplies. The elbows have 'O' ring seals (**fig.16**) to the body and do not require PTFE tape or other means of sealing.

Fig.16

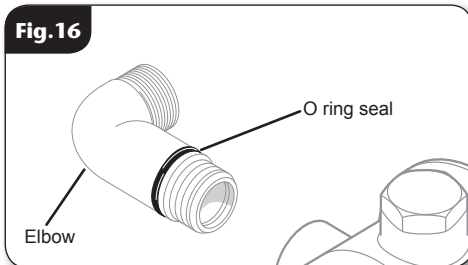

Note: To ease future requirements for cleaning and maintenance of the unit, it is advisable to route both the incoming and outgoing pipework from the same direction.

Installation in a solid wall

- Decide on the shower position and determine whether the hot and cold water supplies will enter the shower from top (falling) or bottom (rising) or rear.

As a guide for the size of hole, it should be large enough to accept the valve complete with the inlet and outlet fittings and also allow access for connection to the pipework.

- Remove the plaster and brickwork to the required depth and chase out any additional areas of the wall to give access to the pipework to and from the valve plus any outlet fittings. Note that the valve body requires a deeper recess than the inlet and outlet fittings.

Note: The outlet pipework must end in a suitable female thread parallel 15mm x 1/2" BSP fitting (not supplied).

- Offer the valve body up to the wall and mark the fixing holes. Remove the valve, drill and plug the wall. Route the pipework to valve body position.

Installation in a hollow wall

- Decide on the shower position and determine whether the hot and cold water supplies will enter the shower from the top (falling) or bottom (rising) or rear (**fig.17**).

When installing into a stud partition or other hollow wall structures, the installer will need to consider fabricating rear supports or other options - such options are beyond the scope of this guide.

- Mark the route of the incoming and outgoing pipework.
- Take out the plasterboard (use the cover plate or tiling shroud as a template). Offer the valve body up to the fabrication and mark the two fixing holes.
- Remove the valve and drill the holes. Route the pipework to the valve position.

Fig.17

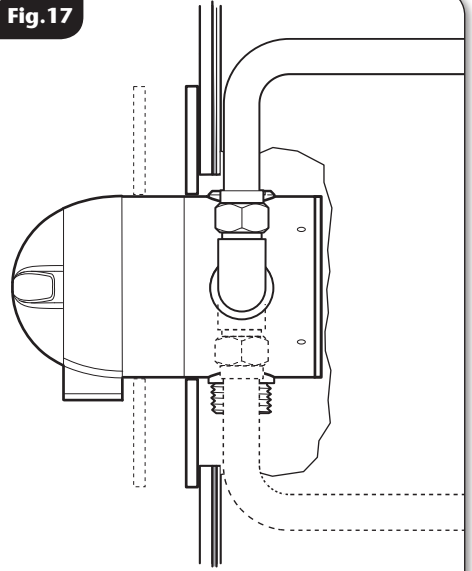

DO NOT tile or plaster up to the valve, this is to allow for service access.

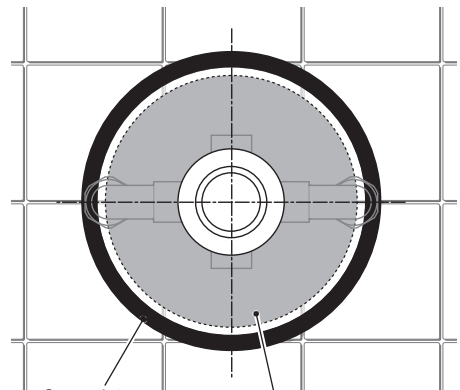

Coverplate seal

Grey area denotes the Ideal gap left around the unit for service purposes

NOTE: It is important that the plaster work, or tiles, create a good seal with the coverplate to stop any water ingress. The coverplate seal fit, should be checked before the wall is finally made good.

Fig.18

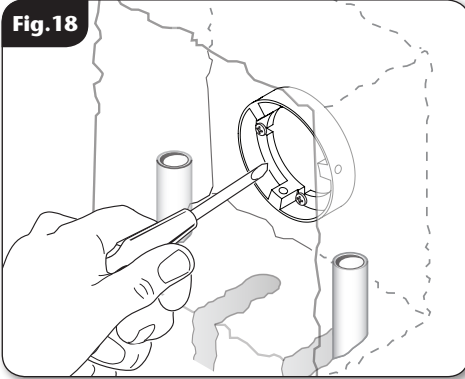

Installation in a panel or cubicle

When installing into a panel or cubicle structure the installer will need to consider fabricating rear supports or other options - *Such options are beyond the scope of this guide.*

Typically, there should be at least 65mm space from the surface of the panel to the rear of the valve body.

IMPORTANT: *Access to the rear of the valve must be available.*

The controls require one hole to be cut out of the panel or cubicle. Use the face plate as a template to mark the hole positions then extend further to allow access for the filters.

Route the pipework to valve position.

Fig.19

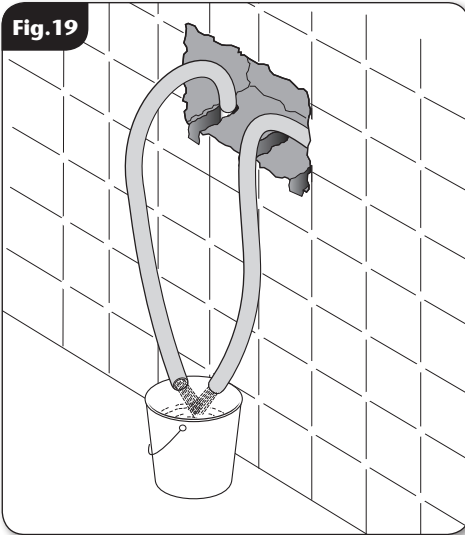

FITTING THE MIXER

- Mark the position of the four locating screws for the mounting plate. If installing onto a solid brick wall, two screws fitted diagonally will usually be enough.
- Drill and plug the wall.
(An appropriate drill bit should be used. If the wall is brick, plasterboard or a soft building block, appropriate wall plugs and screws should be fitted).
- Fit the mounting plate onto the wall **(fig.18)**.
- The inlet elbows allow for either rising, falling or rear entry hot and cold water supplies. The elbows have 'O' ring seals to the body and do not require PTFE tape or other means of sealing.

IMPORTANT: *Make sure that all the supply pipework has been flushed through before fitting the mixer (fig.19).*

- Connect the hot water supply to the inlet marked **HOT**, '**H**' or red/orange label and connect the cold water supply to the inlet marked **COLD**, '**C**' or blue label **(fig.20)**.
- Tighten all of the compression fittings.
- Tighten all of the grub screws to secure the mixer to the mounting plate.

Fig.20

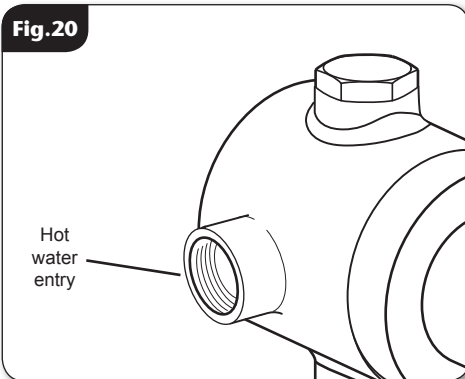

Outlet adapter and plug

The outlet adapter and plug can be repositioned dependant on the outlet required (top or bottom). The adapter has two end fittings, one is suitable for a 15mm rigid pipe connection and the other is a flexible hose connection. The 'O' ring may need to be removed if it is not on the appropriate side of the hex nut and placed onto the opposite side (**fig.21**).

FITTING THE BULKHEAD THREADED CONNECTOR

- Complete the outlet pipework ensuring it ends in an appropriate 15mm x 1/2" BSP female thread elbow (**fig.22**).

Note: *This fitting is not supplied, as variations in installations require the selection of a suitable solder or compression fitting.*

To install a fixed showerhead please refer to the fitting instruction supplied with it.

- Install the bulkhead threaded connector into the appropriate female fitting using PTFE tape to give a watertight joint.

Note: *The bulkhead threaded connector can be cut to size if required - make sure that all debris is removed from connector and the section that has been cut is dressed correctly, before installation.*

- The threaded connector should protrude from the finished wall surface by a **minimum of 8mm** and a **maximum of 13mm** (**fig.23**).

LEAK TESTING

Direct the outlet of the mixer to waste. Open the isolating valves to the shower and check for leaks. Remedy any leaks found.

Fig.21

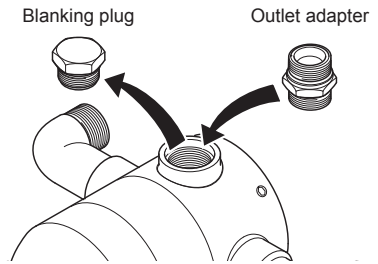

Fig.22

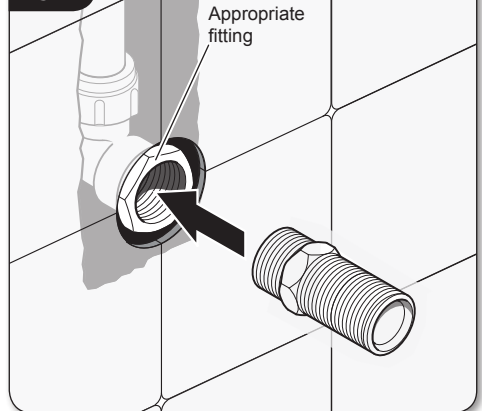
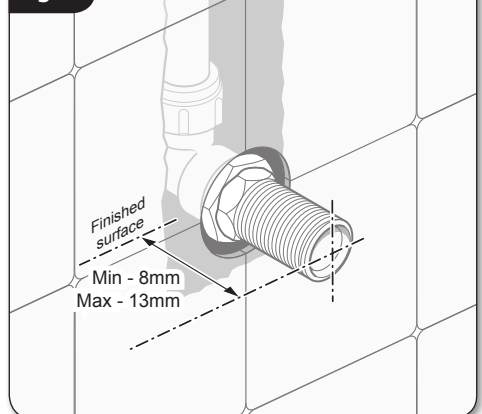
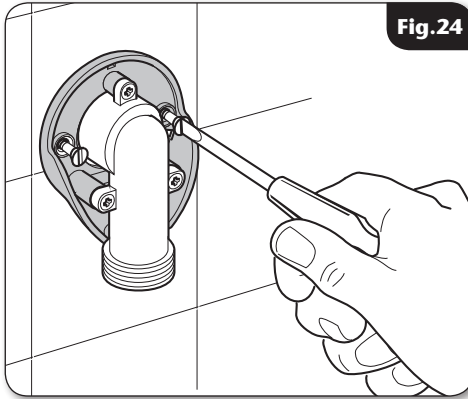

Fig.23





MAKING GOOD

Make good the wall and complete the tiling.

- If the product is supplied with a tiling shroud, it should be used to prevent damage to the product.
- If the tiles are accurately cut, then the faceplate will seal around the hole in the tiles, and the valve unit will be able to be removed from the wall without the need to break any tiles.

IMPORTANT: *Make sure the grout lines around the valve are flush with the tiles in order to provide a smooth sealing surface for the coverplate.*

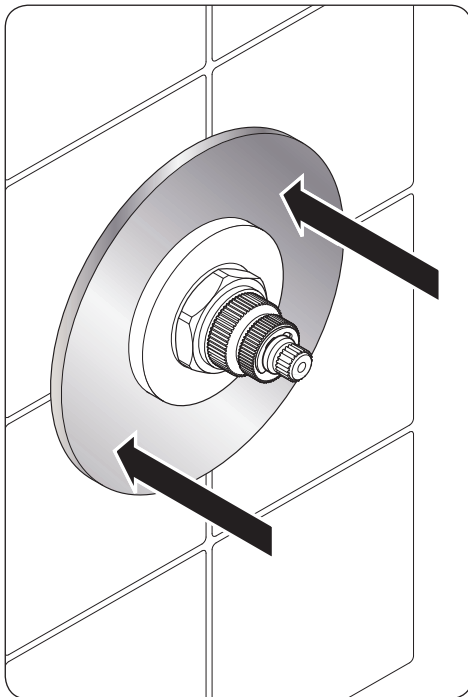

BULKHEAD ASSEMBLY & INSTALLATION

IMPORTANT: *Before bulkhead installation, check to make sure that the threaded connector falls within the specified lengths stated on Page 13.*

- Screw the bulkhead elbow to the bulkhead body with the three screws supplied.
- Screw the completed assembly onto the threaded connector temporarily to mark the position of the two fixing holes for securing the bulkhead to the wall.
- Unscrew and remove the bulkhead assembly then check the location of the pipe in the wall before drilling.
- Drill and plug the wall.
(An appropriate drill bit should be used. If the wall is brick, plasterboard or a soft building block, appropriate wall plugs and screws should be fitted).
- If fitting to a hollow wall structure, it may be preferable to secure the bulkhead by applying a bead of silicon seal to the back of the bulkhead.
- Apply PTFE tape to the threaded connector.
- Screw the bulkhead assembly onto the threaded connector until tight to the wall and the two fixing holes are aligned. Secure to the wall (**fig.24**).
- Finish by clipping the cover onto the bulkhead, making sure the protruding legs locate in the bulkhead body.

Flow regulation

A flow regulator is supplied for use with high-pressure water systems and may be fitted with any of the systems listed to reduce flow rate and assist economy.

To fit the flow regulator

To fit the flow regulator (flexible hose connection) press it into the outlet of the bulkhead, in the correct orientation.

Note: *the flow regulator is only designed to work in one direction (fig.25).*

If a 15mm rigid pipe is to be used, the flow regulator **MUST** be fitted into the showerhead.

It **MUST** not be installed into the mixer outlet.

Fitting the coverplate

- Fit the coverplate over the valve body and slide tight to the wall.
- Make sure the seal in the opening stays in place as it slides over the valve body.
- A smear of liquid soap on the seal will ease this procedure.

Note: *The coverplate incorporates a silicon sponge backing that seals against a smooth wall.*

- Once the plate has been fitted, the valve will need to be commissioned.
- Temporarily fit the controls (**fig.265**) and perform the commissioning procedure.

ANTI-SCALD PROTECTION

It is important that the mixer valve is tested regularly to prevent the risk of scalding and guarantee user safety. This can be carried out as follows: with the mixer blend temperature set at 38°C isolate the cold water supply. The outlet flow rate will reduce to a safe level.

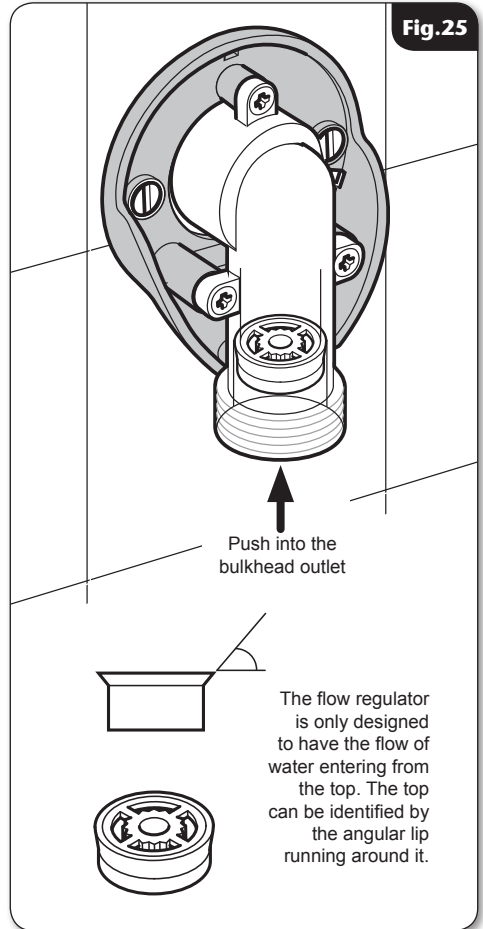
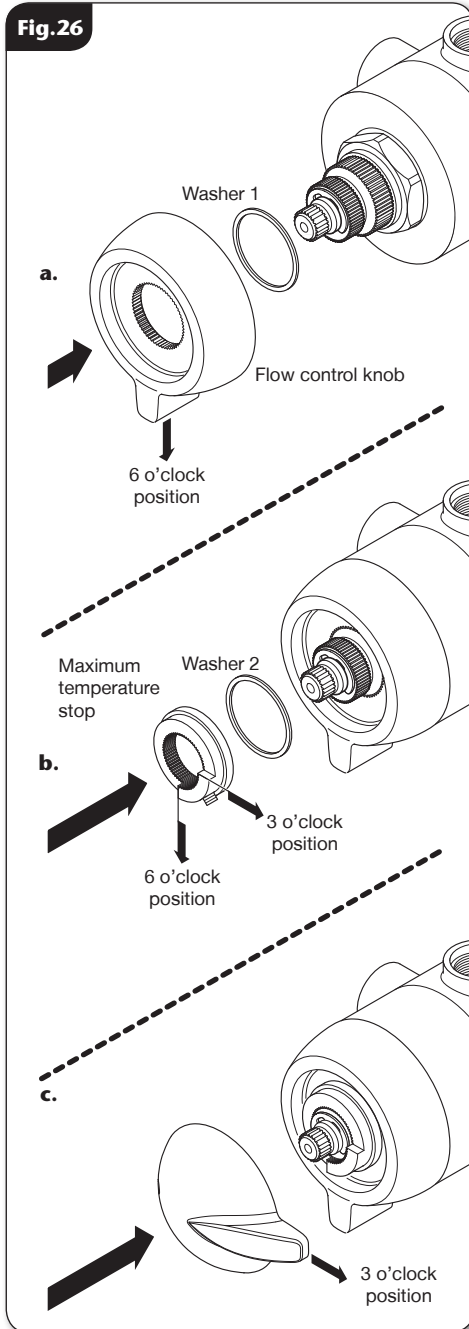

Fig.26



COMMISSIONING

Temporarily fit the controls (**fig.26**) and perform the commissioning procedure.

- Start the water flow by rotating the flow control.
- Make sure that both the hot and cold water supplies are fully open and at (or near to) their appropriate temperature and pressures, and are within the requirements stated on **Pages 2 & 16**.
- Make sure the temperature control is at the maximum temperature setting.
- Allow the shower to run at the maximum temperature setting until the water temperature has stabilised. Rotate the temperature control until your desired maximum showering temperature is reached.
- The mixer has a temperature stop to prevent accidental rotation to higher temperatures. This is adjustable to provide a maximum temperature of 35°C - 45°C and should be checked on site to guarantee user safety.

Temperature adjustment range

The mixed water temperature can be adjusted from cold through to a top limit (which can be pre-set during installation – factory set at approximately 38°C) with full anti-scald protection throughout the range.

Recommended outlet temperatures

The BuildCert TMV scheme recommends the following set maximum mixed water outlet temperatures for use in all premises:

- 44°C - for bath fill but see notes below.
- 41°C - for showers.
- 41°C - for washbasins.
- 38°C - for bidets.

The mixed water temperatures must never exceed **46°C** at terminal fitting.

The British Burns Association recommends **37** to **37.5°C** as a comfortable bathing temperature for children. In premises covered by the Care Standards Act 2000, the maximum mixed water outlet temperature is **43°C**.

FITTING THE CONTROLS

The mixer valve is supplied without the controls fitted. Once a comfortable showering temperature has been established fit them as shown in **(fig.26)**.

IMPORTANT: DO NOT over tighten fitting screws.

- **(fig.26-a)** Fit washer A and then the flow control lever so that it is in the 6 o'clock position.
- **(fig.26-b)** Fit the washer B and then the maximum temperature stop.

The end of the thin outer raised edge should be around the 6 o'clock position with the grub screw fitting positioned on the left hand side. Once the maximum temperature stop is in place, tighten the retaining grub screw.

- **(fig.26-c)** Fit the temperature control, making sure the maximum temperature stop pin is as close to the flat edge of the temperature stop as possible (*the lever should be at the 3 o'clock position, as a guide*).
- Secure the temperature knob in place with the retaining screw and fit the end trim.

ADJUSTING THE MAXIMUM TEMPERATURE SETTING

The mixer valve is supplied with the temperature factory set to 38°C (this can be adjusted during installation).

- To adjust the maximum temperature setting remove the temperature control.
- Allow the water to run until the temperature has stabilised, adjust the temperature control spindle by hand **(fig.27)**.
- When the showering temperature is satisfactory turn off the shower.
- Refit the temperature control as shown in **(fig.26)**.

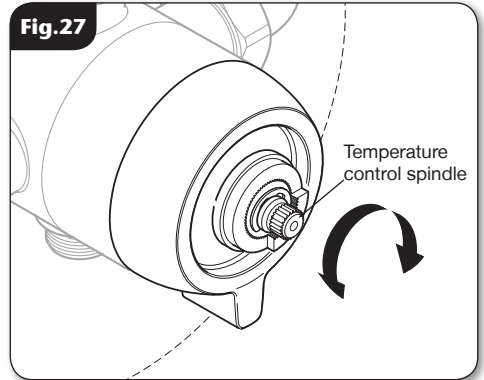
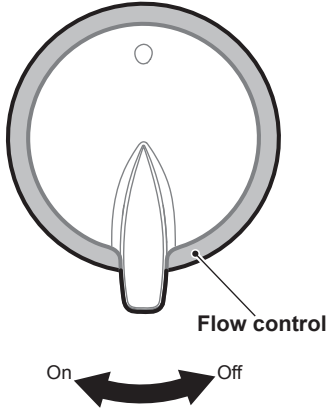

Fig.28



OPERATING THE SHOWER

- To start the shower, turn the On/Off flow control fully clockwise for maximum flow (**fig.28**).
- To stop the shower, turn the On/Off flow control fully anti-clockwise (**fig.28**).
- To adjust the showering temperature rotate the temperature control – clockwise for cooler and anti-clockwise for hotter (**fig.29**).

CAUTION: Exposed metal and chromed surfaces may become hot during use.

Fig.29

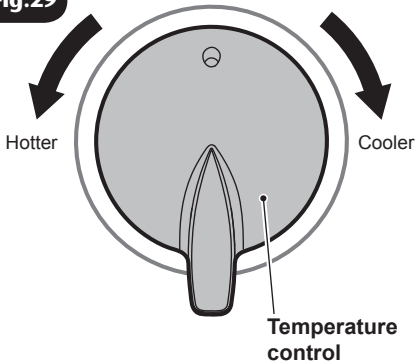

DIMENSIONS

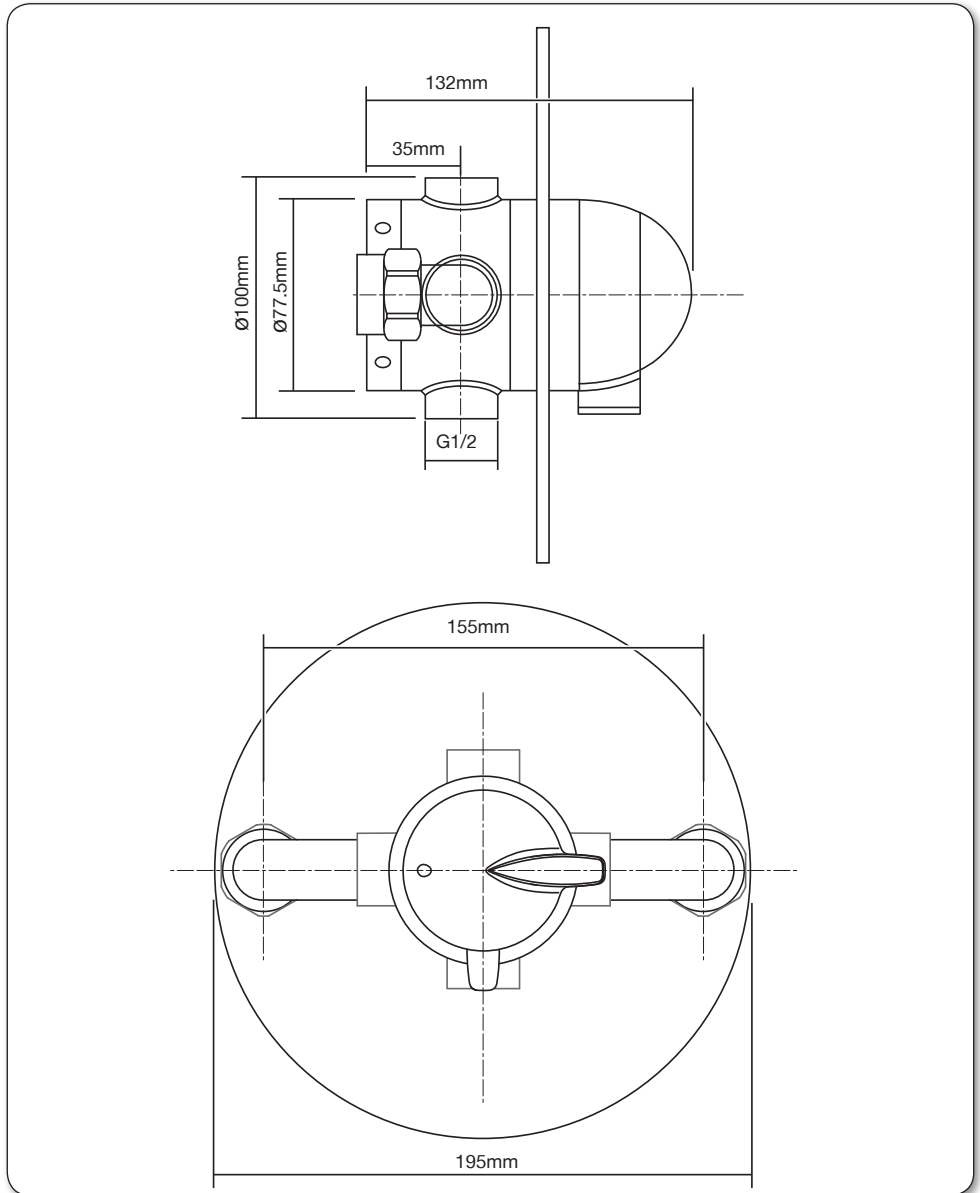

All dimensions listed in this fitting book regarding the product and installation are approximate.

SPARE PARTS

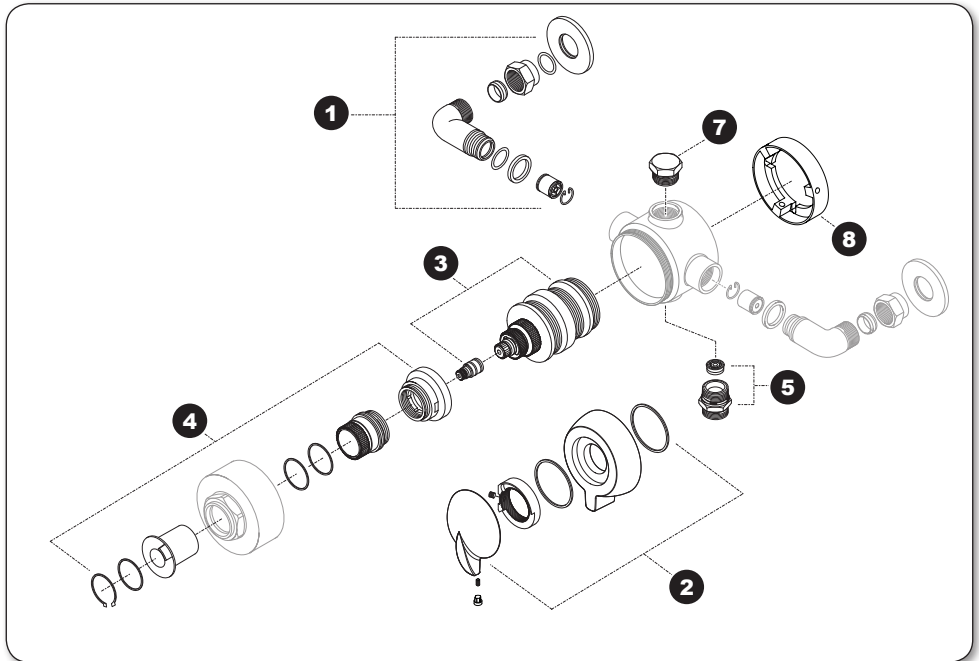

Ref.	Description	Part No.	Ref.	Description	Part No.
1.	Inlet elbow assembly	83315680	7.	Blanking plug	83315700
2.	Handle assembly.....	86004430	8.	Mounting plate.....	83315680
3.	Temperature cartridge	83315660	-	Bulkhead	85500230
4.	Flow control assembly	83315670	-	Bulkhead connector	7032915
5.	Outlet adapter	83315710	-	Cover plate.....	86004440
6.	Flow regulators are available at the following ratings (8.0L/M supplied):				
	Flow regulator 3.0L/M.....	22010310			
	Flow regulator 4.0L/M.....	22011740			
	Flow regulator 5.0L/M.....	22011750			
	Flow regulator 6.0L/M.....	22011760			
	Flow regulator 7.0L/M.....	22011610			
	Flow regulator 8.0L/M.....	22011280			

Concentric Thermostatic Mixer Shower

APPROVALS

This mixer valve has been designed to comply with the requirements of: **BS EN 1111**
BS EN 1287
WRAS

FLOW CHART

Flow Rate (l/m)	6.0	8.6	11.6	13.9	15.8	22.9	33.3	40.8	47.5	53.4
Pressure (bar)	0.1	0.2	0.3	0.4	0.5	1.0	2.0	3.0	4.0	5.0

Conditions for test

Inlet temperatures comply with EN1111 requirements

Outlet temperature 38°C

Flow Control Fully Open

Open Outlet - No hose or showerhead connected

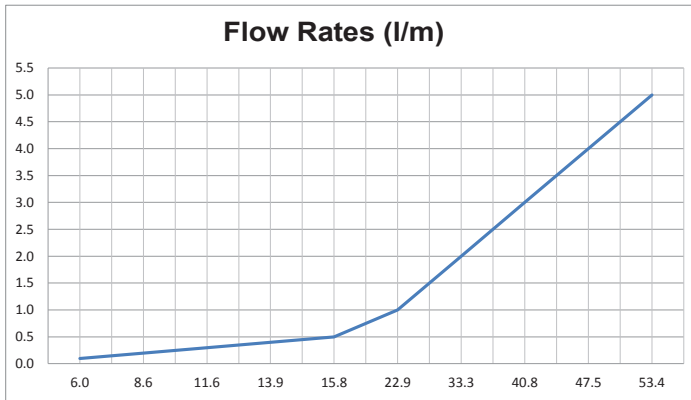

MAINTENANCE

The following maintenance procedure must be carried out for commercial and health care premises, but is not necessarily required for domestic installations.

Maintenance of the unit is required to give continued performance after installation and that it continues to provide scald prevention.

Note: *A thermostatic mixing valve in need of maintenance can be undetectable in normal use and only becomes apparent when a disruption occurs in the hot or cold water supply temperatures or pressures.*

The frequency of routine maintenance of the internal of the valve will depend mainly on the water supply condition. Experience of local conditions will dictate the intervals for inspection and in-service testing. Guidance has been given below which can be adjusted for local requirements.

- a) Initially check the filters for debris once every three months and clean if necessary.
- b) Perform a thermal shut off test every three months, and check the maximum temperature setting. See the 'Commissioning' section for the details of this test and readjustment of the maximum temperature setting if required.
- c) If the maximum water temperature varies by more than 2°C from the commissioned setting then carry out the following checks
 - Check the isolating valves are fully open.
 - Check the internal surface for scaling.

If the body requires descaling then it should be removed from the pipework to carry this work out (all rubber parts **MUST** be removed before descaling).

- Check the function of the non-return valves.

The non-return valves (NRVs) prevent cross-flow between hot and cold supplies under unequal pressure conditions. They are designed for long life with no maintenance.

If these checks do not highlight the reason for the temperature variation, then internal components will require replacement - *please see the spare parts list.*

Cleaning

It is recommended that all products are cleaned using warm, soapy water.

Do not use abrasive or aggressive chemical cleaning products as this may affect the product surface finish and invalidate your guarantee.

Cleaning the filters (fig.A)

It is advised that this should be carried out by a qualified person.

- Turn off the water supplies before starting.
- To gain access to the filters remove the unit from the inlet fittings.
- Remove Hot and Cold elbows.
- Remove the retaining clips, NRV's and filters.
- Wash the filters thoroughly under running water, use a suitable brush to remove all debris.
- Reassemble and fit in reverse order.

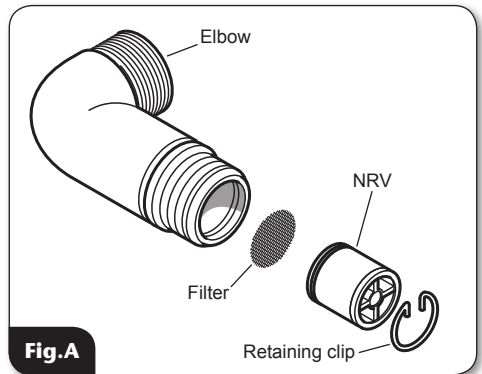

Disinfection

Where chlorine is used for the disinfection of water systems all relevant guidelines and approved codes of practice must be strictly followed. Failure to comply with the relevant guidelines and approved codes of practice may invalidate your guarantee.

WARNING!

DO NOT use 'powerful' abrasive or solvent cleaning fluids when cleaning the shower as they may damage the fittings.

FAULT FINDING

The following can be carried out by a competent person

Problem/Symptom	Cause	Action/Cure
1 Water too hot.	1.1 Temperature control incorrectly commissioned.	1.1.1 Refer to commissioning section.
	1.2 Not enough cold water flowing through shower.	1.2.1 Reposition temperature control knob
	1.3 Increase in the ambient cold water temperature.	1.3.1 Reposition temperature control knob.
	1.4 Cold water supply blocked.	1.4.1 Turn off the shower and consult a competent plumber or contact Customer Service.
	1.5 High volume of cold water drawn off elsewhere.	1.5.1 Reduce the simultaneous demand from the supply.
2 Water too cold.	2.1 Temperature control incorrectly commissioned.	2.1.1 Refer to 'commissioning' section.
	2.2 Not enough hot water flowing through shower.	2.2.1 Reposition temperature control knob
	2.3 Decrease in the ambient cold water temperature.	2.3.1 Reposition temperature control knob
	2.4 Insufficient hot water supplies from the heating system.	2.4.1 Make sure heating appliance is set to maximum or has sufficient stored hot water. 2.4.2 Make sure heating appliance is igniting by trying a hot water tap elsewhere.
	2.5 Hot water supply blocked or restricted.	2.5.1 Turn off shower and consult a competent plumber or contact Customer Service.
	2.6 Flow regulator not fitted (HP systems only).	2.6.1 Fit the supplied flow regulator (<i>Page 9 or 15</i>).
3 High water flow and/or poor performance on a mains fed system.	3.1 Flow regulators not fitted.	3.1.1 Fit flow regulator (<i>Page 9 or 15</i>).

FAULT FINDING

Problem/Symptom	Cause	Action/Cure
4 Water does not flow or shower pattern collapses when another outlet is turned on.	4.1 Water supplies cut off.	4.1.1 Check water elsewhere in house and if necessary contact local water company.
	4.2 Shower unit blocked.	4.2.1 Inspect the inlet filters. Clean if necessary.
	4.3 Blockage in pipework.	4.3.1 Turn off the shower and consult a suitably competent plumber.
	4.4 Showerhead blocked.	4.4.1 Clean showerhead.
	4.5 System not capable of supplying multiple outlets at the same time.	4.5.1 Reduce the simultaneous demand. 4.5.2 Make sure stop/service valves are fully open. 4.5.3 Check if sufficient water pressure.

The following is recommended for a professional qualified installer only

5 Water too cold.	5.1 Running pressure in excess of maximum recommended.	5.1.1 Fit a pressure reducing valve.
6 Shower controls noisy while in use.	6.1 Running pressure in excess of maximum recommended.	6.1.1 Fit a pressure reducing valve.
7 Shower will not shut off.	7.1 Flow control cartridge worn.	7.1.1 Renew flow control cartridge.

UK SERVICE POLICY

In the event of a product fault or complaint occurring, the following procedure should be followed:

1. Telephone Customer Service on **0844 980 0750** having available, your details including post code, the model number and power rating of the product, together with the date of purchase and, where applicable, details of the particular fault.
2. If required, the Customer Service Advisor will arrange for a qualified engineer to call.
3. All products attended to by a Triton service engineer must be installed in full accordance with the Triton installation guide applicable to the product. *(Every product pack contains an installation guide, however, they can also be bought via our Customer Service Spares Department).*
4. Our engineer will require local parking and if a permit is required this must be available to the engineer on arrival at the call.
5. It is essential that you or an appointed representative (*who must be over 18 years of age*) is present for the duration of the service engineer's visit. If the product is in guarantee you must produce proof of purchase.
6. Where a call under the terms of guarantee has been booked and the failure is not product related (*i.e. scaling and furring, incorrect water pressure, pressure relief device operation or electrical/plumbing installation fault*) a charge will be made. A charge will also be issued if nobody is at home when the service engineer calls or adequate parking/permit is not available.
7. If the product is no longer covered by the guarantee an up front fixed fee will be charged before the site visit.
8. Should proof of purchase not be available on an "in-guarantee" call, or should the service engineer find that the product is no longer under guarantee, the engineer will charge the same fixed price and the customer will be expected to pay the engineer before he leaves. If payment is not made on the day an administration charge will be added to the fixed charge.
9. If a debt is outstanding from a previous visit, or from any other Triton purchase. Triton reserves the right to withhold service until the debt has been settled.
10. Triton takes the health, safety and wellbeing of its employees very seriously and expects customers to treat all staff members with respect. Should any employee feel threatened or receive abuse, either verbally or physically, Triton reserves the right to withhold service and will support the employee with a legal prosecution.

Replacement Parts Policy

Availability: It is the policy of the manufacturer to maintain parts availability for the duration of production and a period of five years thereafter, in accordance with industry standards.

Spare parts are available via our website, www.tritonshowers.co.uk, or by telephoning Triton Customer Service Spares Department. Payment should be made by credit/debit card (excluding American Express or Diners Card). Payment can also be made by pre-payment of a pro forma invoice by cheque or money order.

Telephone orders are based on information given during of the call.

Before contacting Triton, please verify your requirements using the information contained in the supplied user guide. Triton cannot accept liability for incorrect part identification.

TRITON STANDARD GUARANTEE

With the exception of accessories, Triton guarantee the product against all manufacturing defects for a period of **5 years** (for domestic use only) from the date of purchase, provided that it has been installed by a competent person in full accordance with the fitting instructions.

All accessories such as shower heads, hoses and riser rails carry a **1 year** parts only guarantee against manufacturing defects.

Any part found to be defective during this guarantee period we undertake to repair or replace at our option without charge so long as it has been properly maintained and operated in accordance with the operating instructions, and has not been subject to misuse or damage. This product must not be taken apart, modified or repaired except by a person authorised by Triton. This guarantee applies only to products installed within the United Kingdom and does not apply to products used commercially. This guarantee does not affect your statutory rights.

What is not covered:

1. Breakdown due to: *a)* use other than domestic use by you or your resident family; *b)* wilful act or neglect; *c)* any malfunction resulting from the incorrect use or quality of electricity, gas or water or incorrect setting of controls; *d)* failure to install in accordance with this installation guide
2. Claims for missing parts once the product has been installed.
3. Repair costs for damage caused by foreign objects or substances.
4. Total loss of the product due to non-availability of parts.
5. Compensation for loss of use of the product or consequential loss of any kind.
6. Call out charges where no fault has been found with the appliance.
7. The cost of repair or replacement of pressure relief devices, showerheads, hoses, riser rails and/or wall brackets, isolating switches, electrical cable, fuses and/or circuit breakers or any other accessories installed at the same time.
8. The cost of routine maintenance, adjustments, overhaul modifications or loss or damage arising therefrom, including the cost of repairing damage, breakdown, malfunction caused by corrosion, furring,
9. Call out charges where the water supply cannot be isolated, this includes consequential losses arising from unserviceable supply valves.

For the latest Terms & Conditions, please see:
www.tritonshowers.co.uk

Triton Showers
Triton Road
Nuneaton
Warwickshire CV11 4NR

Triton is a division of Norcros Group (Holdings) Limited

Customer Service: ☎ **0844 980 0750**

Trade Installer Hotline: ☎ **0844 980 0730**

Fax: **0844 980 0744**

www.tritonshowers.co.uk

E-mail: serviceenquiries@tritonshowers.co.uk