

BRISTAN

Installation Instructions and User Guide

Joy ThermoSafe™ Electric
Shower

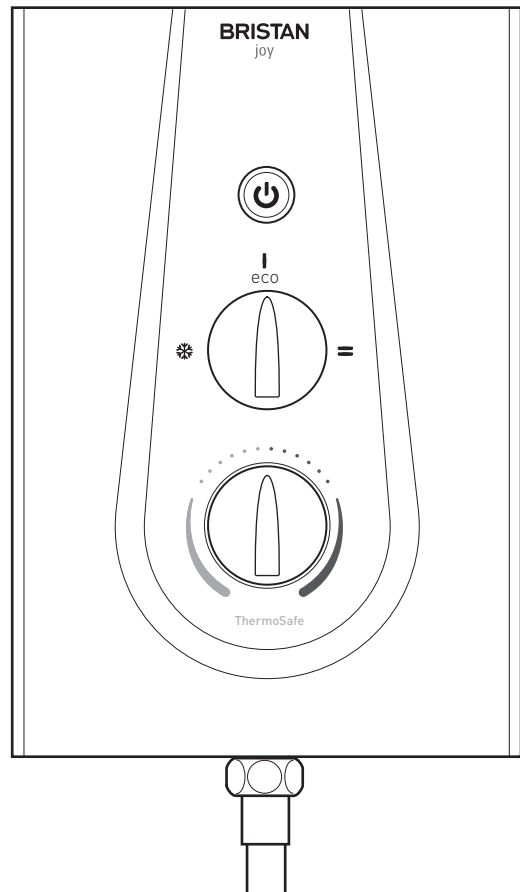

Please keep this booklet for future reference.

Installer, when you have read these instructions
please ensure you leave them with the user.

Contents

Welcome to your new Bristan electric shower.

Featuring a contemporary design with lots of fun features, Bristan's electric shower collection has been designed to be enjoyable to fit and to use.

It has also been designed and tested in the UK to all of the relevant British Standards.

These instructions contain all of the necessary installation and operating information, so please read them thoroughly and keep for future reference.

These instructions are for your guidance to a safe and successful installation which we recommend is carried out by a suitably qualified person and must conform with current I.E.E Wiring Regulations (BS7671) and Building Regulations (Part P and Part G).

Note: An Installation Template is provided in the centre pages of this booklet.

Important Safety Information.....	3
Product Features.....	4
Electrical Requirements	5-6
Water Requirements	7
Fixing Your Shower to the Wall	8
Plumbing Connections.....	9-11
Electrical Connections	12-14
Fitting Your Riser Rail to the Wall.....	15
Commissioning - Testing the System.....	16
Operating the Shower	17-18
Maintenance	18-19
Troubleshooting.....	19
Guarantee	20
Service Policy.....	20
Spare Parts.....	21-23

Recommended Usage			
Domestic	✓	Heavy Commercial	✗
Light Commercial	✓	Health Care	✗

Important Safety Information

- Please read these instructions thoroughly and retain for future use.
- All products manufactured and supplied by Bristan are safe provided they are installed, used correctly and receive regular maintenance in accordance with these instructions.
- **If you are in any doubt about your ability to install this product safely you must employ the services of an experienced qualified plumber/electrically qualified person.**
- **⚠ Warning:** Do not operate the shower unit if you suspect it is frozen. Do not site the shower unit where it might be subjected to freezing conditions.
- Do not install this shower unit in a room/environment without adequate ventilation or an extractor fitted. This is required to prevent condensation forming within the unit.
- Do not operate the shower unit if the showerhead or spray hose has been damaged or is blocked.
- Do not block the flow of water from the showerhead, by placing it (smothering it) on your hand or any other part of your body or foreign object.
- Do not operate the shower if the water stops flowing during use or if the water is leaking from the shower unit itself. Turn off at the mains electrical supply and refer to the Troubleshooting section (see page 19) or contact Bristan Customer Services (see page 20).
- Do not crush or kink the shower hose, this could damage the hose, cause leaks and activate the pressure relief device (PRD).

General Safety

- Always switch off the power at the consumer unit and isolate the electrical supply before making any electrical connections or if you have to remove the cover of an installed unit.
- The unit **must** be mounted on the finished wall surface (usually tiled). Under no circumstances must you tile up to or seal around the unit as this may prevent air circulating and condensation escaping.
- This shower unit **must** not be modified* in any way as this will invalidate the guarantee.
* Except for top left pipe entry (see page 9) where the product has been designed to be modified by the installer.
- You **must not** fit a “water saving” handset (whereby the flow of water can be restricted or turned off) to the shower, otherwise this can result in scalding and/or unit failure.



Intertek

BEAB (British Electrotechnical Approvals Board) approval of safety.

Need help? Give us a call on **0844 701 6273** and speak to one of our trained advisors.

Product Features

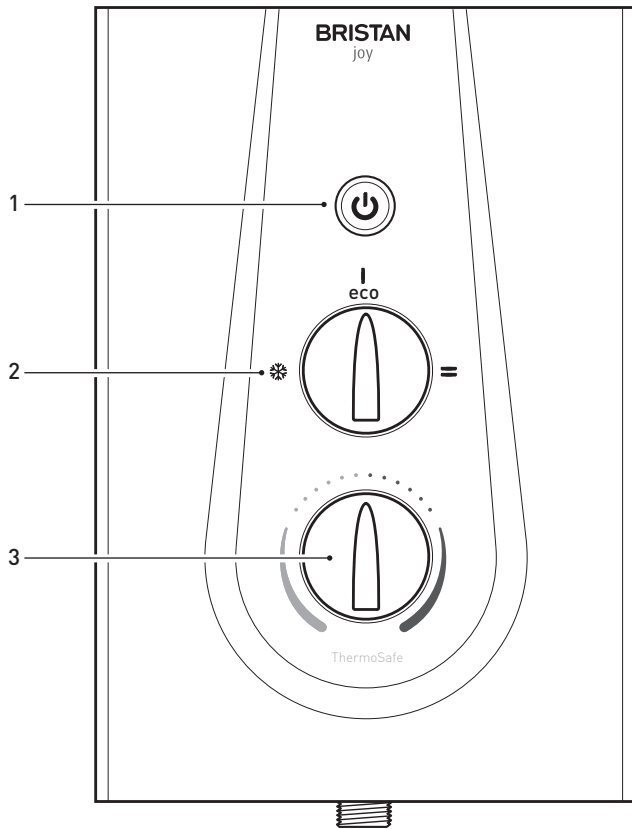

1. Push Button STOP/START Button

Press once to start the shower, press once again to stop the shower.

2. Power Control

Adjustable power settings:
Cold (❄️), Medium (eco 🌿) and High (⚡️).

3. Temperature Control

Adjustable temperature control.

Temperature Control Device

The Temperature Control Device will activate when the temperature is set too high and the water inside the water heater gets too hot. The Temperature Control Device will switch off the power to the heating elements. Once the unit cools down to a safe temperature the elements will come on again and reheat the water within the water heater and the whole cycle will repeat itself until the temperature is manually reduced.

Phased Shut Down

When the shower is turned off, water will continue to flow for a short period of time while the heater cools down to approximately 30 before automatically turning off.

ThermoSafe™ Technology

ThermoSafe™ technology regulates the output water to minimise high/dangerous output temperatures for a safer showering experience.

Electrical Requirements

⚠ Warning: This appliance MUST be earthed!

Rating at 240V	Rating at 230V
8.5kW	7.8kW
9.5kW	8.7kW

The Electrical Installation and Circuit Protection of this shower must comply with current I.E.E Wiring Regulations (BS 7671) and Building Regulations (Part P). We recommend that this product is installed by a qualified electrician prior to use. The following notes are for guidance only.

Important: You **must** switch off the power at the consumer unit, isolate the electrical circuit and verify the earth before making any electrical connections.

The shower must only be connected to a 230-240V AC supply. The electrical rating of your shower is on the pack or on the rating plate label.

The shower must be connected to its own independent electrical supply. It **must not** be connected to a ring main, spur, power socket, or lighting circuit.

If you don't have a spare fuse way or the rating at the main fuse box is below 80A, you should seek advice from an electrician and may need a new consumer unit - specifically for the shower.

A separate and permanently connected cable must be taken from the consumer unit directly to the shower via a 45 Amp double pole switch with a minimum contact separation gap of 3mm in live (L) and neutral (N) poles.

The isolating switch can be a ceiling mounted pull cord switch within the bathroom or wall mounted in an adjacent room. The power switch must be easily accessible and identifiable as the supply to the shower.

Note: Voltage drop in the supply to the premises, due to heavy local demand, will affect the performance of your shower. To gain the optimum power possible from this shower unit try to find the shortest possible route from the consumer unit to the shower to run your cable.

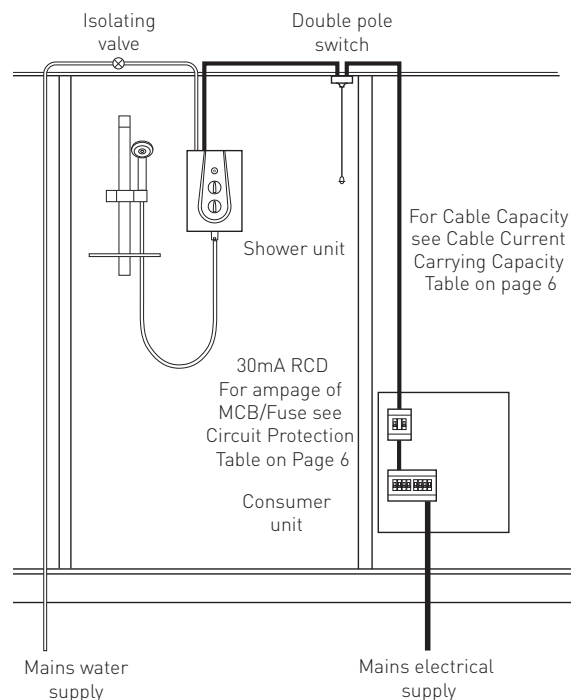

continued on next page

Electrical Requirements cont.

It is a requirement that a residual current device (RCD) formerly known as an earth leakage circuit breaker (ELCB) with a tripping current of 30mA, is incorporated in the circuit. This may be part of the existing consumer unit or a separate unit.

For close circuit protection DO NOT use a rewirable fuse. Instead use a suitably rated Miniature Circuit Breaker (MCB) or Cartridge Fuse.

Please refer to the Circuit Protection Table.

Circuit Protection Table		
	Circuit Protection Device	
Unit Rating (@ 240V)	MCB	Cartridge Fuse
8.5kW	40A	45A
9.5kW	40/45A	45A

The current carrying capacity of the cable must be at least that of the shower Circuit Protection Device.

Please refer to the Cable Current Carrying Capacity Table.

Cable Current Carrying Capacity Table (for Twin and Earth PVC Insulated Cable)		
Current Carrying Capacity		
In an insulated wall	In conduit or trunking	Clipped direct or buried in a non insulated wall
6mm ²	6mm ²	6mm ²
32A	38A	46A

Note: Cable selection is dependant on derating factors

On installation of the appliance the impedance measurement of the Neutral and Earth back to the supply source is to be less than 1.0 Ohms. This is in line with the general installation requirements of the UK Network and will generally present no problem within the UK Network.

In domestic installations you must ensure that the electrical supply and existing fuse board are adequately rated.

Do not turn on the electrical supply until the plumbing has been completed and the shower cover re-fitted.

Water Requirements

This fitting needs to be installed in accordance with the following Installation Requirements and Notes (IRN) to ensure they meet the requirements of the Water Supply (Water Fittings) Regulations 1999 and the Scottish Byelaws 2004.

The fitting shall be installed so that its outlet discharges above the spill-over level of any fixed appliance as indicated on the illustration below.

For backflow protection in premises or installations up to, and including Fluid Category 3 and 5.

The vertical distance of the outlet above the spill-over level shall be not less than 20mm or twice the diameter of the inlet pipe to the fitting, whichever is the greater. If the fitting cannot be installed as indicated it shall be installed with a backflow prevention arrangement suitable for the Fluid Category.

If the shower is to be installed in a hard water area, we recommend that an in-line scale inhibitor is fitted which will prolong the life of the shower. Please refer to your supplier for advice.

⚠ Warning: The shower must not be installed in an area subject to freezing conditions. Do not use if you suspect the shower is frozen, this will damage the shower unit.

The shower must be connected to a mains water supply only with a minimum working inlet pressure of 0.07MPa (0.7bar) at a minimum flow rate of 8 litres per minute. The maximum static inlet pressure must not exceed 1.0MPa (10bar).

A minimum working inlet pressure of 0.1MPa (1bar) at a minimum flow rate of 8 litres per minute is recommended for full ThermoSafe™ performance.

If it is intended to operate the shower at pressures above the maximum stated, a suitable pressure reducing valve (PRV) should be used.

Water regulations stipulate that the showerhead be 'constrained by a fixed or sliding attachment (hose retainer) so that it can only discharge water at a point not less than 20mm above the spill over level of the bath or shower tray or other fixed appliance'.

If a showerhead can sit within a bath, basin or shower tray, you must fit a double check valve in the supply pipe work to prevent back siphonage. If the showerhead can sit within a WC then the air gap should be a type AUK3 not less than 20mm or twice the diameter of the inlet pipe to the fitting, whichever is the greater.

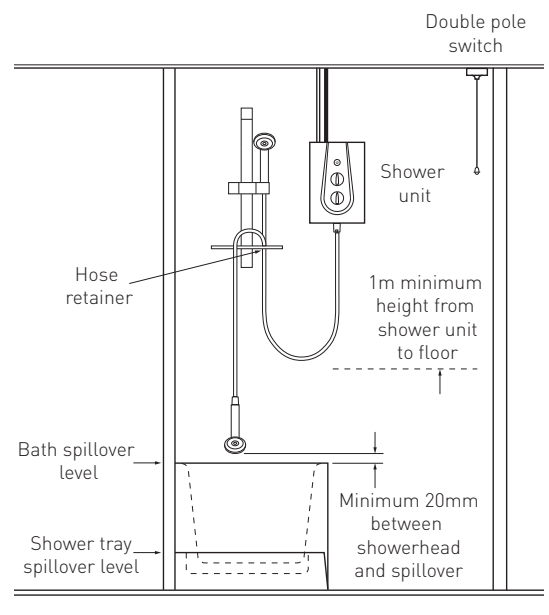

Fixing Your Shower to the Wall

Warning: Please check for any hidden pipes and cables before drilling holes in the wall.

Remove the 4 cover retaining screws and lift off the cover.

Do not try to remove the control knobs from the cover. They are an integral part of the cover and must not be removed.

If you are fitting the unit to a partition wall or a wall of particularly friable (crumbly) substrate, you will need appropriate fixings for the wall type.

Select the position for the shower unit over a bath or shower tray using the installation template provided in the centre pages of this booklet.

Important: The shower unit must be fitted to a flat, waterproof surface. Under no circumstances should the shower unit be attached to a wall and then tiled up to the edges. The unit must be fixed on top of the wall surface.

Important: Use a spirit level to ensure the template is level.

Mark the 3 fixing points with a suitable pencil through the paper. Remove the template from the wall and drill the wall to suit the wall fixings to be used.

Tips:

A piece of insulation or masking tape positioned where holes are to be drilled and before marking out the exact position for the fixing holes will help stop the drill bit from wandering, particularly on a tiled surface.

When working near a basin, bath or shower insert plug or cover waste to prevent losing small parts.

Take care not to drop tools/equipment into basin, bath or shower during shower installation.

Note: The unit can be hung temporarily on the top screws to help with the positioning of the pipe work etc.

* The bottom screw should only be fitted during final installation.

Important: Under no circumstances should this shower unit be recessed (it must be fitted onto the finished wall surface) or tiled up to or sealed around the unit as this may prevent air circulating and any condensation escaping.

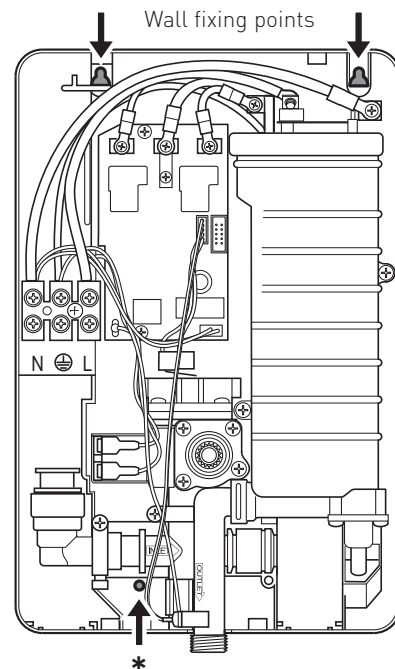
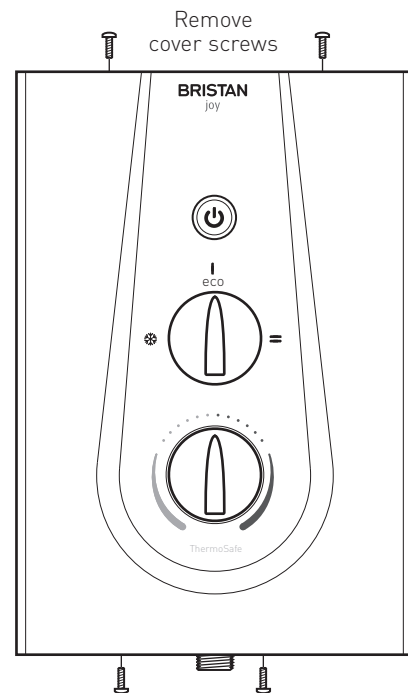

Plumbing Connections

Inlet Entry Options

Select the inlet option most suited to your situation.

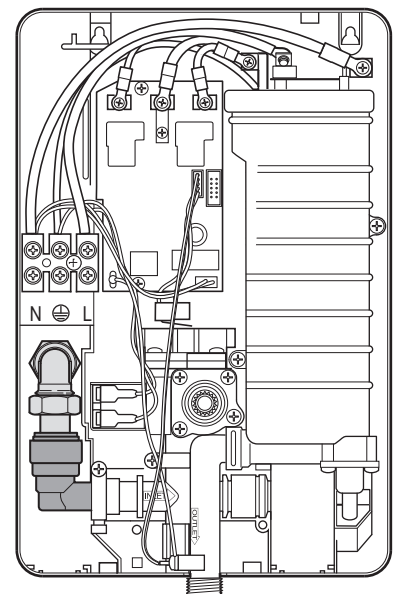
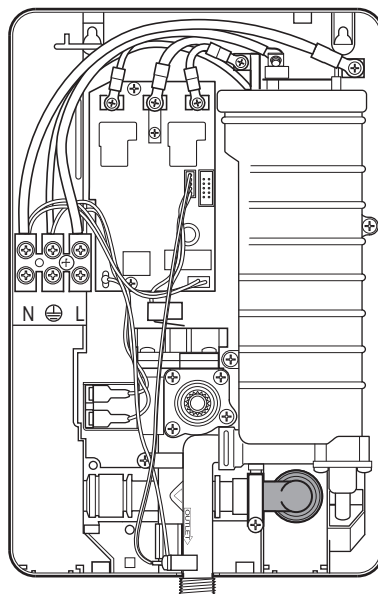
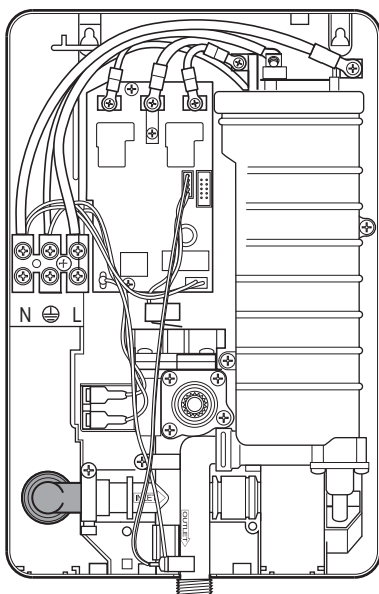
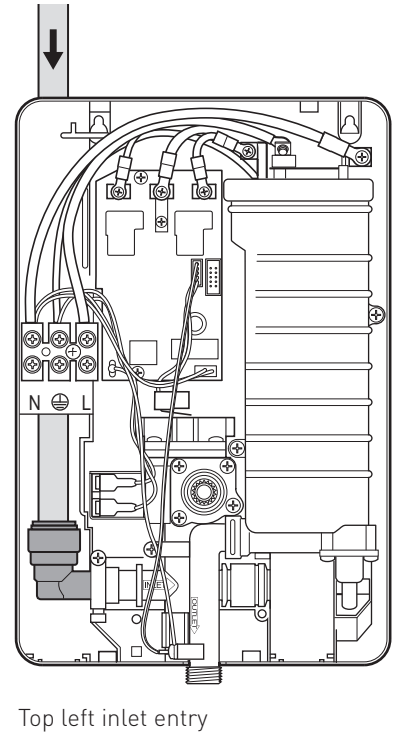
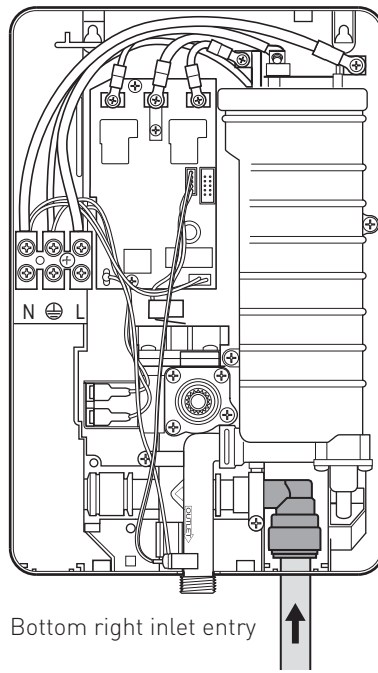
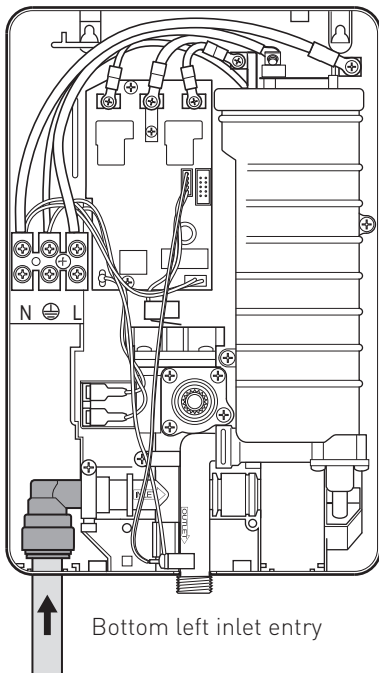

Plumbing Connections cont.

⚠ Warning: The outlet of the shower acts as a vent and must not be blocked, restricted or connected to any tap/ closure device other than the handset supplied.

Do not solder within 300mm of the shower unit or allow solder or flux to fall onto the casings.

Important: An additional independent stop valve complying with the current water regulations must be fitted in the mains water supply as a means of isolating the supply to the unit for servicing and/or maintenance work.

It is essential that all pipe work is flushed through to remove debris and swarf that could otherwise damage the unit. Once the pipe work has been flushed through, turn off the water supply at the stop valve.

Connect the mains water supply to the inlet port of the shower using 15mm copper pipe (BS EN1057) or 15mm plastic pipe (with insert).

Do not use stainless steel pipe work. If using chrome plated pipe ensure that the first 25mm of plating is carefully removed to allow push-fit fitting to grip the inlet pipe.

Inlet Entry Options

The pipe work can enter the shower unit from 6 different positions. Bottom left, Bottom right, Top left, Rear left, Rear right or Rear left - using an elbow (as shown on page 9).

To top or bottom left positions

The shower unit should come supplied with the inlet connection set for a bottom left position. To change it to a top left position: swivel the inlet connector elbow from facing downward to facing upward.

To bottom right position

Unfasten the screw (5) securing the inlet connector elbow clamp (6), remove the tab from the slot and keep until the inlet pipe is repositioned. Lift the outlet connection (7) up out of the way from its position at the bottom of the unit. Pull the inlet connector elbow towards you and over to the right hand side with the inlet entry point facing down. Refit the clamp tab (6) into the slot on the right, refasten the screw (5) and replace the outlet connection (7).

To rear entry positions

Swivel the inlet connector elbow to face a rear entry pipe connection. If the pipe work entry is from the rear, ensure that there is space left around the push-fit elbow for future servicing or alternatively access is possible from the rear. Bring the cold water pipe to the shower position and connect to the inlet elbow.

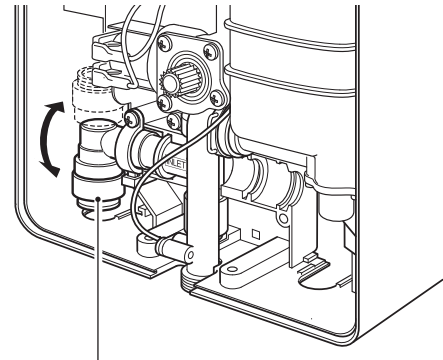

Inlet connector elbow (left side, up, down or rear)

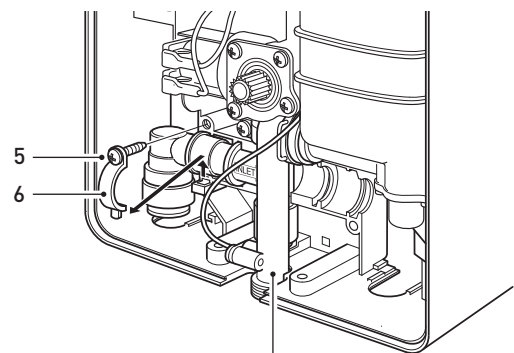

Outlet connection 7

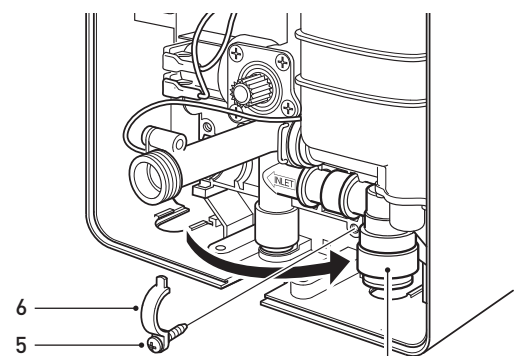
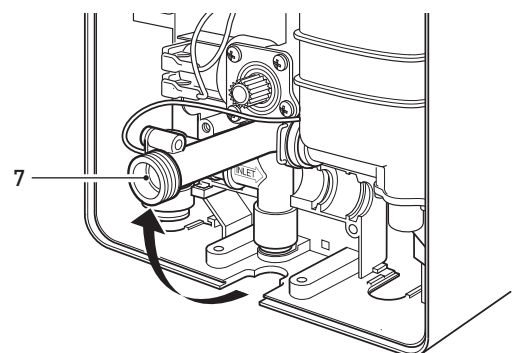

Inlet connector elbow (right side back or rear)

Plumbing Connections cont.

Hole Cover Fitting

Top left entry: Depending on your choice of cold-water entry direction, you may need to remove thin areas of plastic cover to facilitate pipe work entry down through the top left of the unit.

Bottom entry: Depending on your choice of cold-water entry direction, fit 'hole covers' to the pipe work slots at the bottom of the unit.

Note: The grey areas shown are tabs that can be removed to allow 6mm cable entry only.

Water Connection

The inlet pipe connection into the elbow is a self-seal push-fit type. All burrs and rough edges must be removed from the end of the pipe before connecting.

To release the pipe work from the push-fit type fitting, press and hold the collet against the elbow and pull the pipe out of the elbow.

Turn on the water supply and inspect for water leaks at the shower inlet. Once inspected-turn off the water supply.

Pressure Relief Device (PRD)

A pressure relief device is designed into this shower. The pressure relief device provides protection should an excessive build up of pressure occur within the shower unit. It is advisable to position the shower unit over a bath or shower tray in the unlikely event the device should discharge.

Do not use the shower with a damaged or kinked shower hose or blocked handset. This may trigger the PRD which will discharge through the vent in the bottom right hand corner (shown).

In the event of the PRD activating, water will be discharged from the vent. If this happens, switch off the electricity and water supplies to the shower and contact Customer Services (see page 19).

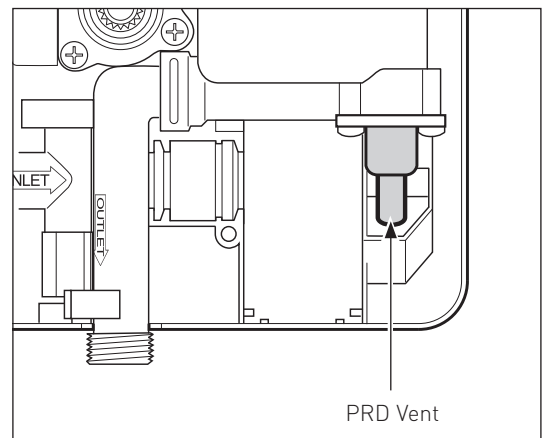
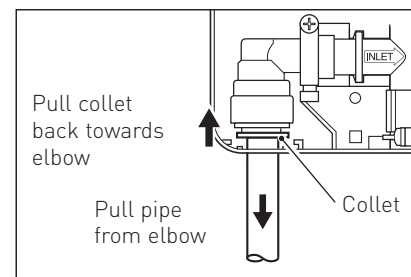
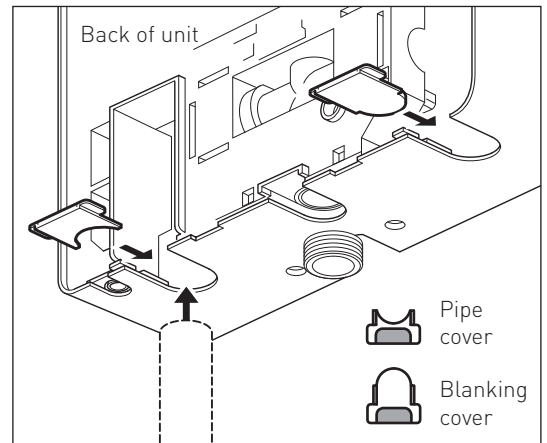

Electrical Connections

⚠ Warning: This appliance and all connecting metal pipe work must be earthed.

- Ensure that an earth continuity conductor is securely and permanently connected to all exposed metal parts of other services and appliances within the room where the shower is installed.
- All cables **must** conform to the relevant tables within the current I.E.E Wiring Regulations (BS 7671). The electrical supply cable must be either recessed or in a conduit/trunking as detailed in the current I.E.E Wiring Regulations (BS 7671). Refer to pages 5 and 6.

Electrical Connection Entry Point Options

Select the cable inlet option most suited to your situation.

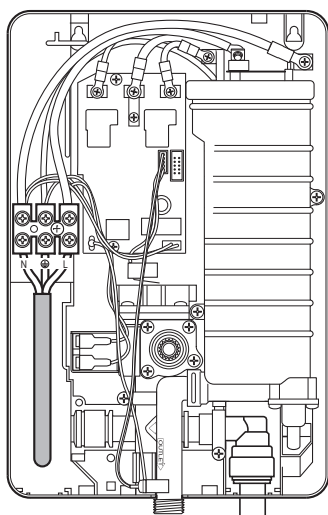

Rear bottom left cable entry

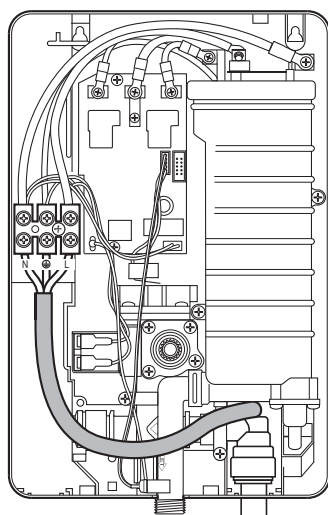

Rear bottom right cable entry

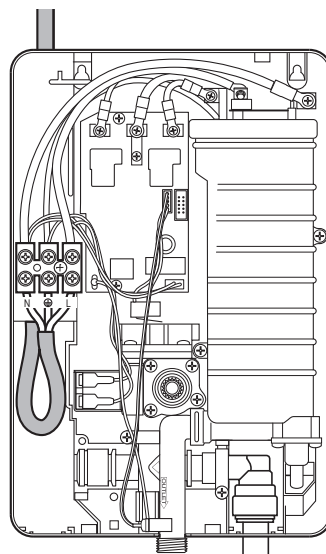

Top left cable entry

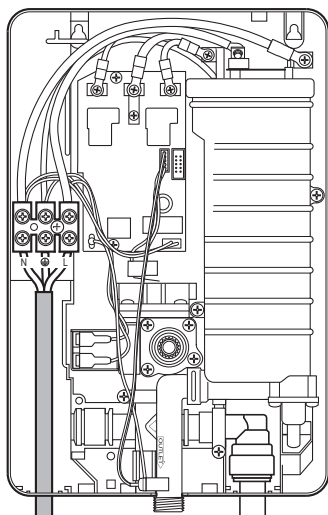

Bottom left * cable entry

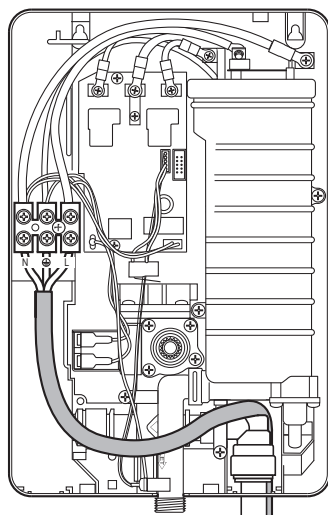

Bottom right * cable entry

Note: Depending on cable size and entry point used it may be necessary to strip back outer cable sheath sufficiently to allow cables to be directed to the terminal connection block within the unit.



Pipe cover



Blanking cover

***Note:** When feeding cable through bottom entry points remove highlighted grey tab on pipe/blanking cover if using 6mm cable.

For 10mm cable remove the pipe/blanking cover entirely.

continued on next page

Electrical Connections cont.

Electrical Connection Entry Point Options - continued

Alternatively, if preferred, it is possible to route the cable from the rear bottom right or bottom right positions as shown below by stripping the sheath back further.

Select the cable inlet option most suited to your situation.

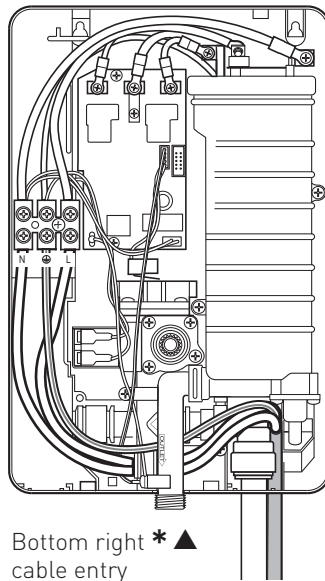
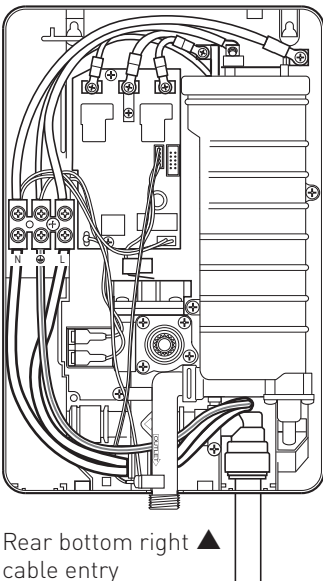

Note: Depending on cable size and entry point used it may be necessary to strip back outer cable sheath sufficiently to allow cables to be directed to the terminal connection block within the unit.



Pipe cover



Blanking cover

***Note:** When feeding cable through bottom entry points remove highlighted grey tab on pipe/blanking cover if using 6mm cable.

For 10mm cable remove the pipe/blanking cover entirely.

▲ **Note:** We recommend that the blue (neutral) and brown (live) cables are fed under the filter housing. Position the earth cable under the outlet on top of the filter housing.

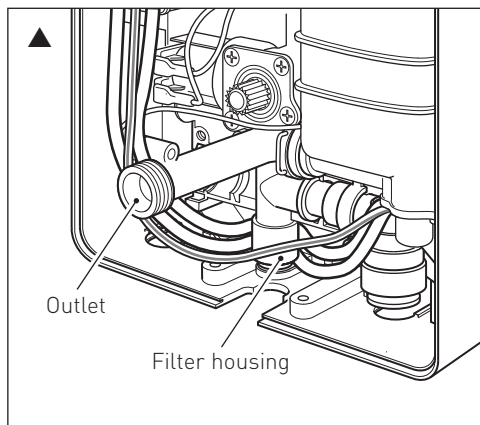

Electrical Connections cont.

Switch OFF the electricity supply at the consumer unit.

The power cable entry point is shown on the diagram.
Electrical connection to be made at the terminal block as follows:

Earth cable to the terminal marked with the Earth symbol 

Neutral cable to the terminal marked **N**

Live cable to the terminal marked **L**

Important: Terminals must be fully tightened onto the cables ensuring that no cable insulation is trapped under the screws. It must be metal to metal. Loose connections can result in the cables overheating, ensure all terminal screws are fully tightened.

The supply cable earth conductor must be sleeved. The supply cable must be secured by routing through conduit or in trunking or by being embedded in the wall in accordance with current I.E.E Regulations.

 **Warning:** Do not switch on power to the shower unit until the cover and the cable to connection (8) have been fully fitted.

- Plug in the cable from the cover to the connection (8) inside the unit.
- Set the power control knob (3) at 9 o'clock.
- Rotate the temperature control knob (4) fully anti-clockwise (full cold).
- Rotate the splined temperature control spindle (4a) fully anti-clockwise.
- Locate cover in position ensuring wiring is not trapped.
Note: slight adjustment of the knobs may be required to locate cover correctly.
- Secure using the 4 cover fixing screws supplied.

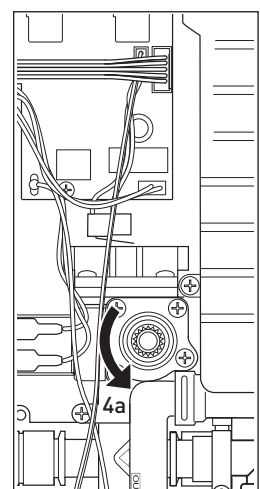
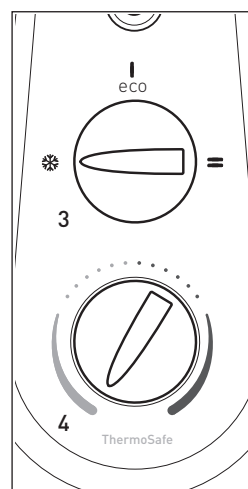
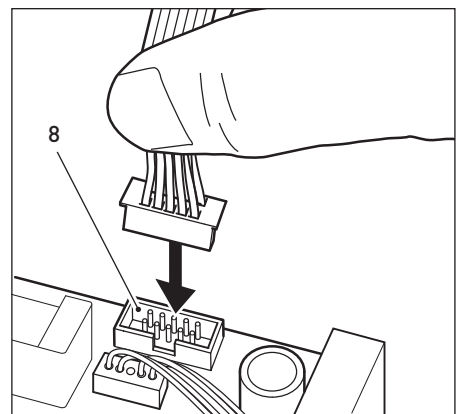
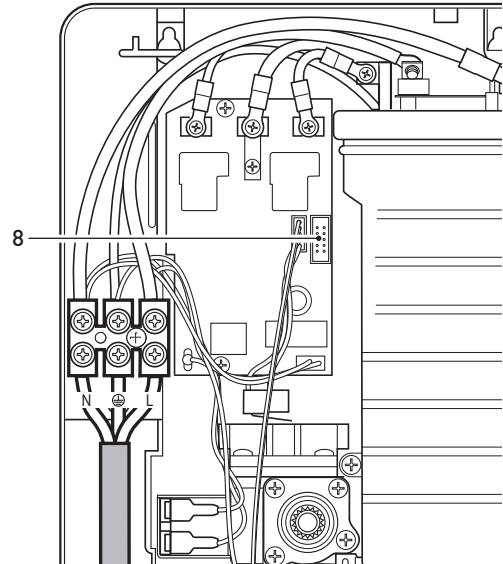

Fixing Your Riser Rail to the Wall

Fitting the Riser Rail

Before proceeding with fitting the rail, identify each of the items supplied using the illustration on the right.

The Slider should not be removed from the rail during fitting. The underside of the slider has a button to release the slider and allows the height to be adjusted.

Slide the soap dish onto the bottom end of the rail. Position a wall bracket onto each end of the rail, ensuring the hole through the top of the rail lines up with the hole in a wall bracket.

Position the rail on the wall, bearing in mind the different heights of people likely to use the shower and the length of the hose when connected to the shower and passed through the retaining hole in the soap dish. Mark the wall to indicate the upper fixing screw position.

Warning: Please check for any hidden pipes and cables before drilling holes in the wall.

Tips:

A piece of insulation or masking tape positioned where holes are to be drilled and before marking out the exact position for the fixing holes will help stop the drill bit from wandering, particularly on a tiled surface.

When working near a basin, bath or shower insert plug or cover waste to prevent losing small parts.

Take care not to drop tools/equipment into basin, bath or shower during shower installation.

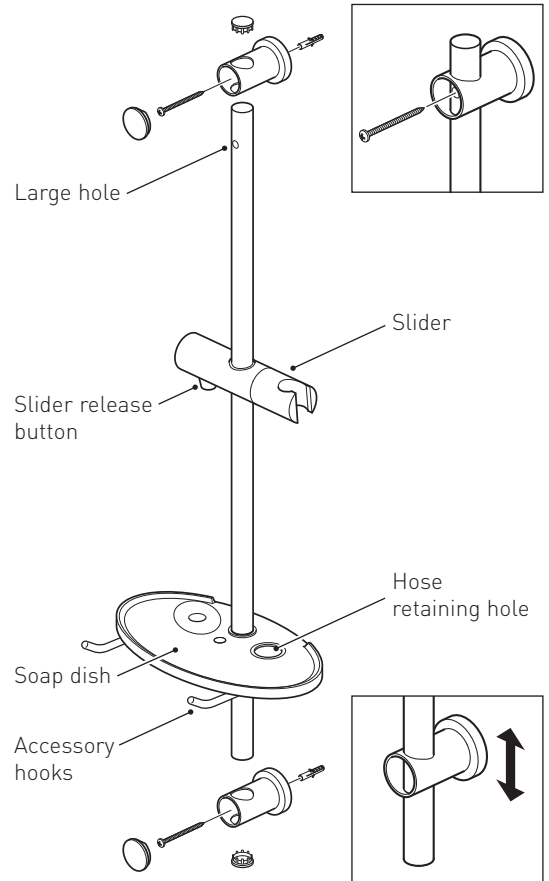

Drill the wall at the marked fixing position to suit the wall fixings to be used, loosely fix the rail (with the large hole on the side shown) and wall bracket. Check that the rail is hanging vertically using a spirit level.

Slide the lower wall bracket onto the rail and mark its required position onto the wall.

Note: The lower wall bracket does not fix to the riser tube and can be positioned along the riser tube so as to cover either an existing riser hole in the wall or over a tile joint.

Remove the lower bracket from the rail and unscrew the upper bracket from the wall. Mark and drill the lower wall bracket fixing position and fix the bracket to the wall. Slide the rail down through the lower wall bracket and reattach the upper bracket.

Check that the rail is perfectly vertical and tighten the upper fixing screw. Insert end caps into the wall brackets at both ends of the rail.

When fitting the hose, it should pass through the larger hole of the soap dish.

Note: The conical hose end and not the handset handle, fits into the slider. Ensure the washer is fitted between the hose and the handset handle. The slider moves more freely on the rail if gripped next to the rail, rather than at the handset.

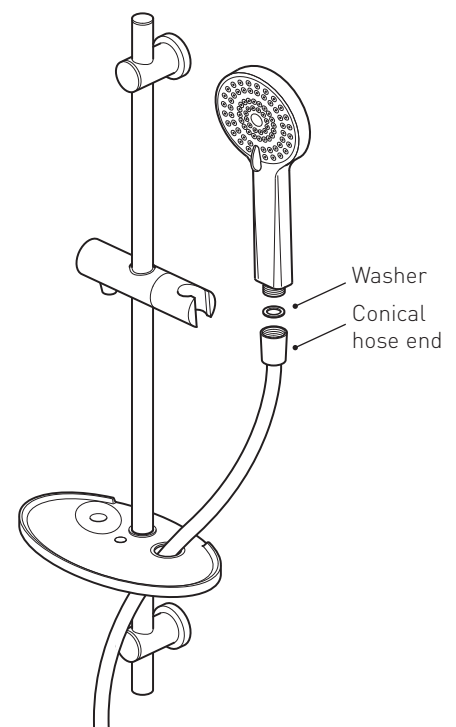

Commissioning - Testing the System

⚠ Warning: Before using the shower for the first time, it should receive a final flush through to remove any remaining debris that may be in the pipe work or hose and to ensure the heater unit contains water before the electrical elements are switched on.

Remove the showerhead from the hose and if not already attached, attach the hose to the outlet port and ensure that the outlet hose mesh filter is fitted. The power control knob (2) must be switched to the cold (❄ - 9 o'clock) position 'blue' (heating elements will not be on).

The temperature control knob (3) must be set fully clockwise to minimum flow. (This is to prevent the PRD activating when water is first turned on).

Turn on the water supply and inspect for water tightness.

Turn on the mains electrical supply to the shower.

Press the STOP/START button (1), wait approximately 30 seconds for the water to flow correctly. Once the water has flowed for a further 10 seconds, rotate the temperature control knob (3) from the fully clockwise position to the fully anti-clockwise position. Repeat this procedure several times until a continuous flow of water (with no air bubbles) is obtained from the shower hose.

Once you are satisfied that the system has been flushed through thoroughly, press the STOP/START button (1) to stop the flow.

Note: If the letters LP appear on the front panel just above the STOP/START button (1) this indicates too low a water supply pressure to the unit. Please switch off unit until water pressure increases before continuing to use the shower.

A digital display showing the letters 'LP' in a stylized font, indicating a low water pressure error.

Re-fit the showerhead to the hose, insert hose rubber washer to seal the joint; please ensure that the hose passes through the larger hole in the soap dish. The showerhead is attached to the riser rail by inserting the conical hose end into the movable slider.

Your shower is now ready for first use.

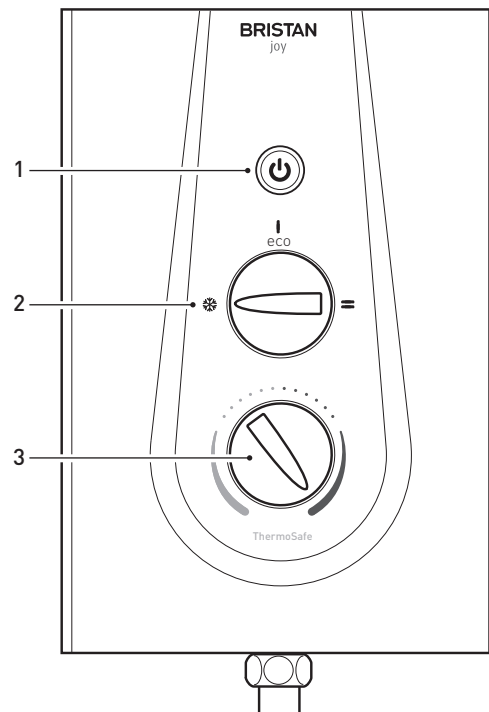

Operating the Shower

Please ensure the commissioning procedure has been carried out. If you did not fit this shower yourself and you are about to use it for the first time, check with the installer to ensure he or she has run the commissioning procedure as described on page 15.

To Start the Shower

Press the STOP/START button (1).

During periods of high ambient temperatures (e.g. hot summer days), it may be necessary to select a lower power setting in order to achieve your ideal shower temperature.

ThermoSafe™ Operation: When the shower is started, it will wait a short time for the shower outlet temperature to stabilise to establish the user's desired water temperature. The shower will then monitor the water temperature and adjust the heating power to compensate for rises in temperature, resulting in safe showering temperatures.

If the user adjusts either the Power Control or Temperature Control, the shower will again wait for the user's new desired temperature to stabilise. The shower will then resume its monitoring and compensation of water temperature.

To Stop the Shower

Press the STOP/START button (1).

Phased Shut Down: When the shower is turned off, water will continue to flow for a short period of time while the heater cools down. This ensures that the shower is ready for the next user. Do not use the isolation switch (pull cord) to stop the shower, use the STOP/START button (1).

It is always advisable to test the water temperature with your hand before stepping under the shower. Please note that there is always a delay of a few seconds between you selecting a temperature setting and the selected water temperature starting to flow.

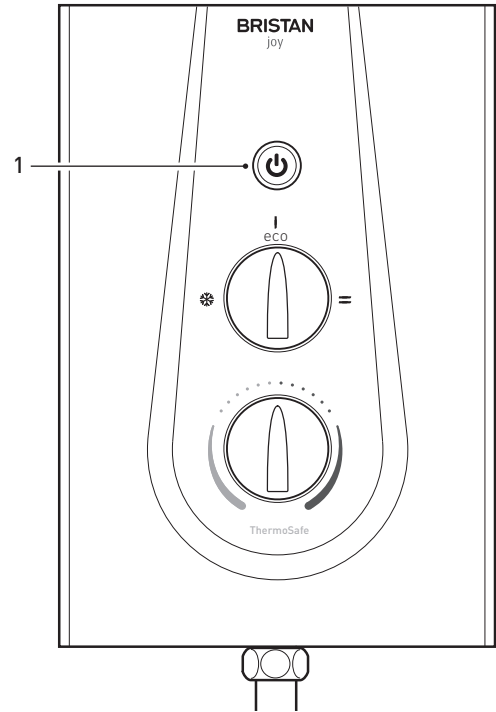

Warning: This appliance is not intended for use by persons (including children) with reduced physical, sensory or mental capabilities, or lack of experience and knowledge, unless they have been given supervision or instruction concerning use of the appliance by a person responsible for their safety.

Important: Children should be supervised to ensure that they do not play with the appliance.

Important: The shower unit must be switched off at the isolating switch (pull cord) when not in use.

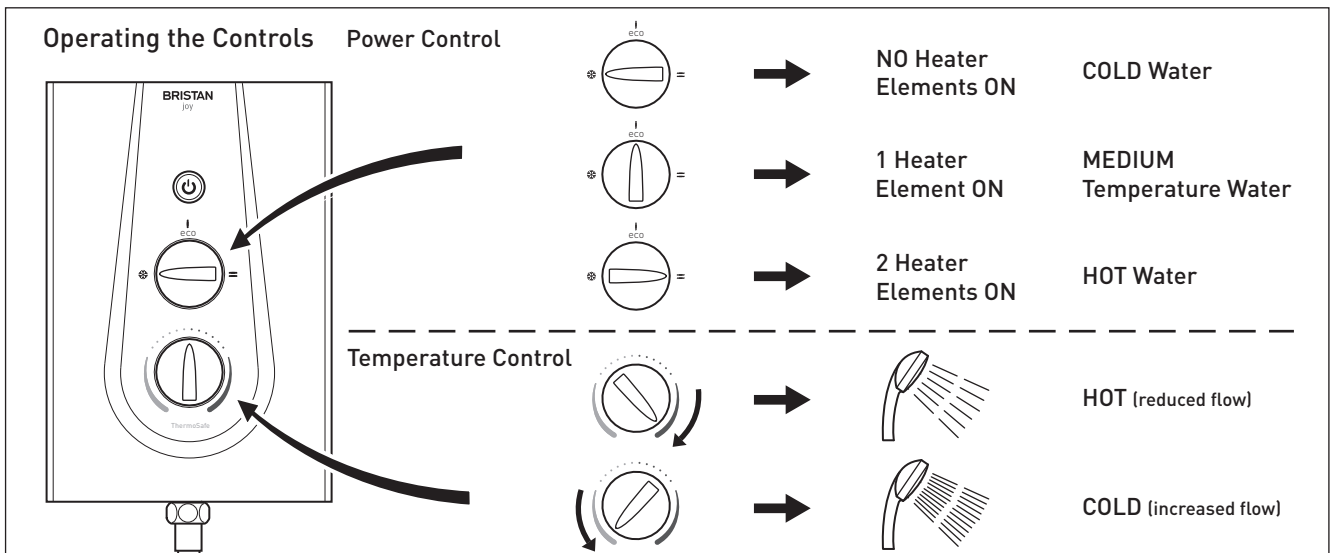

Operating the Shower cont.

Adjusting the Showerhead

Your Joy showerhead has 3 spray modes - spray, jet spray and combination. Simply rotate the spray head one way or the other until it 'clicks' into the desired spray pattern.

Note: The spray head mode may need to be altered during winter conditions (low flow conditions) to achieve a satisfactory spray.

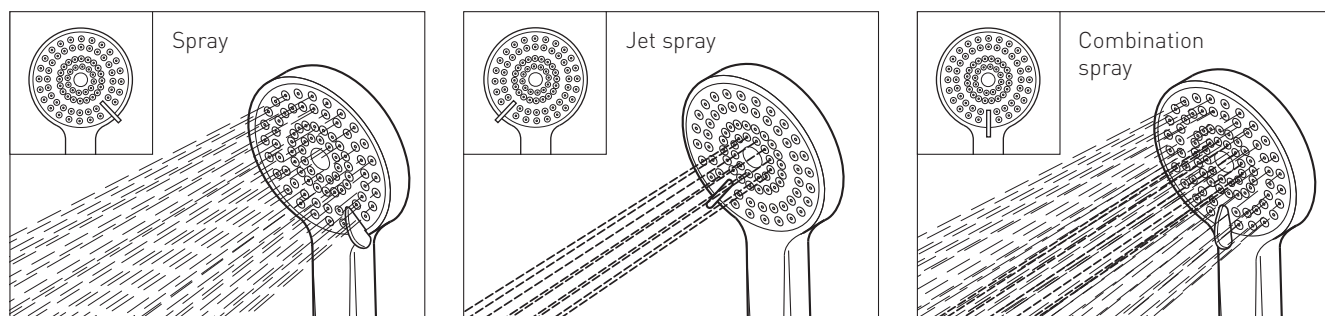

Maintenance

General Cleaning

Before attempting to clean your shower unit you must switch off the power at the isolating switch. Do not remove the cover.

Do not use abrasive cleaners or solvents to clean this unit. The shower unit and accessories should be cleaned with a soft, clean, damp cloth.

Bristan recommend E-cloth for cleaning all of our bathroom and Kitchen products. Using just water, E-cloth gives smear free, deep clean by breaking up and holding dirt, which normal cloths leave behind. Order through your Bristan stockist (Order code: Ecloth).



Cleaning the Showerhead

Your Bristan showerhead has a rub-clean pad for easy cleaning. Simply rub your fingers across the rubber spray jets regularly and before you turn the shower on to remove any scale or debris.

The hardness of the water in your area will determine how often you should clean your showerhead. Build up of scale in particularly hard water areas combined with constant use means you may need to clean your showerhead once a week. To ensure continued performance of your electric shower the showerhead needs to be regularly descaled.

continued on next page

Maintenance cont.

Cleaning the Filter

Periodically remove the inlet filter and rinse under clean running water. First isolate the electrical and water supply to the unit.

To remove: Turn anti-clockwise using a large flatblade screwdriver.

Note: A small amount of water will be discharged when the filter is removed - this is normal.

To clean: Wash under clean running water. Refit the filter and gently tighten.

Cleaning the Outlet Hose Mesh Filter

Periodically remove the outlet hose from the shower and clean by rinsing the mesh filter under cold running water. Refit the mesh filter and re-connect the outlet hose.

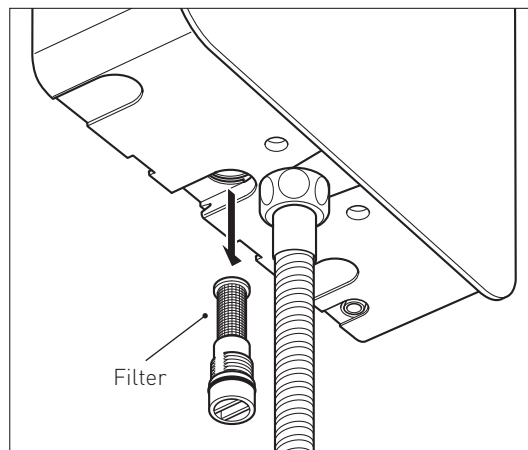

Troubleshooting

Symptom	Likely Cause/s	Action/Remedy
No water flow.	Water isolating valve in off position. Filter blocked. Outlet hose mesh filter blocked. Power supply not on.	Turn on. Turn off water supply, remove filter and clean. Remove the outlet hose from the shower, remove mesh filter and clean. Turn on.
Water temperature too hot.	Insufficient water flowing through the shower.	Clean the handset. Increase the flow by adjusting the temperature control knob to cooler setting. Reduce the power setting.
Shower runs hot and cold during use.	Water pressure is at minimum requirement.	Check running pressure (minimum of 0.7bar). Wait until pressure increases.
Shower temperature cycles between hot and cold.	Shower temperature is set too high causing the thermal cut out to turn off the heating elements to reduce the water temperature.	Turn shower temperature control anti-clockwise to reduce the water temperature.
Water from pressure relief outlet-PRD activated.	Obstruction in hose or handset.	Call Customer Services.
Letters 'LP' appear on the front panel just above the START/STOP button.	Low Pressure water supply to shower unit. Low water flow through shower handset.	Turn off unit and wait until water pressure increases before using again. Increase water flow rate by turning temperature control to cooler setting.
Error code 'E1' appears on the front panel just above the START/STOP button.	Outlet water temperature thermistor faulty.	Call Customer Services.

Guarantee

Guarantee

Thank you for purchasing a Bristan product. This product has been designed and tested, in the UK, to the highest standards.

Guarantee: 2 Year parts.
1 Year labour (subject to registration).

This guarantee applies to products purchased within the United Kingdom or Republic of Ireland, but does not apply to products used commercially.

This is provided that:

1. The guarantee registration card is completed and returned within ten days complete with a copy of proof of purchase. Proof of purchase is required for any servicing requirements.
2. The product is installed and operated in accordance with our instructions, the I.E.E Wiring Regulations, and Building Regulations (Part P), and has not been misused or damaged.

This in no way affects your statutory rights as a consumer.

The information on the Guarantee card helps Bristan to process any claims and contact you about your product and its maintenance if required. The registration of your personal details is purely for Bristan use and the remaining information helps us to make products for the future.

Should a complaint arise, products are guaranteed against faulty workmanship and materials for a period of 12 months from the date of purchase, when in domestic use (second year guarantee is parts only). For your guarantee to be valid, your shower must be installed by a competent person, in accordance with the instruction manual.

Bristan will repair or replace (at our option), free of charge, any faulty components during the guarantee period, provided it has been maintained and operated in accordance with our instructions, and has not been misused or damaged.

Modification or repair of this product by person(s) not authorised by Bristan will invalidate this guarantee.

This guarantee does not affect your statutory rights.

Service Policy

Replacement Parts Policy

Important:

In the event of product or component malfunction, DO NOT tamper with or remove the product from site. Telephone the Customer Services Department and be prepared with the date of purchase, model number and a clear description of the complaint.

Our service staff are fully qualified to advise on correct installation procedures and will be able to diagnose whether the fault will require a replacement part or a visit from a Bristan engineer.

If required, a service call will be booked and either yourself or an appointed representative (who should be a person of 18 years or over) must be present during the visit.

All site visits to product within the guarantee period will be carried out free of any parts or labour charges provided the conditions of the guarantee have been adhered to (the second year guarantee is parts only).

All site visits to product out of guarantee will be subject to charges for parts and labour. Charges will also be levied on cancelled appointments, unless advised to Bristan at least 24 hours in advance of the agreed date and time.

Should a product be discontinued, spare parts stocks will be maintained, but in the event of a part becoming unavailable Bristan reserve the right to supply a substitute of equal quality.

Please visit: www.bristan.com/sparesfinder in order to find spare parts for this product.

Opening times: Please refer to the Bristan website.

Customer Service:

Tel: 0844 7016273 • Fax: 0844 7016275

E-mail: enquire@bristan.com

Spare Parts

Please visit: www.bristan.com/sparesfinder in order to find spare parts for this product.

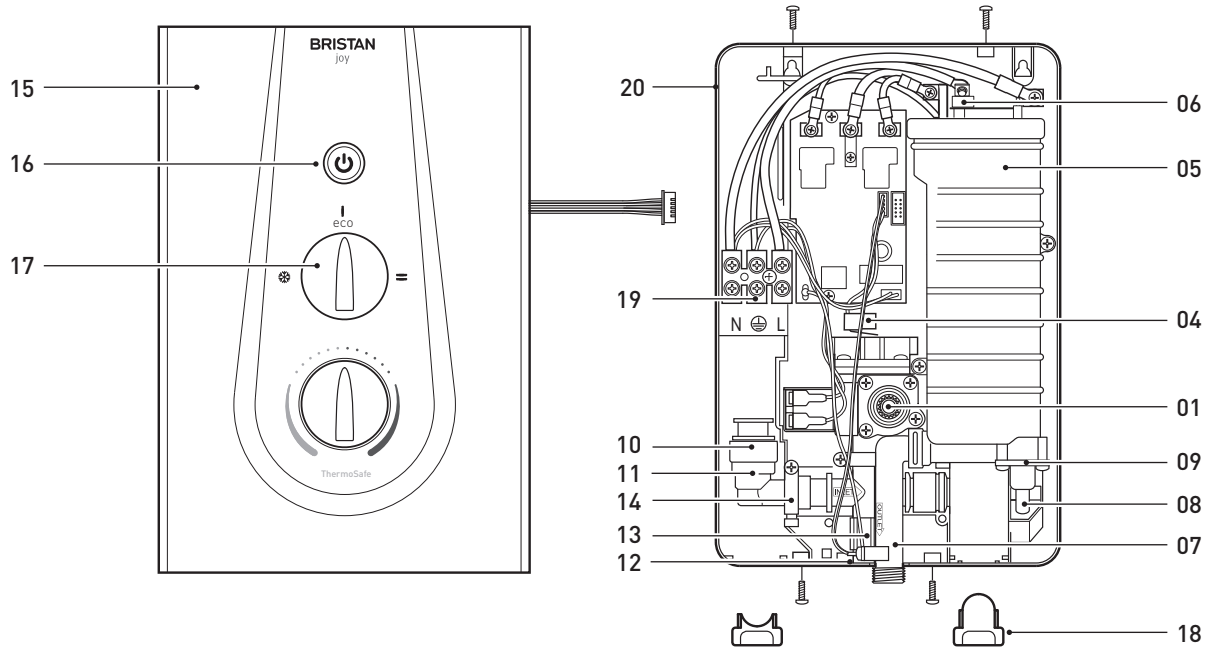

No.	Part No.	Description	Parts List	Quantity
01	131-140-S-85	Stabiliser Valve Ass. 8.5 KW	Stabiliser Valve x1, inc. O-rings x2	1
01	131-140-S-95	Stabiliser Valve Ass. 9.5 KW	Stabiliser Valve x1, inc. O-rings x2	1
04	131-209	Auxiliary Microswitch	Auxiliary Microswitch x1	1
05	131-300-3-85	Heat Exchange Unit Ass. 8.5 kW	Heat Exchange Unit 8.5 kW x1, Metal Clip x1, inc. O-rings x2	1
05	131-300-3-95	Heat Exchange Unit Ass. 9.5 kW	Heat Exchange Unit 9.5 kW x1, Metal Clip x1, inc. O-rings x2	1
06	131-307-S	Thermal Cut Out Ass.	Thermal Cut Out x1, inc. Screws x2	1
07	131-315-S-2	Outlet Pipe Ass. (with hole)	Outlet Pipe x1, Metal Clip x1, inc. O-ring x1	1
08	131-309-S	Pressure Relief Diaphragm Housing Ass.	Pressure Relief Diaphragm Housing x1, inc. Screws x2	1
09	131-308	Pressure Relief Diaphragm	Pressure Relief Diaphragm x1	1
10	131-400-S	Water Inlet Ass.	Inlet Elbow x1, Swivel Inlet Pipe x1, Filter x1, inc. O-rings x3	1
11	131-406-S	Inlet Elbow Ass.	Inlet Elbow x1, inc. O-ring x1	1
12	131-404-S	Filter Ass.	Filter x1, inc. O-ring x1	1
13	131-402-S	Swivel Inlet Pipe Ass.	Swivel Inlet Pipe x1, inc. O-ring x1	1
14	131-401	Inlet Pipe Clamp	Inlet Pipe Clamp x1	2
15	131-667-JOY-T-W	Joy Front Cover - WHITE	White Front Cover x1	1
17	131-725-S	Control Dial Ass.	Control Dial x1, inc. O-ring x1, Screw x1	2
18	131-600-S-W	Fixing Kit Ass. - WHITE	Full Shield x2, Half Shield x1, Wall Screw x3, Wall plug x3, Cover Screw x4	1
19	131-607	Wire Terminal	Mains Terminal Block x1	1
20	131-501	Rubber Seal	Front Cover Seal x1	1

Spare Parts

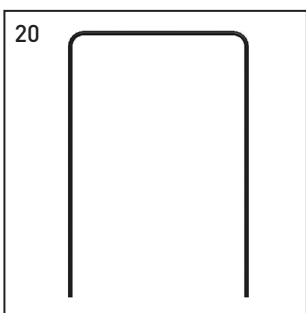
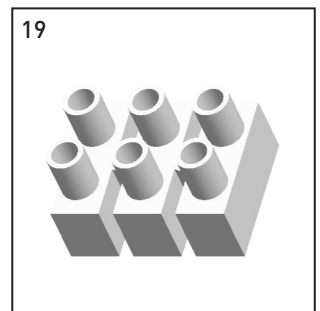
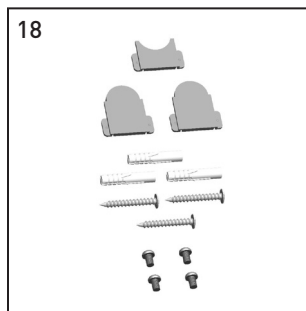
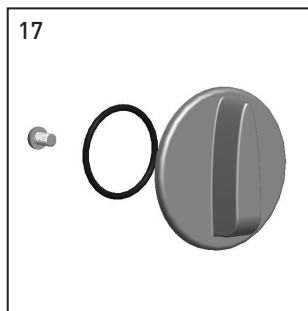
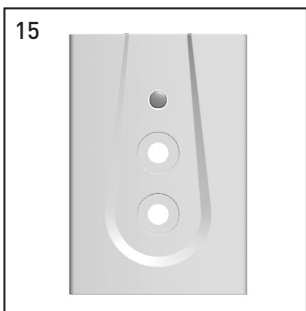
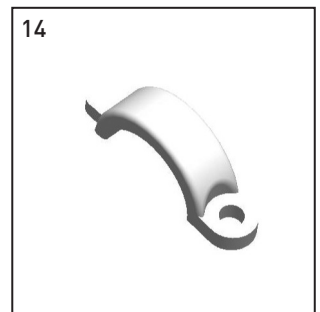
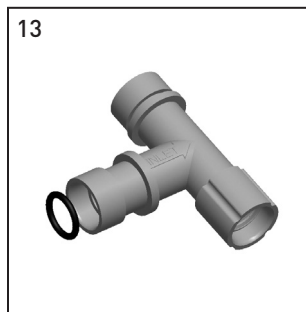
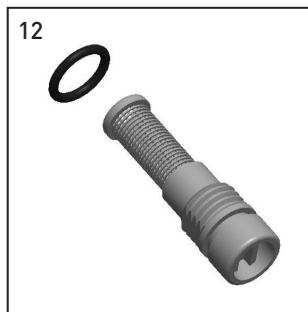
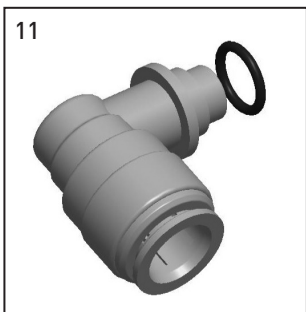
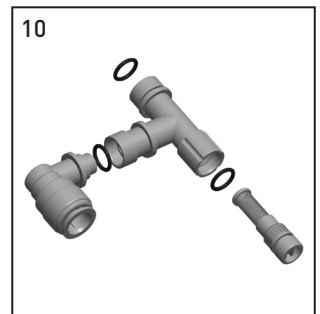
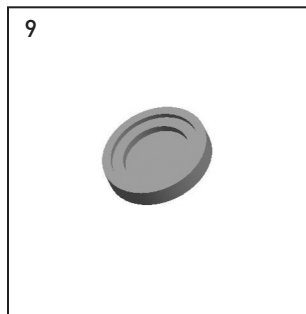
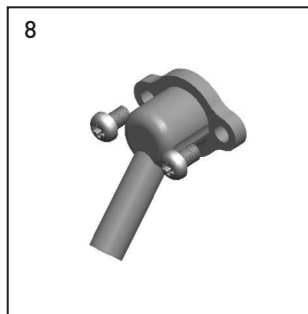
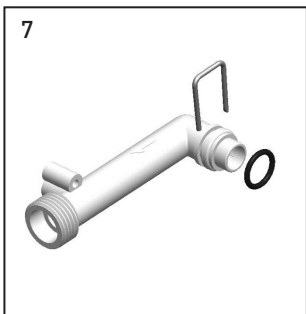
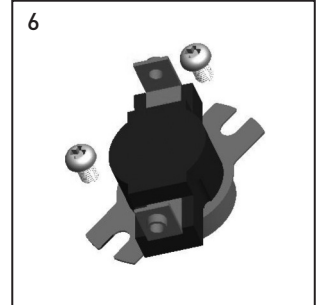
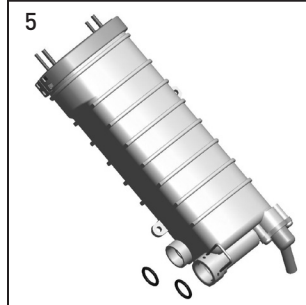
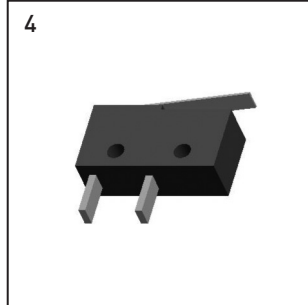
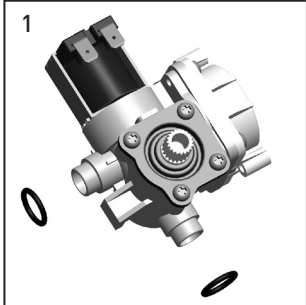

Spare Parts cont.

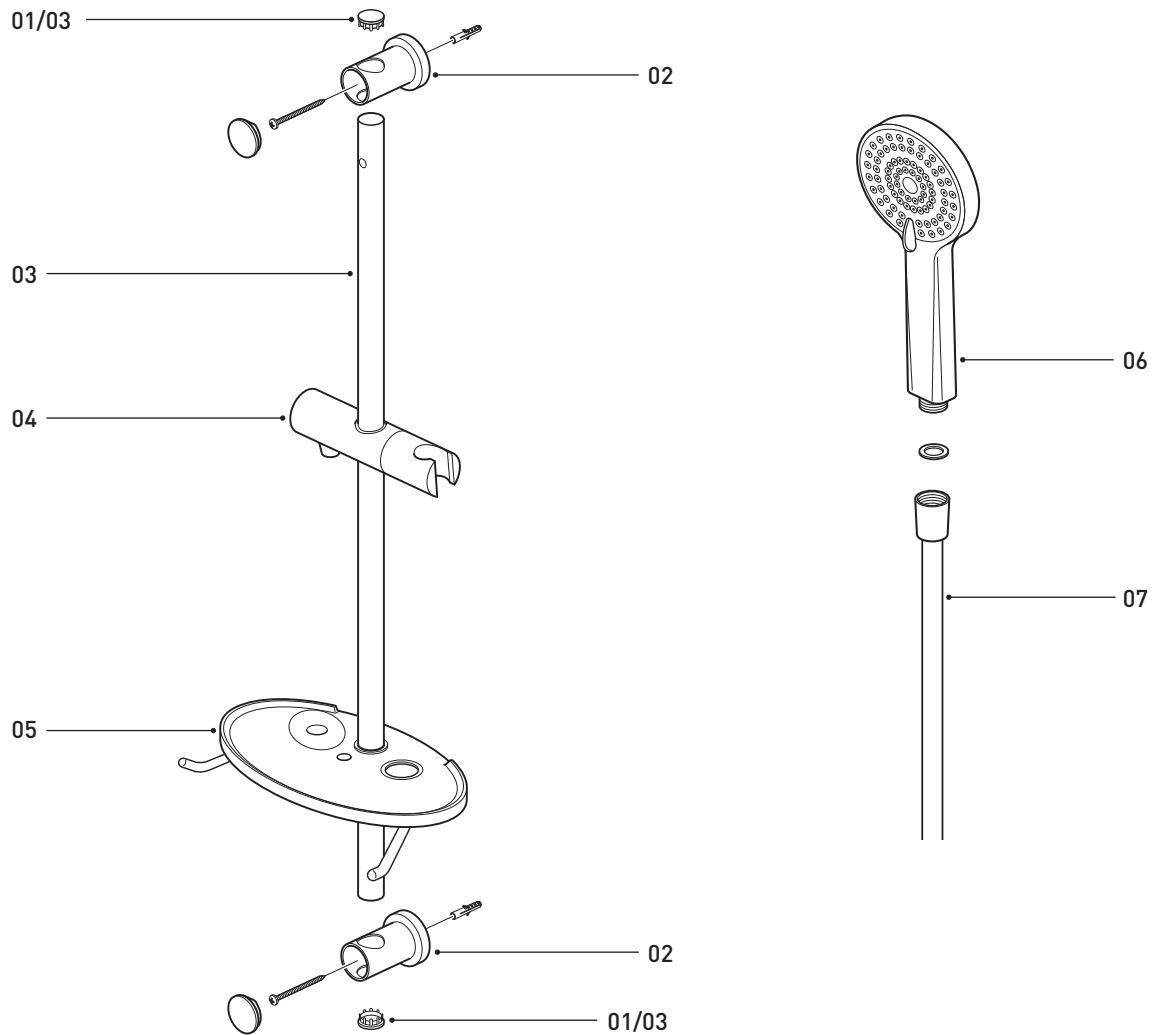

No.	Part No.	Description	Parts List	Quantity
01	1408A0A	Riser Rail End Cap	Riser Rail End Cap x1	2
02	11043A0A	Wall Bracket Ass.	Wall Brackets x2, Wall Bracket End Caps x2, Screws x2, Wall Plugs x2	1
03	207041-012C	Riser Rail Ass.	Riser Rail x1, Riser Rail End Caps x2	1
04	1625A0A	Slider/Handset Holder	Slider/Handset Holder x1	1
05	11046A0A	Soap Dish	Soap Dish x1	1
06	61000018	Handset	Handset x1	1
07	63000008	Hose Ass.	Hose x1, Rubber Washers x2	1

Issue FI ES Joy - H

Part Number 131 - 723

BRISTAN

Bristan Group Ltd.
Birch Coppice Business Park
Dordon
Tamworth
Staffordshire
B78 1SG
Web: www.bristan.com
Email: enquire@bristan.com

A Masco Company