

R11

Instruction pack

28/09/2011

Leygrove

2960x4340

		28mm log
--	--	----------

Supplied in 2 packs

**CHECK ALL PARTS BEFORE ASSEMBLY
OR EMPLOYING TRADESPEOPLE**

LOG SHEET

SEE PARTS LIST FOR ID No

Building: **Leygrove**
 Building Size: **2960x4340**
 Date: **25-May-11**

LOG 28mm MM

Log	Length	Quantity
A	2960	38
A1	2960	2
C	285	11
F	287	28
G	287	31
I	4340	20
L	410	16
M	518	11
N	1772	1
N1	1772	1
N2	1772	1
N3	1772	1
O	2978	2
O1	2978	1
O2	2978	1
P	2978	4
P1	2978	1
Q	1598	7
Q1	1598	1
Q2	1598	1
Q3	1598	1
0	0	0
0	0	0

SPARE LOGS

A	2	
I	1	
F	1	
G	1	
M	1	
L	1	

roof panels no bearers

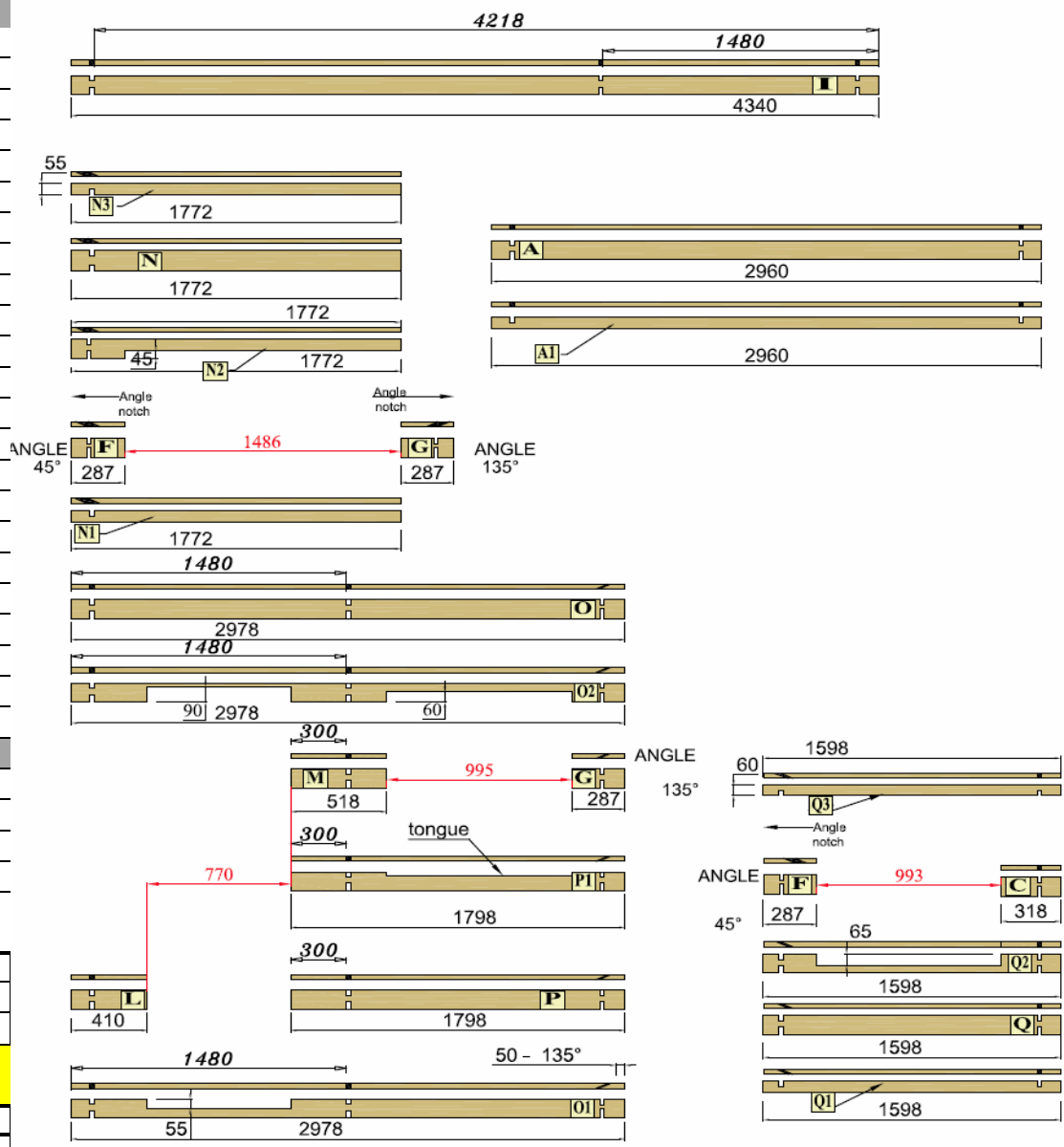

SHIRE

BUILT AROUND OUR REPUTATION

34/44/70 DOUBLE DOOR -INNER FRAME ASSEMBLY

SCREW
HERE
T

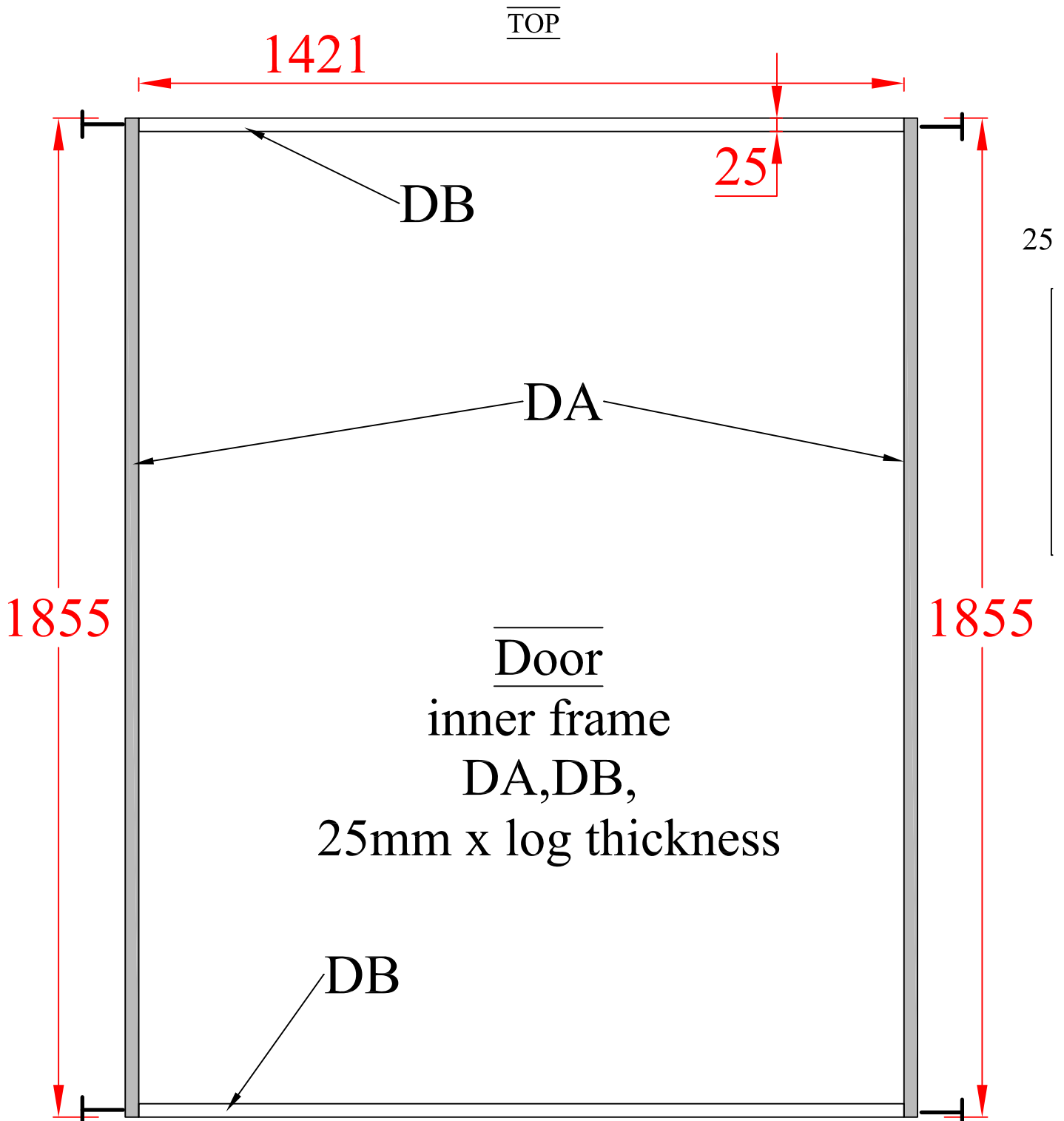

SHIRE

BUILT AROUND OUR REPUTATION

1777-2		1421-2	rubber
1600			drip bar

28/34/44/70DOUBLE DOOR OUTER FRAME ASSEMBLY

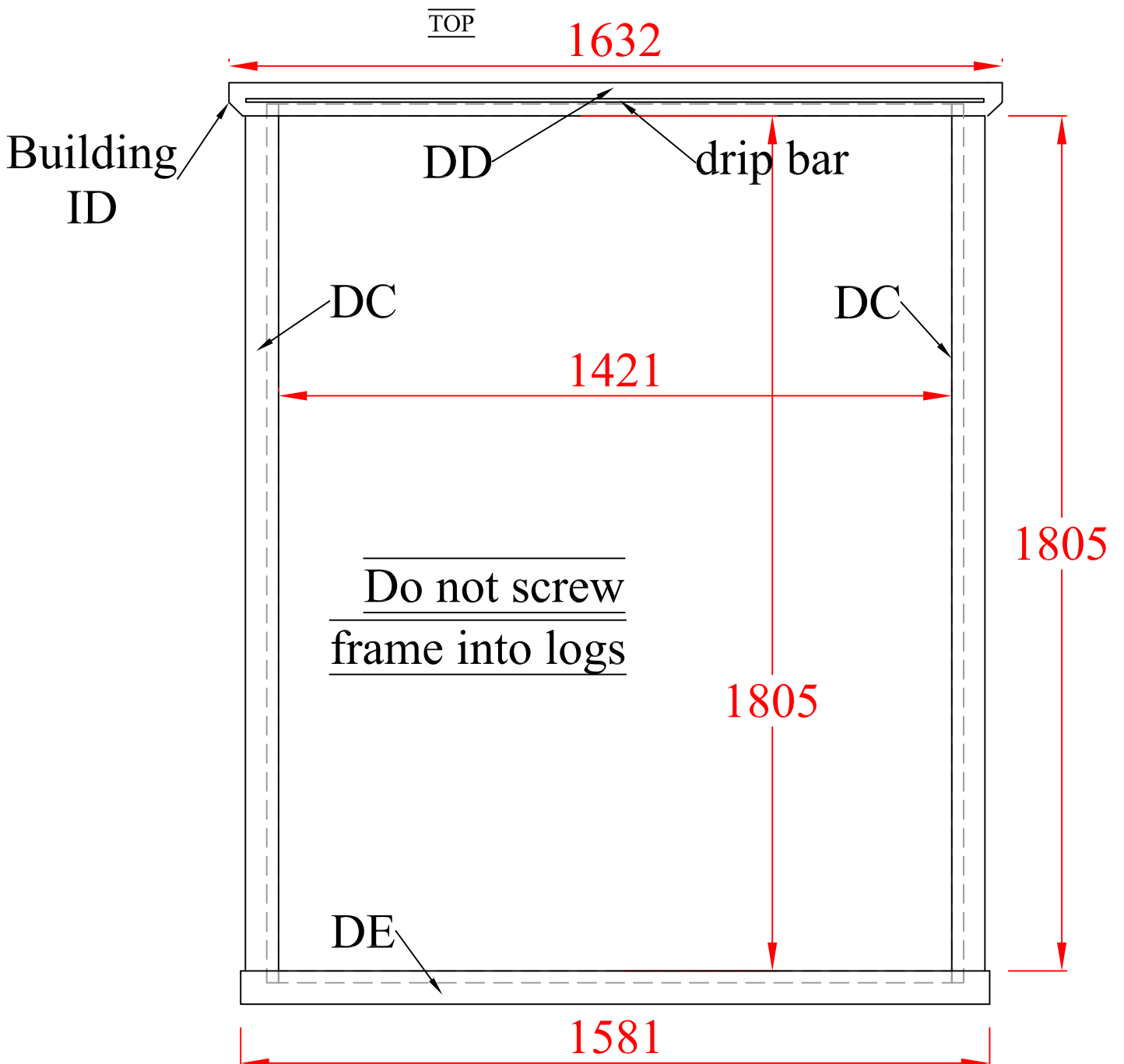

W9S
WINDOW
-INNER FRAME
ASSEMBLY

Window
inner frame
WA, WB, WT
25xlog thickness

TOP

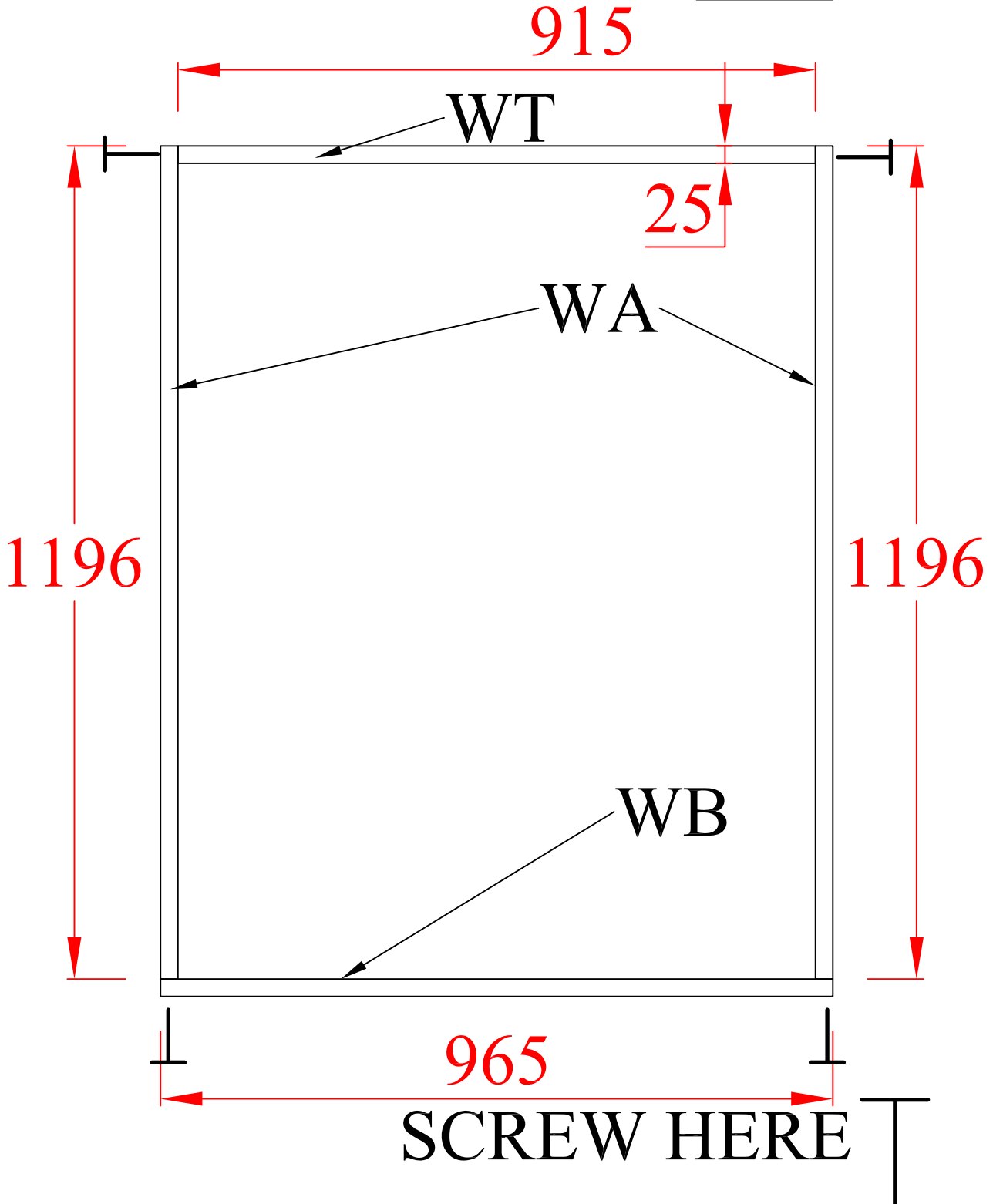

SHIRE TOP

BUILT AROUND OUR REPUTATION

W9S WINDOW- OUTER FRAME ASSEMBLY

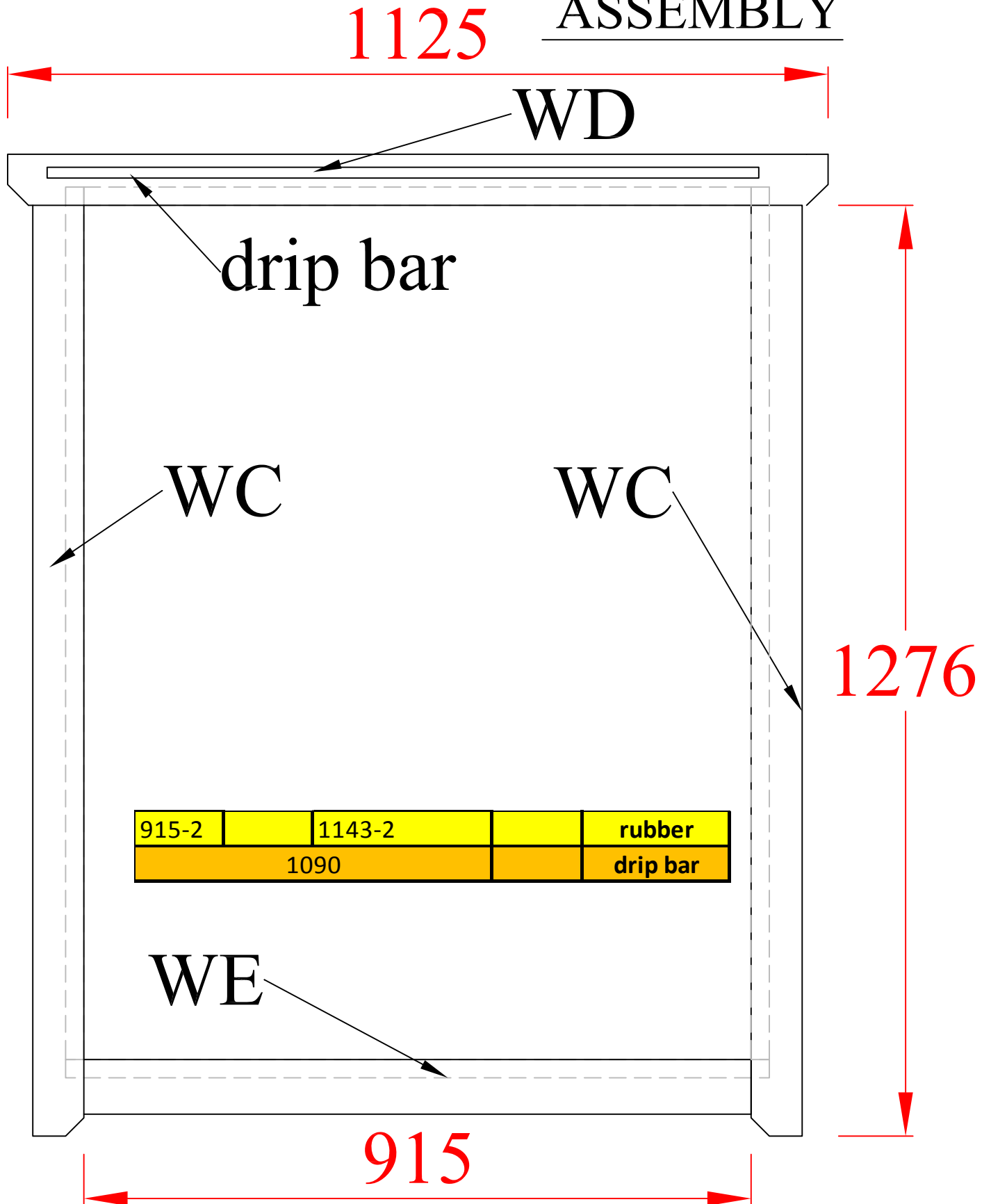

Assembly of Leygrove pine lodge ©

Thank you and congratulations on the purchase of your Shire pine lodge. We believe that this product will give you many years of excellent service. This is a natural product manufactured to a high standard therefore if you have any queries or experience any difficulties then please contact our customer Service hotline on

01945 46 89 10 01945 46 89 11 01945 46 89 12

Normal office hours: 8.30am to 5.00pm Monday to Friday. Answer phone all other times.



Preparation of base

The base onto which you build your Cabin needs to be flat and level. We only recommend you use concrete that is a minimum of 10 cm thick

Base size at least 4150mm x 2770mm

Please refer to section E and drawing page 1

Please note that the corner joints protrude over the edge of the base.

Treatment/care of your pine lodge

Tools required

- Hammer
- Rubber mallet
- Spirit level
- Stepladder
- Battery-powered drill/screwdriver
- 8mm drill
- 3mm drill
- Tape measure
- Gloves
- Sharp knife and saw
- Chalk
- String
- Oil for lock

IMPORTANT!

1. Check all components before commencing with the construction of your Corner cabin

2. Keep all timber dry or your building will not fit together.

3. We also recommend that you seal the corner log joints with silicone sealant (not supplied).

4. We recommend a minimum of two people required for assembly.

5. Read through all the instructions before constructing your pine lodge.

6. You will see there is a set of lettered drawings showing each side of the building. You will find these letters printed at one end of each log or in the slot.

PLEASE NOTE

Wood is a natural product and is therefore prone to changes in appearance, including some warping, movement and splitting, particularly during unusual climatic conditions (long hot or wet spells of weather). As a natural occurrence this is not covered by a guarantee.

- All timber must be dry to apply the timber treatment.
 - Treat with a suitable decorative wood finish immediately. We recommend that you treat the door and window glazing rebates and beading with a top quality timber treatment before assembly and treat the entire building as soon as assembly is complete, we further recommend that all pieces are treated and again within 3 months of assembly and again at least annually or as frequently as the instructions on the product used recommends.
 - **Note** the back of the door and window units unscrew so they can be removed for painting
 - We would also remind you that you would rarely (if ever) be able to re-treat the underside of the floor boards following assembly.
 - We strongly recommend that the underside of the floor is treated an absolute minimum of twice.
 - The floor bearers are pressure treated and don't need to be treated although you may if you wish. We also recommend that you seal the external corner joints (fig D2) with silicone sealant (not supplied)
 - **LUBRICATE LOCK** It is extremely important that you lubricate your lock through the key hole and all moving parts as soon as possible after assembly and at least at monthly intervals thereafter. Also ensure that you regularly operate the lock especially during the winter or when not in use.
- ◆ See drawings for log quantities
 - ◆ See yellow parts list sheet please quote ID number and your order number in all correspondence
 - ◆ * Note the Angled eaves edging, Eaves fascia & roof edging may be supplied in shorter lengths.

IMPORTANT!

The only parts that require cutting are the corner top logs, roof edgings, eaves fascia & skirting .
DO NOT CUT ANYTHING ELSE

Assembly of Cabin—please read instructions and check all parts prior to assembly

IMPORTANT SAFETY INFORMATION

- We recommend the wearing of non-slip protective gloves throughout the assembly process. We also recommend the wearing of steel capped protective shoes, protective head gear, safety glasses and full length clothing. If step ladders are to be used we recommend one person holds the ladder whilst the other is using them. If necessary a third person should be used. Do not attempt to erect the building in windy conditions. Follow any safety precautions quoted by the manufacturer for any equipment you use.
- Every precaution has been taken to ensure that your building has no element incorrectly placed or possibly hazardous. However prior to use please check for raised grain or splinters and sand if necessary. Check that all elements are secure against reasonable force.

A Window Frame

1. Refer to the window drawing page and to letter codes in contents table. The WT and WD parts will be at the top of the window frame. Do not tighten the inside of the frames so you can remove for treatment.
2. To be sure you can lay all the pieces, including inserts together without fixing to familiarise yourself with the assembly.
3. Make sure the window insert fits inside the frame with a 5mm gap all around.
4. Lay out the parts WA and WB and WT as in the inner frame assembly drawing. The narrowest (25mm) edge to the work bench and the side the size is the same as the log thickness as shown in fig A1. Part WT must be inside parts WA and part WB underneath the two WA parts (Fig A1).
5. Pre drill 2 3mm holes at one end of the WA only and at both ends of the WB parts (see drawing) and screw together at each corner, 10mm in from the edge (ensuring each corner is flush) with 2x50mm screw (fig A1).

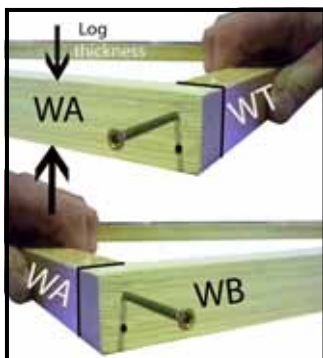

Fig A1

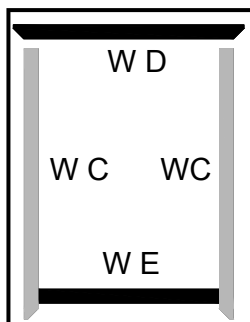

Fig A2

7. Layout parts WC, WD & WE as in fig A2 & drawing on top of the frame from steps 1-6 flush with the inner edge of the frame.



Fig A3

8. Mark the first hole position 30mm from the end of part WC that is next to part WD, at the other end mark the hole central to the WB underneath and then the rest at approximately 260mm centres between these holes.
9. Note the WC, WD & WE pieces fitted to the opposite side must be drilled offset to this side to ensure the screws miss each other.
10. Place the other WC part underneath and drill through both pieces with a 3mm drill (fig A3).



Fig A4

11. Place one of the WC parts on top of the WA parts level with the inside of the frame and the bottom of the WT part (fig A4).
12. Fix to part WC to WA with 40mm screws (fig A5 & A6)
13. **important** fix at both ends first ensuring that they stay flush then the screws in between again ensuring that parts WA & WC are flush as you go



Fig A5

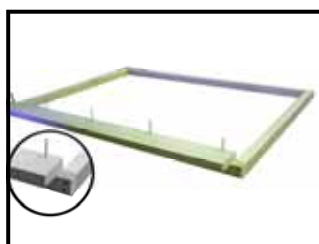

Fig A6

14. Place a WD part on top of a WB part. The WD part is positioned so there is an even overhang (fig A7). Mark out and drill fix as steps 8 to 10. But start at 100mm from the end of part WD.



Fig A7

15. Drill (not too deep) and screw in each corner with 40mm screws (fig A8).



Fig A8

16. With a pencil mark the screw centres on the inside long edge of the frame to help ensure the hinge screws will miss these screws.
17. Turn frame over and repeat steps 4 to 12 on the other side (fig A9 & A10).
18. **Note offset drilled holes from first side to ensure they miss each other first hole part WC =30mm part WD =100mm**

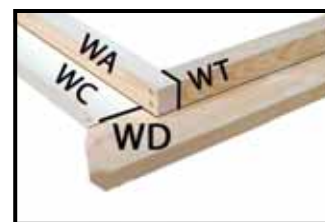

Fig A9



Fig A10

19. **Window insert.** Place one hinge on the inner rebate part of the window; approx. One hinge width along from the rebate edge on the top side. The rounded part of the hinge should sit above the outer edge of the window. Screw the inner piece into position
20. (fig. A11 & A12) using the pre drilled holes in the hinge and 3 x 25mm screws. Repeat with the other hinge. And close the hinges together.

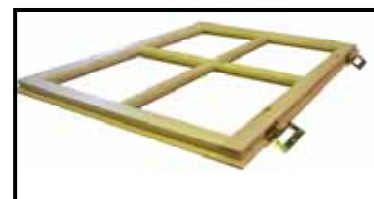

Fig A11— STYLE MAY VARY

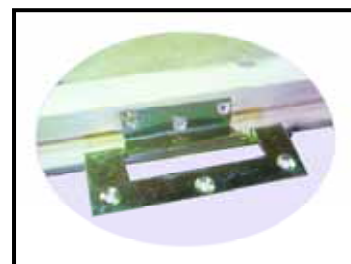

Fig A12

22. Place the window into the aperture (fig A13) ensure that part WD (FIG A13) is against the hinges (TOP HUNG) or against the WC (side hung).
23. Secure the window to the panel using 3x 25mm screws per hinge, (fig. A14) again through the predrilled holes in the hinge.
24. Repeat.



Fig A13



Fig A14

24. Open the window fully in order to fit a further 2x 25mm screws per hinge (Fig.A15).

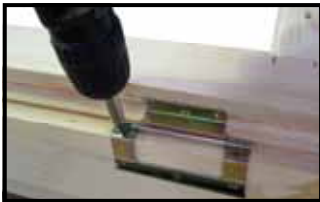

Fig A15

25. Fitting the draught excluder.
This must be done before fitting the casement stays.



Fig A16

26. Lay the assembled window unit with the opening insert downwards onto your work surface (Fig A16).
27. Position the draught strips so the rubber is against the opening insert and fix with 4x25mm oval nails per strip (Fig A16).
28. **Fitting the Casement Stays.** There are two per window. Place the casement stays evenly on the inside of the window (Fig A17) on top of the draught excluder.
29. Place the 2 pins under each casement stay. Position so that it is not resting on the window frame and not so high that the pins are of no use.

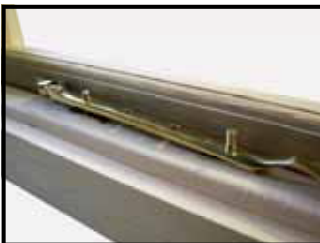

Fig A17

30. Fit the Casement Stay (fig A18) on the window using 2x 25mm screws.



Fig A18

31. Mark where the 'pins' will be placed.



Fig A19

32. Secure into position using 4x 25mm screws - 2 in each pin.
33. **Drip bar.** Turn the window unit over so the opening insert is uppermost .



Fig A20

34. Position the drip bar by measuring 45mm down from the top of the **WD** part above the hinges and fix the drip bar with 3x25mm screws. Repeat with the other window unit
35. Put the completed units to one side until required .
36. **Note** do not glaze until all parts have been treated and the units fitted in the building

B Door Frame-Double door only

1. Refer to letter codes in the contents table and also use the doors as a gauge to ensure correct assembly (assembly similar to but not the same as the windows). **SEE LARGE DRAWINGS. Do not tighten the inside of the frames so you can remove for treatment and fixing logs.**
2. Lay out the parts **DA** and **DB** as in fig 27. The 25mm edge to the work surface

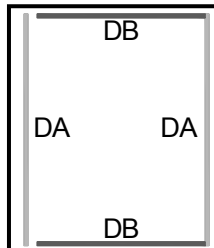

Fig 27

3. Parts **DB** must be inside parts **DA**

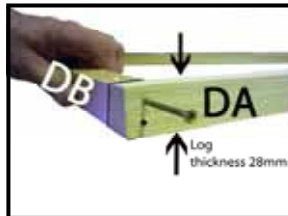

Fig 28

4. Drill both ends of the **DA** and screw together at each corner, 10mm in from the edge (ensuring each corner is flush) with 2x50mm screws (fig 28).

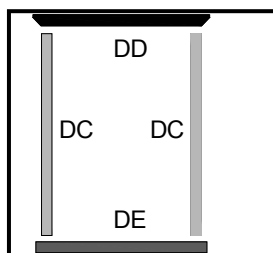

Fig 29

5. Layout parts **DC**, **DD** & **DE** as in fig 29 .
6. Mark the first hole position 30mm from each end of part **DC** and then the rest at approximately 200mm centres.
7. **Note** the **DC**, **DD** & **DE** pieces fitted to the opposite side must be drilled offset to this side to ensure the screws miss each other.

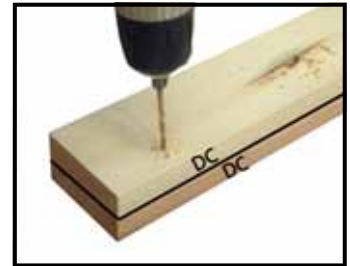

Fig 30

8. Place the other **DC** part underneath and drill through both pieces with a 3mm drill (fig 30)



Fig 31

9. Place one of the **DC** parts on top of the **DA** parts level with the inside of the frame (fig 31)

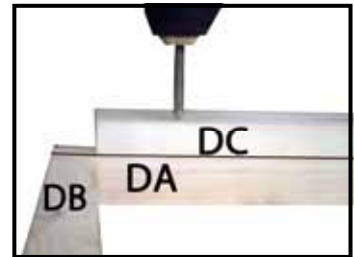

Fig 32

10. Fix to part **DC** to **DA** with 40mm screws (fig 32 & 33) **important** fix at both ends first ensuring that they stay flush then the screws in between again ensuring that parts **DA** & **DC** are flush as you go.



Fig 33

11. Place a **DD** part on top of a **DB** part. the **DD** part is positioned so there is an even overhang (fig33). Mark out and drill fix as steps 8 to 10. **But** start at 100mm from the end of part **DD**.



Fig 34

12. Drill (not too deep) and screw in each corner with 40mm screws (fig 35).

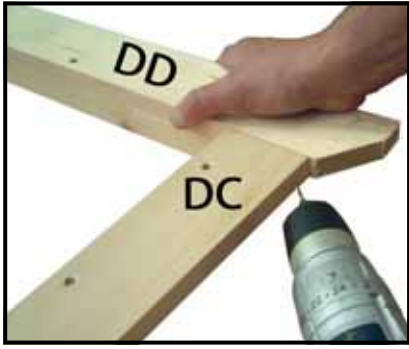

Fig 35

13. With a pencil mark the screw centres on the inside long edge of the frame to help ensure the door hinge screws will miss these screws.
 14. Turn frame over and repeat steps 5 to 13 on the other side
 15. **Note offset drilled holes from first side to ensure they miss each other first hole part DC=40mm part DD =110mm**

C Fit Doors

- Lay doors on the floor, as you would view them from the inside of the building. Make sure the door with the lock is situated on the left when viewed from the bottom.
- Lay the outer frame in position (fig 37).
- The hinges are fitted on the longest outside edge of the doors.
- Make a visual judgement to the gap top and bottom of the doors then transfer the screw centre marks (step B 13) to the doors. This is to ensure the hinge screws miss the frame screws.
- Lift off the outer frame making note of which way around you have put it.
- Place the hinges as shown in fig 36. Screw the inner piece of the hinge to the door with 2 x 25mm screws.

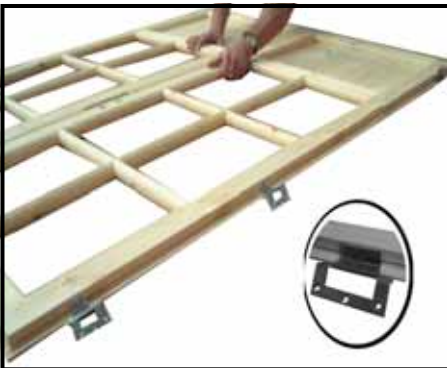

Fig 36

7. Close the hinges and lay the frame assembly over the doors (fig 37).



Fig 37

8. Make a visual judgement to set an even gap top/bottom of the doors and secure each hinge with 1x25mm screws (fig 38). **Ensure the hinges are tight against the face of the doorframe.**



Fig 38

9. Stand the assembly up. Note two people needed for this step. Open the doors and secure hinges with remaining 4x25mm screws per hinge.
 10. Lay the assembly down again with the doors facing down and fix the draught excluder as with the windows using 9x35mm oval nails for either side and 9x35mm oval nails each top and bottom. Take note of where you are going to put the door bolts (step 12).
 11. **Drip bar**. Turn the unit over and measure down 45mm and position and fix with 6x25mm screws as previously done with the window unit.



Fig 39

12. Fit two bolts on the door without the lock (fig 39). The top bolt should be positioned just below the draught excluder. Fix with 4 screws supplied.
 13. Extend the bolt to meet the frame with the cranked part as far from the edge as you can and mark then drill a 10mm hole (**into , not through the frame**) to take the bolt.
 14. Align the catch plate and fix with 4 screws supplied
 15. Put the door assembly to one side until required.

D Setting out

- It is extremely important that you read the instructions carefully and familiarise yourself with all the components before continuing with the build.
- The plan drawing (page 1) and shows the building position
- The logs are always fitted with the tongues upwards.
- All the drawings are viewed from the outside looking inwards.
- Keep all parts clean and dry whilst working as any contamination before treatment is hard to remove !**



Fig 42 example

6. Lay out all the logs around the build area (fig 42) in piles as you need to assemble them, for example on the RH. window view you may stack the logs in a similar way to the following **EXAMPLE :-**

1 LOG Q1
 5 Logs Q
 1 Log Q2
 11 Logs F 11 Logs C
 2 Logs Q
 1 Log Q3

E Floor bearers and first logs

See drawing pages

Use the following instructions and the drawing pages to assemble your building .

- The outermost bearers are two bearers that sit side by side (may be joined). Take these bearers and nail them together 10 x 75mm nails (fig 43). **DOUBLE JOINED BEARERS** place brick style and nail as above (see drgs). **JOINED BEARERS**, place a joiner next to the join and nail as above with 6 x 70mm nails
- Do not nail near one end** on the shorter pair as this needs to be trimmed –step **E 20 ONWARDS**



Fig 43

3. **To Help familiarise you with the layout-** Roughly place the bearers into position (spacing not important at this stage) and **ROUGHLY** place the half logs **A1, N1 and Q1** into position .Next place the first full logs **-just rest them in position- DO NOT TAP HOME -(fig 44).**



Fig 44

4. Once you are happy that you are familiar the layout then proceed with the assembly.
 5. **TIP** as you disassemble the logs in the next steps, place a visible mark in each outside viewed LH notch to help with orientation.



Fig 45

- Take the **A1** half height log (drawing page 10 , GABLE END) and mark the floor bearer centres less than 20mm long (these marks will be inside the building behind the skirting) along the bottom edge of the log as shown in the drawing, but not the two pairs of outer bearers, from one end (fig 45) keeping note of its orientation (step 6 mark downwards on the work surface and to the left)



Fig 46

- Place the '**Q1**' log against the **A1** log (bottom edge to bottom edge) (step 6 mark downwards on the work surface and to the opposite end of the mark on the first log)and transfer all the lines across (fig 46). **Building with storeroom mark both A1 LOGS.**
- Repeat step 7 **only** with the **N1** (Door view page 2)
- The bearers stand with the narrowest edge to the floor (fig 47 & 48) and their end level with the **A1** log faces.



Fig 47

- Assemble the first row of logs on top of the bearers by placing the half height logs in position and then the first of the logs from each wall that run parallel to the bearers on top of them **EXCEPT log G door view.**(See section **F4** for tapping down instructions).

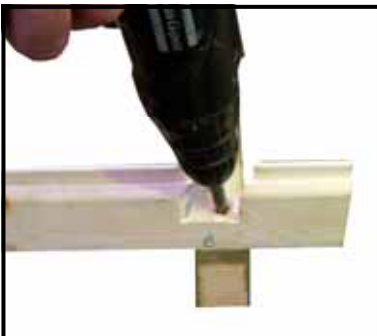

Fig 48

- Centrally align the bearer that goes under the angled notch on log **Q1** **lh window view** ,drill through the log only in the centre of the notch and fix with 1x60mm screw (fig 48) ensure that the screw is flush with the surface. Position the **log G door view** on top of this joint and tap home as before.
- NOTE** the shortest pair and the two mid length bearers **WILL REQUIRE TRIMMING DO NOT TRIM OR FIX DOWN until instructed to do so.**
- Position both pairs of outer bearers (step E1 &E2) so they sit level with the outer face of the half log (fig 49)and 5mm in on the side logs.
- Mark the centre of the bearer on each half log as before.



Fig 49

- Line all the remaining bearers with their centre marks , central to their angled notch or central to the end of the **N1 & G** logs.

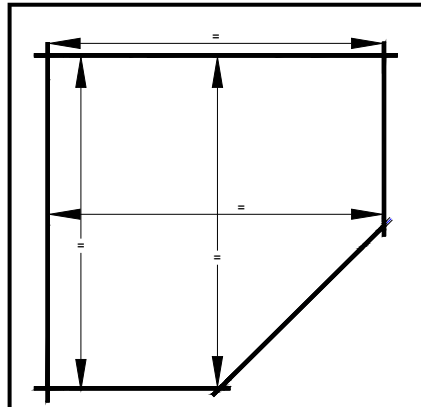

Fig 49

- Measure along the parallel walls (fig 49) and between each bearer to **ensure everything is square and true.** **ALSO measure small room**
- The position of the shaded bearers (drawing page 1) are critical. As you can see the edge of the OSB sheets (only sheet **FC** is shown on page 1 for clarity) rest on the centre of one of the bearers (**note there may be a gap of up to 6mm around floor edge –under the skirting**). Use one of the **FC** and **FA** Pieces to check that the bearer is correctly positioned.
- Once you are happy with all the positions cut notches out of the tongues on the half logs (fig 50 & 51) at centre marks (previous steps) and drill through for fixing to the bearers .The notch on the **E1** log should go out the end of the log (fig54).
- Important** Re measure as in step 16, as building must be square before fixing logs **A1 & Q1** to the joists with 1x 80mm screw (fig 50, 51 &52) at each bearer at each end **DO NOT fix at log N1 or the BEARERS THAT NEED TRIMMING YET.**
- Keep checking that everything is square as you go (step E 17)

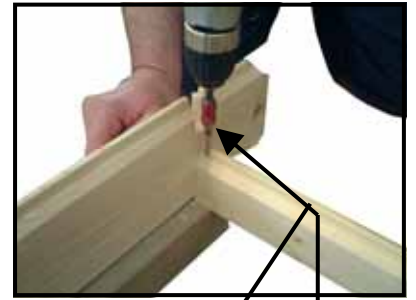

Fig 50



Fig 51



Fig 52

- Position the short double bearers and mark the length on the outside face of the **N1** log (fig 53) , slide the next log along to support the logs so you can remove them and trim to length.



Fig 53

- Re position this pair of bearers , check again that everything is square and fix as before.
- Re position the bearer that you moved mark along the face of the **N1** log as before on the remaining bearers and remove and trim to length.
- Re position the bearers and check that all is square (see next step for bearer at **N1 & G** log join) and fix as before.



Fig 54

- N1 & G log join** . This requires two 80mm screws. The first one into the bearer should be just below the surface so you have enough room to screw the second screw at an angle (fig 54) through log **N1** into log **G**.
- Check again that everything true and square and that the bearers are in the correct position for the floor sheets to fit.
- This is now ready for the walls to be built upon.

F Walls

See drawing pages & section D

1. You should have already set out the logs on each side of the building as described in section D
2. The walls can now be assembled as per drawing pages.
3. Start building walls by placing all the logs from That go on top of the half logs and then the logs that go in the opposite direction.
4. Each log needs to be tapped home to log below using timber block supplied and a rubber mallet (fig 55).

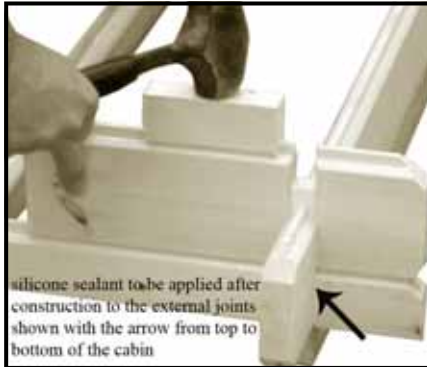

silicone sealant to be applied after construction to the external joints shown with the arrow from top to bottom of the cabin

Fig 55

5. **IMPORTANT!** Make sure you fit the door frame after a couple of layers of logs and keep count of the layers to ensure the windows are fitted at the correct height.

G Inserting windows and doors

UNDER NO CIRCUMSTANCES MUST THE DOOR OR WINDOW FRAMES BE NAILED TO THE LOGS .The logs must be free to move within the frame lots to allow for expansion and contraction. AS SOON AS YOU FIT DOOR UNIT FIT HANDLES AND UNLOCK DOOR Do not fit glass until after treatment.

1. Do not fit glass until after treatment.
2. Door unit must be placed into position after the first two layers of full logs have been assembled
3. Slide unit into aperture from above (Fig 56 & 57) ensuring unit is completely down and in position.



Fig 56 EXAMPLE



Fig 57

4. Window units are fitted (fig 58) when you have built up to the correct height



Fig 58 example

5. **Note Door and window units do not require fixing to the logs**
6. Once the door and window units are in place continue assembling the walls as before but slide the logs into the door or window frame (fig 59) from above then tap them down.



Fig 59

7. Continue building until you get to the height were the gable starts. **Do not fix the N2 YET.**



Fig 60

8. Drill through the **N3** log and screw into the **N** log with 2x 80mm screws (fig 60) **not within 20mm of the join** (see next step).**Do not fix the N2 YET.**



Fig 61

9. Make sure that the top face of the **N3** log is level with the bottom of the **G log tongue** (fig 61 inset).
10. Drill through the **N3** log at an angle (fig 61) and screw into the **G** log with 1 x 80mm screw.
11. When you remove the door frame to paint ,drill upwards through the **G2** log and fix with 2x 80mm screws. (see drawing page 2)

H Gable

See drawing pages

1. Assemble the gable as with the walls.(2 on building with storeroom)
2. Once gables are in place knock down all the walls again as in fig 11 to ensure all the walls are fully home
3. Fix the gable with 1x80mm screw at each end (fig 62.) and as shown on drawing page 6



Fig 62

I Roof Sheets

SEE DRAWING SHEETS

1. The roof panels are fitted in the order they are numbered on the drawing . **Building with storeroom start at the partition and work as below towards the angled doors then work backwards. (after step 20)**
2. Each panel will be numbered .



Fig 62

3. The gable has a w shaped cut out in it .Position panels **1 & 2** over the gable so the framework rests into the W shaped slot (fig 64) and a cut out in the framework to clear the gable (fig 62).



Fig 63

4. Ensure that both panels are flush with each other drill through one panel only at the ridge (high point) keeping the panels tight together fix with 2x60mm screws (fig 63).



Fig 64

5. Outside of building (and partition wall) -Measure 95mm (level with the return at the bottom- the return is the part of the log joint that sticks out of the building) and all the way up to the ridge (fig 64) to ensure everything is square and fix with 1x 60mm screw per panel (fig 65)



Fig 65

6. From above , measure 109mm from the edge of the roof panel mark and fix the roof panel to the gable with 3x60mm screws per panel.



Fig 66

7. The bottom of the panels framework should sit snug against the side walls. (fig 67)



Fig 67



Fig 68

8. From the outside drill through the log and fix with 1 x 60mm screw (fig 68)
9. Place the back roof panel 3 next to the panels already fitted , pre drill and fix with 3x80mm screws **ensuring that the panels are flush and true to each other and the walls** (fig 68) .



Fig 69

10. You will need to mark and trim the roof line on the top log returns (corners that stick out , fig 70 & 71) at the corners of the door walls before fitting each of the remaining roof panels **except panel 4** .
11. The amount you trim need not be exact as it is not structural and is hidden behind the fascias.
12. You can always take less off, try the position and then trim or plane some more if needed.



Fig 70

13. To get the roof line on the return place the other roof panel 3 upside down overlapping roof panel 1 (you will need help to support the panel) and slide it up to the return.
14. Mark its position with a pencil and use a knocking block straight edge (fig 70) to continue the guide line and then saw off the excess (fig 71) .



Fig 71

15. Position panel 3 as before **ensuring that the panels are flush and true to each other and the walls** pre drill and fix with 3x80mm screws to panel 2 and 2x60mm at the ridge as in step 4.
16. Position panel 4 as before **ensuring that the panels are flush and true to each other and the walls** (fig 72), the frame work must fit snugly next to the corner and fix with 3x80mm screws .



Fig 72

17. Position panel 5 upside down and mark the return and trim as before.
18. Position panel 5 the correct way up **ensuring that the panels are flush and true to each other and the walls** (fig 73) ,the framework should sit in the corner and fix with 4x80mm screws. Angle the top screw as shown.



Fig 73

20. Repeat the previous steps with panels 6&7 fix with 3x80mmscrews at each join.
21. **Building with storeroom** Repeat the previous steps with remaining panels working backwards fix with 3x80mmscrews at each join.

J Roof Edgings

1. Fix the 44mmx44mm roof edging (fig 74) as shown with 4x40mm screws per edging., long back edging 6x40mm. **Note** there will be gaps between the edgings at this stage that will be covered later .



Fig 74

K Tile roof

1. Packs of shaped tiles and strips rectangular tiles for the eaves and ridge have Packs of shaped tiles which are used for the slope, eaves (low edge)and ridge (top point) have been supplied. (SEE CONTENTS)
2. Use tiles randomly from the packs of tiles supplied to even out the colour match. **REMOVE BACKING FROM All TILES**
3. **remove all dust and sharp edges from the roof boards.**

If you are fitting your own guttering fit it now so you can over lap the eaves tiles into the gutter.

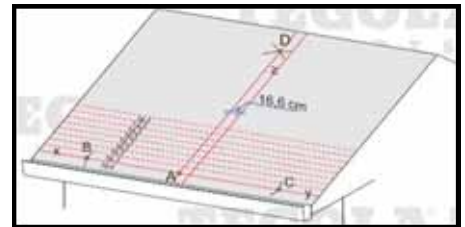

Fig H1

5. Mark a line xy orthogonal to the direction of maximum slope of the roof (usually parallel to the eaves and to the ridge and at 18.4 cm from the eaves to give a 1 cm drip edge) ;
6. Mark along the line xy a point A in the centre of the pitch ;
7. Mark points B e C, at either side from A (for example at 150 cm);
8. Starting from B and C by using a chalk line as a compass, mark point D as near as possible to the Ridge.
9. Join A with D;
10. Mark a line parallel to line AD at a distance of 16.6 cm (z);
11. Starting from the line xy, mark horizontal and parallel lines to the line xy, at a distance of 14,3 cm from each other up to the ridge (Fig H 11)



Fig H2

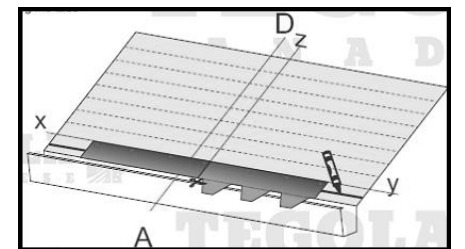

Fig H3

12. rim the tabs from the bituminous shingle, remove the protection film to form the starter course (Fig H2 & 3)
13. Align it to the line z & xy (Fig H3).
14. Remove the protection film from the reverse side of each shingle before installation.

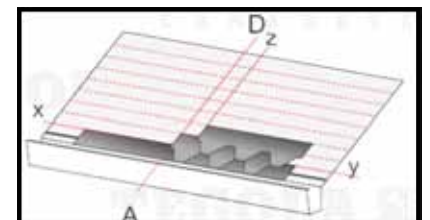

Fig H4

15. Install the first row of shingles along the line AD (Fig H4).



Fig H5

16. Apply 6 nails on each bituminous shingle , positioned exactly as shown in fig 5

17. Make sure that the nails anchor also the underneath bituminous shingle. Install the second row of shingles along the line z (Fig H 4)
18. Repeat this installation method until all pitches are completed
19. The trimming and aligning operations are simplified following the cuts on the upper edge of each bituminous shingle.

RIDGE

20. Install the last row of bituminous shingles up to the ridge line and then bend it over the exceeding part, in order to waterproof the ridge .
21. To obtain the ridges, cut the bituminous shingles into 3 pieces (Fig H 6). Before installing remove the rivers side protection film, bend the piece of shingle and position them over the ridge line (see Picture
22. If necessary heat them on the reverse, sanded side.
23. Fix the ridges with 2 nails on each piece which will be overlapped by the following piece (Fig H7).

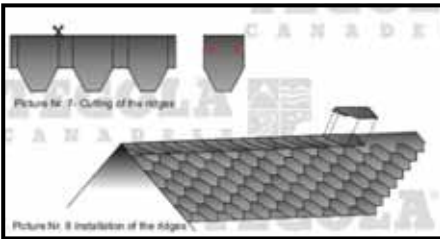

Fig H7

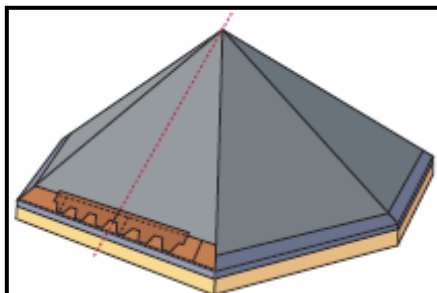

Fig H8

19. Hexagonal roofs (barbecue shelters, conical huts etc.)With shingles it is practical to mark out the centre line for each triangular section from the eave to the ridge point. The centre butt joint of first shingle row should be in line with the centre marking line. Thereafter the centre butt joint of every second row should be in line with the marking line. In this way, the pattern will be identical on all triangular sections.
20. The roof is covered one triangular section at a time, in a way similar to the roofing of the
21. hipped ends of hipped roofs. Ridge capping shingles are installed over the hips.

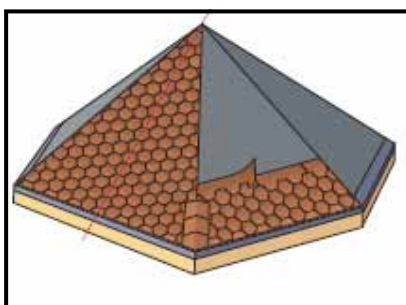

Fig H9

L Fascia & Diamond

1. Fascia boards can now be drilled and screwed (fig 90) with 3x 50mm screw at each roof panel and 1x 50mm screw at the roof edgings.



Fig 90

2. Drill diamond and screw with 2x50mm screws . (fig 91)

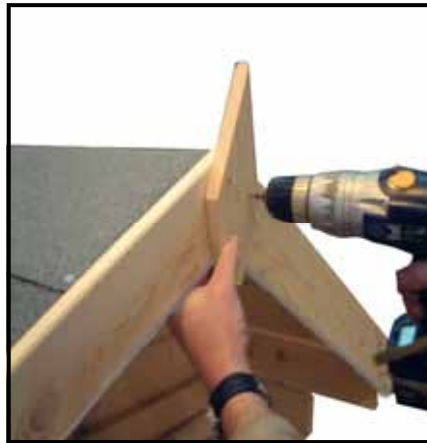

Fig 91

3. Fix the eaves fascias over the doors first . Even out the side overhang and fix with 4x40mm screws . (fig 92)



Fig 92 example

4. Next place one of the window fascias (one is longer than the other so measure and check which is which) behind the door fascia use a small block to mark the angle of the front fascia on the end of it and trim then fix with 3x40mm screws .
5. Repeat with the other fascia.
6. The plain back has no fascia.

M Floor & Skirting

See drawing pages 1 & 1a

IMPORTANT NOTES

1. Do not stand on untreated panels as dirt may be hard to remove.
2. There may be an expansion gap (up to 6mm) left between the OSB floor sheets and the walls.
3. It may also be necessary to slightly trim the panels to get the best fit.
4. Before fixing it is recommended that you lay the sheets into position to familiarise yourself with the layout.
5. The floor is fitted (main room) working from the corner sheet FA Make sure that the sheet is positioned centrally on the joist where it butts up to sheet FC
6. Mark the joist centres on the edge of floor sheet . Fix with 40mm nails at 4 per joist. You can use a piece of skirting as a guide to keep the nails in line (fig 93)



Fig 93

8. Slide the edge sheet FB under the doorframe (fig 94) . Align it as before and fix with 40mm nails at 4per joist.



Fig 94

9. Position and fix the remaining floor sheets (FC x2 , FD and then FE) in order as before.
10. Lay out all the skirting boards around the walls and Cut to suit and fix with 40mm oval nails at approx 400mm centres (fig 94). Repeat with storeroom.



Fig 95 example

N Glazing  Danger of cutting use gloves etc.

After painting

1. NOTE ensure that you have treated the beading and the rebate where the glass fits before fixing the glazing.
2. Place glazing material into the aperture of each window.
3. Hold into position with four pieces of beading . The beading may need to be swapped around to get the best fit. When satisfied secure into position using 2x15mm panel pins per piece of beading. (fig 96)Repeat for all window and door apertures.



Fig 96



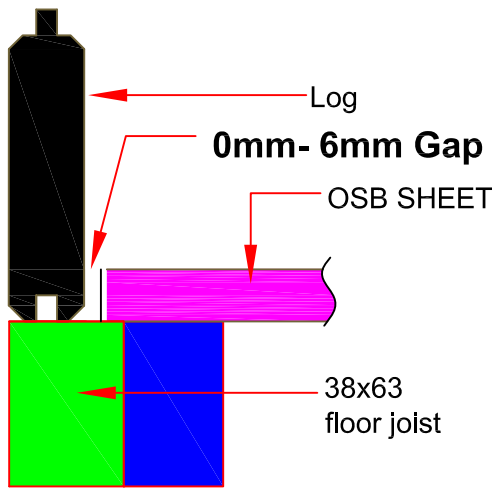

2960x4340

Leygrove

FLOOR PLAN

Reference for base

Detail showing
Log on joist
OSB floorboard on joist

Back and front views/walls

see page 5,7,8&10 for bearer spacing

fig 1

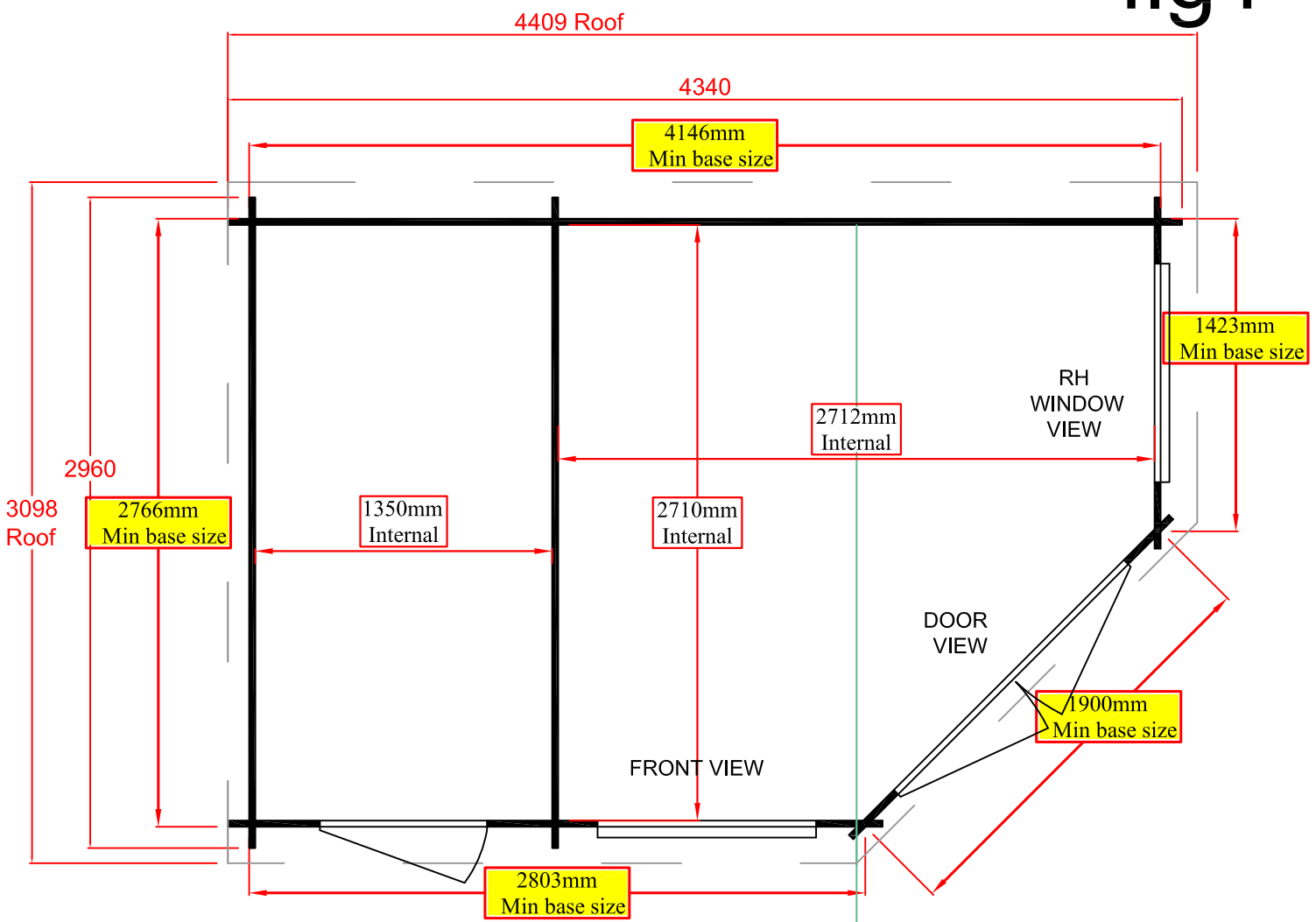

SHIRE

BUILT AROUND OUR REPUTATION

page 2

see page 5,7,8&10 for bearer spacing

2960x4340

Leygrove

FLOOR BEARERS

38x63 pressure treated

9x2900

4x1869

7x1250

7 joiners approx 1m

Floor bearer spacing see
instructions and pages

5,7,8&10

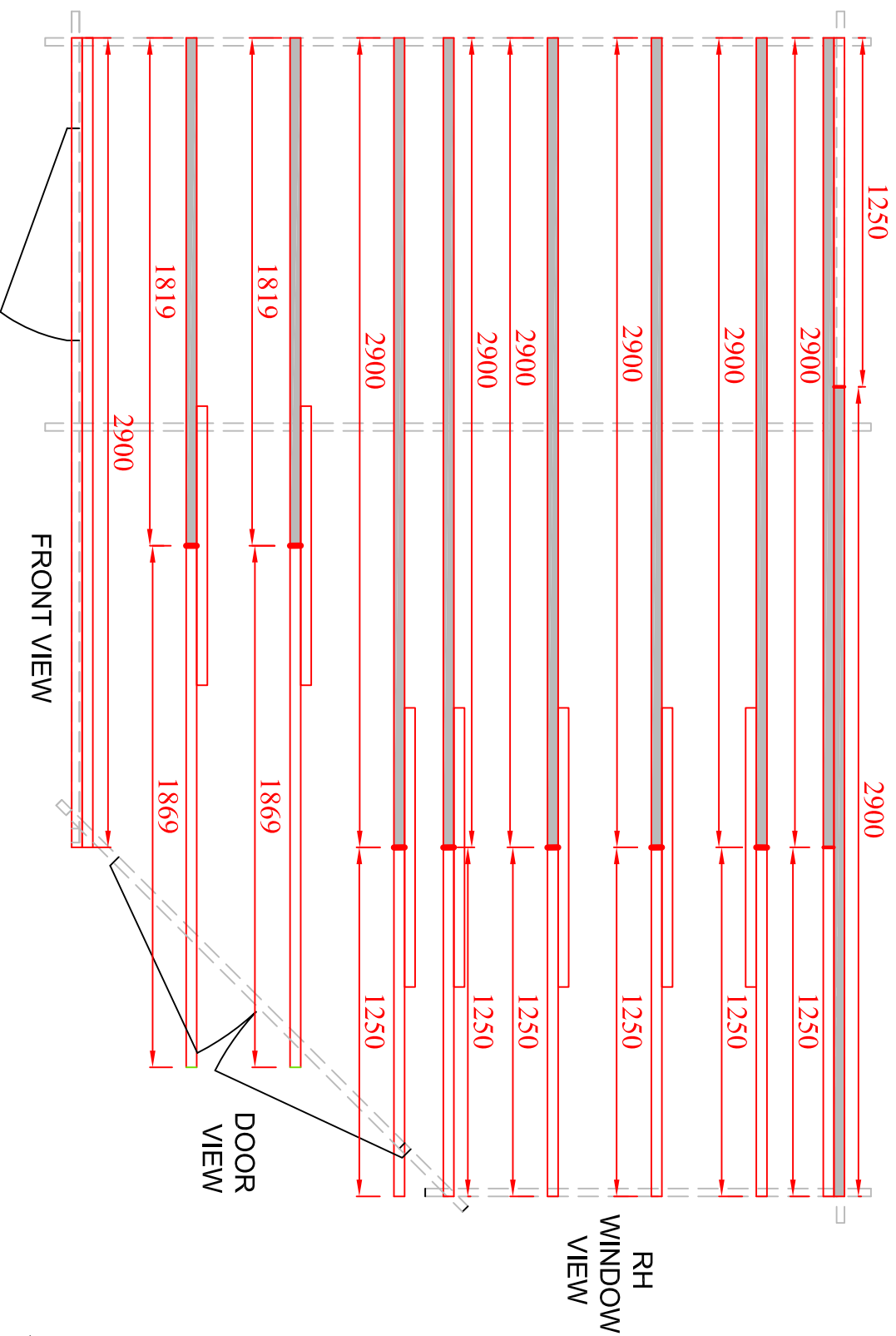

RH
WINDOW
VIEW

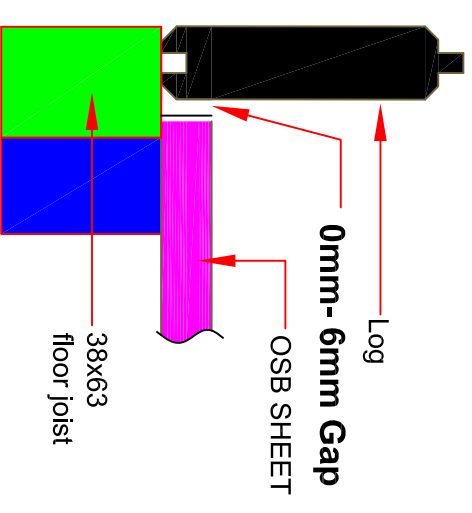

Detail showing

Log on joist

OSB floorboard on joist

Back and front views/walls

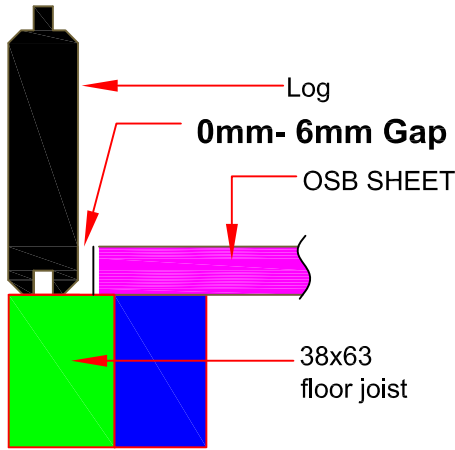

Detail showing
Log on joist
OSB floorboard on joist
Back and front views/walls

2960x4340
Leygrove
FLOOR PLAN
PRESSURE TREATED
FLOOR JOISTS 38x63
9x2900
4x1869
7x12507
joiners approx 1m

Floor bearer spacing see
instructions and pages
5,7,8&10

OSB floor sheets
see instructions
& page 4

see page 5,7,8&10 for bearer spacing

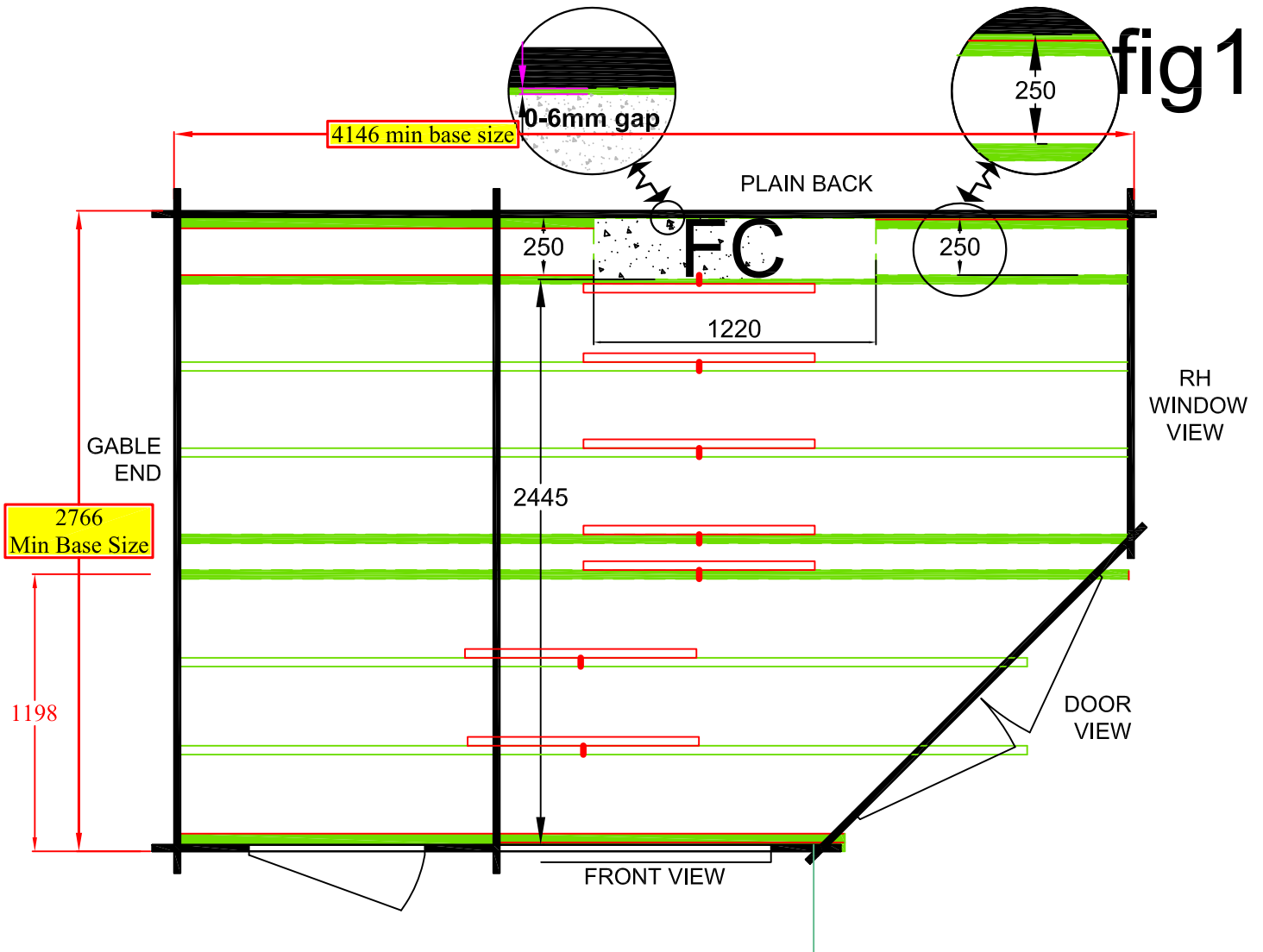

see page 5,7,8&10 for bearer spacing

SHIRE

BUILT AROUND OUR REPUTATION

page 4

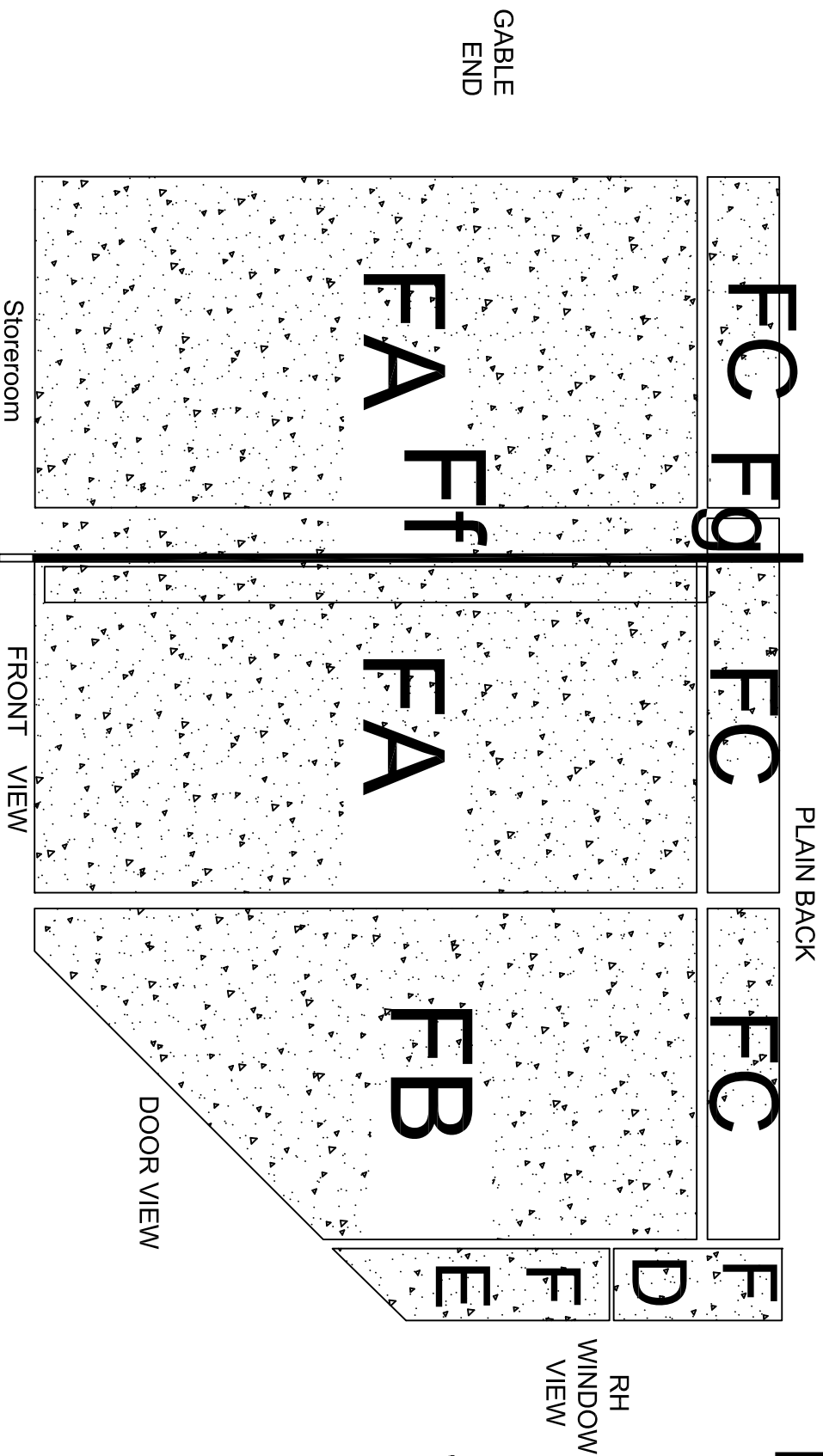

GABLE
END

RH
WINDOW
VIEW

up to 6mm Expansion gap
all around the floor edge
sheets may need
trimming

FLOOR SHEETS
Fit these sheets last

2960x4340
Leygrove

F x 17

G x 20

N x 1

N1 x 1

N2 x 1

N3 x 1

80mm screws see section G 8-11 T

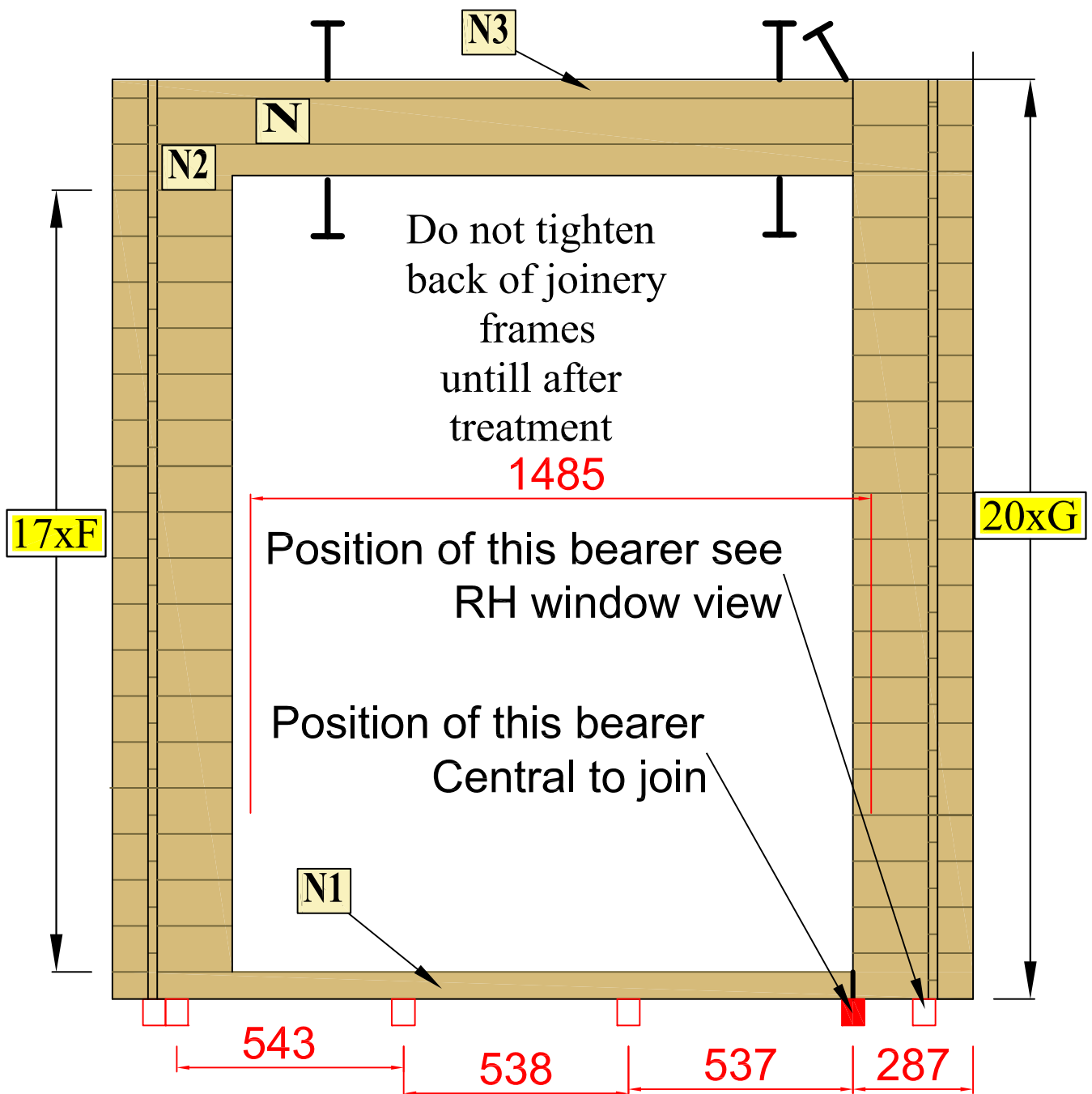

BEARER CENTRES

2960x4340

Leygrove

FRONT

Parts list

G x 11

L x 16

M x 11

O x 2

O1 x 1

O2 x 1

P x 4

P1 x 1

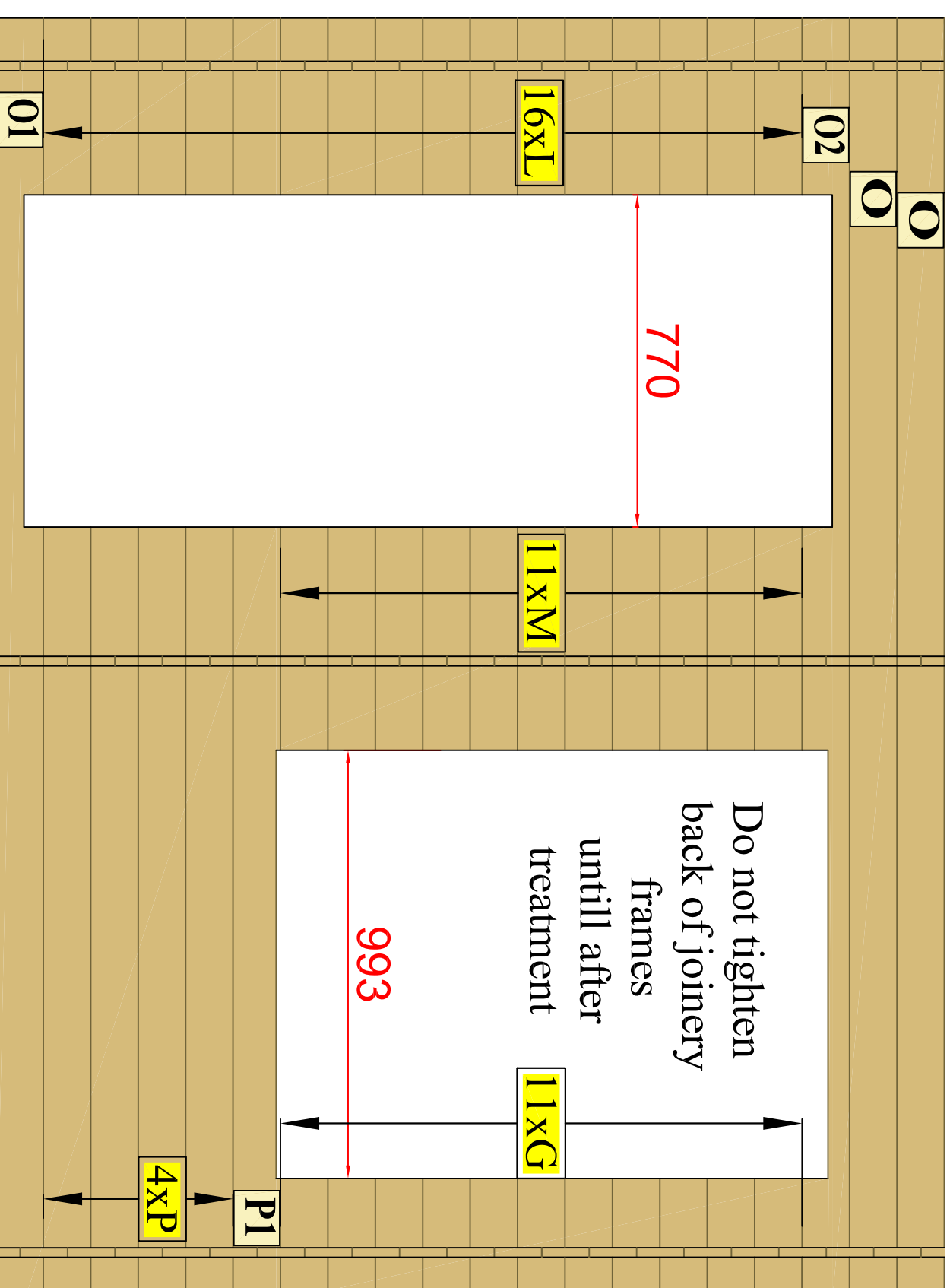

2960x4340

Leygrove

RH WINDOW View

PARTS LIST

C x 11

F x 11

Q x 7

Q1 x 1

Q2 x 1

Q3 x 1

SHIRE

BUILT AROUND OUR REPUTATION

page 7

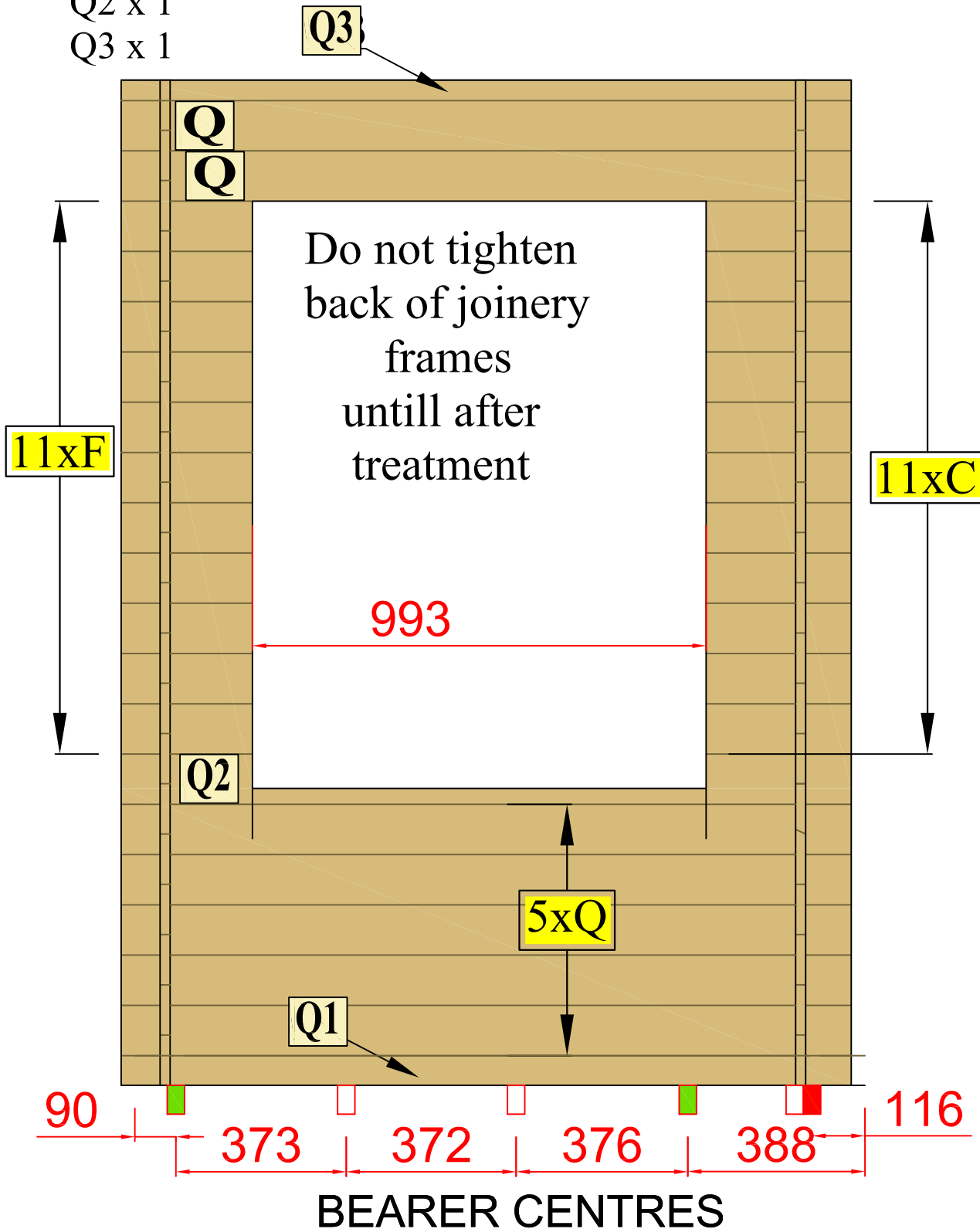

2960x4340

Leygrove

Partition

Parts list

A x 18

A1 x 1

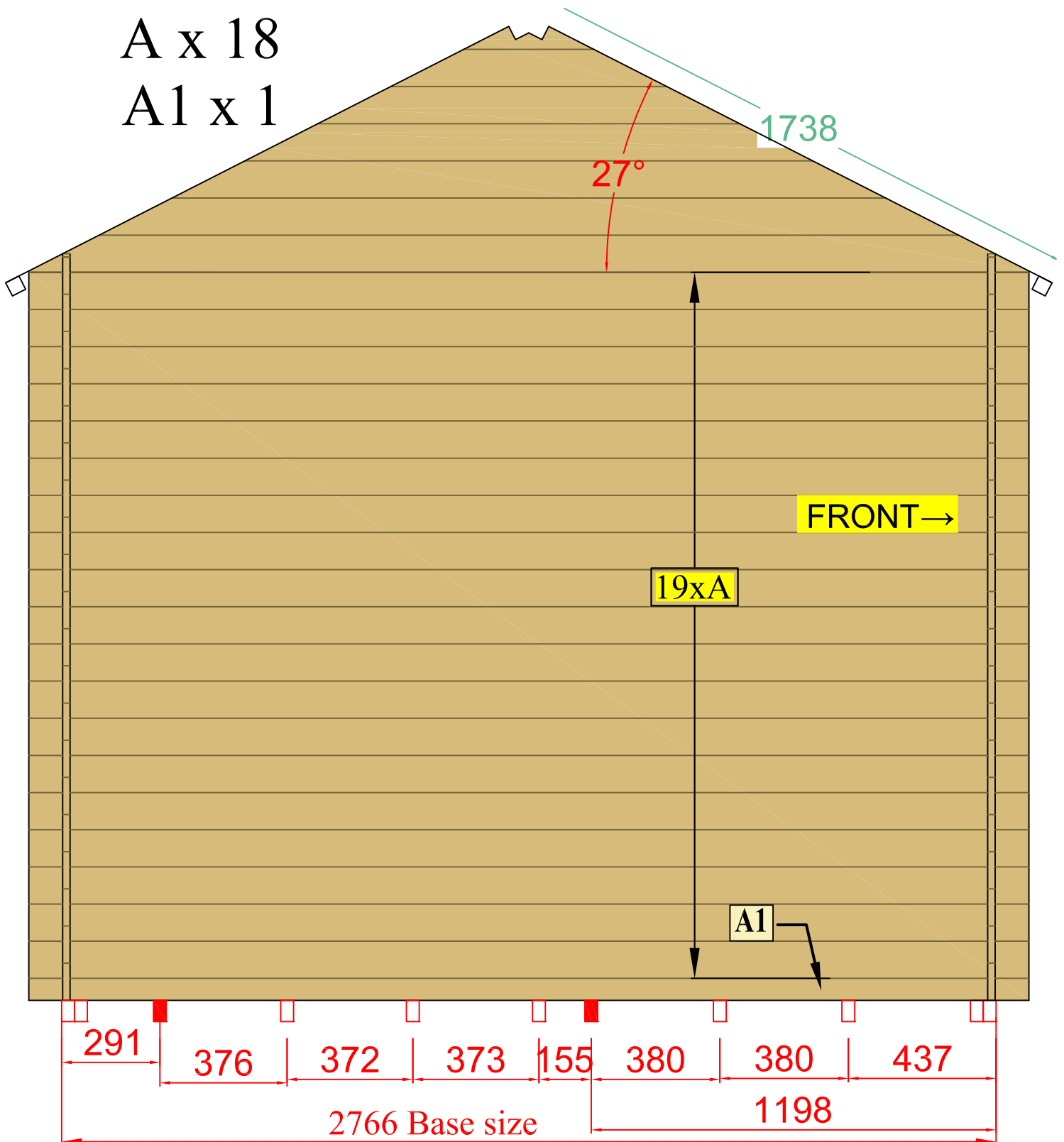

BEARER CENTRES

2960x4340

Leygrove

PLAIN BACK VIEW

PARTS LIST

I x 20

SHIRE

BUILT AROUND OUR REPUTATION

page 9

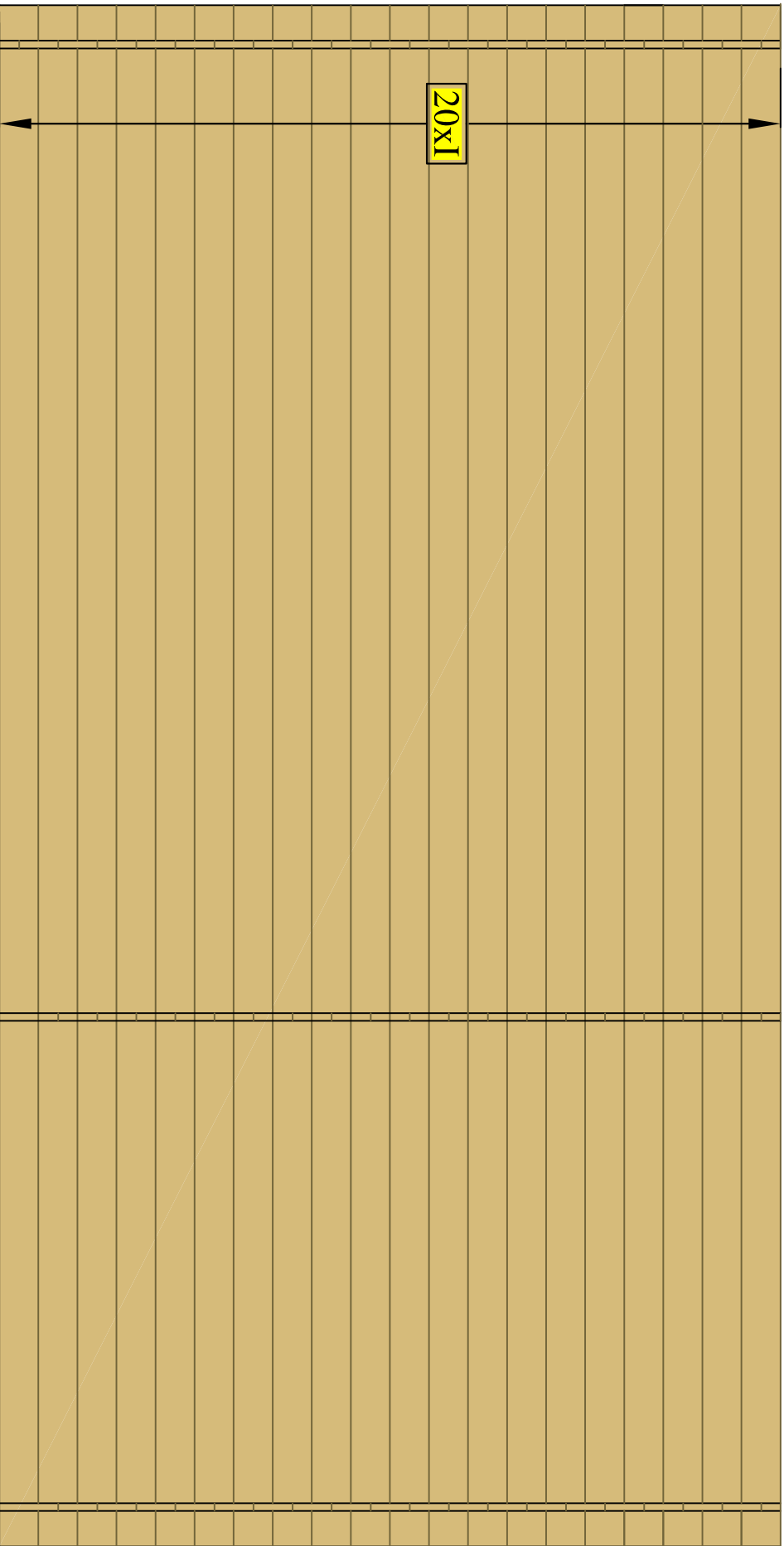

2960x4340
Leygrove
GABLE END
PARTS LIST
A x18
A1x1

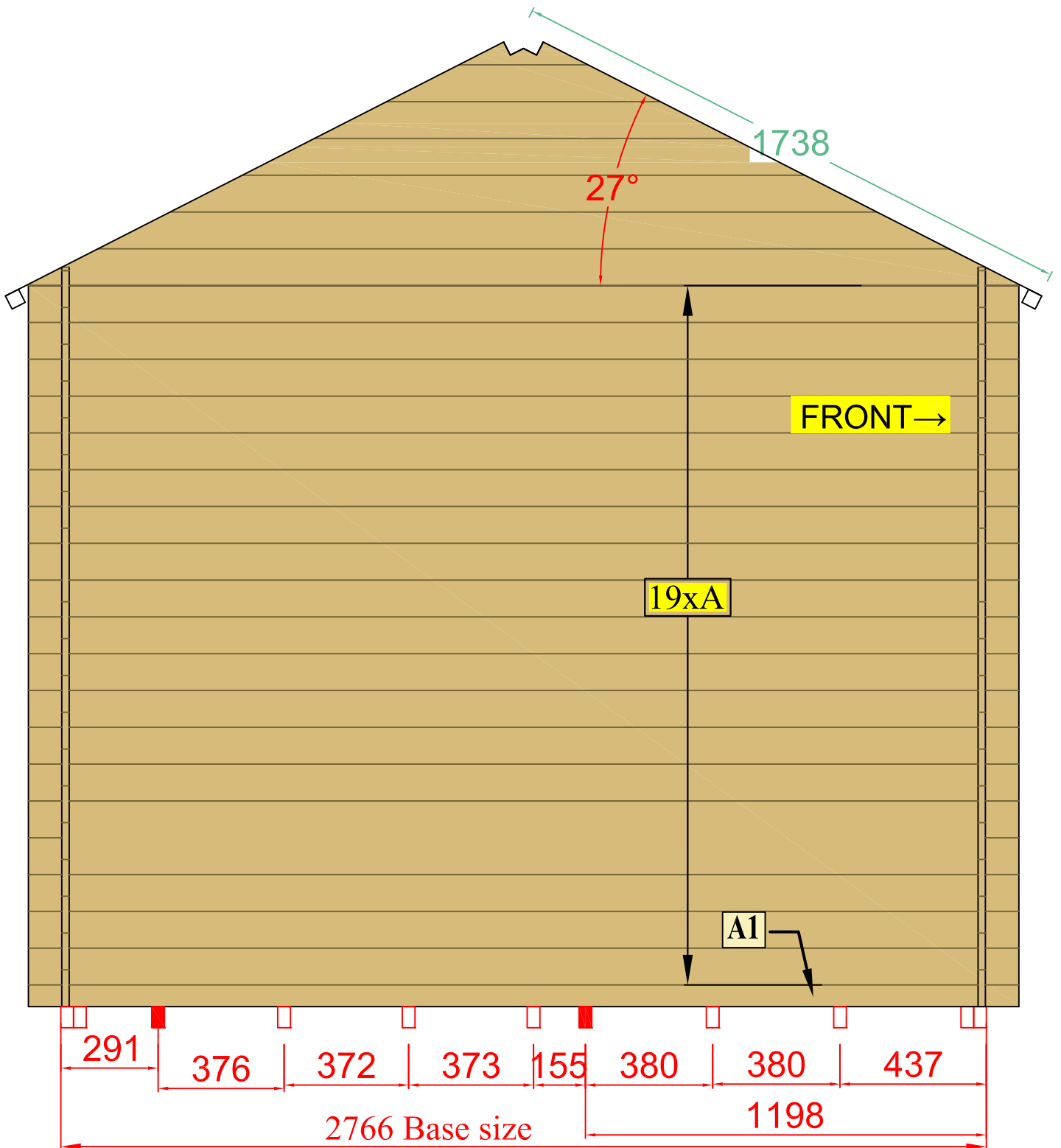

PLAIN BACK

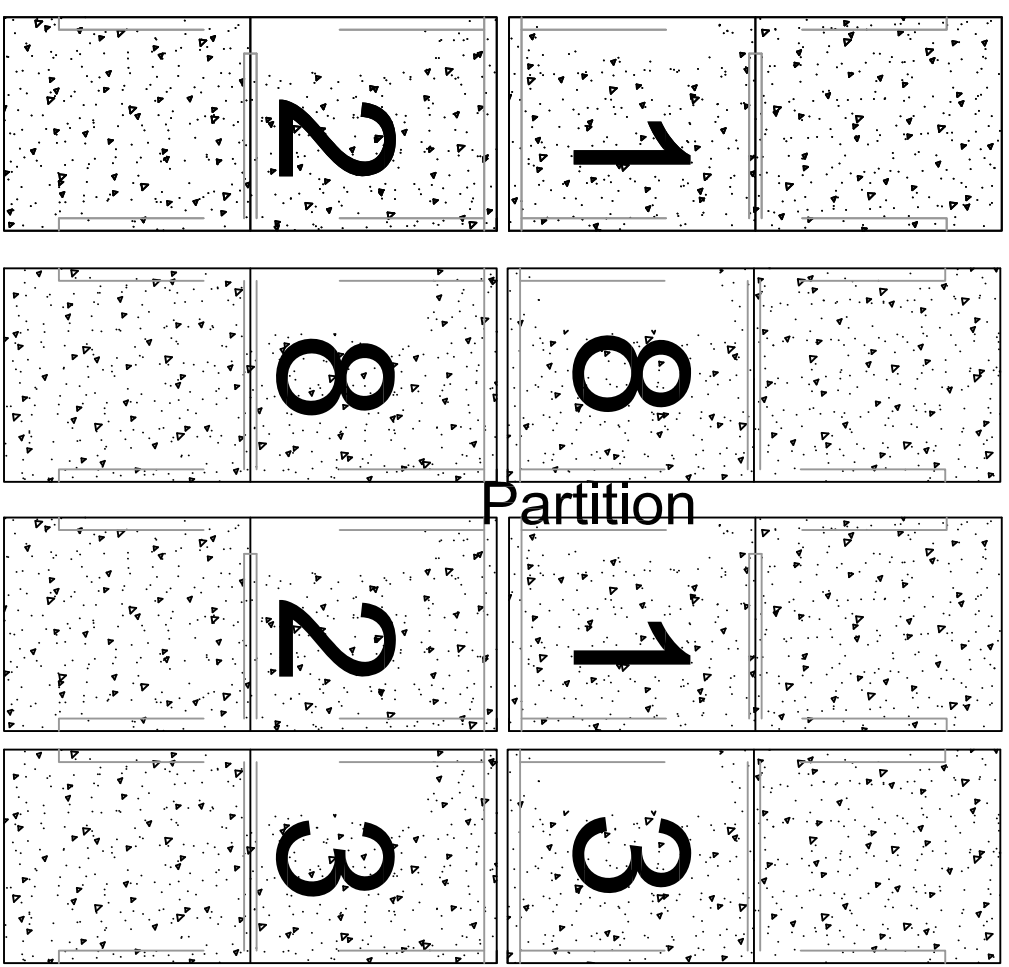

GABLE
END

Partition

FRONT VIEW

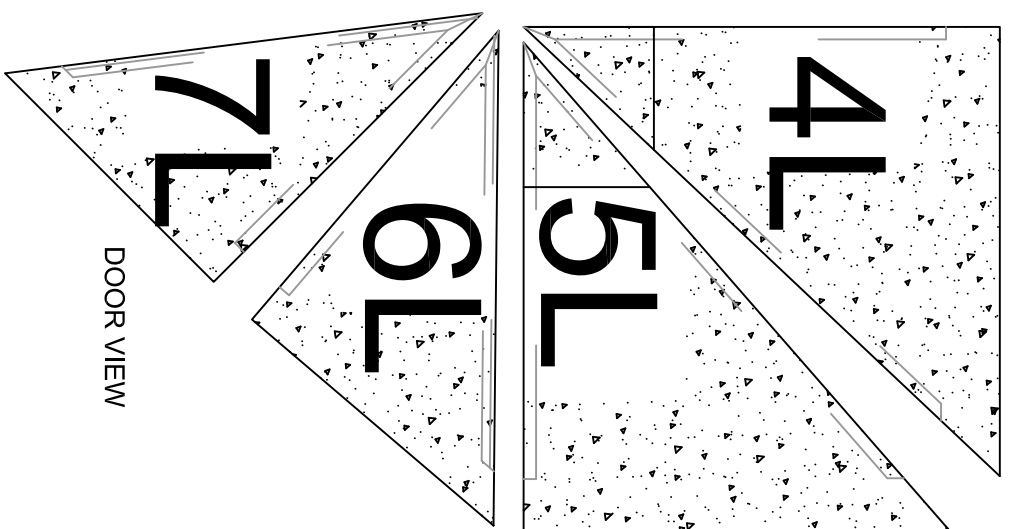

RH
WINDOW
VIEW

2960X4340

Leygrove

ROOF SHEETS

DOOR VIEW