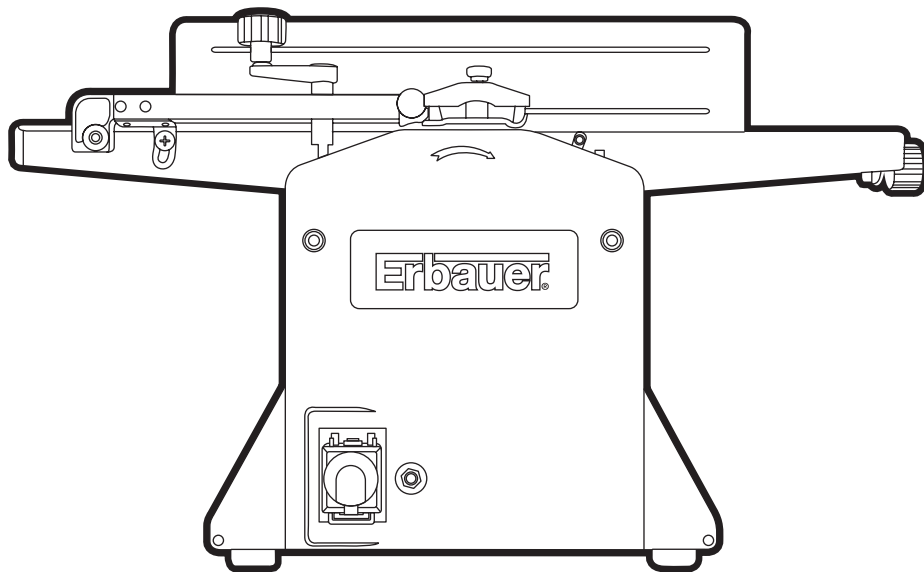




# Erbauer®



**ERB052BTE**

**2** WARRANTY  
**YEARS**

**8" THICKNESS PLANER**





# Erbauer®

**Congratulations on your purchase of a quality power tool from Erbauer (UK) Ltd. This product should give you reliable service but for your peace of mind this **Erbauer** power tool does carries a 24-month guarantee, the terms of which are detailed below.**

**If this product develops a fault within the guarantee period contact your retailer.**

**Please retain this handbook in case you need to refer to safety, care or guarantee information in the future.**

## **GUARANTEE**

This **Erbauer** product carries a guarantee of 24 months. If your product develops a fault within this period, you should in the first instance contact the retailer where the item was purchased.

This guarantee specifically excludes losses caused due to:

- Fair wear and tear
- Misuse or abuse
- Lack of routine maintenance
- Failure of consumable items (such as batteries)
- Accidental damage
- Cosmetic damage
- Failure to follow manufacturer's guidelines
- Loss of use of the goods

This guarantee does not affect your statutory rights. This guarantee is only valid in the UK.

For further technical advice, spare parts or repair service (outside of guarantee) please contact the customer helpline number on 0845 607 6380





## SAFETY INSTRUCTIONS



**Warning!** When using electric tool, the following basic safety precautions should always be taken to reduce the risk of fire, electric shock and personal injury. Read all these instructions before attempting to operate the product and save these instructions for future reference.

### SAVE THESE INSTRUCTIONS

#### 1. Keep the work area clean.

Cluttered areas and benches invite injuries.

#### 2. Consider work area environment.

Do not expose power tools to rain. Do not use power tools in damp or wet locations. Keep the work area well lit. Do not use tools in the presence of flammable liquids or gases.

#### 3. Guard against electric shock.

Avoid body contact with earthed or grounded surfaces (e.g. pipes, radiators, ranges, refrigerators).

#### 4. Keep children away.

Do not let persons, especially children, not involved in the work touch the tool or the extension cord and keep them away from the work area.

#### 5. Store idle tools.

When not in use, tools should be stored in a dry, high or locked up place, out of reach of children.

#### 6. Do not force the tool.

It will do the job better and safer at the rate for which it was intended.

#### 7. Use the right tool.

Do not force small tools to do the job of a heavy-duty tool. Do not use tools for purposes not intended, for example, do not use circular saws to cut tree limbs or logs.

#### 8. Dress properly.

Do not wear loose clothing or jewellery, they can be caught in moving parts. Non-skid footwear are recommended when working outdoors. Wear protective hair covering to contain long hair.

#### 9. Use protective equipment.

Use safety glasses. Use face or dust mask if working operations create dust.

#### 10. Connect dust extraction equipment.

If the tool is provided for the connection of dust extraction and collecting equipment, ensure these are connected and properly used.

#### 11. Do not abuse the cord.

Never yank the tool to disconnect it from the socket. Keep the cord away from heat, oil and sharp edges.

#### 12. Secure work.

Where possible use clamps or a vice to hold the work. It is safer than using your hand.

#### 13. Do not overreach.

Keep proper footing and balance at all times.

#### 14. Maintain tool with care.

Keep cutting tools sharp and clean for better and safer performance. Follow instructions for lubrication and changing accessories. Inspect tool cord periodically and if damaged have them replaced by an authorised service facility. Inspect extension cords periodically and replace if damaged. Keep handles dry, clean and free of oil or grease.

# 8" THICKNESS PLANER





### **15. Disconnect tools.**

When not in use, before servicing and when changing accessories such as blades, bits and cutters, disconnect tools from the power supply.

### **16. Remove adjusting keys and wrenches.**

From the habit of checking to see that keys and adjusting wrenches are removed from the tool before turning it on.

### **17. Avoid unintentional starting.**

Ensure switch is in the "off" when plugging in.

### **18. Use outdoor extension leads.**

When tool is used outdoors, use only extension cords intended for outdoor use and so marked.

### **19. Stay alert.**

Watch what you are doing. Use common sense. Do not operate tool when you are tired.

### **20. Check damaged parts.**

Before further use of the tool, it should be carefully checked to determine that it will operate properly and perform its intended function. Check for alignment of moving parts, binding of moving parts, breakage of parts, mounting and any other conditions that may affect its operation. A guard or other part that is damaged should be properly repaired or replaced by an authorised service centre unless otherwise indicated in this instruction manual. Have defective switches replaced by an authorised service facility. Do not use the tool if the switch does not turn it on and off.



### **21. Warning.**

The using of any accessory or attachment other than those recommended in this instruction manual may present a risk of personal injury.

### **22. Have your tools repaired by qualified person.**

This electrical tool complies with the relevant safety requirements. Repairs should only be carried out by qualified persons using original spare parts, otherwise this may result in considerable danger to the user.



## HEALTH ADVICE



**Warning!** When drilling, sanding, sawing or grinding, dust particles will be produced. In some instances, depending on the materials you are working with, this dust can be particularly harmful to you (e.g. lead from old gloss paint). You are advised to consider the risks associated with the materials you are working with and to reduce the risk of exposure. You should:

- Work in a well-ventilated area.
- Work with approved safety equipment, such as those dust masks that are specially designed to filter microscopic particles.

## SPECIFIC SAFETY INSTRUCTIONS



**Caution!** If used incorrectly, woodworking machines can be dangerous, for this reason always comply with the safety instructions mentioned in this manual.

1. Never work without the protective equipment prescribed for the relevant operation and do not make any modifications to the machine that could undermine safety.
2. Children and young persons must not operate this machine. This rule does not apply to young persons over the age of 16 being trained and supervised by an expert.
3. Prior to all work, make sure that the safety and operating equipment is securely attached. Any parts, if damaged must be repaired correctly or replaced.
4. Set up the machine on a firm flat surface so that the table is horizontal and the machine cannot tip over.
5. Never work with pieces which are too big or too small for the machine's capacity.
6. Before planing, examine the workpiece for metal objects and stones and remove them if necessary.
7. When planing, make sure that the portion of the cutter head not being used is covered by the cutter guard.
8. When planing thin pieces of timber, suitable devices must be used to ensure that these small pieces are properly positioned and guided.
9. The anti-kickback device of the planer must be checked regularly to ensure that it remains in proper working condition. All pawls of this device must move freely and must drop down by their own weight when lifted. The point of these pawls must be kept sharp.
10. Do not begin planing until the cutter head has reached full speed.
11. When planing, take up a working position so that you are always on one side of the machine away from the area directly in front of or behind the cutter head.
12. Always keep your hands well away from the cutter head or the chip ejection area while the machine is running.
13. A uniform feed rate when planing increases the life of the cutting blades and reduces the risk of accidents.
14. The planing blades must be sharpened or replaced in good time as blunt knives do not only increase the risk of kickback, but also impose an unnecessary load on the motor.
15. The sawdust created by planing can make it difficult to see as clearly as necessary and can impair the operator's health in certain circumstances.
16. If not working outdoors or in a well ventilated area, the machine should ideally be connected to an extractor unit with an air velocity of at least 20 m/s (65.6 ft/sec.).
17. The sound pressure level at the workplace generally exceeds 85 dB (A), Users should


# 8" THICKNESS PLANER





- therefore wear ear protectors.
18. Any repairs to the planer thicknesser must be carried out only by a suitably qualified person.
  19. Only original spare parts and accessories must be used. Otherwise the manufacturer does not offer any warranty and does not accept any liability for personal injury.
  20. Regular cleaning of the machine is an important safety factor, before beginning this task always ensure the planer is turned off and that the plug is removed from the mains supply.

## **ADDITIONAL SAFETY INSTRUCTIONS FOR PLANER THICKNESSERS**

 **Warning!** Before connecting the tool to the mains supply be sure that the voltage supply is the same as that specified on the nameplate of the tool. A power source with a voltage greater or lower than that specified for the tool can result in serious injury to the user, as well as damage to the tool. If in doubt, do not plug the tool into the mains supply. Always turn the machine off and remove the plug from the mains socket before making any adjustments or maintenance, including changing the blades.

1. When an extension cable is required, you must ensure that it has the right ampere rating and a large enough cross section for the planer thicknesser, it should also be checked to make sure that no damage is present and it is in safe electrical condition.
2. Ensure that you have removed foreign objects such as nails and screws from the work before commencing.
3. Rags, cloths, cord, string and anything that could get "dragged" into the cutter block should be removed from the work area prior to use.
4. Damaged or contaminated work pieces may cause unwanted hazards. Metal parts penetrated into the workpiece can be very dangerous, and should be removed before operation starts.
5. Use safety equipment including safety goggles or shield, ear protection, dust mask and protective clothing.
6. Check to make sure that all fixing screws are tight before operating the tool.
7. Ensure that the dust extractor is in place before commencing operation.
8. Do not force the workpiece through the machine, let the machine apply the correct automatic feed rate.
9. Keep the feed rollers free of wood chips and sawdust, if the movement becomes clogged, kickback can occur.
10. The machine is designed for the planing of wood only. Never to cut recesses, tenons or moulds.
11. Do not use the machine for planing wood with numerous knots or loose knots.
12. Do not stand directly in front of the machine during operation, stand to one side.
13. Check that the blades are fitted correctly before commencing operation.
14. Take care when handling blades and the cutter head. Wear work gloves. The blades are sharp and can easily cut bare hands.
15. Allow the machine to reach full speed before feeding in a workpiece.
16. Check that the cutters are securely fastened.
17. Check the amount of cut on the blade before feeding in a workpiece.
18. Check that the cutters are securely fastened.



19. Check the amount of cut on the blade before using the machine.
20. Never attempt a heavy cut in short stock.
21. Avoid cutting across the grain.
22. Use the push pads to keep your hands well away from the blades, particularly for shorter stick planing. Do not attempt to feed work pieces that are shorter than the minimum length specified in the technical data of the tool.
23. Advance the material to the cutting head for normal operation by sliding it along the table, never by placing it directly on the cutting head.
24. Never leave the machine set to a heavy cut, always reduce it to a minimum cut.
25. Use cutting blades designed for this machine only.
26. Rectify the faults including guards and cutter block immediately as they are discovered.

## SYMBOLS



Read the manual



Warning



Wear gloves

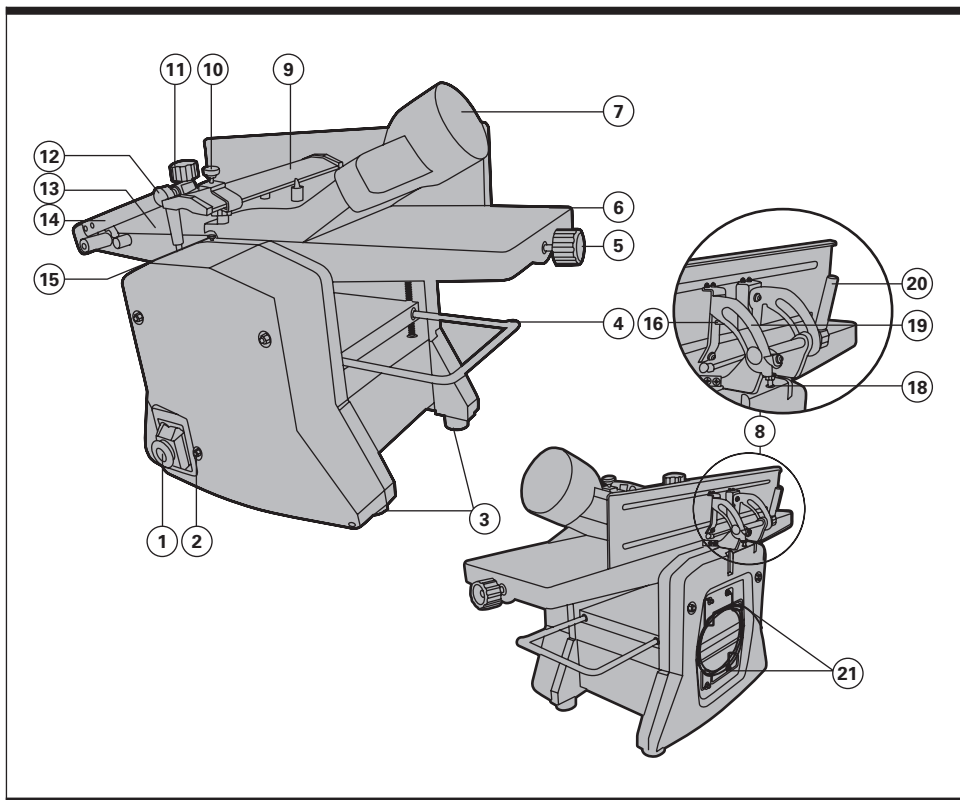


Wear dust mask, eye & ear protection



Conforms to relevant safety standards

# 8" THICKNESS PLANER



**1. ON/OFF (NVR) SWITCH**

**2. MOTOR OVERLOAD SWITCH**

**3. RUBBER (ANTI VIBRATION) FEET**

**4. THICKNESSER EXTENSION RAIL**

**5. CUT DEPTH CONTROL KNOB (PLANER MODE)**

**6. ADJUSTABLE (IN-FEED) TABLE (PLANER MODE)**

**7. CHIP EXTRACTION OUTLET**

**8. GUIDE FENCE**

**9. BLADE (CUTTER) GUARD**

**10. BLADE GUARD LOCKING KNOB**

**11. HEIGHT ADJUSTING HANDLE (THICKNESSING MODE)**

**12. BLADE GUARD ANGLE LOCKING KNOB**







---

**13. FIXED (OUT-FEED) TABLE (PLANER MODE)**

---

**14. BLADE GUARD ARM ASSEMBLY**

---

**15. SAFETY INTERLOCK SWITCH**

---

**16. 45° FENCE ANGLE STOP**

---

**17. ANGLE POINTER**

---

**18. 90° FENCE ANGLE STOP**

---

**19. ANGLE GUIDE**

---

**20. FENCE ANGLE LOCK HANDLE**

---

**21. CABLE CLIPS**

---

---

**TECHNICAL DATA**

---

Volts:	230V~50Hz
Power:	1280W
No load speed:	8,500min <sup>-1</sup>
Max. planing width:	204mm
Max. depth of cut (planer):	3mm
Max. depth to cut (thicknesser):	2mm
Planing height:	5-120mm (Thicknesser)
Feed speed:	8m/min (Thicknesser)
Table size:	740x210mm (Planer) 250x204mm (Thicknesser)
Machine weight:	27.5kg

---

---

**NOISE AND VIBRATION DATA**

---

Sound pressure level:	92.9dB
Sound power level:	105.9dB

---

# 8" THICKNESS PLANER





## ACCESSORIES

<b>Crank</b>	<b>1pc</b>
<b>Parallel guide</b>	<b>1set</b>
<b>Dust collector</b>	<b>1pc</b>
<b>Push block</b>	<b>2pcs</b>
<b>Blade setting gauge</b>	<b>1pc</b>
<b>Hex key</b>	<b>3pcs</b>
<b>Spanner</b>	<b>1pc</b>
<b>Subassembly stand cushion</b>	<b>1set</b>
<b>Safety guard plate</b>	<b>1pc</b>





## ASSEMBLY

### 1. Fitting the rubber (anti-vibration) feet (See Fig 1):

- 1) Carefully turn the machine upside down, taking care not to damage the in-feed / out-feed beds.
- 2) Fit the washers over the hex bolts and push both through the holes in the rubber feet.
- 3) Fit the feet / bolts to the holes provided (1 on each corner of the machine).
- 4) Secure using a 6 mm hex key.

### 2. Fitting the guide fence (8 )(See Fig 2-4):

- 1) Locate the 2 x guide fence mounting holes situated on the side of the planning out-feed table (13).
- Then place the safety guard plate. (Fig 3)
- 2) Line up the 2 x mounting holes on the guide fence (8) with those situated on the out-feed table (13).
  - 3) Fit the 2 x supplied hex head screws through both sets of holes and tighten to secure.

**Note:** Do not over-tighten the screws as this will cause un-wanted damage to the aluminium out-feed table. Rather just tighten until the fence is secured.

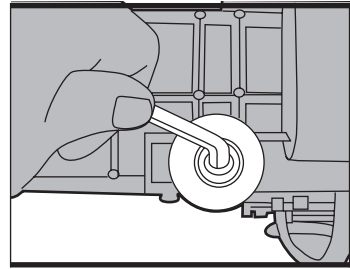


Fig 1

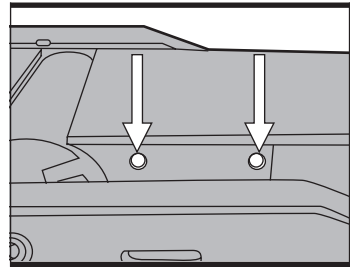


Fig 2

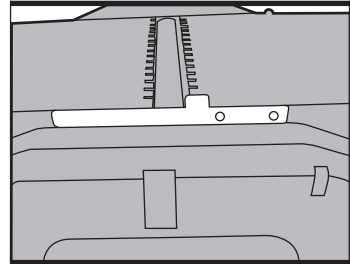


Fig 3

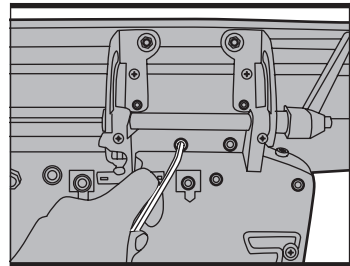
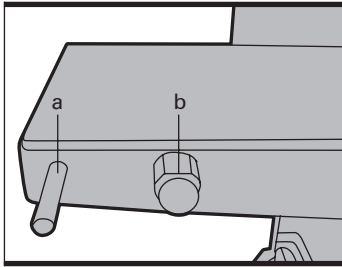


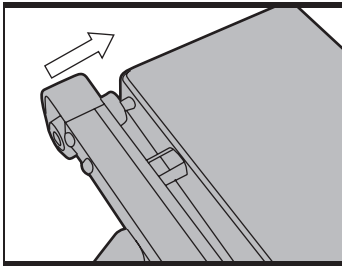
Fig 4

# 8" THICKNESS PLANER

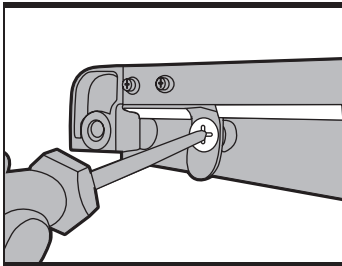




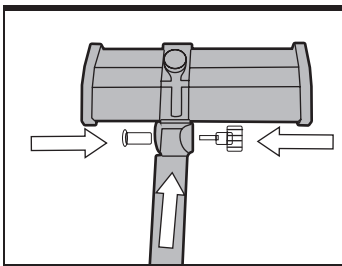
**Fig 5**



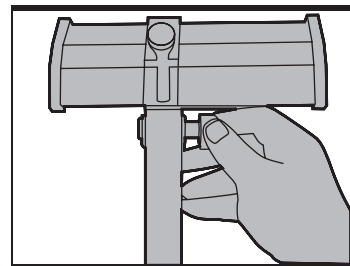
**Fig 6**



**Fig 7**



**Fig 8**



**Fig 9**

### **3. Fitting the blade (cutter) guard (9) (See Fig 5-9):**

1) Familiarise yourself with the blade guard locating pivot pin (a), and the blade guard limiting screw pole (b) situated on the side of the planer out-feed table (13).

2) Remove the limiting screw.

3) Slide the guard arm assembly (14) over the locating pivot pin.

4) Replace the limiting screw and tighten to secure.

5) Fitting the cutter guard to the guard assembly arm (14):

- Set out the parts as shown in Fig 9.
- Slide the arm into the guard.
- Ensure the holes on the guard and arm line up.
- Push the threaded spacer through the holes.
- Secure with the thumbscrew.





## OPERATION

**Important:** This planer-thicknesser is intended specifically for planing and thicknessing operations on solid timber. When being thicknessed, the contact surface of the work piece must be flat. If working with bigger or heavier work-pieces it is necessary to clamp the machine firmly to its supporting bench or table. The machine is not suitable for operation outdoors when raining or in any damp environment. Any other use beyond this scope is considered as failing to comply with the machines intended purpose. The manufacturer is not liable for any damage or injuries caused as a result of this; the risk is borne solely by the user.

The ON / OFF (NVR) switch (1) of machine is located on the left side below the yellow cover.

To switch the machine on: Lift the yellow cover and press the green button "1".

To switch the machine off: Press the red button "0" or firmly close the cover.

The switch can be locked to prevent the machine from being inadvertently switched on by folding down the yellow cover.

This machine is equipped with an overload switch (2) for motor running protection. Once the overload occurs, the machine will stop automatically. After a while, the overload switch can be reset.

**Warning:** Operation of any power tool can result in foreign objects being thrown into the eyes which can result in severe eye injury.

Always wear safety goggles, it is also advisable to wear ear protection particularly if using the planer for extended periods.

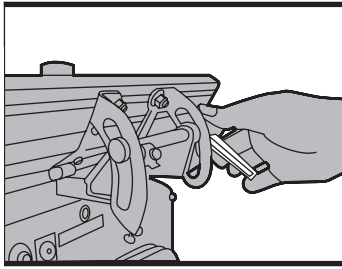
For your own safety, read all of the safety instructions in this manual and adhere to all precautions before and during operation of the planer thicknesser.

### Before each use:

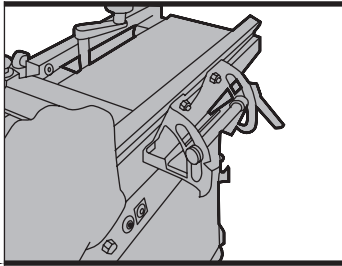
- Make sure all moving parts are free from interference.
- Make sure blades are aligned and correctly attached to cutter-head (See maintenance section of this manual).
- Do not plug in the planer thicknesser unless the

# 8" THICKNESS PLANER

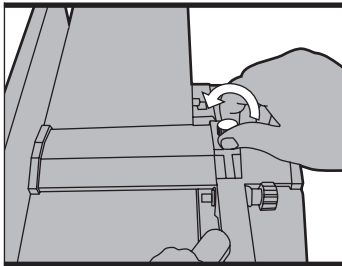




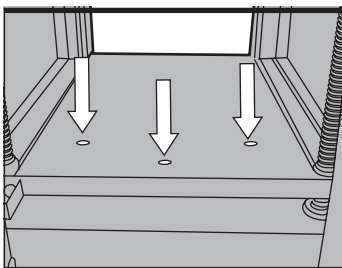
**Fig 10**



**Fig 11**



**Fig 12**



**Fig 13**

switch is in "off" position.

- After turning the switch on, allow the cutter block to come to full speed before commencing the operation.
- Keep hands clear of all moving parts.
- Do not force the cut. Slowing or stalling the cutter will force the overload to cut in and will greatly reduce the life of the motor.
- Use quality dry timber. Blades last longer and cuts are smoother with good quality wood.
- Do not pull the workpiece back over the cutter block towards the infeed table.
- Support the work-piece adequately at all times during operation; maintain control of the work-piece.
- Take precautions against kickback, do not permit anyone to stand or cross in the line of cutter-head's rotation. Kickback or thrown debris will travel in this direction.
- Replace or sharpen blades as they become damaged or dull.
- Whenever possible always use the push blocks supplied to feed work across the cutter head.

## **1. Planing mode:**

### **1.1 Setting the guide fence (8). (See Fig 10-11)**

- 1) Turn the fence angle locking handle (20) anti-clockwise to loosen.
- 2) Use the angle guide (19) and the angle pointer (17) to set the fence at the desired angle.
- 3) Re-tighten the locking handle (20) to secure the fence guide (8).

**Note:** There are positive stops at 45° and 90° this is to make it easier to set the fence at these 2 popular angles.

### **1.2 Fitting the extraction port. (See Fig 12-17)**

The dust extraction port (F) is also one of the safety devices of the planer thicknesser. Once fitted correctly, the extraction port covers the underside of the cutter-block and engages one of the safety interlock switches, which allows the machine to run safely.

- 1) Fit the height adjusting handle (11) over its shaft.
- 2) Turn the crank anti-clockwise, this will lower the thickening table.





3) Continue turning the handle until the thicknesser table reaches its lowest point.

4) On the bottom of the thicknesser table there are 3 holes, these are the locating holes for the corresponding locating points on the extraction port assembly.

5) Make note of "tab a" as this is the point that engages the interlock switch and allows the planer thicknesser to run safely.

6) Take care to ensure that this "tab" is located correctly whilst fitting the dust extraction port.

7) Hold the dust extraction port assembly at approximately 45° and slide it into place onto the thicknesser bed.

8) Ensure that the 3 locating points line up with the corresponding holes on the thicknesser bed and set the port flat against the bed.

9) Secure the extraction port by fitting and tightening the supplied nut onto the middle (threaded) locating point.

10) Turn the height adjusting handle (11) clockwise to raise the thicknesser bed. This will secure the extraction port in place as well as engaging the safety interlock switch.

**Caution:** Do not secure the extraction port too tightly. If too much force is applied to the height adjusting handle the extraction port will go beyond its optimum position, the safety interlock switch will disengage and the motor will not run.

11) Once fitted correctly, the extraction port should look as in Fig 16.

12) Finally, fit the extraction port adapter (E) by simply sliding it over the extraction port as in Fig 17.

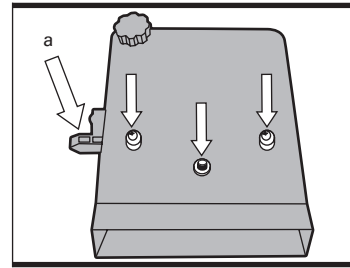


Fig 14

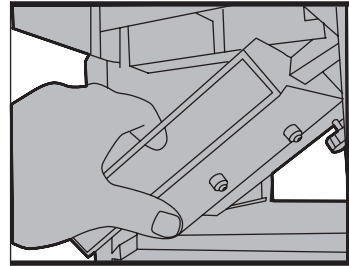


Fig 15

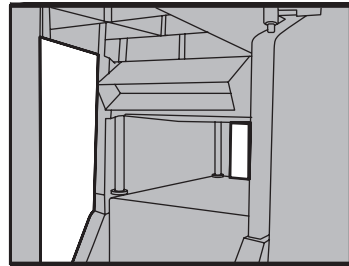


Fig 16

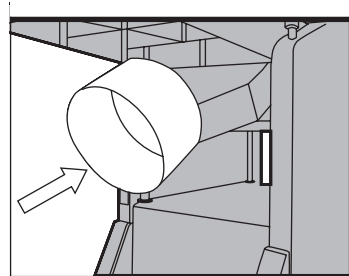
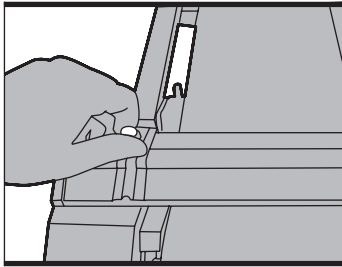


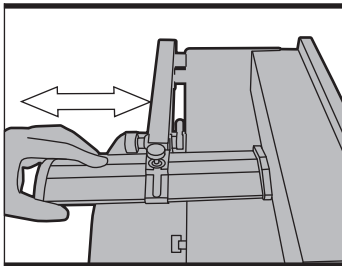
Fig 17

## 8" THICKNESS PLANER

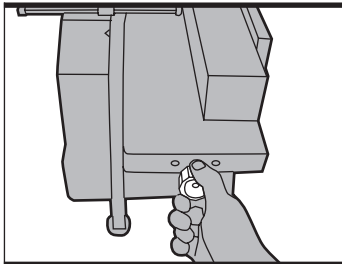




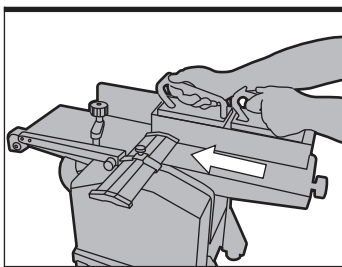
**Fig 18**



**Fig 19**



**Fig 20**



**Fig 21**

### 1.3 Setting the blade guard (9). (See Fig 18-19)

- 1) Loosen the blade guard locking knob (10).
- 2) Pull back the blade guard (9).
- 3) Set the workpiece against the guide fence (8).
- 4) Slide the blade guard (8) towards the workpiece (leaving a small gap of a few millimetres).
- 5) Re-tighten the blade guard locking knob (10) to secure.

**Caution:** When the machine is not in use the plug should be removed from the mains socket and the blade guard (9) should be set so that it covers the whole of the cutter assembly so as to reduce the risk of injury.

### 1.4 Setting the depth of cut. (See Fig 20)

The depth of cut is the amount of material removed from the workpiece with a single pass over the cutter-block. It is set by the in-feed table moving up / down in relation to the out-feed table (this is fixed).

**Note:** The maximum cut of 3mm should only be utilized on softer woods. The planer thicknesser will give a much better quality finish on harder woods such as oak if less material is removed on each pass.

- 1) Turn the cut depth control knob (5) clockwise to reduce the depth of cut and anti-clockwise to increase the depth of cut.
- 2) The scale to the left of the in-feed table shows the amount of material that will be removed per pass.
- 3) 1 relates to approximately 1mm, 2 relates to approximately 2mm etc.

### 1.5. Planing mode: Making a pass with the workpiece. (See Fig 21)

Once everything is set as needed the planer thicknesser can now be safely operated.

- 1) Ensure that the cutter block is free from foreign objects (including the workpiece to be planed).
- 2) Connect the planer thicknesser to the mains supply.
- 3) Turn the planer on with the green "1" button (1).
- 4) Allow the planer to reach its maximum speed.
- 5) Place the workpiece onto the in-feed table and ensure that the workpiece stays parallel with the in-feed table for the whole pass.
- 6) Slowly push the workpiece forward (over the







cutter-block).

Caution: It is much safer (particularly when using a thin / small workpiece) to use the supplied push blocks.

7) Repeat these steps until the correct amount of material has been removed.

**Note:** Keep firm and even pressure on the workpiece as it passes over the in-feed table and continue pushing forward until the back of the workpiece passes the cutter-block.

## 2. Thicknesser mode:

### 2.1 Setting the blade guard (9). (See Fig 22-23)

- 1) Loosen the blade guard locking knob (10) (turn clockwise).
- 2) Slide the blade guard (9) out as far as it will go.

### 2.2 Thicknesser mode: Fitting the extraction port. (See Fig 24-26)

There are 2 holes on the out-feed table of the planer, 1 x un-threaded hole (a) for locating the extraction port, and 1 x threaded hole (b) for securing the extraction port as shown in Fig 24. These holes work in conjunction with the fixings on the extraction port.

- 1) Insert the locating pin (a) on the extractor port into the locating pin hole (a) on the out-feed table.
- 2) Tighten the securing screw (b) on the extraction port into the securing pin hole (b) on the out-feed table.
- 3) Ensure tab (c) sits over the machines 2nd interlock safety switch. You will hear the switch click as the securing screw is tightened.
- 4) Slide the extraction port adapter (7) over the extractor port.

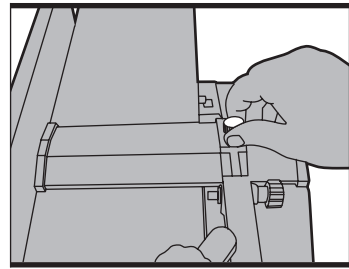


Fig 23

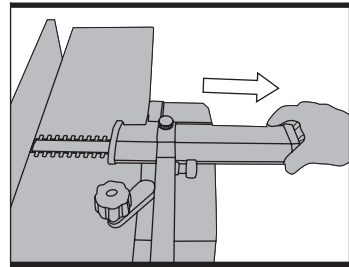


Fig 23

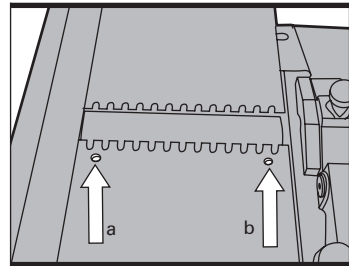


Fig 24

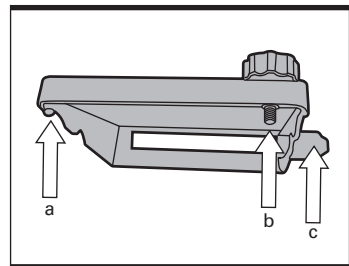
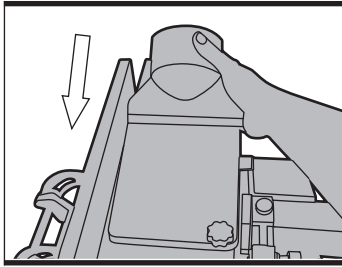


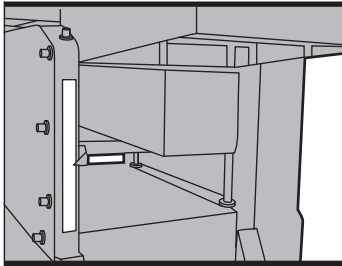
Fig 25

# 8" THICKNESS PLANER





**Fig 26**



**Fig 27**


### **2.3 Thicknesser mode: Setting the depth of cut. (See Fig 27)**

The depth of cut is set by how high / low the thickening bed is in relation to the cutter-block.

- 1) Measure the workpiece.
- 2) Set the bed to just over this measurement, using the scale to the left of the in-feed table.
- 3) Turn the height adjusting handle (11) anti-clockwise to lower the thickening bed, clockwise to raise it.
- 4) Ensure that the cutter block is free from foreign objects (including the workpiece to be thickened).
- 5) Connect the planer thicknesser to the mains supply.
- 6) Turn the thicknesser on with the green "1" button (1).
- 7) Allow the planer to reach its maximum speed.
- 8) Place the workpiece onto the in-feed table.
- 9) Turn the height adjustment handle (11) half a turn clockwise to raise the bed.
- 10) Continue this process until the workpiece comes into contact with the thicknesser drive rollers.
- 11) Once the workpiece comes into contact with the rollers they will automatically "pull" it through the machine and over the cutterblock.
- 12) Continue this process until the workpiece is at the desired thickness.

**Note:** A longer workpiece should be supported after it leaves the machine to ensure a good even finish.

## **MAINTENANCE**

 **Caution:** Always ensure that the machine is turned off and that the plug is removed from the mains supply before carrying out any repairs or maintenance.

### **1. Before each use.**

- Check for damaged parts and repair or replace them as necessary.
- Ensure all nuts and bolts etc are secure.
- Ensure that all moving parts move freely and are not binding prior to starting the machine.
- Remove adjusting keys and wrenches and check to see that keys and adjusting wrenches are





removed from the tool before turning it on.

## 2. During use.

- Constantly check for abnormalities. Stop the operation immediately if something does not look or sound right and have the machine checked by a suitably qualified person.
- Remove any buildup of chippings and pay particular attention around the base of the planer thicknesser, as build up there will prevent the cooling air from reaching the motor.

## 3. After each use.

- Remove the extraction port and clean out all chippings etc. Dry air would be good for this operation but a soft brush would also work. Caution: Always wear a dust mask and eye protection when using dry air.
- Remove all chippings etc from the planer thicknesser.
- Remove all chippings etc from around the air inlets of the motor. If these become blocked the motor will become too hot and its service life will be greatly reduce.
- Wrap the mains lead carefully around the cable clips (21). This will reduce the risk of tripping and / or damage to the cable.

## 4. After 10 hours running. (See Fig 28)

- Lubricate the bush bearings.
- Treat the threaded spindles for height adjustment of the thicknessing table with dry lubricant.

## 5. Periodically. (See Fig 29)

Over time resin or other contaminants may build up on the planer in-feed and out-feed tables, as well as the thicknesser table and the in-feed and out-feed rollers.

- To ensure easy steady feeding the beds and the rollers will need to be cleaned periodically.
- Periodically check that the anti-kickback fingers move freely (they should fall back under their own weight).
- Check that the points of the anti-kickback fingers are not rounded.

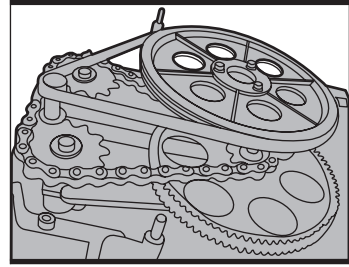


Fig 28

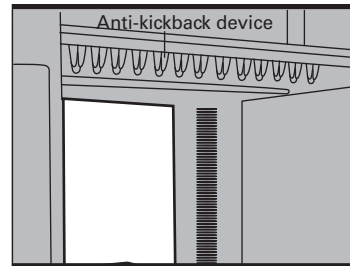
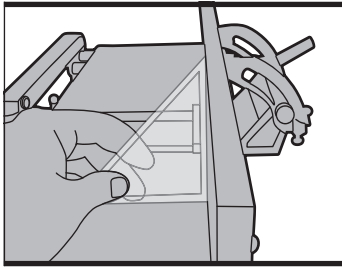


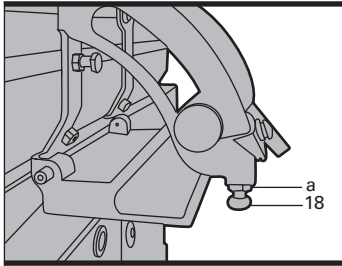
Fig 29

# 8" THICKNESS PLANER

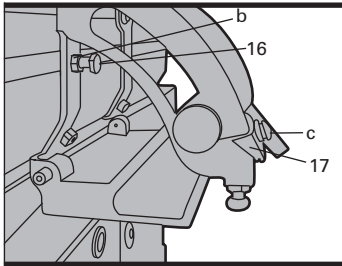




**Fig 30**



**Fig 31**



**Fig 32**

## 6. Setting the positive stops on the guide fence:(See Fig 30-32)

The positive stops at 90° and 45° are set at the factory to ensure accuracy, however over time they may need to be reset.

- Loosen the fence angle lock handle (20).
- Sit a 90° square firmly on the planer table.
- Set the guide fence against the square, this will give an angle of 90° between the bed and the fence.
- Loosen the lock nut (a).
- Tighten / loosen the angle locking bolt until it sits against the angle stop on the angle guide (19), whilst ensuring that the 90° angle is kept.
- Re-tighten the lock nut to hold the bolt securely in place.
- Loosen the angle pointer screw (c) and set the angle pointer so that it reads 90°.
- To set the 45° positive stop, set the guide fence so that the angle pointer is at 45° .
- Loosen the 45° lock nut (b).
- Tighten / loosen the angle locking bolt until it sits against the 45° stop on the angle guide.
- Re-tighten the locking nut to secure.





## 7. Replacing the cutter blades:

### 1) Removing the blades. (See Fig 33-35)

**Caution:** Not to touch the tips of the blades as it would cause hurts to you.

- Remove the guide fence (8).
- Loosen the blade guard locking screw (10) and slide the blade guard (9) away from the cutter-block as far as it will go.
- Turn the cutter-block so that one of the blades is exposed in the gap between the in-feed (6) and out-feed (13) tables.
- Turn the five blade tensioning screws (anti-clockwise) to loosen.
- Once all five screws have been loosened, the blade complete with the blade clamping device can be easily removed.

**Note:** Remember the correct orientation of the blade to ensure that the new one can be fitted correctly.

**Caution:** Take care not to lose the blade tensioning springs from the cutter-block after the blade assembly has been removed.

- Whilst removed, all parts (including the cutter-block) should be thoroughly cleaned.

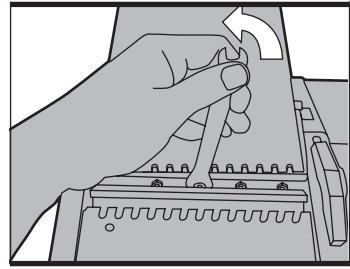


Fig 33

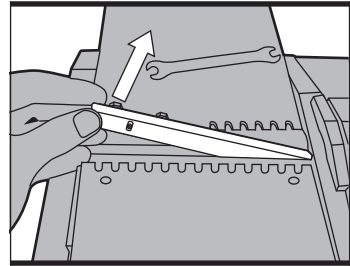


Fig 34

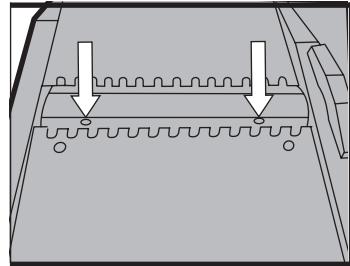
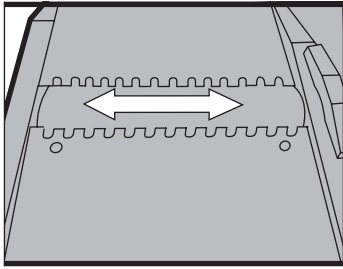


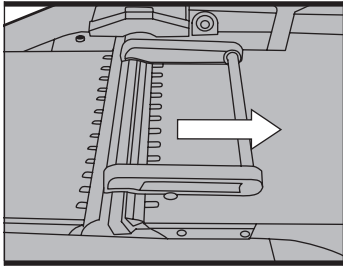
Fig 35

# 8" THICKNESS PLANER

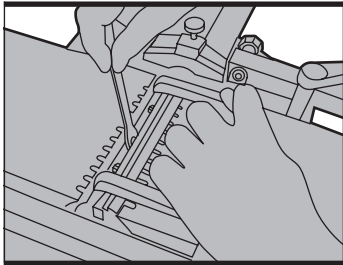




**Fig 36**



**Fig 37**



**Fig 38**

## **2) Fitting the blades: (See Fig 36-38)**

- Fit the blade correctly into the clamping device.
- Slide both components into the cutter-block, taking care that they are fitted in the correct direction etc.
- Centre the blade assembly laterally.
- Set the blade setting block (C) over the cutter-block.
- Pull the setting block back so that it sits firmly against the front edge of the planing out-feed table (13).
- Put firm downward pressure on the setting block whilst keeping it firmly against the edge of the out-feed table. This will push the blade into place.
- Keep firm pressure on the setting block and tighten the 5 blade tensioning screws.
- Once complete, turn the cutter-block to expose the 2nd blade and repeat the process to replace that blade.

**Note:** Once this operation is complete, ensure that the cutter-block turns freely by hand before re-connecting the machine to the mains supply. Replace all safety guards immediately after completing this operation.





## 8. Replacing the motor brushes: (See Fig 39-41)



**Caution:** This operation should only be carried out by a suitably qualified person.

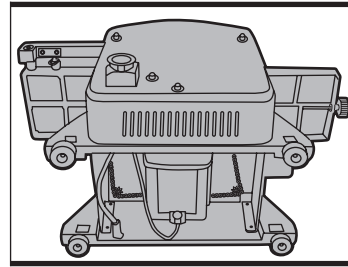
- Carefully turn the planer thicknesser onto its side.

- This will expose the motor of the machine.
- Take a slotted screwdriver (not supplied) and locate it in the slot on the motor brush cap.
- Turn the screwdriver anti-clockwise until the cap can be removed and take care when removing the cap as there is a spring under compression holding the brush in place.
- Remove the brush and check the length; If the brush needs changing fit the new brush and tighten the cap to retain it.

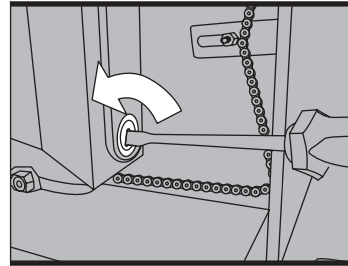
If the brush is not worn but is sticking inside the holder there may be carbon buildup that needs to be removed. The best way to remove the carbon is by blowing dry air into the holder, but a small stiff brush or pipe cleaner could be used to do the same job. The brush will also need cleaning as some of the buildup may be stuck to it.



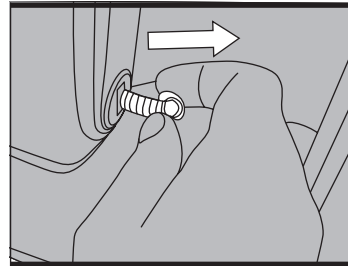
**Caution:** When removing or cleaning the brushes eye protection and a dust mask should be worn; particularly if using dry air. Clean or change the brushes in a well ventilated area and ensure everyone in that area also wear the appropriate protection.



**Fig 39**



**Fig 40**




**Fig 41**

# 8" THICKNESS PLANER





## TROUBLESHOOTING

 **Caution:** Troubleshooting could lead to an increased risk to the operator due to the fact that safety guards / covers may have to be removed. It is therefore particularly important that all the measures necessary for safe working are taken.

<b>Fault</b>	<b>Possible causes</b>	<b>Possible solutions</b>
Machine will not run	No mains voltage.	Check the supply.
	Fuse blown.	Check the fuse and replace if necessary.
	Overload switch has cut in.	Allow the machine to cool and reset the switch.
	Faulty NVR switch.	Check and replace if necessary.
	Carbon brushes worn.	Check and replace if necessary.
	Faulty motor.	Check and replace if necessary.
	Damaged mains lead.	Check and replace if necessary.
	Safety interlock switch is not correctly engaged	Check that the extraction port is correctly seated.
Speed drops whilst the machine is under load.	Cutting depth is too great.	Reduce the cutting depth.
	Feed rate is too fast.	Reduce the feed rate.
	Dull cutter blades.	Replace / sharpen the cutter blades.
The motor cuts out whilst under no load.	Mains failure.	Check the supply.
	Motor has exceeded its duty cycle.	Allow the motor to cool and reset the overload.
	Faulty motor.	Check and replace if necessary.
	Faulty NVR switch.	Check and replace if necessary.







The motor cuts out whilst under load.	Motor has exceeded its duty cycle and the overload has cut in.	Allow the motor to cool and reset the overload.
	Cutting depth is too great so the overload has cut in.	Allow the motor to cool and reset the overload. Reduce the cutting depth.
	Feed rate is too fast so the overload has cut in.	Allow the motor to cool and reset the overload. Reduce the feed rate.
	Dull cutter blades so the overload has cut in.	Replace or sharpen the blades, allow the motor to cool and reset the overload.
Poor finish on workpiece.	Dull or damaged blades.	Replace or sharpen the blades.
	Uneven feed rate.	Ensure constant pressure on the work piece whilst planing.
	Feed rate too fast.	Reduce the speed of feed.
Extraction port becomes blocked whilst thicknessing (without external extraction).	Cutting depth too great.	Reduce the cutting depth.
	Wood is too damp.	Allow the wood to dry.
Extraction port becomes blocked whilst planing (without external extraction)	Cutting depth too great.	Reduce the cutting depth.
	Feed rate too fast.	Reduce the feed rate.
	Wood is too damp.	Allow the wood to dry.

## 8" THICKNESS PLANER





## ENVIRONMENTAL PROTECTION



Waste electrical products should not be disposed of with household waste. Please recycle where facilities exist. For further information visit [www.recycle-more.co.uk](http://www.recycle-more.co.uk)

## PLUG REPLACEMENT

If you need to replace the fitted plug then follow the instructions below.

### Important

The wires in the mains lead are coloured in accordance with the following code:

**Green & yellow - Earth**

**Blue - Neutral**

**Brown - Live**

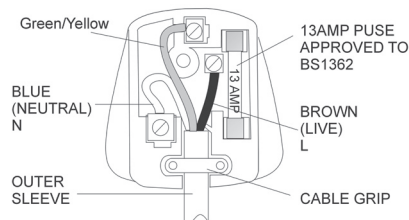
As the colours of the wires in the mains lead of this appliance may not correspond with the coloured markings identifying the terminals in your plug, proceed as follows. The wire which is coloured **green & yellow** must be connected to the terminal which is marked with **E** or  $\perp$ .

The wire which is coloured **blue** must be connected to the terminal which is marked with **N**. The wire, which is coloured brown, must be connected to the terminal, which is marked with the letter **L**.

**Warning:** Never connect live or neutral wires to the earth terminal of the plug. Only fit an approved 13 Amp BS1363/A plug and the correct rated fuse.

**Note:** If a moulded plug is fitted and has to be removed take great care in disposing of the plug and severed cable, it must be destroyed to prevent engaging into a socket.

If the supply cord is damaged it must be replaced by a service agent or a similarly qualified person in order to avoid hazard.





# Erbauer®

## Declaration of Conformity

We, Importer  
**Erbauer (UK) LTD BA22 8RT**

Declare that the product  
**8" THICKNESS PLANER**  
**ERB052BTE**

Complies with the essential health and safety requirements of the following directive:

**2004/108/EC.** –EMC Directive.

**73/23 EEC, 93/68 EEC.** –Low Voltage Directive.

**98/37 EC.** –Machinery Directive.

**2002/95/EC** Restrictions of the Use of Certain Hazardous Substances in Electrical and Electronic Equipment

Standards and technical specifications referred to:

**EN 61029-1: 2000/+A11: 2003+A12: 2003**

**prEN 61029-2-3:2004**

**EN 55014-1:2000/+A1: 2001+A2: 2002**

**EN 55014-2: 1997/+A1: 2001**

**EN 61000-3-2:2000+A2:2005**

**EN 61000-3-11: 2000**

### Authorised Signatory

Date: 01/01/07

Signature: *P. C. Harries*

Name: Peter Harries  
Erbauer (UK) Ltd  
Quality Manager

2007

## 8" THICKNESS PLANER





**Erbauer®**

