

## Original Instruction Manual

**RSBG6 6" Bench Grinder**

**RSBG8 8" Bench Grinder**

Version 3.0  
November 2012



To register this product please visit  
**[www.recordpower.info](http://www.recordpower.info)**

It is important to register your product as soon as possible in order to receive efficient after sales support and be entitled to the full **5 year guarantee**. Your statutory rights are not affected.  
Please see back cover for contact details.



Always wear safety glasses when using woodworking equipment.



Always read the instructions provided before using woodworking equipment.

### Important

For your safety read instructions carefully before assembling or using this product.

Save this manual for future reference.

# Contents

- 1.** Explanation of Symbols
  - 2.** General Health & Safety Guidance
  - 3.** Additional Health & Safety Guidance for Bench Grinders
  - 4.** Electrical Connection
  - 5.** Record Power Guarantee
  - 6.** Specifications
  - 7.** Installation
  - 8.** Operating the Grinder
  - 9.** Mounting of Wheels
  - 10.** Wheel Care
  - 11.** Maintenance
  - 12.** Dust Extraction
  - 13.** Control Identification
  - 14.** Parts List & Diagrams
- Certificate of Conformity

# 1. Explanation of Symbols

**THE SYMBOLS AND THEIR MEANINGS SHOWN BELOW MAY BE USED THROUGHOUT THIS MANUAL. PLEASE ENSURE THAT YOU TAKE THE APPROPRIATE ACTION WHEREVER THE WARNINGS ARE USED.**

## **Mandatory Instructions**



Read and fully understand the instruction manual before attempting to use the machine.



Indicates an instruction that requires particular attention



Wear protective eyewear



Use respiratory protective equipment



Use hearing protection



Use suitable protective footwear



Use protective work gloves

## **Warning**



Indicates a risk of severe personal injury or damage to the machine



Indicates a risk of severe personal injury from electrical shock



Risk of personal injury from lifting of heavy items



Indicates a risk of severe personal injury from airborne objects



Risk of fire

## 2. General Health & Safety Guidance

**ENSURE THAT YOU CAREFULLY READ AND FULLY UNDERSTAND THE INSTRUCTIONS IN THIS MANUAL BEFORE ASSEMBLY, INSTALLATION AND USE OF THIS PRODUCT. KEEP THESE INSTRUCTIONS IN A SAFE PLACE FOR FUTURE REFERENCE.**

**WARNING:** for your own safety, do not attempt to operate this machine until it is completely assembled and installed according to these instructions.

**WARNING:** When using any machine, basic safety precautions should always be followed to reduce the risk of fire, electric shock and personal injury.

### Safe Operation

#### 1. Use Personal Protective Equipment (PPE)

- The operation of any machine can result in foreign objects being thrown into your eyes, which can result in severe eye damage. Protective eyewear or other suitable eye protection or face shield should be used at all times. Everyday spectacles only have impact resistant lenses. They are not protective eyewear and do not give additional lateral protection.
- Use respiratory protective equipment (dust mask etc.) if the machining operation creates dust. Exposure to high levels of dust created by machining hardwoods, softwoods and man made composite boards can result in serious health problems. Some imported hardwoods give off highly irritating dust, which can cause a burning sensation. The use of respiratory protective equipment should not be seen as an alternative to controlling the risk of exposure at source by using adequate dust extraction equipment.
- The use of ear plugs or ear defenders is recommended when the machine is in use, particularly if the noise level exceeds 85 dB.
- Wear suitable protective gloves when handling cutting tools or blades. Gloves should NOT be worn when using the machine as they can be caught in moving parts of the machine.
- Non-slip safety footwear is recommended when using the machine and handling large work pieces.

#### 2. Dress appropriately

- Do not wear loose clothing, neckties or jewellery; they can be caught in moving parts of the machine.
- Roll up long sleeves above the elbow.
- Wear protective hair covering to contain long hair.

#### 3. Safety warnings

- Find and read any warning labels on the machine
- It is important that any labels bearing health and safety warnings are not removed, defaced or covered. Replacement labels can be obtained by contacting our Customer Service Department.

#### 4. Familiarise yourself with the machine

- If you are not thoroughly familiar with the operation of this machine, obtain advice from your supervisor, instructor, or other qualified person or contact your retailer for information on training courses. Do not use this machine until adequate training has been undertaken.

#### 5. Take care when moving or positioning the machine

- Some machines can be very heavy. Ensure the floor of the area in which the machine is to be used is capable of supporting the machine.
- The machine and its various components can be heavy. Always adopt a safe lifting technique and seek assistance when lifting heavy components. In some cases it may be necessary to use mechanical handling equipment to position the machine within the work area.
- Some machines have optional wheel kits available to allow them to be manoeuvred around the workshop as required. Care should be taken to install these according to the instructions provided.
- Due to the nature of the design of some machines the centre of gravity will be high making them unstable when moved. Extreme care should be taken when moving any machine.

#### 6. The machine should be level and stable at all times

- When using a leg stand or cabinet base that is designed to be fitted to the machine, always ensure that it is securely fastened to the machine using the fixings provided.
- If the machine is suitable to be used on a workbench, ensure that the workbench is well constructed and capable of withstanding the weight of the machine. The machine should always be securely fastened to the workbench with appropriate fixings.
- Where possible, floor standing machines should always be secured to the floor with fixings appropriate to the structure of the floor.
- The floor surface should be sound and level. All of the feet of the machine should make contact with the floor surface. If they do not, either re-locate the machine to a more suitable position or use packing shims between the feet and the floor surface to ensure the machine is stable.

#### 7. Remove adjusting keys and wrenches

- Ensure that all adjusting wrenches and keys are removed before switching the machine 'ON'. There is a risk of severe personal injury or damage to the machine from airborne objects.

#### 8. Before switching the machine 'ON'

- Clear the machine table of all objects (tools, scrap pieces etc.)
- Make sure there is no debris between the work piece and the table / work support.
- Ensure that the work piece is not pressed against, or touching the saw blade or cutting tool.
- Check all clamps, work holding devices and fences to ensure that they are secure and cannot move during machining operations.
- Plan the way that you will hold and feed the work piece for the entire machining operation.

#### 9. Whilst machining

- Before starting work, watch the machine while it runs. If it makes an unfamiliar noise or vibrates excessively, switch the machine 'OFF' immediately and disconnect it from the power supply. Do not restart until finding and correcting the source of the problem.

## 2. General Health & Safety Guidance - Cont.

### 10. Keep the work area clear

- Working clearances can be thought of as the distances between machines and obstacles that allow safe operation of every machine without limitation. Consider existing and anticipated machine needs, size of material to be processed through each machine and space for auxiliary stands and/or work tables. Also consider the relative position of each machine to one another for efficient material handling. Be sure to allow yourself sufficient room to safely operate your machines in any foreseeable operation.
- Cluttered work areas and benches create the risk of accidents. Keep benches clear and tidy away tools that are not in use.
- Ensure that the floor area is kept clean and clear of any dust and debris that may create trip or slip hazards.

### 11. Consider the work area environment

- Do not expose the machine to rain or damp conditions.
- Keep the work area well lit and ensure that there is artificial lighting available when there is insufficient natural light to effectively light the work area. Lighting should be bright enough to eliminate shadow and prevent eye strain.
- Do not use the machine in explosive environments eg. in the presence of flammable liquids, gases or dust.
- The presence of high levels of dust created by machining wood can present a risk of fire or explosion. Always use dust extraction equipment to minimise the risk.

### 12. Keep other persons away (and pets)

- The machine is designed to be used by one person only.
- Do not let persons, especially children, touch the machine or extension cable (if used) and keep visitors away from the work area.
- Never leave the machine running unattended. Turn the power supply off and do not leave the machine unattended until it comes to a complete stop.
- If the work area is to be left unattended, all machinery should be switched 'OFF' and isolated from the mains power supply.

### 13. Store machines safely when not in use

- When not in use, machines should be stored in a dry place, out of reach of children. Do not allow persons unfamiliar with these instructions or with the machine to operate it.

### 14. Do not overreach

- Choose a working position that allows your body to remain balanced and feed the work piece in to the machine without overreaching.
- Keep proper footing and balance at all times.

### 15. Electrical supply

- Electrical circuits should be dedicated to each machine or large enough to handle combined motor amp loads. Power outlets should be located near each machine so that power or extension cables are not obstructing high-traffic areas. Observe local electrical guidelines for proper installation of new lighting, power outlets, or circuits.

- The machine must be connected to an earthed power supply.
- The power supply must be equipped with a circuit breaker that provides short circuit, overload and earth leakage protection.
- The voltage of the machine must correspond to the voltage of the mains power supply.
- The mains plug fitted to the machine should always match the power outlet. Do not modify the plug in any way. If a replacement plug is required it should be fitted by a competent person and of the correct type and rating for the machine.
- If you are unsure about any electrical connections always consult a qualified electrician.

### 16. Avoid unintentional starting of the machine

- Most machines are fitted with a no-volt release (NVR) switch to prevent unintentional starting. If in doubt always ensure the machine switch is in the 'OFF' position before connecting it to the power supply. This means the machine will not automatically start up after a power cut or switching on of the power supply, unless you first reset the start switch.

### 17. Outdoor use

- Your machine should not be used outdoors.

### 18. Extension cables

- Whenever possible, the use of extension cables is not recommended. If the use of an extension cable is unavoidable, then it should have a minimum core cross section of 2.5mm<sup>2</sup> and limited to a maximum length of 3 metres.
- Extension cables should be routed away from the direct working area to prevent a trip hazard.

### 19. Guard against electric shock

- Avoid body contact with earthed or grounded surfaces such as pipes and radiators. There is an increased risk of electric shock if your body is earthed or grounded.

### 20. Always work within the machine's intended capacities

- Operator safety and machine performance are seriously adversely affected if attempts to make the machine perform beyond its limits are made.

### 21. Do not abuse the power cable

- Never pull the power cable to disconnect it from the power socket. Always use the plug.
- Keep the power cable away from heat, oil and sharp edges.
- Do not use the power cable for carrying or moving the machine.

### 22. Secure the work piece

- Ensure that the work piece is securely held before starting to machine it.
- When working within 300mm of the machining area, always use a push stick to feed the work piece in to the blade or cutting tool. The push stick should have a minimum length of 400mm. If the push stick becomes damaged, replace it immediately.
- Use extra supports (roller support stands etc.) for any work pieces large enough to tip when not held down to the table top.

## 2. General Health & Safety Guidance - Cont.

- Do not use another person as a substitute for a table extension, or as additional support for a work piece that is longer or wider than the basic table, or to help feed, support, or pull the work piece.
  - Do not attempt to machine more than one work piece at a time.
  - When feeding the work piece towards the blade or cutting tool never position your hands in direct line of the cutting path. Avoid awkward operations and hand positions where a sudden slip could cause your hand or fingers to move into the machining area.
- 23. Stay alert**
- Safety is a combination of operator common sense and alertness at all times when the machine is being used.
  - Use all machines with extreme care and do not use the machine when you are tired or under the influence of drugs, alcohol or medication.
- 24. Use the correct tool for the job**
- Do not use the machine for any purpose other than which it was designed.
  - When selecting replacement cutting tools and blades, always ensure that they are designed to cut the material that you intend to use them for. If in any doubt seek further advice from the manufacturer.
- 25. Connect dust extraction equipment**
- Always use dust extraction equipment. The dust extractor should be of suitable size and capacity for the machine that it is connected to and have a filtration level appropriate to the type of waste being collected. Refer to the relevant section of the manual for details of the specific dust extraction requirements for this machine.
  - The dust extractor should be switched 'ON' before starting the machine that it is connected to. The dust extractor should be left running for 30 seconds after the last machining operation is complete in order to clear any residual waste from the machine.
- 26. Ensure that the machine is correctly guarded**
- Never use the machine if any of the standard safety guards and equipment are removed or damaged.
  - Some machines incorporate safety interlocks to prevent the machine from being used without the guards in place. Never attempt to bypass or modify the interlocks to allow the machine to be used without the guards in place.
- 27. Maintain your machine with care**
- This manual gives clear instructions on installation, set up and operation of the machine and also details any routine and preventative maintenance that should be performed periodically by the user.
  - Remember always to switch off and unplug the machine from the power supply before carrying out any setting up or maintenance operations.
  - Follow any instructions for the maintenance of accessories and consumables.
  - Do not use compressed air to clean the machine. Always use a brush to dislodge dust in places that are awkward to reach and a dust extractor to collect the waste.
  - Inspect electric cables periodically and, if damaged, have them replaced by an authorised service facility or qualified electrician.
  - Inspect extension cables (if used) periodically and replace if damaged.
  - It is normal for electric motors to become hot during use. Take extreme care when working near the motor area. Allow the motor to cool down before carrying out any maintenance.
- 28. Keep cutting tools sharp and clean**
- Correctly maintained cutting tools are easier to control and less likely to bind.
  - Cutting tools and blades can become hot during use. Take extreme care when handling them and always allow them to cool before changing, adjusting or sharpening them.
- 29. Disconnect the machine from the power supply**
- When not in use, before servicing, changing blades etc. always disconnect the machine from the power supply.
- 30. Check for damaged parts**
- Before each use of the machine, it should be carefully checked to determine that it will operate properly and perform its intended function.
  - Check for alignment of moving parts, binding of moving parts, breakage of parts and any other conditions that may affect the operation of the machine.
  - A guard or other part that is damaged should be properly repaired or replaced by a qualified person unless otherwise indicated in this instruction manual.
  - Do not use the machine if the switch does not turn the machine 'ON' and 'OFF'.
  - Have defective switches replaced by a qualified person.
- 31. Warning!**
- The use of any accessory or attachment, other than those recommended in this instruction manual, or recommended by our Company may present a risk of personal injury or damage to the machine and invalidation of the warranty.
- 32. Have your machine repaired by a qualified person**
- This machine complies with the relevant safety rules and standards appropriate to its type when used in accordance with these instructions and with all of the standard safety guards and equipment in place. Only qualified persons using original spare parts should carry out repairs. Failure to do this may result in considerable danger to the user and invalidation of warranty.



## 3. Additional Health & Safety Guidance for Bench Grinders

### Safe Operation

- The bench grinder should be level and stable at all times
- Never attempt to lift the grinder while the wheels are in motion – the centrifugal force created by the rotating stones can cause the machine to be unstable and could cause serious personal injury.

### 2. Familiarise yourself with the machine

- Machining operations using bench grinders or grinding wheels have a history of serious accidents. Most serious accidents are caused by breakage of the grinding wheel due to damage, poor maintenance or incorrect mounting of the stone. Other accidents involve contact with the grinding wheel whilst running and sparks or waste material being thrown from the grinder.
- The risk of breakage is inherent in every abrasive wheel. Always handle grinding wheels with extreme care. They are brittle and the slightest impact can cause fractures within the stone.
- This machine is designed for the grinding and sharpening of tools and general purpose grinding of objects made from metal or alloy. Do not attempt to grind items made from any other material.

### 3. Before switching the machine 'ON'

- Check that the tool rests and spark guards are correctly adjusted for the grinding application being undertaken and that the fixings are secure. The spark guards and tool rests need to be close to the grinding wheel and will need regular adjustment as the wheel wears. The gap between the tool rest and grinding wheel should never be more than 1.5 mm.
- Visually check the grinding wheel for signs of damage or excessive wear. Check that the outer diameter of the wheel is greater than the minimum recommended diameters detailed in the manual. Replace any defective grinding wheels immediately.
- When fitting a new grinding wheel, it should first be inspected to ensure that it is not cracked or damaged. The new wheel should first be unpacked and cleaned with a brush and inspected for any obvious signs of damage. It should then be suspended from the central hole on a suitable dowel and gently tapped with a light, non-metallic object. If the wheel sounds dull, it may be cracked and should not be used. This test cannot be performed with the wheel already mounted on the machine.
- When fitting the grinding wheel to the machine, always ensure the clamping flanges are clean and free of any foreign bodies.
- When fitting any grinding wheel, ensure that there is a cardboard washer (known as a blotter) between each of the clamping flanges and the surface of the wheel. Never mount a wheel without the cardboard washers being in place. Replacement washers can be obtained by contacting our customer service department.
- Before fitting a replacement wheel, always check that it is the correct diameter and thickness to suit the machine and that the maximum speed rating on the wheel is higher than the maximum speed of the machine as detailed in the manual. Never attempt to modify a wheel to make it fit your machine.
- The bench grinder is only designed to accept grinding wheels of

the correct size to fit inside the wheel housing of the machine. Do not fit other accessories such as polishing mops, wire wheels etc. that will not fit inside the wheel housing. Never use the machine without the wheel housing in place.

- Take care not to over tighten the locking nut to secure the grinding wheel. Over tightening the nut will cause uneven stress on the centre of the wheel and may cause it to crack.
- Never attempt to mount a grinding wheel without the original clamping flanges in place, or if the flanges are damaged.

### 4. Whilst grinding

- Never stand directly in line with the grinding wheels when first starting the machine. Stand with your head and body to one side of the machine.
- Never grind on a new or cold wheel. Always let the machine run up to speed and run for a minute before applying work to it. If the machine vibrates excessively, switch the machine 'OFF' immediately. Do not use the machine until the cause of the vibration has been identified and rectified.
- Do not grind on the side of the wheel.
- Be aware that hot sparks can be a source of ignition. Never carry out grinding operations near flammable material or in an explosive environment (gas, liquid, vapors, dust etc).
- The work piece will become extremely hot after a very short period of contact with the grinding wheel. The work piece should be quenched regularly to prevent over heating. Do not touch the machined face of the work piece until you are sure that it has cooled sufficiently.
- Never apply coolant of any kind directly to the grinding wheel as it may adversely affect the bonding of the stone.
- The dust from abrasive wheels can be an irritant and a hazard to your health. Always use the machine in a well ventilated area and use additional respiratory protective equipment. Clean the machine regularly with a vacuum cleaner to remove waste material.
- Ensure that the work piece is applied to the tool rest before it is fed in to the grinding wheel. Unsupported work can catch on the grinding wheel and may be thrown from your hands.
- When grinding small work pieces, the use of jigs or fixtures to hold the work piece is recommended. Never try to machine an item that is too small to hold safely by hand.
- When switching the machine 'OFF' allow the stone to slow down naturally. Do not apply pressure to the stone in order to slow the machine down more quickly. Do not leave the machine until it has completely stopped.

### 5. Maintenance:

- The wheel will become glazed and the grinding face will need to be dressed to maintain efficient performance. Do not dress the side of the wheel.
- Regular truing or dressing of the grinding wheels will help reduce vibration of the machine, improve grinding efficiency and reduce

## 3. Additional Health & Safety Guidance for Bench Grinders - Cont.

the risk of injury caused by trapping of the work piece due to the wheel not being concentric.

- If using a dresser of the revolving cutter type, use the lugs provided on the dresser as an anchor against the tool rest of the machine to maintain even pressure to the grinding wheel.
- Ensure that the dressing tool does not become trapped between the tool rest and the grinding wheel.

6. This machine falls under the scope of the 'Health & Safety at Work etc. Act 1974', and the 'Provision & Use of Work Equipment Regulations 1998'. We recommend that you study and follow these regulations.

Further guidance can be found in the 'Safety in the use of abrasive wheels – publication HSG17' published by Health & Safety Executive and available from their website [www.hse.gov.uk](http://www.hse.gov.uk).



## 4. Electrical Connection

Machines supplied for use in the UK are fitted with a 3 pin plug conforming to BS1363, fitted with a fuse conforming to BS1362 and appropriate to the current rating of the machine.

Machines supplied for use in other countries within the European Union are fitted with a 2 pin Schuko plug conforming to CEE 7/7.

Machines supplied for use in Australia & New Zealand are fitted with a 3 pin plug conforming to AS/NZS3112.

In all cases, if the original plug or connector has to be replaced for any reason, the wires within the mains power cable are colour coded as follows:

### 230 V (Single Phase)

Brown: Live (L)  
Blue: Neutral (N)  
Green and Yellow: Earth (E)

The wire coloured brown must always be connected to the terminal marked 'L' or coloured red.

The wire coloured blue must always be connected to the terminal marked 'N' or coloured black.

The wire coloured green and yellow must always be connected to the terminal marked 'E' or with the earth symbol or coloured green / green and yellow.



**Earth Symbol**



**Double Insulated Symbol**

It is important that the machine is effectively earthed. Some machines will be clearly marked with the double insulated logo. In this case there will not be an earth wire within the circuit.

In the case of the BS1363 plug for use in the UK, always ensure that it is fitted with a fuse conforming to BS1362 appropriate to the rating of the machine. If replacing the original fuse, always fit a fuse of equivalent rating to the original. Never fit a fuse of a higher rating than the original. Never modify the fuse or fuse holder to accept fuses of a different type or size.

Where the current rating of the machine exceeds 13 A at 230 V, or if the machine is designated for use on a 400 V 3 phase supply a connector conforming to BS4343 (CEE17 / IEC60309) will be used. 230 V machines will be fitted with a blue 3 pin connector. The wiring for this type of this connector will be the same as shown above. 400 V, 3 phase machines will be fitted with a red 4 or 5 pin connector. The wiring for this type of connector is as shown below:

### 400 V (3 phase)

Brown: Live (L1)  
Black: Live (L2)  
Grey: Live (L3)  
Blue: Neutral (N)  
Green and Yellow: Earth (E)

The wire coloured brown must always be connected to the terminal marked 'L1'.

The wire coloured black must always be fitted to the terminal marked 'L2'.

The wire coloured grey must always be connected to the terminal marked 'L3'.

The wire coloured blue must always be connected to the terminal marked 'N' or coloured black.

The wire coloured green and yellow must always be connected to the terminal marked 'E' or with the earth symbol.

If in doubt about the connection of the electrical supply, always consult a qualified electrician.

### RSBG6 & RSBG8 Wiring Diagram

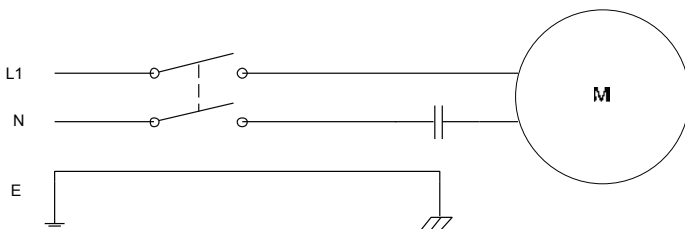

L1 = Live (Brown)  
N = Neutral (Blue)  
E = Earth (Yellow / Green)

## 5. Record Power Guarantee

“**Products**” means the Products sold by Record Power subject to these terms and conditions;

“**Record Power**” is Record Power Limited, whose company registration number is 4804158 and registered office address is Unit B, Ireland Industrial Estate, Adelphi Way, Staveley, Chesterfield, S43 3LS and sells through a network of Authorised Dealers;

“**Authorised Distributor**” is the nominated importer for your region who will generally sell through a network of Authorised Dealers. Details of Authorised Distributors for specific countries can be found in the Product manual or at [www.recordpower.info](http://www.recordpower.info);

“**Authorised Dealer**” is a retailer or business authorised to sell Record Power Products to end users.

### 1 Guarantee

- 1.1 Record Power guarantees that for a period of 5 years from the date of purchase the components of qualifying Products (see clauses 1.2.1 to 1.2.9) will be free from defects caused by faulty construction or manufacture.
- 1.2 During this period Record Power, its Authorised Distributor or Authorised Dealer will repair or replace free of charge any parts which are proved to be faulty in accordance with paragraphs 1.1 above provided that:
  - 1.2.1 you follow the claims procedure set out in clause 2 below;
  - 1.2.2 Record Power, our Authorised Distributor or Authorised Dealer are given a reasonable opportunity after receiving notice of the claim to examine the Product;
  - 1.2.3 if asked to do so by Record Power, its Authorised Distributor or Authorised Dealer, you return the Product, at your own cost, to Record Power's premises or other approved premises such as those of the Authorised Distributor or supplying Authorised Dealer, for the examination to take place;
  - 1.2.4 the fault in question is not caused by industrial use, accidental damage, fair wear and tear, wilful damage, neglect, incorrect electrical connection, abnormal working conditions, failure to follow our instructions, misuse, or alteration or repair of the Product without our approval;
  - 1.2.5 the Product has been used in a domestic environment only;
  - 1.2.6 the fault does not relate to consumable Products such as blades, bearings, drive belts or other wearing parts which can reasonably be expected to wear at different rates depending on usage (for full details contact Record Power or your local Authorised Distributor);
  - 1.2.7 the Product has not been used for hire purposes, by you or by a previous owner;
  - 1.2.8 the Product has been purchased by you as the guarantee is not transferable from a private sale.
  - 1.2.9 where the Product has been purchased from a retailer, the 5 year guarantee is transferable and begins on the date of the first purchase of the Product and in the event of a claim under this guarantee proof of the original purchase date will be required to validate the warranty period.

### 2 Claims Procedure

- 2.1 In the first instance please contact the Authorised Dealer who supplied the Product to you. In our experience many initial problems with machines that are thought to be due to faulty parts are actually solved by correct setting up or adjustment of the machines. A good Authorised Dealer should be able to resolve the majority of these issues much more quickly than processing a claim under the guarantee.
- 2.2 Any damage to the Product resulting in a potential claim under the guarantee must be reported to the Authorised Dealer from which it was purchased within 48 hours of receipt.
- 2.3 If the Authorised Dealer who supplied the Product to you has been unable to satisfy your query, any claim made under this Guarantee should be made directly to Record Power or its Authorised Distributor (for details of the Authorised Distributor in your country please see your Product manual or check [www.recordpower.info](http://www.recordpower.info) for details). The claim itself should be made in a letter setting out the date and place of purchase, and giving a brief explanation of the problem which has led to the claim. This letter should then be sent with proof of the purchase date (preferably a receipt) to Record Power or its Authorised Distributor. If you include a phone number or email address this will help to speed up your claim.
- 2.4 Please note that it is essential that the letter of claim reaches Record Power or its Authorised Distributor on the last day of this Guarantee at the latest. Late claims will not be considered.

### 3 Limitation of Liability

- 3.1 We only supply Products for domestic and private use. You agree not to use the Product for any commercial, business or re-sale purposes and we have no liability to you for any loss of profit, loss of business, business interruption or loss of business opportunity.
- 3.2 This Guarantee does not confer any rights other than those expressly set out above and does not cover any claims for consequential loss or damage. This Guarantee is offered as an extra benefit and does not affect your statutory rights as a consumer.

### 4 Notice

This Guarantee applies to all Products purchased from an Authorised Dealer of Record Power within the United Kingdom of Great Britain and Northern Ireland. Terms of Guarantee may vary in other countries – please check with the Authorised Distributor in your country (details of the Authorised Distributor for your country can be found in the manual or at [www.recordpower.info](http://www.recordpower.info)).

## 6. Specifications

	<b>RSBG6</b>	<b>RSBG8</b>
<b>Motor:</b>	240 V - 50 Hz	240 V - 50 Hz
<b>Motor Power:</b>	370 W	500 W
<b>Full load current:</b>	1.5 A	2.1 A
<b>Speed:</b>	2800 rpm 23 M/second	2800 rpm 30 M/second
<b>Wheel Dimensions:</b>		
<b>Grey:</b>	150 x 20 x 12.7 mm	200 x 25 x 16 mm
<b>White:</b>	150 x 40 x 12.7 mm	200 x 40 x 16 mm
<b>Noise Emissions (no load):</b>	Sound power level < 85 Db (A) Sound pressure level < 85 Db (A)	Sound power level < 85 Db (A) Sound pressure level < 85 Db (A)
<b>Weight:</b>	9.5 kg	14 kg

## 7. Installation

 The voltage supply to which the machine is to be connected must be within the range shown on the machine's specification label. The fuse rating must be 13A.

Any re-wiring should only be carried out by a qualified electrician.

Remember to check that the stone is running down towards the toolrest before using the machine.

Secure the machine firmly to a work bench or pedestal. The pedestal used must be fixed on a firm level surface.

## 8. Operating the Grinder

### **BEFORE STARTING THE MOTOR CHECK THAT:**

- End shields are secured to the main wheel guard by screws, which must be secured at all times.
- Wheel can be revolved freely by hand.
- The tool rests are in position, and adjusted to within 1.5 mm of the periphery face of the wheel and firmly secured.
- The protective spark shields fitted to the bench grinder are clean and secured in the correct position and that recommended and approved types of protective goggles, with clean lenses, are worn before operating the machine.
- All adjustments and checks must be made with the machine disconnected from the power supply.



### **WHEN STARTING AND USING THE MACHINE:**



- Check that the wheel, especially a new replacement wheel, is in sound condition by allowing the machine to run up to maximum speed and remain there for at least 30 seconds. During this check make sure that all personnel are standing clear of the machine.
- Allow the machine to run up to full speed before applying the workpiece to be ground.
- Feed the workpiece smoothly on to the grinding wheel and avoid harsh intermittent pressure and bumping on to the wheel.
- Always apply light but firm pressure and allow the wheel to rotate at the maximum possible speed.
- Avoid excessive pressure as this will tend to decrease the wheel speed and the amount of stock removal, causing uneven wear on the grinding wheel and overloading on the motor.
- Do not grind on the side face of the wheel.
- Do not stop the wheel by applying pressure to the side face of the wheel.
- Do not stop the wheel by applying pressure to it at the conclusion of the grinding operation. Always allow the machine to run down freely to rest.
- The machine should not be operated for more than 30 minutes per hour.

## 9. Mounting of Wheels

- Check the wheel dimensions: the outer diameter must not exceed recommended measurement and the hole must be correct as specified on the machines specification plate. The wheel should easily slide on to the spindle shaft and must never be forced on with pressure.
- Before mounting a wheel, it must be checked for flaws and damage. See section 3 of Additional Health & Safety Guidance for Bench Grinders.



- The wheel must be supplied with washers of paper or compressible material (blotters) placed around the hole on each side of the wheel. If these are missing or damaged, new ones must be put on.
- The inner and outer flanges, which are delivered with the machines, must always be used. They have and must retain the same diameter and must be kept clean and undamaged. The inner flange is secured to the spindle shaft.



- Place the wheel between the two flanges and fasten the nut. Note, there are left and right hand threads in the left and right sides, respectively. The nuts must be tightened enough to hold the wheel securely but avoid over tightening as this can cause damage to the wheel.

## 10. Wheel Care

Store spare grinding wheels flat on a firm surface with a layer of compressible material between the wheels and the storage surface. Similar material should be placed between them when a number are being stored.

As the grinding wheel is used it will wear. It is recommended that the wheel is replaced when the diameter has been reduced approximately 25% below its original size (e.g 300 mm to 225 mm, 200 mm to 150 mm, 150 mm to 112 mm and 125 to 94mm).

Wear on the wheel can cause eccentricity leading to machine vibration and intermittent contact with the work piece.

Unless this condition is corrected it can result in further damage to the wheel and possible harm to the motor bearings.

## 11. Maintenance

Replacement grinding wheels are available from Record Power and should be fitted following the instructions in section 9. Only genuine Record Power grinding wheels should be used to ensure the correct bore and diameter. Use of non Record Power wheels will invalidate the warranty.

To keep the grinding wheels in good condition it is recommended to periodically dress and clean the wheels. The **SDS1** Bench Grinder Dressing Stick is a coarse grey stick which will de-glaze the stone and open up the pores. The **SDS2** Bench Grinder Cleaning Stick should then be used to remove debris from the stone.

Refreshing the stone's surface as above will improve results and prolong the life of the grinding wheels.

## 12. Dust Extraction

Due to the small amounts of waste created when grinding, no dust extraction is necessary. Any debris which accumulates on the machine can be removed, once it has cooled, with a domestic vacuum cleaner, wet and dry vacuum or HPLV dust extractor using suitable fitments.

## 13. Control Identification

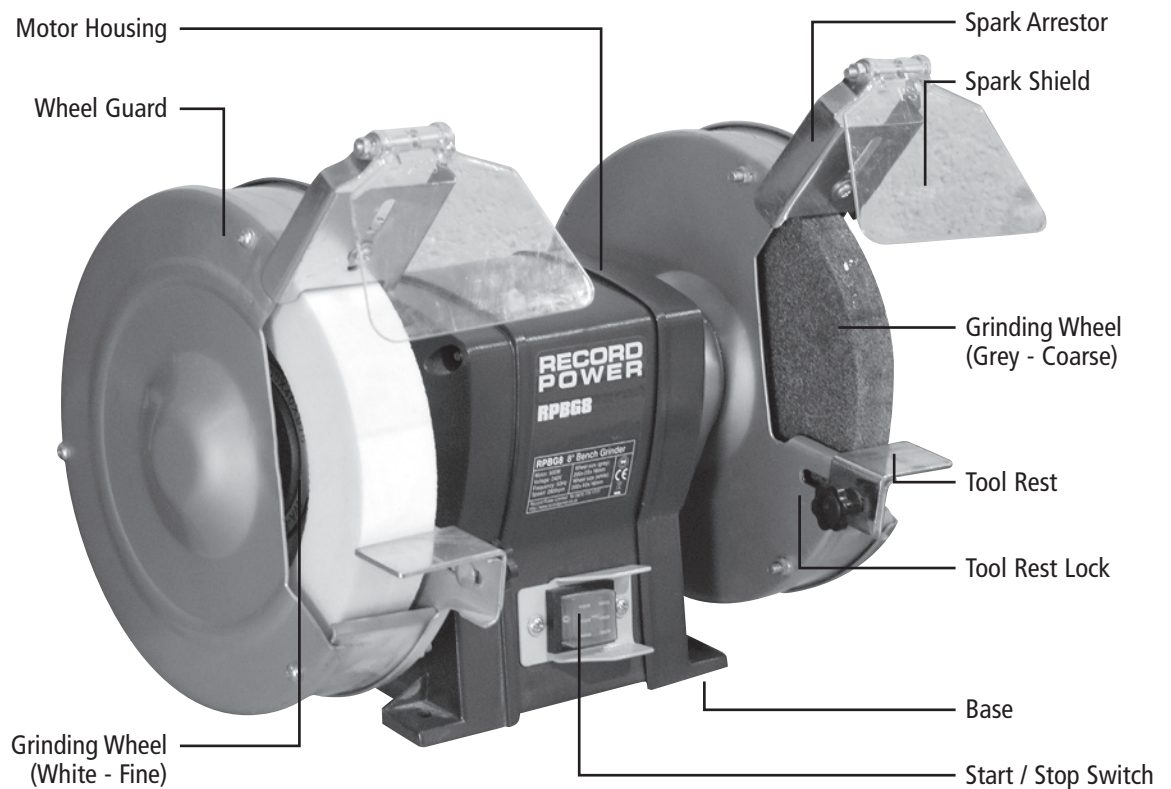

# 14. Parts Lists & Diagrams

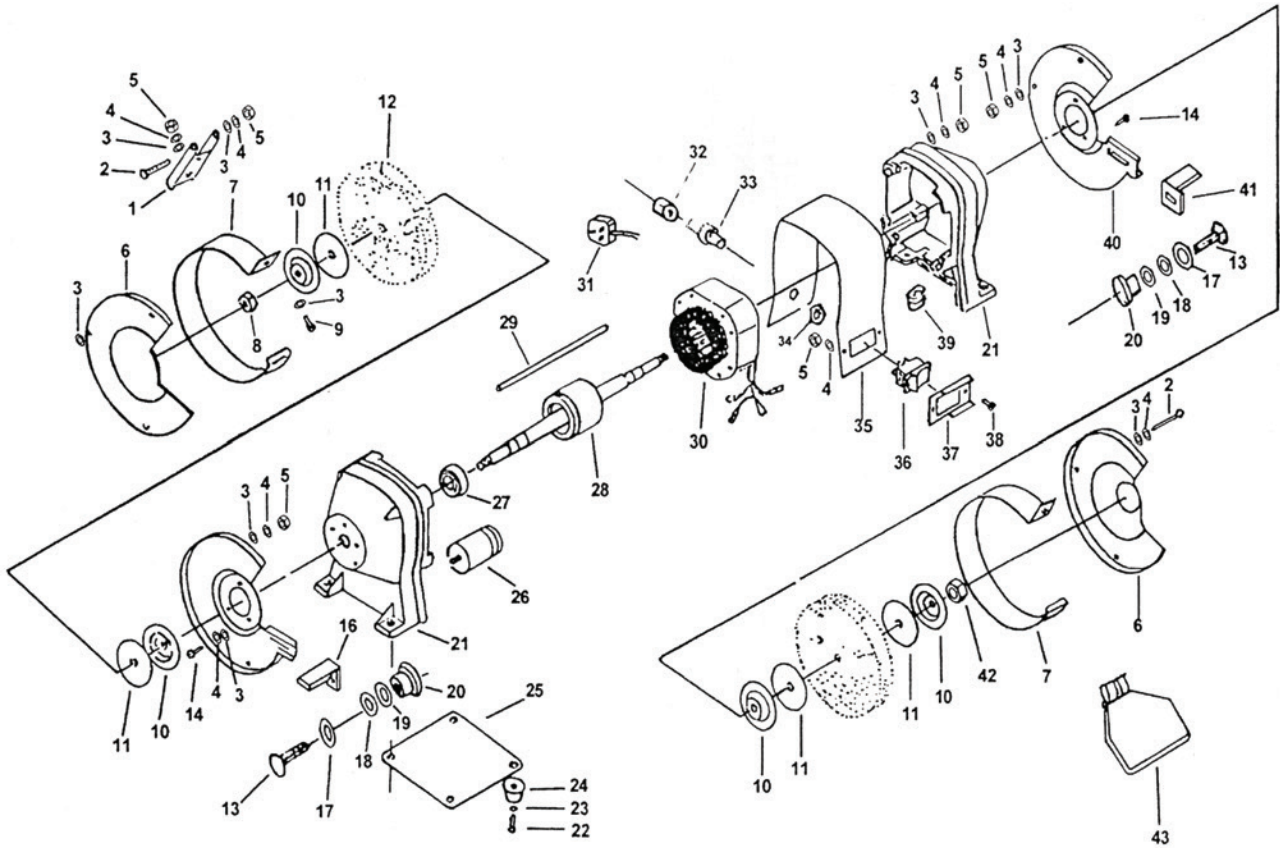

Item	Description
1	Eye Shield Support
2	Screw M5 x 45
3	Washer 5
4	Washer 5
5	Nut M5
6	Protective Cover
7	Motor Guard
8	Nut M12
9	Screw M5 x 15
10	Flange
11	Stone Washer
12	Grinding Wheel
13	Screw
14	Screw M5 x 20
15	Protective Lid (Left)
16	Tool Rest (Left)
17	Washer 8
18	Washer 6
19	Washer 6
20	Knob
21	Mounting Bracket
22	Screw M5 x 8

Item	Description
23	Washer 5
24	Rubber Mat
25	Base Plate
26	Capacitor
27	Bearing
28	Rotor
29	Bolt M5 x 135
30	Stator
31	Plug
32	Strain Relief Cap
33	Strain Relief
34	Strain Relief Nut
35	Motor Cover
36	Switch
37	Switch Plate
38	Screw M5 x 10
39	String Release
40	Protective Lid (Right)
41	Tool Rest
42	Nut M12
43	Eye Shield



# EU Declaration of Conformity

**Cert No: EU / RSBG 6 & 8 / 1**

**RECORD POWER LIMITED,**

Unit B, Ireland Industrial Est.  
Adelphi Way, Staveley, Chesterfield, Derbyshire S43 3LS  
declares that the machinery described:-

1. Type: **Bench Grinder**
2. Model No: **RSBG6 & RSBG8**
3. Serial No .....

Conforms with the following directives:-

MACHINERY DIRECTIVE (repealing / replacing Directives)	2006/42/EC EN 61029-1/A11:2010 EN 61029-2-4:2011
LOW VOLTAGE DIRECTIVE and its subsequent amendment	2006/95EC
ELECTROMAGNETIC COMPATIBILITY DIRECTIVE and its subsequent amendments	2004/108EC EN 55014-1/A2:2011 EN 55014-2/A2:2008 EN 61000-3-2/A2:2009 EN 61000-3-3:2008

and conforms to the machinery example for which the  
EC Type-Examination Certificate No. **E8N120552490019/ Z2120552490020/**  
**M8A120552490017/ N8M120552490018/ Z1A120552490016**  
has been issued by **TUV Rheinland Product Safety GmbH,**  
at: TÜV SÜD Product Service GmbH, Zertifizierstelle, Ridlerstrasse 65, 80339 München, Germany

and complies with the relevant essential health and safety requirements.

Signed..........Dated: **01/02/12**

**Andrew Greensted**  
Managing Director







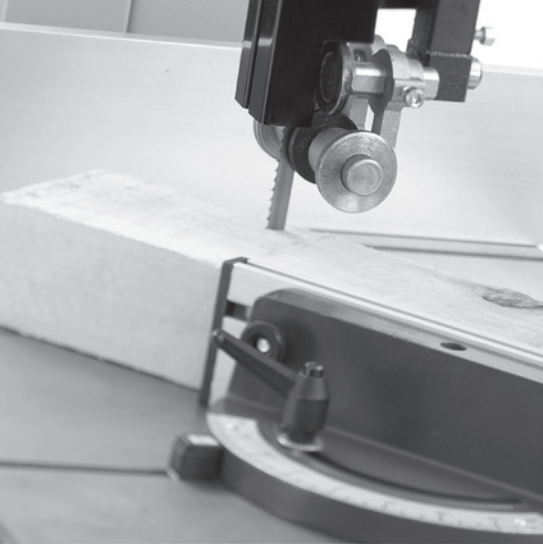

Over  
**100**  
years  
Experience • Knowledge  
Support • Expertise

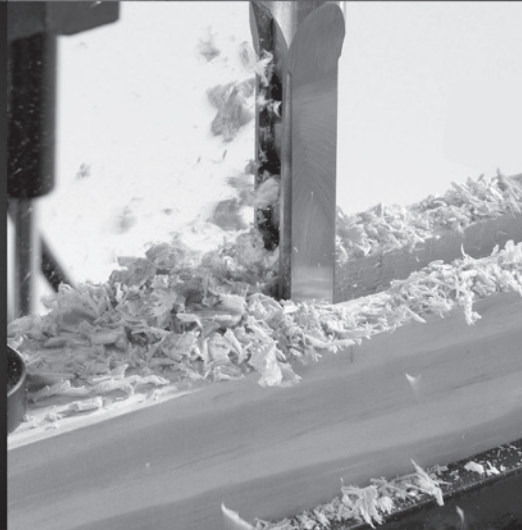

# **RECORD POWER**

ESTABLISHED 1909®

## Woodworking Machinery & Accessories

### **United Kingdom**

#### **Record Power Ltd**

Unit B Adelphi Way, Ireland  
Industrial Estate, Staveley,  
Chesterfield, Derbyshire S43 3LS

Tel: 01246 561 520

[www.recordpower.co.uk](http://www.recordpower.co.uk)

### **Eire**

#### **Record Power Ltd**

Unit B Adelphi Way, Ireland  
Industrial Estate, Staveley,  
Chesterfield, Derbyshire S43 3LS

Tel: 01246 561 520

[www.recordpower.co.uk](http://www.recordpower.co.uk)

### **Australia**

#### **Tools 4 Industry**

Po Box 3844  
Parramatta 2124

Tel: 1300 124 422

Fax: 1800 262 725

[www.recordpower.com.au](http://www.recordpower.com.au)

### **New Zealand**

#### **Tools 4 Industry**

Po Box 276079  
Manukau City 2241

[www.recordpower.co.nz](http://www.recordpower.co.nz)