

# MORETTI®

## PACK CONTENTS

1. Body: 1pc
2. Rubber washer: 1pc
3. Metal washer: 1pc
4. Screw bolt: 1pc
5. Fixing nut: 1pc
6. Copper tails: 2pcs
7. Wrench: 1pc
8. Allen key: 1pc

## Before you start

This mixer is suitable for use at water supply pressures of 0.5 bar minimum. This product must be connected to the water supply in accordance with the Water Supply (Water Fittings) Regulations 1999, and also to comply with the UK Building Regulations. If you are in any doubt about these requirements contact a qualified plumber, your local Water Company, or the Water Regulations Advisory Service (WRAS).

- (a) Identify all components and check pack contents.
- (b) Turn off water mains supply. The main stopcock is usually situated where the supply enters the building.
- (c) It is also recommended that the water heating arrangements are turned off.
- (d) Drain the cold and hot water system. It is recommended to ensure complete drainage, that all taps are opened. There is no need to drain the heating system

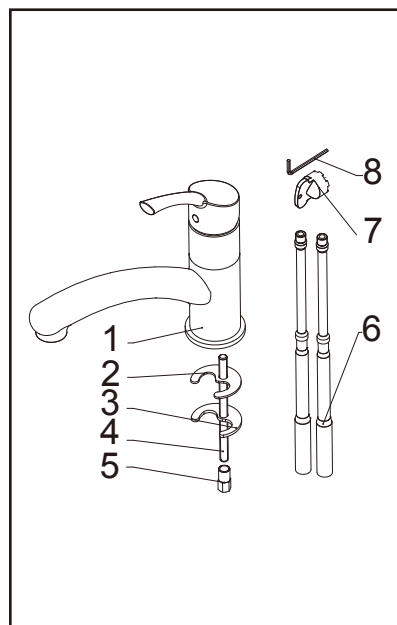

## Fitting Instructions

### Romano Mono Mixer

1. Fit and tighten screw bolt (4) to body (1).
2. Screw 2 x copper tails (6) into the body.
3. Locate the assembled body (1) down through hole in sink.
4. Fit rubber washer (2) and metal washer (3) onto screw bolt (4) below the sink. Now fit the fixing nut (5) onto screw bolt (4). Do not over-tighten.
5. Connect the hot and cold water supplies with copper tails (6) by using suitable plumbing joints.
6. Turn on the main water supply and re-fill the system, check immediately for leaks. It is advisable at this stage to flush out the system. To do this open the valve fully and allow water to flow for approximately one minute. This will remove any foreign matter within the tap body.
7. Finally turn on all water heating arrangements.

Note: The plastic wrench (7) is for disassemble aerator.

## After Care

To maintain the appearance of this fitting, ensure it is cleaned only using a clean soft damp cloth. A solution of warm water and mild liquid detergent may be used where necessary and then rinsed thoroughly. Abrasive cleaners or acidic cleaners MUST NOT BE USED under any circumstances.

Avoid contact with solvents.