

# TECHNICAL DATASHEET

# BRISTAN

## Qubo Kitchen Sink Mixer

### Product Specification

Product Code:	QB SNK C
Finish:	Chrome
Product Type:	Contemporary
Construction:	Body is of brass construction and is designed to conform to BS EN 200
Valve Type:	¼ Turn 3/8" ceramic disc valves
Supply:	Suitable for all plumbing systems
Inlet Connections:	Screw in flexible connecting pipes with 15mm compression ends
Working Pressures:	Min 1bar, Max 5.0bar

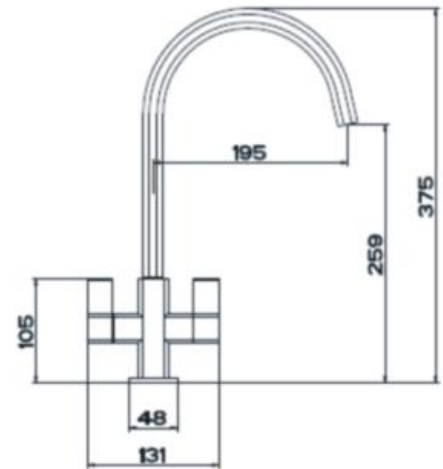

### Additional Information

- Single flow.
- Chrome plated to BS EN 248.
- Available in Chrome only

Technical Advice:	For further information please call 0844 701 6273 or email <a href="mailto:customercare@bristan.com">customercare@bristan.com</a> .
Guarantee:	5 years covering manufacturing faults.

System Pressure	0.2bar	0.5bar	1bar	2bar	3bar	5bar
Sink Mixer (Mixed)	4.9	7.6	10.7	15.0	18.2	23.7

Bristan, Birch Coppice Business Park, Dordon, Tamworth, B78 1SG  
Telephone: 0844 701 6274 Facsimile: 0844 701 6275  
Web Site: [www.bristan.com](http://www.bristan.com) Email: [enquire@bristan.com](mailto:enquire@bristan.com)



D2

# BRISTAN

## Qubo Kitchen Sink Mixer

### Fitting Instructions & Contents List

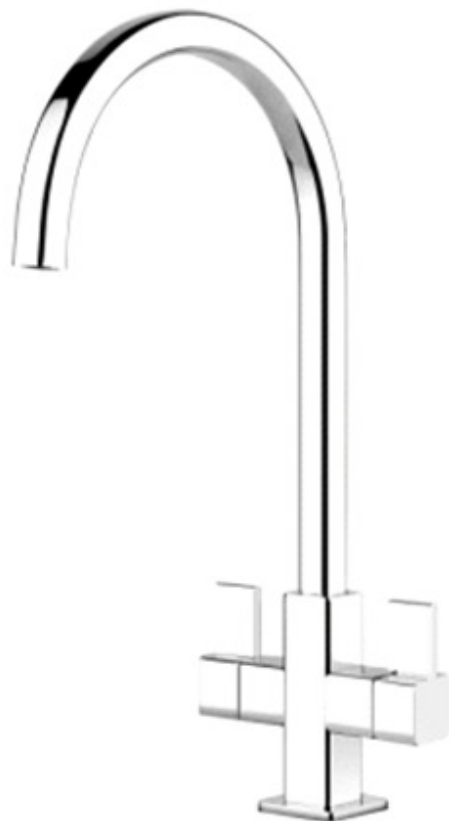

Please keep these instructions for future reference and request of replacement parts

# BRISTAN

## Contents

Thank you for choosing Bristan, the UK's leading taps and showers expert. We have designed this product with your enjoyment in mind. To ensure that it works to its full potential, it needs to be fitted correctly. These fitting instructions have been created to give you all of the information you need and, if you need any further help, please do not hesitate to give us a call on 0844 701 6273.

Important Safety Information	03
General Specifications	03
Installation Requirements	04
Installation	05
Maintenance	06
Guarantee	07

## Important Safety Information

- Please read these instructions thoroughly and retain for future use.
- All products manufactured and supplied by Bristan are safe provided they are installed, used correctly and receive regular maintenance in accordance with these instructions
- **If you are in any doubt about your ability to install this product safely you must employ the services of an experienced qualified plumber.**
- Remove all packaging and check the components for damage before starting installation.
- This product **must** not be modified in any way as this will invalidate the guarantee.
- These fittings need to be installed in accordance with and meet the requirements of the Water Supply (Water Fittings) Regulations 1999 and Scottish Byelaws 2004.

## General Specifications

	Min	Max
Operating pressure range (bar)	1.0	5.0
Maximum static pressure –	10.0 bar	

NOTE:- Nominally equal (balanced) inlet supply pressures are recommended for optimum Performance of mixer taps. If pressures are unequal, then a pressure reducing valve should be used.

Designed to comply with BS EN 200 for single taps/ combination taps for water systems of type 1 and 2 general technical specifications and to be used within systems designed to BS 6700.

BS 6700 recommends the temperature of stored water should never exceed 65°C. A stored water temperature of 60°C is considered sufficient to meet all nominal requirements and will minimize the build up of lime scale in hard water areas.

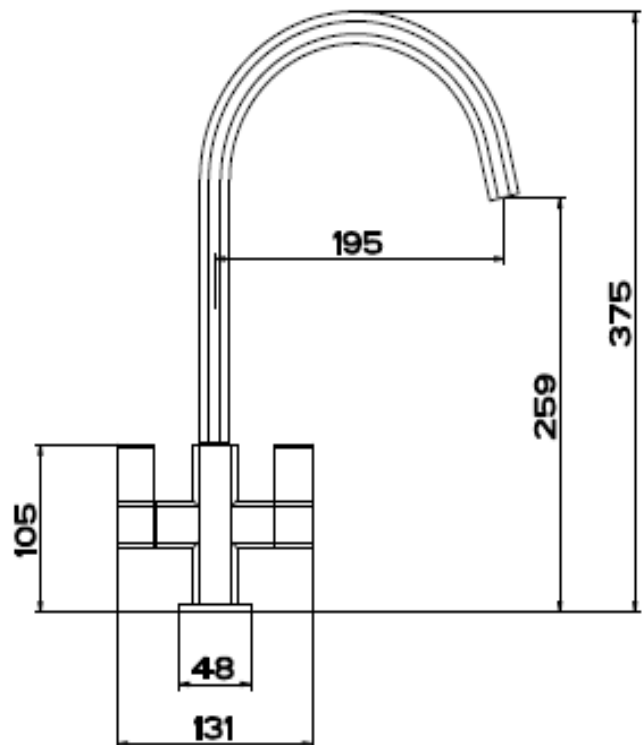

## Installation Requirements

### IMPORTANT - PLEASE READ

This/these fitting/fittings needs/need to be installed in accordance with the following Installation Requirements and Notes (IRN) to ensure they meet the requirements of the Water Supply (Water Fittings) Regulations 1999 and the Scottish Byelaws 2004.

#### IRN R001

See text of entry for Installation Requirements or Notes.

#### IRN R006

This tap or combination tap assembly has a Type AUK3 air gap and is therefore for installation in any premises to protect against a backflow risk up to a Fluid Category 5.

#### IRN R010

Water supplies shall be a reasonably balanced pressures from a common source (e.g. hot and cold supplies both from the same storage or both from a supply pipe). Where the fitting is supplied from unbalanced supplies (e.g. hot and cold supplies from separate sources) a **'Listed' single check valve** or some other no less effective backflow prevention device shall be fitted immediately upstream of both hot and cold water inlets.

## Installation

**Important:** If the fitting is installed at low pressure (tank fed), then the minimum distance from the underside of the water outlet to the cold water tank should be at least 10 metres to ensure adequate performance.

This mixer should be installed in compliance with Water Regulations. For further details please contact your local Water Authority.

Where the supplies are unbalanced i. e. hot water from the cylinder tank and cold from the mains, approved check valves must be fitted in the supply pipes.

1. Identify all components are present prior to installation.
2. Install the mixer body (1) to the sink, ensuring the plinth (3) is fitted between the mixer body (1) and the sink.
3. Screw the threaded rod (8) into the bottom of the mixer body (1).
4. Slide the washer (4) and triangular spacer (6) onto the threaded rod (8) up to the underside of the sink.
5. To secure the mixer in place tighten the fixing nut (7) onto the threaded rod (8) until it is fully tightened against the triangular spacer (6).
6. Screw in the flexible connecting pipes (9) by **hand only (DO NOT OVERTIGHTEN)**.
7. Connect the hot and cold water supplies, and operate the handles in both directions letting the water flow for a few minutes to check all joints and connections for any leaks.

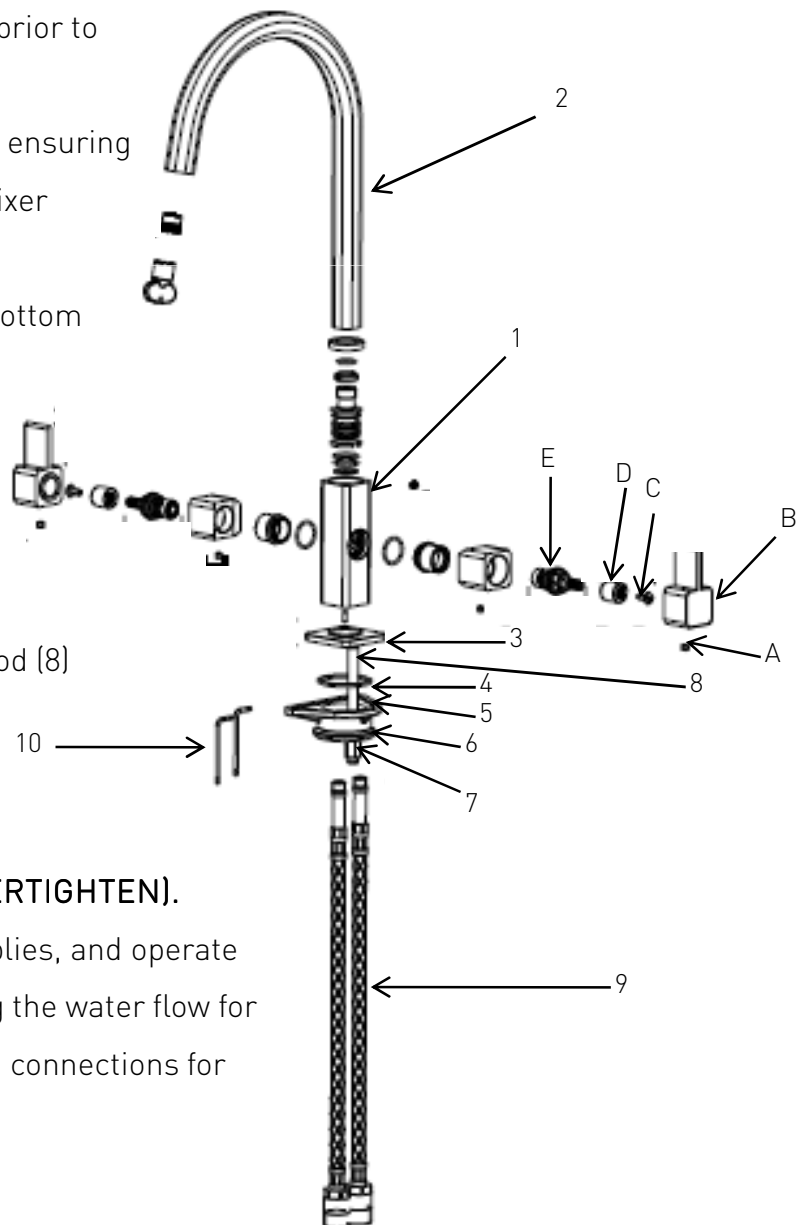

## Maintenance

### General Cleaning

Your fitting has a high quality finish and should be treated with care to preserve the visible surfaces. All finishes will wear if not cleaned correctly. The only safe way to clean your product is to wipe with a soft damp cloth. Stains can be removed using washing up liquid. All bathroom cleaning products (powders and liquids) will damage the surface of your fitting, even the non – scratch cleaners.

**Note:** Never use abrasive detergents or disinfectants or those containing alcohol, hydrochloric acid or phosphoric acid.



Bristan recommend E-cloth for cleaning all of our bathroom & kitchen products. Using just water, E-cloth gives a smear free, deep clean by breaking up and holding dirt, which normal cloths leave behind. Order through your Bristan stockist (order code: E CLOTH).

### Maintenance

We advise that your fitting is regularly serviced in hard water areas to maintain optimum performance.

If your fitting begins to leak the following should be carried out.

Isolate both hot and cold water supplies to the mixer valve by either:

- Turning the water supply off at the mains stopcock or
- Turning off the isolation valves to the mixer valve.

1. Unscrew the grub screw (1) on the underside of the handle (2).

2. Pull the handle from the spline of the valve (3).

3. Unscrew the valve using a suitable spanner.

4. Carefully clean the valve and valve seating

5. If necessary replace the valve

6. Fit the valve back into the tap body and tighten fully using a suitable spanner

6. Push the handle (2) back onto the valve spline and replace the grub screw (1).

If the problem persists please contact our customer services helpline quoting the product code.

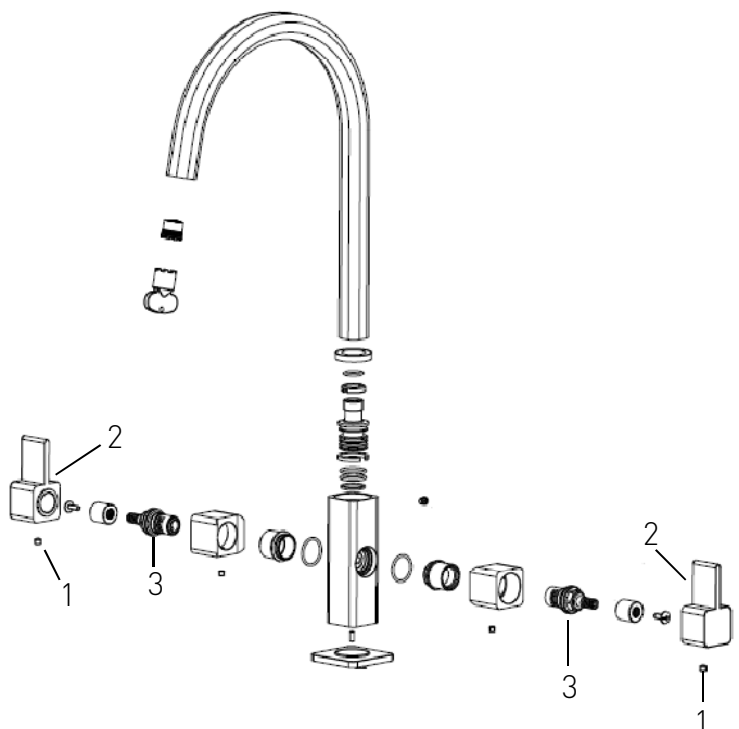

## Bristan Guarantee

Bristan offers solid guarantees to provide you with complete peace of mind.

### Taps and Mixers

5 year parts and 1 year labour\*. Gold, painted and special finishes 3 years parts only.

All subject to proof of purchase.



**Guarantee**

\*Labour provided by an approved Bristan engineer. Guarantee only applies to products with a manufacturing fault. A deferred payment will be necessary in order to secure any visits by our engineers which will be charged if the problem is found **not** to be a manufacturing fault. If the fault is found to be down to a manufacturing error, the payment will be released and not charged.

This guarantee applies to products purchased within the United Kingdom or Republic of Ireland, but does not apply to products used commercially.

The guarantee is only available to original purchasers who have proof of purchase.

The installation must allow ready access to all products for the purpose of inspection, maintenance or replacement.

Any part found to be defective during the above guarantee period will be replaced without charge, providing that the product has been installed in accordance with the instructions, used as intended, and regularly serviced.

Servicing should be carried out at regular intervals of no more than 12 months and more frequently in hard water areas (heavy lime scale) areas.

In the unlikely event that any problems are encountered with the product's performance on installation, you must obtain guidance/authorisation from our Customer Service Department, and be able to supply proof and date of purchase, before any remedial action is taken.

The guarantee excludes general wear and tear and damage caused by accident, misuse or neglect, and does not cover the following:

- Components that are subject to general wear and tear such as filters, seals, 'O' rings and washers etc.
- Damage caused by faulty installation
- Damage caused by lime scale or any waterborne debris
- Damage caused by inappropriate cleaning products (see user instructions)
- Damage caused by the use of non-Bristan parts
- The product being used for a purpose other than intended by the manufacturer.

In the interests of continuous product improvement Bristan reserves the right to alter specification as necessary.



# BRISTAN

This booklet covers product code

QB SNK C

**Helpline**

**0844 701 6273**

Bristan Group Limited

Birch Coppice Business Park, Dordon, Tamworth, Staffordshire B78 1SG

A Masco Company

Website: [www.bristan.com](http://www.bristan.com)

Telephone: 0844 7016 274      Facsimile: 0844 701 6275

Email: [enquire@bristan.com](mailto:enquire@bristan.com)