

TITAN[®]



24 month
Manufacturer's
Warranty

SAFETY AND OPERATING MANUAL

Original instructions

JIG SAW 750W

TTB285JSW



Congratulations on your purchase of a **TITAN power tool from Titan Power Tools (UK) Ltd. We want you to continue getting the best performance from it so this handbook includes information on safety, handling and care. Please retain this handbook in case you need to refer to any of the information in the future.**

Your **TITAN power tool comes with a 24-month guarantee, so should it develop a fault within this period contact your retailer.**

GUARANTEE

This **TITAN** product carries a guarantee of 24 months. If your product develops a fault within this period, you should, in the first instance contact the retailer where the item was purchased.

This guarantee specifically excludes losses caused due to:

- Fair wear and tear
- Misuse or abuse
- Lack of routine maintenance
- Failure of consumable items (such as batteries)
- Accidental damage
- Cosmetic damage
- Failure to follow manufacturer's guidelines
- Loss of use of the goods

This guarantee does not affect your statutory rights. This guarantee is only valid in the UK.

For any enquiries relating to the guarantee please refer to your retailer.



GENERAL SAFETY INSTRUCTIONS



WARNING! Read all safety warnings designated by the symbol  and all instructions.



WARNING! Read all safety warnings and all instructions. Failure to follow the warnings and instructions may result in electric shock, fire and/or serious injury. **Save all warnings and instructions for future reference.**

The term "power tool" in the warnings refers to your mains-operated (corded) power tool or battery-operated (cordless) power tool.

1. Work area safety

- a. **Keep work area clean and well lit.** Cluttered or dark areas invite accidents.
- b. **Do not operate power tools in explosive atmospheres, such as in the presence of flammable liquids, gases or dust.** Power tools create sparks which may ignite the dust or fumes.
- c. **Keep children and bystanders away while operating a power tool.** Distractions can cause you to lose control.

2. Electrical safety

- a. **Power tool plugs must match the outlet. Never modify the plug in any way. Do not use any adapter plugs with earthed (grounded) power tools.** Unmodified plugs and matching outlets will reduce risk of electric shock.
- b. **Avoid body contact with earthed or grounded surfaces, such as pipes, radiators, ranges and refrigerators.** There is an increased risk of electric shock if your body is earthed or grounded.
- c. **Do not expose power tools to rain or wet conditions.** Water entering a power tool will increase the risk of electric shock.
- d. **Do not abuse the cord. Never use the cord for carrying, pulling or unplugging the power tool. Keep cord away from heat, oil, sharp edges or moving parts.** Damaged or entangled cords increase the risk of electric shock.
- e. **When operating a power tool outdoors, use an extension cord suitable for outdoor use.** Use of a cord suitable for outdoor use reduces the risk of electric shock.
- f. **If operating a power tool in a damp location is unavoidable, use a residual current device (RCD) protected supply.** Use of an RCD reduces the risk of electric shock.

3. Personal safety

- a. **Stay alert, watch what you are doing and use common sense when operating a power tool. Do not use a power tool while you are tired or under the influence of drugs, alcohol or medication.** A moment of inattention while operating power tools may result in serious personal injury.
- b. **Use personal protective equipment. Always wear eye protection.** Protective equipment such as dust mask, non-skid safety shoes, hard hat, or hearing protection used for appropriate conditions will reduce personal injuries.
- c. **Prevent unintentional starting. Ensure the switch is in the off-position before connecting to power source and/or battery pack, picking up or carrying the tool.** Carrying power tools with your finger on the switch or energising power tools that have the switch on invites accidents.

JIG SAW 750W

TTB285JSW

d. Remove any adjusting key or wrench before turning the power tool on. A wrench or a key left attached to a rotating part of the power tool may result in personal injury.

e. Do not overreach. Keep proper footing and balance at all times. This enables better control of the power tool in unexpected situations.

f. Dress properly. Do not wear loose clothing or jewellery. Keep your hair, clothing and gloves away from moving parts. Loose clothes, jewellery or long hair can be caught in moving parts.

g. If devices are provided for the connection of dust extraction and collection facilities, ensure these are connected and properly used. Use of dust collection can reduce dust-related hazards.

4. Power tool use and care

a. Do not force the power tool. Use the correct power tool for your application. The correct power tool will do the job better and safer at the rate for which it was designed.

b. Do not use the power tool if the switch does not turn it on and off. Any power tool that cannot be controlled with the switch is dangerous and must be repaired.

c. Disconnect the plug from the power source and/or the battery pack from the power tool before making any adjustments, changing accessories, or storing power tools. Such preventive safety measures reduce the risk of starting the power tool accidentally.

d. Store idle power tools out of the reach of children and do not allow persons unfamiliar with the power tool or these instructions to operate the power tool. Power tools are dangerous in the hands of untrained users.

e. Maintain power tools. Check for misalignment or binding of moving parts, breakage of parts and any other condition that may affect the power tool's operation. If damaged, have the power tool repaired before use. Many accidents are caused by poorly maintained power tools.

f. Keep cutting tools sharp and clean. Properly maintained cutting tools with sharp cutting edges are less likely to bind and are easier to control.

g. Use the power tool, accessories and tool bits etc. in accordance with these instructions, taking into account the working conditions and the work to be performed. Use of the power tool for operations different from those intended could result in a hazardous situation.

5. Service

a. Have your power tool serviced by a qualified repair person using only identical replacement parts. This will ensure that the safety of the power tool is maintained.

ADDITIONAL SAFETY INSTRUCTIONS FOR YOUR JIG SAW

1. **Hold power tool by insulated gripping surfaces, when performing an operation where the cutting accessory may contact hidden wiring or its own cord.**

Cutting accessory contacting a "live" wire may make exposed metal parts of the power tool "live" and could give the operator an electric shock.

2. Always use eye glasses and dust mask.
3. Hearing protection should be worn when using jigsaw.
4. Do not use damaged or worn blades.
5. Always use jigsaw with guard cover down.
6. Regularly check the two screws in the blade clip.
7. Regularly check the adjustment of the support roller.
8. Do not run the machine with any part of the casing missing or damaged.
9. If blade is jammed in work piece, do not start the jigsaw.



WARNING! Some dust particles created by power sanding, sawing, grinding, drilling and other construction jobs contain chemicals known to cause cancer, birth defects or other reproductive harm. Some examples of these chemicals are:

- Lead from lead-based paints.
- Crystalline silica from bricks and cement and other masonry products.
- Arsenic and chromium from chemically treated timber.

Your risk from these exposures varies, depending upon how often you do this type of work. To reduce your exposure to these chemicals:

- Work in a well ventilated area.
- Work with approved safety equipment, such as those dust masks that specially designed to filter out microscopic particles and use the dust extraction facility at all times.

SAFETY POINTS FOR YOUR LASER

Do not stare directly at the laser beam. A hazard may exist if you deliberately stare into the beam, please observe all safety rules as follows:

1. The laser device fitted to this tool is class 2 with a maximum radiation of **1mW and 650nm** wavelength. These lasers do not normally present an optical hazard although staring at the beam may cause flash blindness.
2. The laser shall be used and maintained in accordance with the manufacturer's instructions.
3. Never aim the beam at any person or an object other than the work piece.
4. The laser beam shall not be deliberately aimed at another person and shall be prevented from being directed towards the eye of a person for longer than 0.25 seconds.
5. Always ensure the laser beam is aimed at a sturdy work piece without reflective surfaces, e.g wood or rough coated surfaces are acceptable.
Bright shiny reflective sheet steel or similar is not suitable for laser applications as the reflective surface may direct the laser beam back at the operator.
6. Do not change the laser device with a different type. Repairs must be carried out by the manufacturer or an authorised agent.



CAUTION! Use of controls or adjustments other than those specified herein may result in hazardous radiation exposure.

JIG SAW 750W

TTB285JSW

VIBRATION

The European Physical Agents (Vibration) Directive has been brought in to help reduce hand arm vibration syndrome injuries to power tool users. The directive requires power tool manufacturers and suppliers to provide indicative vibration test results to enable users to make informed decisions as to the period of time a power tool can be used safely on a daily basis and the choice of tool.

Further Advice can be found at www.hse.gov.uk

Work mode description	Vibration total values (triax vector sum) determined according to EN60745:
Vibration for cutting wood $a_{h,CW}$	11.139m/s ² K= 1.5m/s ²
Vibration for cutting sheet metal $a_{h,CM}$	9.074m/s ² K= 1.5m/s ²

The declared vibration emission value should be used as a minimum level and should be used with the current guidance on vibration.

Calculating the actual period of the actual period off use can be difficult and the HSE website has further information.

The declared vibration emission has been measured in accordance with a standardised test stated above and may be used to compare one tool with another.

The declared vibration emission value may also be used in a preliminary assessment of exposure.



Warning: The vibration emission value during actual use of the power tool can differ from the declared value depending on the ways in which the tool is used dependant on the following examples and other variations on how the tool is used:
 How the tool is used and the materials being cut.
 The tool being in good condition and well maintained
 The use the correct accessory for the tool and ensuring it is sharp and in good condition.
 The tightness of the grip on the handles.
 And the tool is being used as intended by its design and these instructions.

This tool may cause hand-arm vibration syndrome if its use is not adequately managed



Warning: identify safety measures to protect the operator that are based on an estimation of exposure in the actual conditions of use (taking account of all parts of the operating cycle such as the times when the tool is switched off and when it is running idle in addition to the trigger time).Note The use of other tools will reduce the users' total working period on this tool.

Helping to minimise your vibration exposure risk.

ALWAYS use sharp blades.

Maintain this tool in accordance with these instructions and keep well lubricated (where appropriate)

Avoid using tools in temperatures of 10°C or less

Plan your work schedule to spread any high vibration tool use across a number of days.

Health Surveillance

All employees should be part of an employer's health surveillance scheme to help identify any vibration related diseases at an early stage, prevent disease progression and help employees stay in work.

Double insulation: 

The tool is double insulated. This means that all the external metal parts are electrically insulated from the mains power supply. This is done by placing insulation barriers between the electrical and mechanical components making it unnecessary for the tool to be earthed.

Important note:

Be sure the supply is the same as the voltage given on the rating plate. The tool is fitted with a two-core cable and plug.

Always remove the mains plug from socket before carrying out any adjustment or servicing.

JIG SAW 750W

TTB285JSW

SYMBOLS



To reduce the risk of injury, user must read instruction manual



Warning



Waste electrical products should not be disposed of with household waste. Please recycle where facilities exist. Check with your Local Authority or retailer for recycling advice.



Wear ear protection



Wear eye protection



Wear dust mask



Double insulation



Do not stare into beam



Conform to European standards



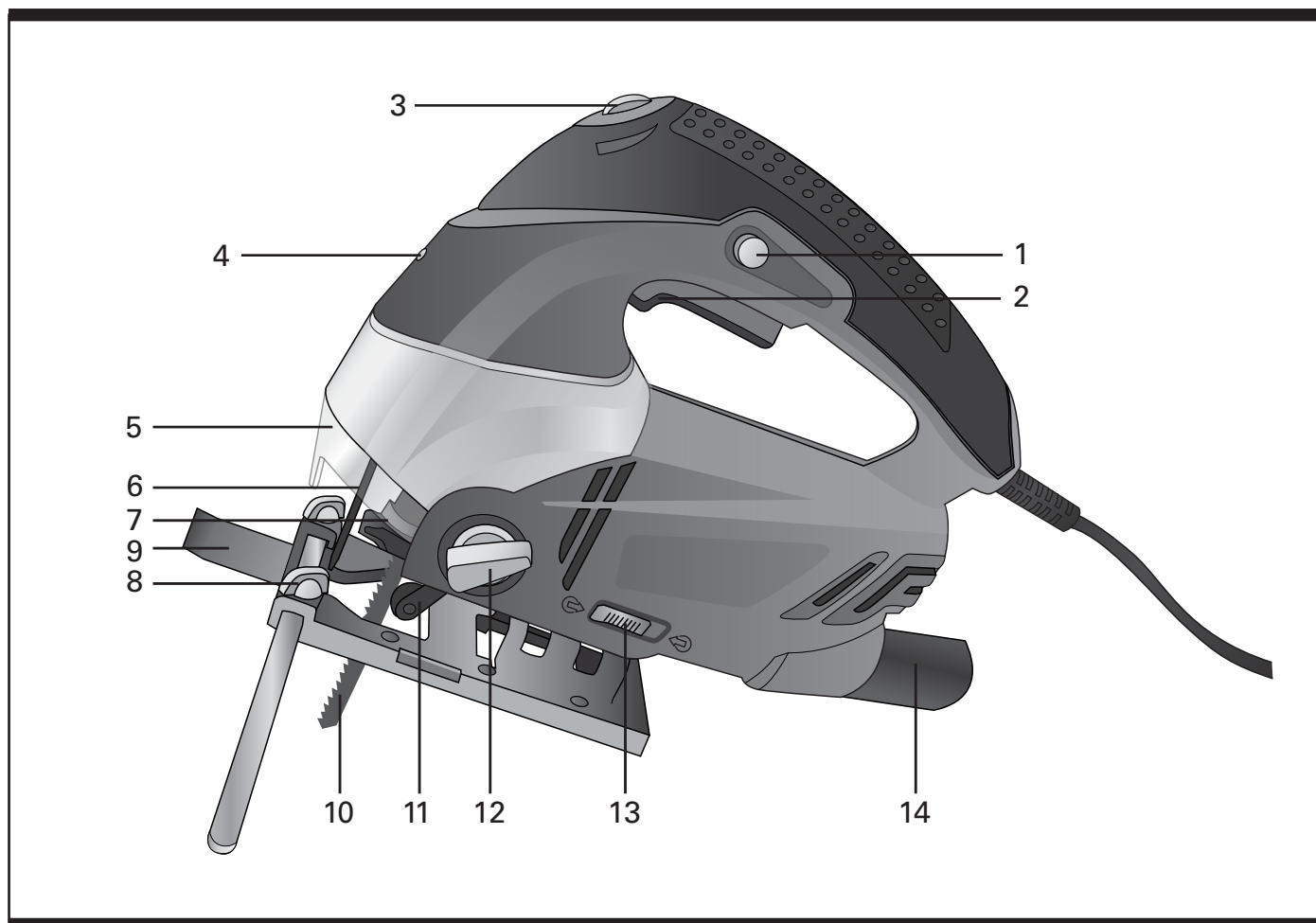

- 1 Lock on switch**
- 2 Trigger switch**
- 3 Variable speed control wheel**
- 4 Laser/LED light on/off switch**
- 5 Laser generator/LED light**
- 6 Wire frame safety guard**
- 7 Blade holder**
- 8 Parallel guide fixture**
- 9 Parallel guide**
- 10 Saw Blade**
- 11 Guide roller**
- 12 Pendulum action switch**
- 13 Vacuum/Blower selector**
- 14 Dust extraction adaptor**

JIG SAW 750W

TTB285JSW

TECHNICAL DATA

Voltage:	230-240V~ 50Hz
Input power:	750W
No load speed:	800-3000/min
Blade types:	"T" and "U" shank
Maximum cutting depth:	100mm (wood) 20mm (aluminium) 10mm (steel)
Protection class:	II
Machine weight:	2.7kg

LASER INFORMATION

Laser class:	Class 2
Wavelength:	650nm
Output power:	≤1 mW
Energy source:	built in transformer

NOISE DATA

A weighted sound pressure	90.8dB(A) / KpA: 3dB(A)
A weighted sound power	101.8dB(A) / KwA: 3dB(A)
Wear ear protection when sound pressure is over	80dB

ACCESSORIES

Blade	6pcs (2pcs for metal, 2pcs for wood, 2pcs for aluminium)
Parallel guide	1pc
Dust extraction adaptor	1pc
Hex key	1pc

OPERATIONS INSTRUCTIONS



Note: Before using the tool, read the instruction book carefully.

INTENDED USE

This jigsaw shall be used for cutting metal or wood or similar materials.

Other uses for the tool will lead to the damage of the tool and a series of dangers to the operator. This tool is intended for DIY home use, or occasional professional use.

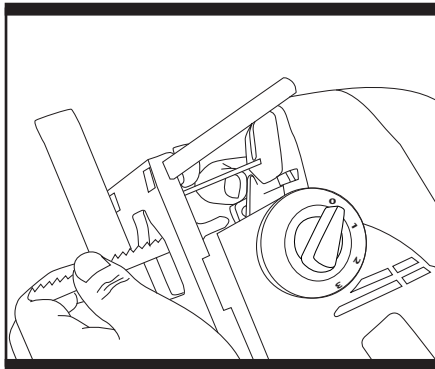

Fig. 1

1. Fitting the Saw Blade (Fig. 1)

WARNING. Switch off the jigsaw and unplug from power point before fitting blades.

Note: When changing blades, set pendulum action switch to "0".

Your jigsaw is equipped with a toolfree blade holder. To open the blade holder, push the ring (jigsaw upside down) and hold in position. Then fully insert the blade into the blade holder slot with blade teeth facing forward and release the ring, which will clamp over the top of the blade. Push the blade into the blade holder again to ensure it is locked in position. Ensure the edge of the blade is located in the groove of the support roller. To remove blade, hold the blade and push the ring then lift out the blade.

Warning:

- Blade teeth are very sharp.
- For best cutting result, ensure you use a blade suited to the material and cut quality you need.

JIG SAW 750W

TTB285JSW

2. Using the parallel guide (Fig. 2)

Parallel guide can be used for making cuts parallel to a work piece edge at a chosen distance. Slide the parallel guide arm through the slot and tighten the screw (8) to lock it into position.

This guide can be used from both sides of the base plate.

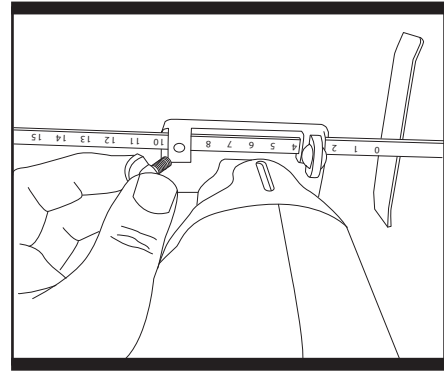



Fig. 2

3. Vacuum and blower selector (Fig. 3)

Slide backward the vacuum/blower selector to position  to blow away dust and chips in cutting area. Slide forward the selector to position  while connected to a dust extraction system or household vacuum.

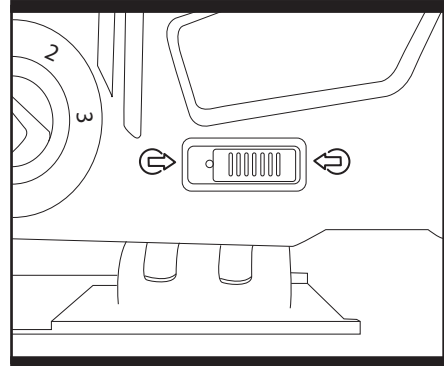



Fig. 3

4. Dust extraction (Fig. 4)

To improve dust extraction from the working area, insert the dust extraction adaptor to the dust extraction outlet of the jigsaw, turn clockwise to secure it, and then connect to a dust extraction system or a suitable vacuum cleaner. Slide forward the selector to position .

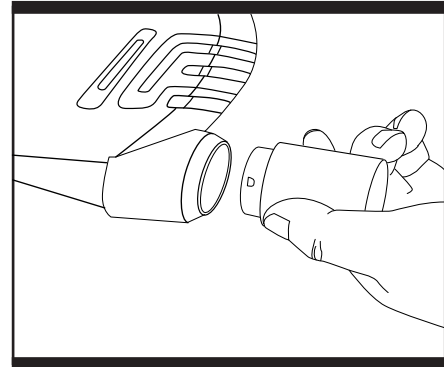

Fig. 4

Warning: Do not use a dust extraction system or a vacuum cleaner when cutting metal. Sparks may ignite residual wood dust.

5. Operating the trigger switch (Fig. 5)

To operate the Pendulum Jigsaw, depress the trigger switch. If you wish to use the Pendulum Jigsaw continuously, the trigger lock button can be pushed in after the trigger switch has been depressed. To release the lock button push in the trigger switch again.

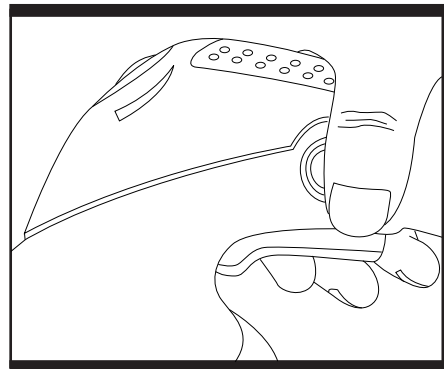

Fig. 5

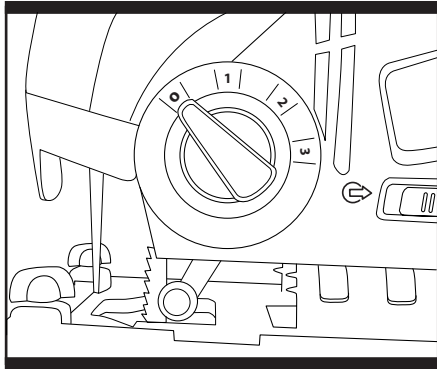

Fig. 6

6. Pendulum action switch adjustment (Fig. 6)

The adjustable 4-stage pendulum action makes it possible to adjust the blade penetration on the upward stroke for the various working materials. Optimal cutting performance is thereby achieved. The saw blade is lifted from the workpiece on the downward stroke. This results in improved chip ejection while substantially reducing frictional heat and increasing the life expectancy of the saw blade. The pendulum action can be adjusted to one of four stages with pendulum action knob. The setting can be changed while the machine is operating:

Stage 0: Pendulum action off

Stage 1: Low pendulum action

Stage 2: Moderate pendulum action

Stage 3: High pendulum action

The following should be observed

- The pendulum action should be off when working with thin materials such as sheet metal.
- If smoothly cut edges are desired in soft material, select low stage or shut off pendulum action.
- Use low pendulum action when working with hard materials such as steel.
- Use high pendulum action when working with most soft materials such as wood and plastic.

The optimum setting can be determined in practical trials on scrap material.

JIG SAW 750W

TTB285JSW

7. Speed selection (Fig. 7)

With the thumbwheel, the required speed rate can be selected (also while running).

MIN-1 = Low speed rate: for metals other than aluminium

2-4 = Medium speed rate: for aluminum and PVC

5-MAX = High speed rate: for wood

The speed rate required depends upon the material and the working conditions: fast enough to make reasonable progress, but slow enough to keep a clean cut and to avoid straining the machine. Generally, finer saw blades use a higher speed, coarser blades use a slower speed.

After working for longer periods at low speed rate allow the machine to cool by running it at maximum speed rate and no load for approx 3 minutes.

8. Using the pendulum jigsaw

Switch on and wait until blade has reached maximum speed. Place the front of the baseplate on the workpiece and line up the cutting line with the line you wish to cut.

Push slowly forward. Keep the baseplate flat against the workpiece.

- Cutting metal

An appropriate cutting agent (such as light oil, small amounts of soapy water, etc.) should always be used. If there is no available liquid cutting agent, grease can be applied to the back surface of the material to be cut. Never use flammable liquids when cutting.

- Cutting grooves/window holes

For wood: Align the blade direction with the grain of the wood. Then position the rounded part at the front of the base plate on surface to be cut, slowly lower the saw into material at chosen point of entry. Lower the saw in a pivoting action until blade has cut through to other side, do not move saw along intended cut line until the blade has cut through and base plate is laying flat on material.

For other materials: In materials other than wood when cutting window holes, first use a drill or similar tool to drill a hole from which initial cutting will begin.

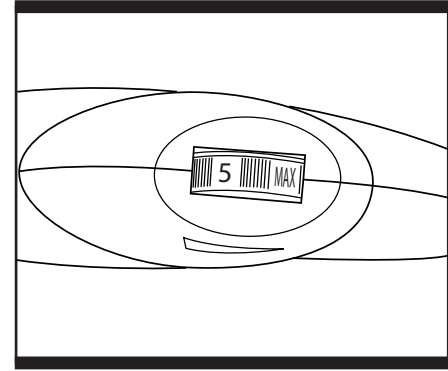

Fig. 7

9. Angular cutting (Fig. 8)

To adjust the base plate bevel angle, loosen the screws located under the base plate with the hex key (Fig. 9). Move the base plate backwards so that the teeth at the front no longer engage with the retaining spigot and the base plate can be tilted to the left or right. If the required angle is 15°, 30° or 45° to the left or right or 0°, push the base plate forwards so that the appropriate teeth on the plate mesh with the spigot. Hold the base plate at the desired angle and firmly tighten the screws with the key.

Bevel angles are stamped onto the bracket on the underside of the base. For accurate work it is may be necessary to make a trial cut.

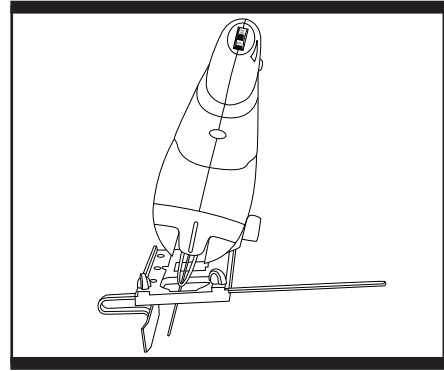

Fig. 8

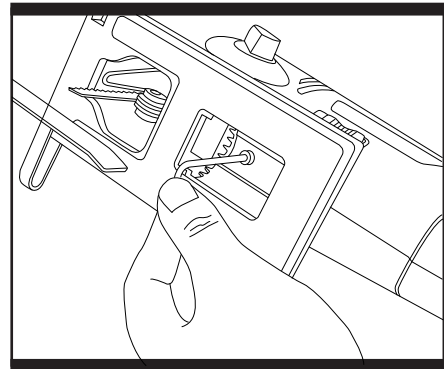

Fig. 9

10. Using the laser and LED light (Fig. 10)

1. To use LED light, simply press down the Laser/LED light on/off switch.
2. If you push a second time, the LED light switches off and the laser on.
3. If you push another time, both laser and LED are working.
4. Push again the Laser/LED light on/off switch to stop the laser & LED light.

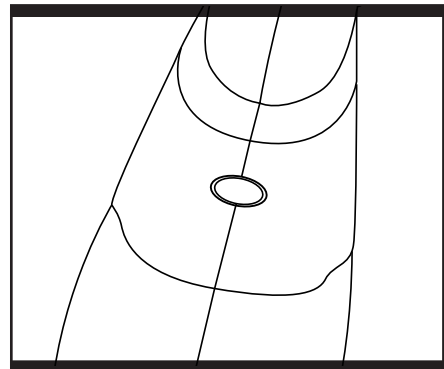

Fig. 10

Note:

- The saw dust may block the laser beam, clean the laser generator periodically.
- Switch off the laser when you stop the machine.
The laser does not switch off automatically.



Caution: Switch off the laser when stop the machine. Never stare directly into the laser beam and never point the beam at anybody.

JIG SAW 750W

TTB285JSW

Working hints for your Jig saw

1. Here is some advice on the pendulum action control: the saw blade is only pressed against the material on the return stroke/working stroke. It is moved away from the material on the forward stroke. The result is better removal of chips, less friction and therefore a higher output.
2. To avoid the jigsaw springing up and down when sawing sheets, support the sheet on timbers. When sawing metal, apply a none flammable coolant oil along the cutting line.
3. Adjust the speed and the pendulum action settings to suit the material to be sawn. We always recommend that you carry out a test cut first.
4. To use the jigsaw put the front end of the base plate on the material and turn the machine on. Press the machine from above on to the material and guide the jigsaw along the cutting line.
5. Do not use too much pressure to achieve the best progress when sawing, use light pressure on the saw blade.
6. When sawing along a marked line use the laser as a guide.
7. For exact cutting, clamp a timber batten on to the material as an aid or use the parallel guide.
8. For mitres/bevels, set the base plate in the required position.
9. Set the base plate to its rearmost position for cutting close to an edge.

MAINTENANCE

Remove the plug from the socket before carrying out any adjustment, servicing or maintenance.

Your power tool requires no additional lubrication or maintenance. There are no user serviceable parts in your power tool. Never use water or chemical cleaners to clean your power tool. Wipe clean with a dry cloth. Always store your power tool in a dry place. Keep the motor ventilation slots clean. Keep all working controls free of dust. Occasionally you may see sparks through the ventilation slots. This is normal.

If the supply cord is damaged, it must be replaced by the manufacturer, its service agent or similarly qualified persons in order to avoid a hazard.

ENVIRONMENTAL PROTECTION



Waste electrical products should not be disposed of with household waste. Please recycle where facilities exist. Check with your Local Authority or retailer for recycling advice. For further information visit www.recyclemore.co.uk

UK PLUG REPLACEMENT

The fuse in the main plug of your power tool should always be replaced with one of identical rating.

Check the voltage given on your power tool matches the supply voltage.

The power tool is supplied with a fitted plug, however if you should need to fit a new plug follows the instruction below.

IMPORTANT

The wire in the mains lead are coloured in accordance with the following code:

Blue ---Neutral

Brown ---Live

The wire that is coloured **blue** must be connected to the terminal that is marked with the letter **N**. The wire that is coloured **brown** must be connected to the terminal that is marked with the letter **L**.

A 13AMP (BS1363 or BS1363/A) plug must be used and a 13 AMP fuse must be fitted.

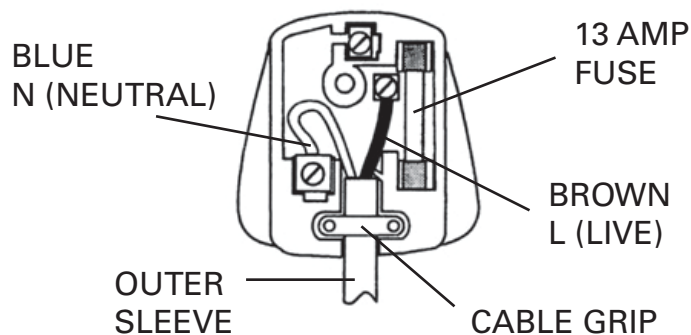

JIG SAW 750W

TTB285JSW



Declaration of Conformity

We, Importer
Titan Power Tools (UK) Ltd
Trade house, Mead Avenue, BA22 8RT

Declare that the product:
Designation: Jig Saw 750W
Model: TTB285JSW

Complies with the following Directives:
2004/108/EC Electromagnetic Compatibility Directive,
2006/42/EC Machinery Directive
2006/95/EC Low Voltage Directive,
2002/95/EC Restrictions of the Use of Certain Hazardous Substances in Electrical and Electronic Equipment
2002/96/EC and 2003/108/EC Waste Electrical and Electronic Equipment (WEEE),

Standards and technical specifications referred to:
EN 60745-1: 2009
EN 60745-2-11: 2003+A11: 2007+A1: 2009+A12: 2009
EN 55014-1: 2006+A1: 2009
EN 55014-2:1997+A1: 2001+A2: 2008
EN 61000-3-2: 2006
EN 61000-3-3: 2008

Authorised Signatory and technical file holder

Date: 28/06/2010

Signature: Peter Harries

Name / title: Peter Harries / Quality Manager

Titan Power Tools (UK)Ltd. Trade House , Mead Avenue ,BA22 8RT

