

1. Before construction of your cabin the complete decking rectangle is made first.
2. Equally space the deck bearers with the 62mm (wide) side to the floor and the outer bearers level with the end of a deck board (Fig D1)



Fig D1

3. Use another deck board as a guide (fig D2) and measure diagonally to ensure squareness and screw the **first deck board only** into position using 2 x 50mm at each bearer.



Fig D2



Fig D3

3. Equally space the decking boards leaving an even gap between each board and screw into position using 40mm screws as before (Fig D3)
4. Place Into position when you have fixed first logs (next section).

12.

SHIRE

BUILT AROUND OUR REPUTATION



EXAMPLE CABIN

PINE LODGE ASSEMBLY INSTRUCTIONS

Thank you and congratulations on the purchase of your pine lodge. We believe that this product will give you many years of excellent service. This is a natural product manufactured to the highest standard therefore if you have any queries or experience any difficulties then please contact our customer service hotline on

01945 46 89 10 01945 46 89 11 01945 46 89 12

Normal office hours: 8.30am to 5.00pm Monday to Friday. Answer phone all other times.

Check all components before assembling your pine lodge or employing trades people

PREPARATION OF BASE

We recommend you construct your pine lodge on a suitable concrete base. It should be at least the same size as the main building without the returns that stick out at the corners (180mm less than the external dimensions on stable ground or the same size as the external dimensions on unstable ground- consult a local expert for advice. It should have a very slight fall to prevent water laying on it.

We do not recommend slab and / or shingle bases as an uneven base or subsequent settling will cause excessive strain and may damage your building and invalidate your warranty.

YOUR BASE MUST BE FLAT AND FIRM!

Treatment/Care of your Log Cabin

ALL TIMBER MUST BE KEPT DRY

We recommend that you treat the entire window and door units including the beading with a top quality timber treatment. Prior to assembly (Fig5, 6 &7) with at least 2 coats as some areas are not accessible after assembly.

Once you have assembled your pine lodge you can then unscrew the back architrave of the window and door units, remove them and you treat all remaining timber with a top quality timber treatment immediately. Re-coat as per your timber treatment instructions.

Note: You will not have to treat the floor bearers, as they are already pressure treated before delivery.

We also recommend that you seal the external log corner joints (where the logs slot together.) with silicone sealant (not supplied) to ensure any damp does not seep into your pine lodge (after assembly).

TOOLS REQUIRED

- Pozidrive Screwdriver (Electric)
- Hammer
- Rubber Mallet
- Sandpaper
- Cutting Knife
- Tape Measure
- Step Ladder
- Pencil
- Saw
- Damp proof strip
- Silicone sealant
- Oil for lock

PLEASE NOTE

Wood is a natural product and is therefore prone to changes in appearance, including some warping, movement and splitting, particularly during unusual climatic conditions (long hot or cold spells of weather). As a natural occurrence this is not covered by our guarantee.

IMPORTANT SAFETY INFORMATION!

- **We recommend the wearing of non-slip protective gloves throughout the assembly process. We also recommend the wearing of steel capped protective shoes, protective head gear, safety glasses and full length clothing. If step ladders are to be used we recommend one person holds the ladder whilst the other is using them. If necessary a third person should be used. Do not attempt to erect the building in windy conditions. Follow any safety precautions quoted by the manufacturer for any equipment you use.**
- **Every precaution has been taken to ensure that your building has no element incorrectly placed or possibly hazardous. However prior to use please check for raised grain or splinters and sand if necessary. Check that all elements are secure against reasonable force.**

Assembly of your log cabin **NOTE** if you have double doors , double windows or tiles see supplement sheets first

A - SETTING OUT

See Drawing pages 1&2

1. Lay out pressure treated base floor joist timbers as fig 1 (It is recommended that you place a piece of damp proof strip under each joist).
2. **34 44 70 log buildings** The external walls parallel to the joists have two joists as in fig2 and need to be fixed together using 70mm nails at a slight angle. This also applies to partition walls.
3. The joist spacing is on drawing page 2
4. Using parts list for each wall lay out correct quantity of each component for relevant wall (i.e. front, back) in suitable position for ease of assembly.
5. **Note some buildings may be supplied with shorter bearers and joiners to make up the length required. Place a joiner next the bearers to be joined and fix with 70mm nails as in step 2**

B - FLOOR BEARERS AND FIRST ROW OF LOGS

1. All logs are fitted with the **tongues upwards**
2. Firstly position the half logs as shown (fig1) on top of the floor bearers



FIG 1

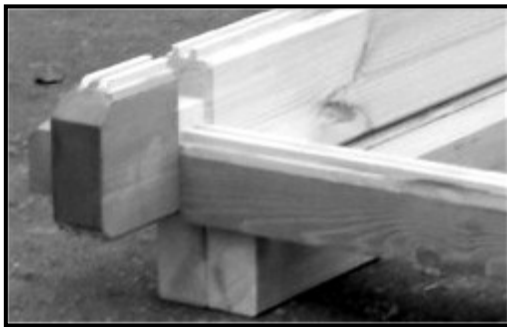

FIG 2

3. Next position 2 logs from the adjacent sides either end of the half logs. Fig 1 and 2

Important

4. Measure corner to corner, as building must be square
5. Also measure length at the centre of the building from wall to wall (A1 to A1) to ensure correct length before fixing to joists (fig3) with 80mm screws.
6. This is the bottom of all four walls; it's now ready to be built upon.

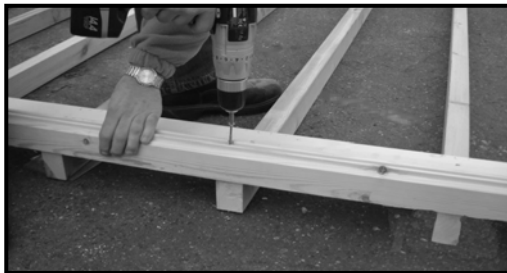

FIG 3

C - WALLS

See drawing pages 2, 3,4,5,6.

1. The walls can now be assembled as per pages 2, 3,4and, 5.
2. Start building walls either anti-clockwise or clock-wise direction.
3. Each log needs to be tapped home to log below using timber block supplied and a rubber mallet (fig4).

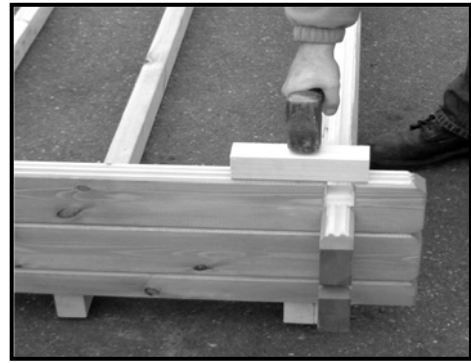

FIG 4

D - INSERTING WINDOWS AND DOORS.

UNDER NO CIRCUMSTANCES MUST THE DOOR OR WINDOW FRAMES BE NAILED TO THE LOGS. The logs must be free to move within the frame lots to allow for expansion and contraction.

Important Notes

Fit door furniture and unlock the door as soon as you fit it so you don't get locked in! FULLY LUBRICATE THE LOCK It is extremely important that you lubricate your lock through the key hole and all moving parts as soon as possible after assembly and at least at monthly intervals thereafter . Also ensure that you regularly operate the lock especially during the winter or when not in use.

1. See supplement sheet for door and window unit assembly.
2. Refer to your drawing pages for the positioning of windows and doors
3. Door and window units must not be fixed to the logs
4. The pictures of the windows are different than those on your building but the same principals are used for fitting them



FIG 5

5. Door unit must be placed into position after the first two layers of full logs have been assembled (fig5). Slide unit into aperture from above ensuring unit is completely down and in position. (Fig 6).
7. **Note** internal doorframes sit on top of the floorboards



FIG 6

8. The window unit is fitted as below.



FIG 7

E - GABLES

See sheets 2A, 3A

1. Assemble the back gable first.
2. The letters on the sheets are viewed as looking from the outside of the building. Once gables are in place (see page 8) ensure bottom of gable meets the top of the side panel
3. If gable is slightly raised from the side panel try to knock down .If still too high plane down, this will ensure the roof boards meet side walls correctly
4. Fix with 80mm screws (fig 8&9). Repeat with the other gables.



FIG 8



FIG 9



Example

F - ROOF

See page 6

1. Fit roof bearers into slots provided in gable sections (fig10).
2. Measure the distance between each roof bearer (in several places); the roof bearers and walls to ensure all components are fully home before continuing



FIG 10

3. It may be necessary to cut the angled eaves edging strips (44x25) to fit between the gable ends (fig11)
4. Position the eaves edging strips level at both ends with the gable angle and screw to the wall with 40mm screws



FIG 11

5. The first roof board is now ready to be positioned,
6. Start at the front with the groove facing the front and Lining up with roof beams (fig12). **Bevelled corner down- outer roof face flat.**
7. Fix into place (At the roof bearers and angled eaves edgings) with 2 **40mm round head nails at an opposing angle (vee) to each other at each point.**



FIG 12

8. Fit the remaining roof boards along one side of the roof **as above.**
9. The final roof board may need cutting to width.
10. Repeat on the other side of the roof .
11. Nail the angled roof edgings in the same way as step 8 (28mm buildings have square roof edgings)

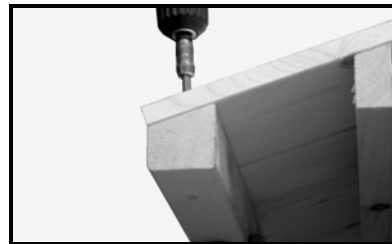

FIG 13

G - FELT ROOF-See tile pack or supplement for tiles

1. Several rolls of felt has been supplied.



FIG 14

2. Measure the length of the roof (fig 14) and add 200 mm to that length . This length is used to cut all the strips from the rolls of felt. (fig 15)



FIG 15

3. Use a piece of floorboard as a guide to cut the felt. (fig 16)
4. Measure up 952mm and mark at the front and back of each side of (and along) the roof.
5. Starting at the lower edge (eaves) on the building side place 1 piece of the felt from front to back of the building .
6. An overhang of approximately 100mm should be allowed at the front and the back (Fig 16).(all felt strips) and the length of the eaves edgings at the side
7. Line up the felt at the marks (step 4) leaving enough for overhang to cover the roof edging (fig 16) then Secure with felt nails at approximately 100mm spacing. But only a couple along the high edge at this time (nailed with overlap).



FIG 16

8. Overlap this strip with the next one next with a maximum of a 100mm overlap and nail as above and along the overlap.
9. Repeat on both sides until you get to the ridge piece.
10. The next piece will go over the high point of the roof and down both sides nail along the edges where it overlaps the other pieces of felt (fig 17) as before .
11. Sometimes the piece of felt either side of the roof will overlap the high point.



FIG 17



FIG 18

12. On the underside of the outside corners (fig 18) neatly cut, fold and secure using 1x felt nail.
13. Nail with felt nails at each roof bearer leaving space for fixing the fascias

H- FLOOR

1. Starting from the doors, position the first floorboard under the doorframe with the groove against the wall.(Floor must be under all doorframes) **Bevelled corner downwards to give flat floor**
2. Fix into position with 40mm oval nails. Continue with remaining floorboards.
3. Trim the last board to suit if necessary.

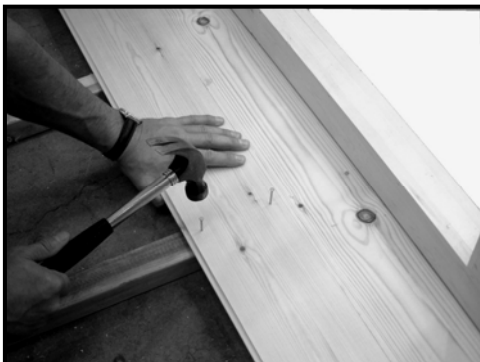

FIG 19

4. Cut the skirting boards to suit (**NOT UNDER DOOR FRAMES**) and fix with 40mm oval nails at approx 400mm centres (fig 20)



FIG 20

I- FASCIA & DIAMONDS

1. Fascia boards can now be drilled and screwed (fig 21) with 1x50mm screw at each roof bearer and the roof edgings.



FIG 21 example

2. Drill diamond and screw with 2x50mm screws .(fig 22)

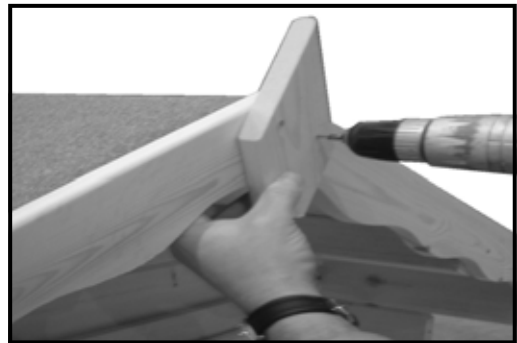

FIG 22 example

J- GLAZING

After painting

1. Place glazing material into the aperture of each window.
2. Hold into position with four pieces of beading. The beading may need to be swapped around to get the best fit. When satisfied secure into position using 2x 15mm panel pins per piece of beading (Fig 23).
3. Repeat for all window and door apertures.



FIG 23

28 mm BIG Double door assembly supplement

Parts list

Qty.	Description	Length	Code
2	Door frame 25x(log size) 28	1855	DA
2	Door frame 25x (log size) 28	1421	DB
4	Door architrave 70x20mm	1805	DC
2	Door architrave 90x20mm	1581	DD
2	Door architrave 70x20mm	1805	DE -external
2	Door architrave 70x20mm	1561	DF -internal
10	50mm screws		
50	40mm screws		
45	25mm screws		

Door frame

- 1 Refer to letter codes in above table.
- 2 Lay out the parts DA and DB as in fig 1. The 25mm edge to the work surface. Parts DB must be inside parts DA.
- 3 Screw together at each corner, 10mm in from the edge (ensuring each corner is flush) with 2x50mm screws (fig 2).

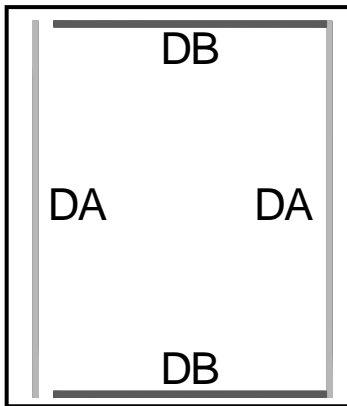

Fig 1

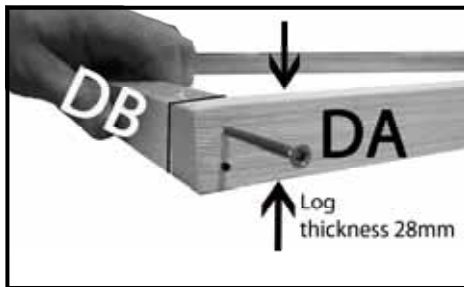

Fig 2

- 4 **REF.** This frame is set out the same as on the pre-constructed window frame.

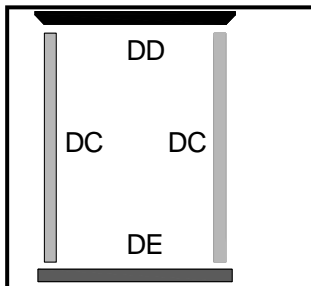

Fig 3

- 5 Layout parts DC, DD & DE (or DF internal door) as in fig 3.
- 6 Mark the first hole position 30mm from each end of part DC and then the rest at approximately 200mm centres.
- 7 **Note** the DC, DD & DE pieces fitted to the opposite side must be drilled offset to this side to ensure the screws miss each other.

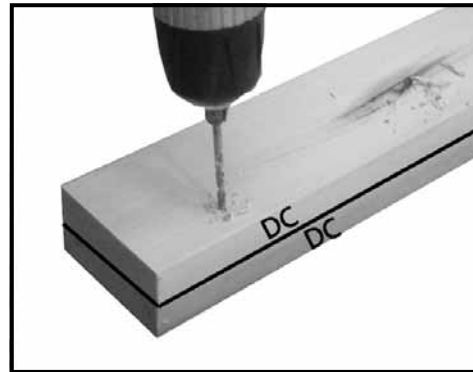

Fig 4

- 8 Place the other DC part underneath and drill through both pieces with a 3mm drill (fig 4)



Fig 5

- 9 Place one of the DC parts on top of the A parts level with the inside of the frame (fig 5).

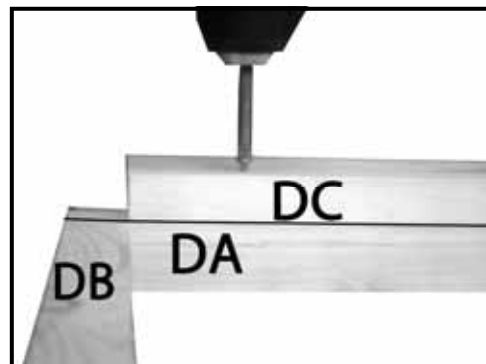

Fig 6

- 10 Fix to part DC to A with 40mm screws (fig 6 & 7) **important** fix at both ends first ensuring that they stay flush then the screws in between again ensuring that parts DA & DC are flush as you go.



Fig 7

- 11 Place a DD part on top of a DB part. the DD part is positioned so there is an even overhang (fig8). Mark out and drill fix as steps 8 to 10. **But** start at 100mm from the end of part DD.
- INTERNAL DOORS** have the DF pieces instead of the DE parts and finish flush with the bottom of the DB part underneath and square to the DC parts.
- THE FLOORBOARDS GO UNDER THE DOOR FRAME.**

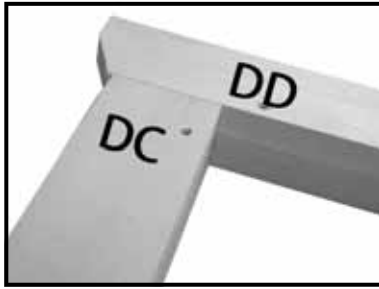

Fig 8

12 Drill (not too deep) and screw in each corner with 40mm screws (fig 9).



Fig 9

- 13 With a pencil mark the screw centres on the inside long edge of the frame to help ensure the door hinge screws will miss these screws.
 14 Turn frame over and repeat steps 5 to 13 on the other side (fig 10&11).
 15 **Note offset drilled holes from first side to ensure they miss each other first hole DC=40mm part DD =110mm**

Doors-MAY DE SOLID DOORS

Bradenham has piano hinges and black door knobs fit doors after frame in building

- 1 Lay doors on the floor, as you would view them from the inside of the building. Make sure the door with the lock is situated on the left when viewed from the bottom.
- 2 Lay the outer frame in position (fig 14).
- 3 The hinges are fitted on the longest outside edge of the doors.
- 4 Make a visual judgement to the gap top and bottom of the doors then transfer the screw centre marks (step A 13) to the doors. This is to ensure the hinge screws miss the frame screws.
- 5 Lift off the outer frame making note of which way around you have put it.
- 6 Place the hinges as shown in fig 12 & 13. Screw the inner piece of the hinge to the door with 2 x 25mm screws.

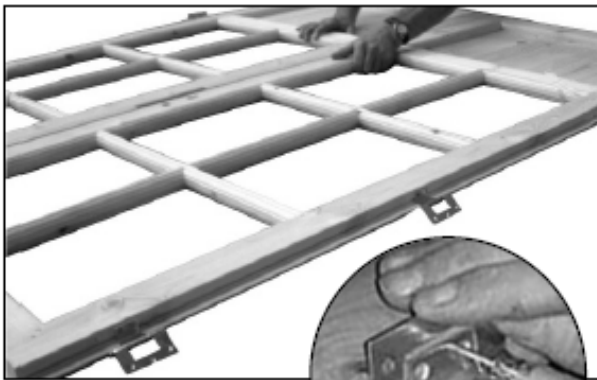

Fig 12

Fig 13

7 Close the hinges and lay the frame assembly over the doors (fig 14).

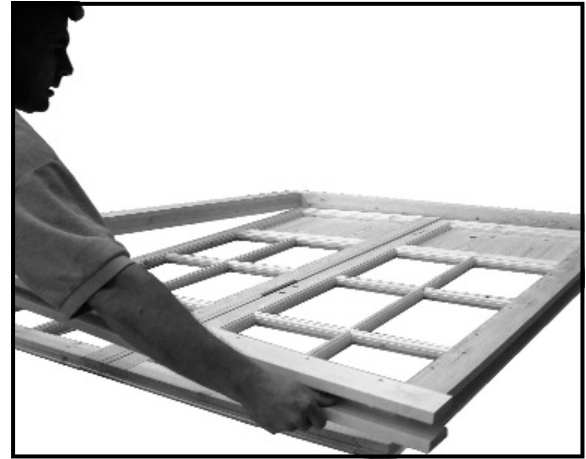

Fig 14

8 Make a visual judgement to set an even gap top/bottom of the doors and secure each hinge with 1x25mm screws (fig 15). **Ensure the hinges are tight against the face of the doorframe.**

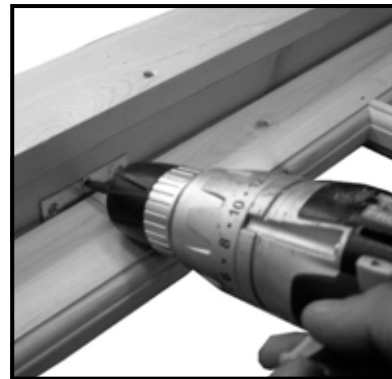

Fig 15

- 9 Stand the assembly up. **Note two people needed for this step.** Open the doors and secure hinges with remaining 4x25mm screws per hinge.
- 10 Lay the assembly down again with the doors facing down and Position the draught strips so the rubber is against the opening door and fix with 9x32mm oval nails for either side and 9x25mm oval nails each top and bottom (fig 16).
- 11 **Take note of where you are going to put the door bolts so there are no nails where you need to drill (step 12).**



Fig 16



Fig 17

- 12 Fit two bolts on the door without the lock (fig 17). The top bolt should be positioned just below the draught strip at the top of the door. Fix with 4x10mm screws.
- 13 Extend the bolt to meet the draught strip and mark then drill an 10mm hole through the draught strip (**not all the way through the frame**) to take the bolt.
- 14 Put the door assembly to one side until required.

SHIRE

BUILT AROUND OUR REPUTATION

34/44/70 DOUBLE DOOR -INNER FRAME ASSEMBLY

DOUBLE GLAZING
beading must be sealed
with low modulus
silicone sealant

SCREW
HERE
T

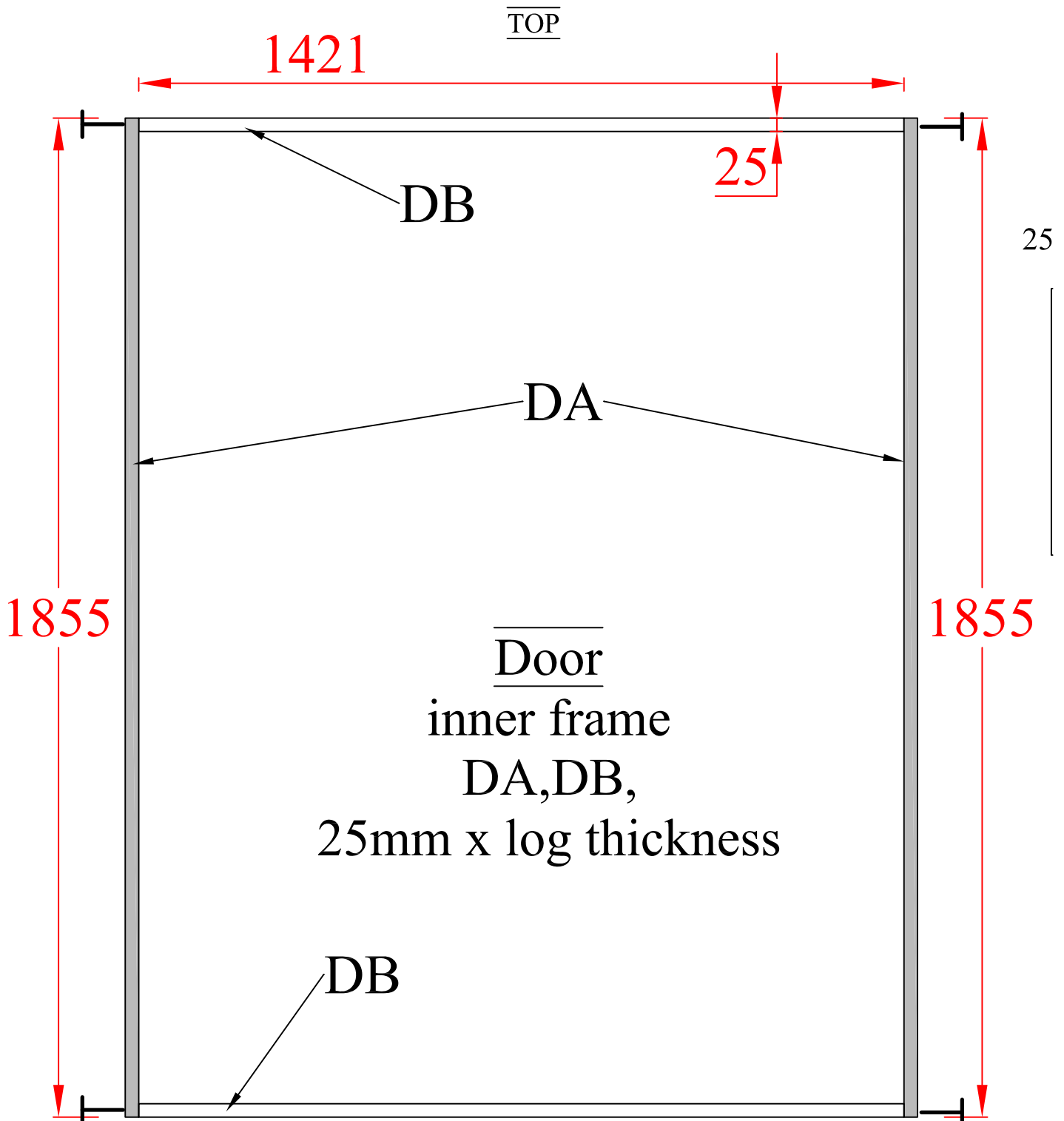

SHIRE

BUILT AROUND OUR REPUTATION

1777-2	1421-2	rubber
1600		drip bar

28/34/44/70DOUBLE DOOR OUTER FRAME ASSEMBLY

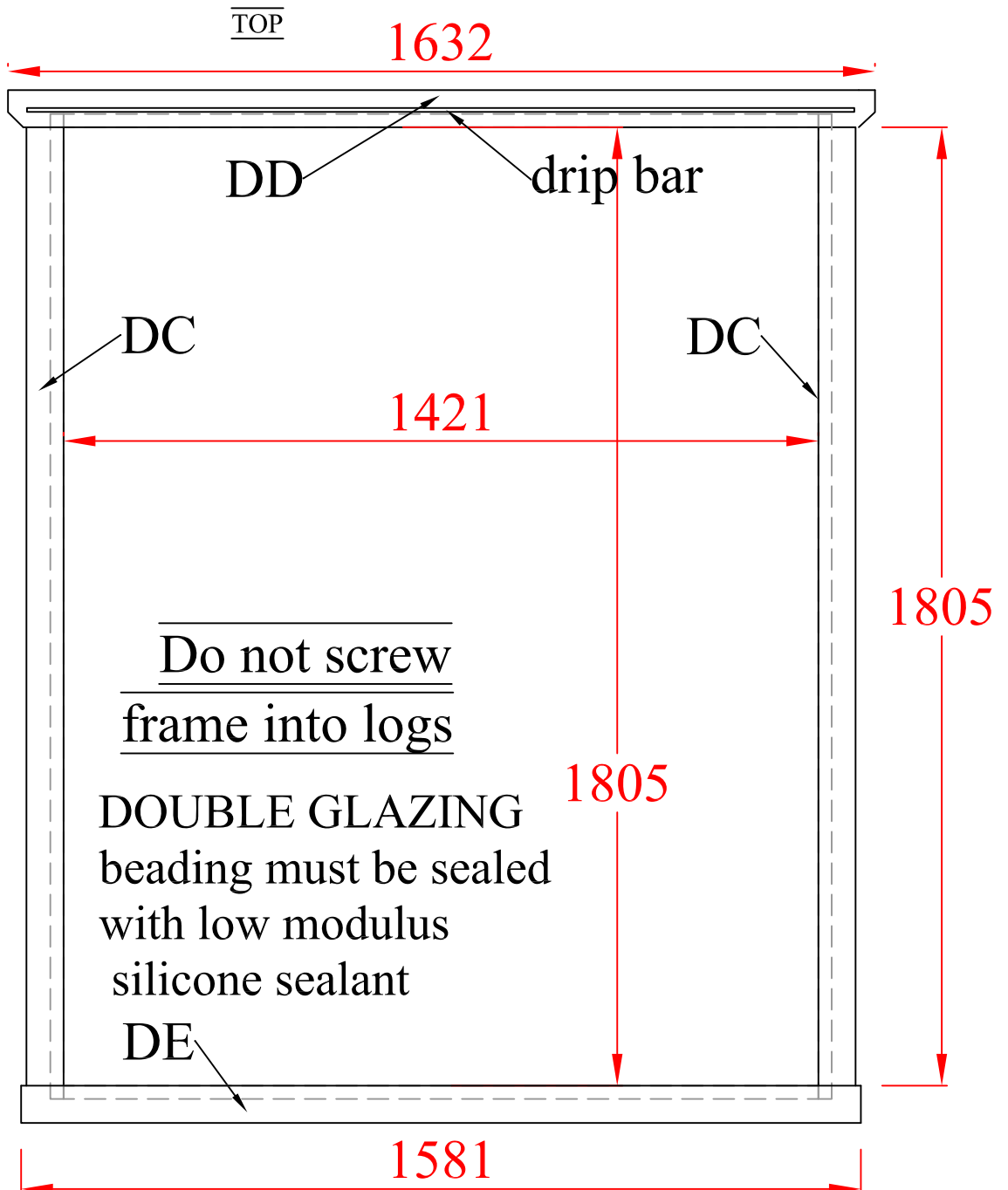

W9t Window assembly supplement

Parts list

YOU MUST READ THE SAFETY SUPPLEMENT AT THE BEGINNING OF THE MAIN INSTRUCTION SHEET

WINDOW KITS– Taped in sets

1	Windows	W9S –TOP HUNG	
2	Casement stays with 2 pins and screw sets		
2	Window hinges		
2	Window frame	25x29 x1196	W A
1	Window frame	25x29 x965	W B
1	Window frame	25x29x 915	W T
4	Window architrave	70x20x1276	W C
2	Window architrave	90x20x1125	W D
4	Window architrave	70x20x915	W E
1	Shaped drip bar	1090	
2	Draught excluder	1204	
2	Draught excluder	915	
30	Glazing	268 x 352	
60	Short Beading		
60	Long Beading		
4	100mm hinges		
52	40mm screws		
12	50mm screws		
28	25mm screws		
38	25mm oval head nails		
72	Panel pins		

A Window Frame

1. Refer to the window drawing page and to letter codes in contents table. The **WT** and **WD** parts will be at the top of the window frame. **Do not tighten the inside of the frames so you can remove for treatment.**
2. To be sure you can lay all the pieces, including inserts together without fixing to familiarise yourself with the assembly.
3. Make sure the window insert fits inside the frame with a 5mm gap all around.
4. Lay out the parts **WA** and **WB** and **WT** as in the inner frame assembly drawing. The narrowest (25mm) edge to the work bench and the side the size is the same as the log thickness as shown in fig A1. Part **WT** must be inside parts
5. **WA** and part **WB** underneath the two **WA** parts (Fig A1).
6. Pre drill 2 3mm holes at one end of the **WA** only and at both ends of the **WB** parts (see drawing)and screw together at each corner, 10mm from the edge (ensuring each corner is flush) with 2x50mm screw (fig A1).

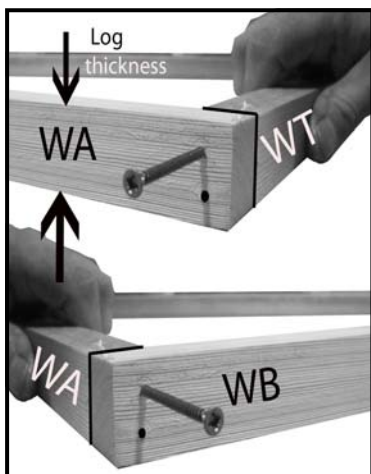

Fig A1

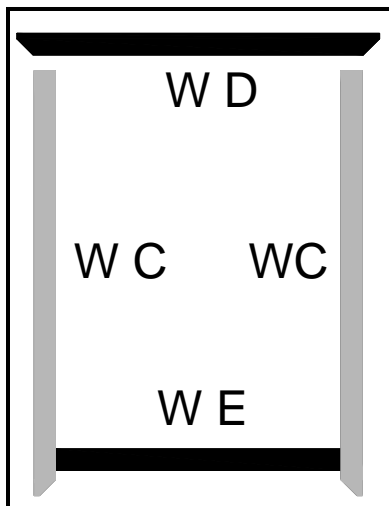

Fig A2

7. Layout parts **WC**, **WD** & **WE** as in fig A2 & drawing on top of the frame from steps 1-6 flush with the inner edge of the frame.

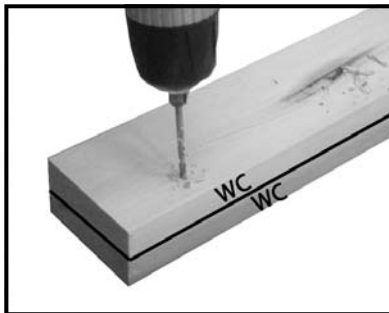

Fig A3

8. Mark the first hole position 30mm from the end of part **WC** that is next to part **WD**, at the other end mark the hole central to the **WB** underneath and then the rest at approximately 260mm centres between these holes.
9. Note the **WC**, **WD** & **WE** pieces fitted to the opposite side must be drilled offset to this side to ensure the screws miss each other.
10. Place the other **WC** part underneath and drill through both pieces with a 3mm drill (fig A3).

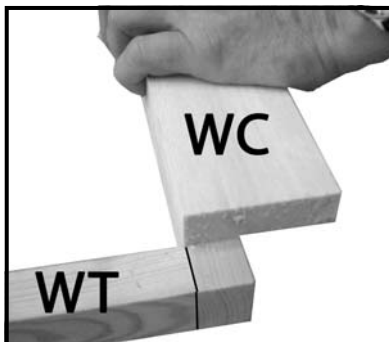

Fig A4

11. Place one of the **WC** parts on top of the **WA** parts level with the inside of the frame and the bottom of the **WT** part (fig A4).
12. Fix to part **WC** to **WA** with 40mm screws (fig A5 & A6)
13. **important** fix at both ends first ensuring that they stay flush then the screws in between again ensuring that parts **WA** & **WC** are flush as you go

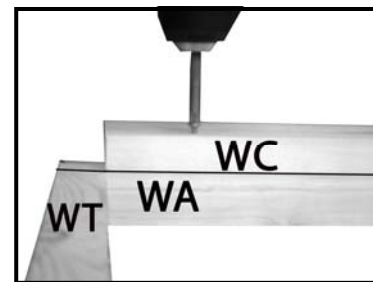

Fig A5

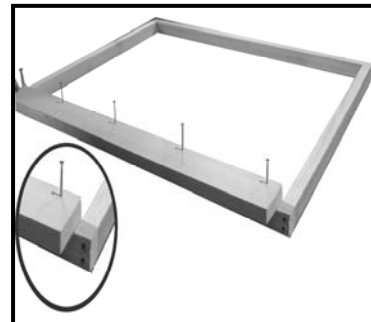

Fig A6

14. Place a **WD** part on top of a **WB** part. The **WD** part is positioned so there is an even overhang (fig A7). Mark out and drill fix as steps 8 to 10. But start at 100mm from the end of part **WD**.

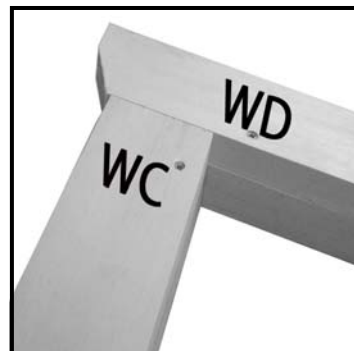

Fig A7

15. Drill (not too deep) and screw in each corner with 40mm screws (fig A8).

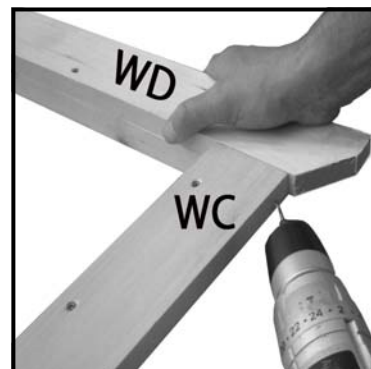

Fig A8

16. With a pencil mark the screw centres on the inside long edge of the frame to help ensure the hinge screws will miss these screws.
17. Turn frame over and repeat steps 4 to 12 on the other side (fig A9 & A10).
18. **Note offset drilled holes from first side to ensure they miss each other first hole part WC =30mm part WD =100mm**

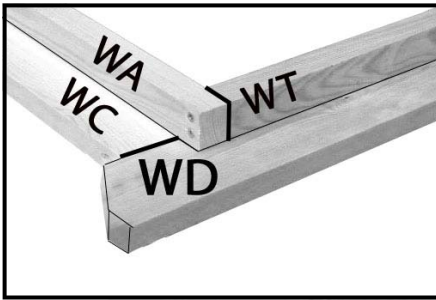

Fig A9

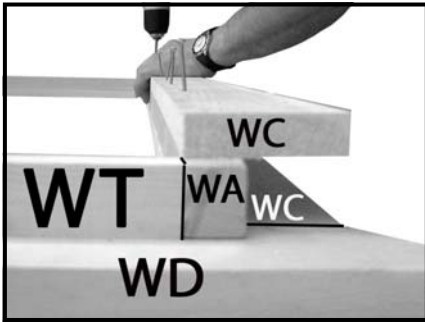

Fig A10

19. **Window insert.** Place one hinge on the inner rebate part of the window; approx. One hinge width along from the rebate edge **on the top side**. The rounded part of the hinge should sit above the outer edge of the window. Screw the inner piece into position
20. (fig. A11 &A12) using the pre drilled holes in the hinge and 3 x 25mm screws. Repeat with the other hinge. And close the hinges together.

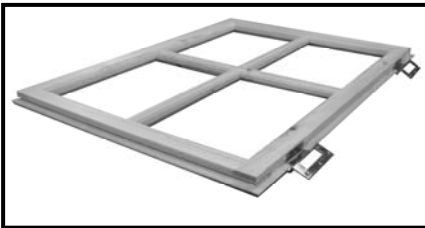

Fig A11– STYLE MAY VARY

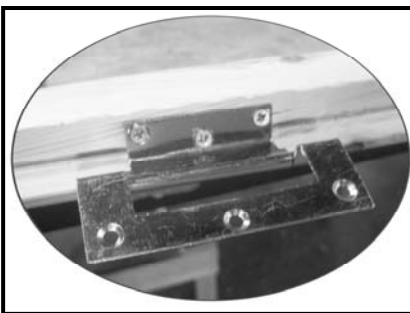

Fig A12

22. Place the window into the aperture (fig A13) **ensure that part WD** (FIG A13) is against the hinges (TOP HUNG)**or** against the **WC** (side hung) .
23. Secure the window to the panel using 3x 25mm screws per hinge, (fig. A14) again through the predrilled holes in the hinge.
24. Repeat.

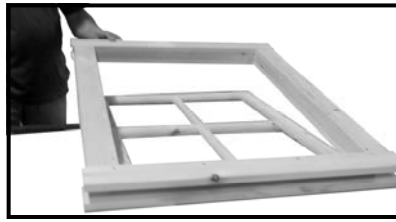

Fig A13

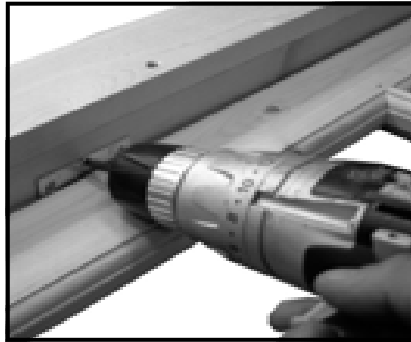

Fig A14

24. Open the window fully in order to fit a further 2x 25mm screws per hinge (Fig.A15).

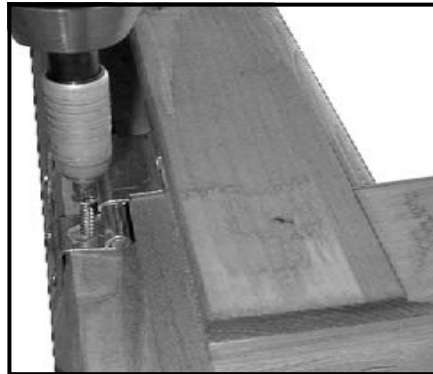

Fig A15

25. Fitting the draught excluder.
This must be done before fitting the casement stays.



Fig A16

26. Lay the assembled window unit with the opening insert downwards onto your work surface (Fig A16).
27. Position the draught strips so the rubber is against the opening insert and fix with 4x25mm oval nails per strip (Fig A16).
28. **Fitting the Casement Stays.** There are two per window. Place the casement stays evenly on the inside of the window (Fig A17) on top of the draught excluder.

29. Place the 2 pins under each casement stay. Position so that it is not resting on the window frame and not so high that the pins are of no use.

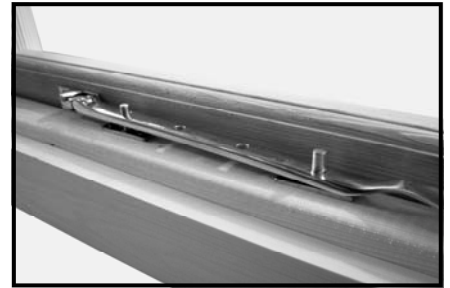

Fig A17

30. Fit the Casement Stay (fig A18) on the window using 2x 25mm screws.

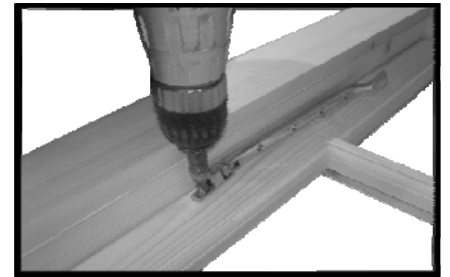

Fig A18

31. Mark where the 'pins' will be placed.

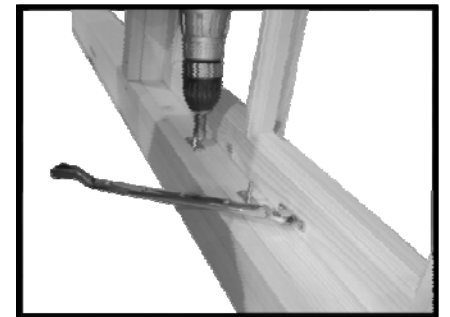

Fig A19

32. Secure into position using 4x 25mm screws - 2 in each pin.
33. **Drip bar.** Turn the window unit over so the opening insert is uppermost .



Fig A20

34. Position the drip bar the drip bar by measuring 45mm down from the top of the **WD** part above the hinges and fix the drip bar with 3x25mm screws. Repeat with the other window unit
35. Put the completed units to one side until required .
36. **Note** do not glaze until all parts have been treated and the units fitted in the building

W9S
WINDOW
-INNER FRAME
ASSEMBLY

Window
inner frame
WA, WB, WT
25xlog thickness

TOP

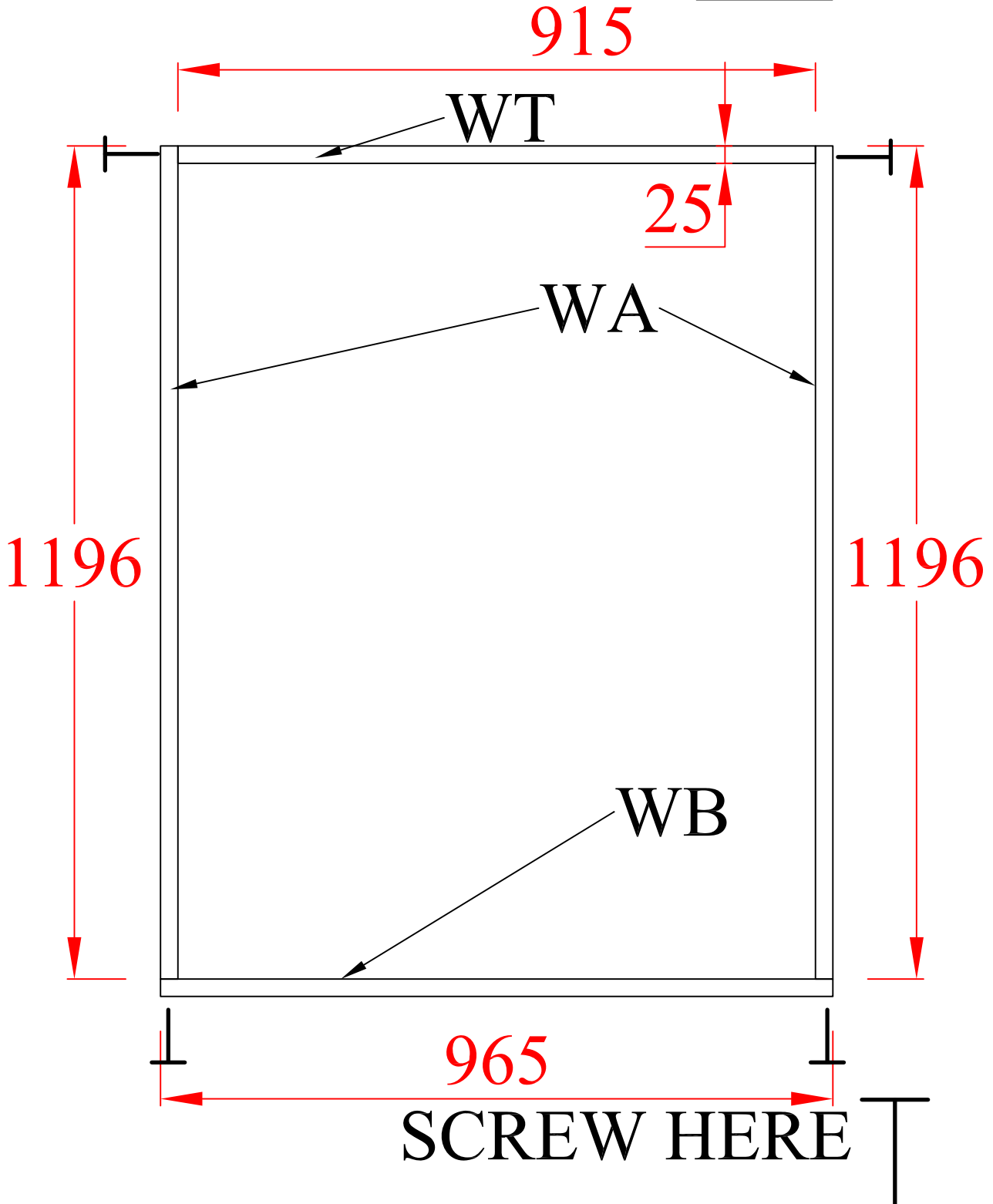

SHIRE

BUILT AROUND OUR REPUTATION

TOP

915-2	1204-2	rubber
1090		drip bar

WINDOW- OUTER FRAME ASSEMBLY

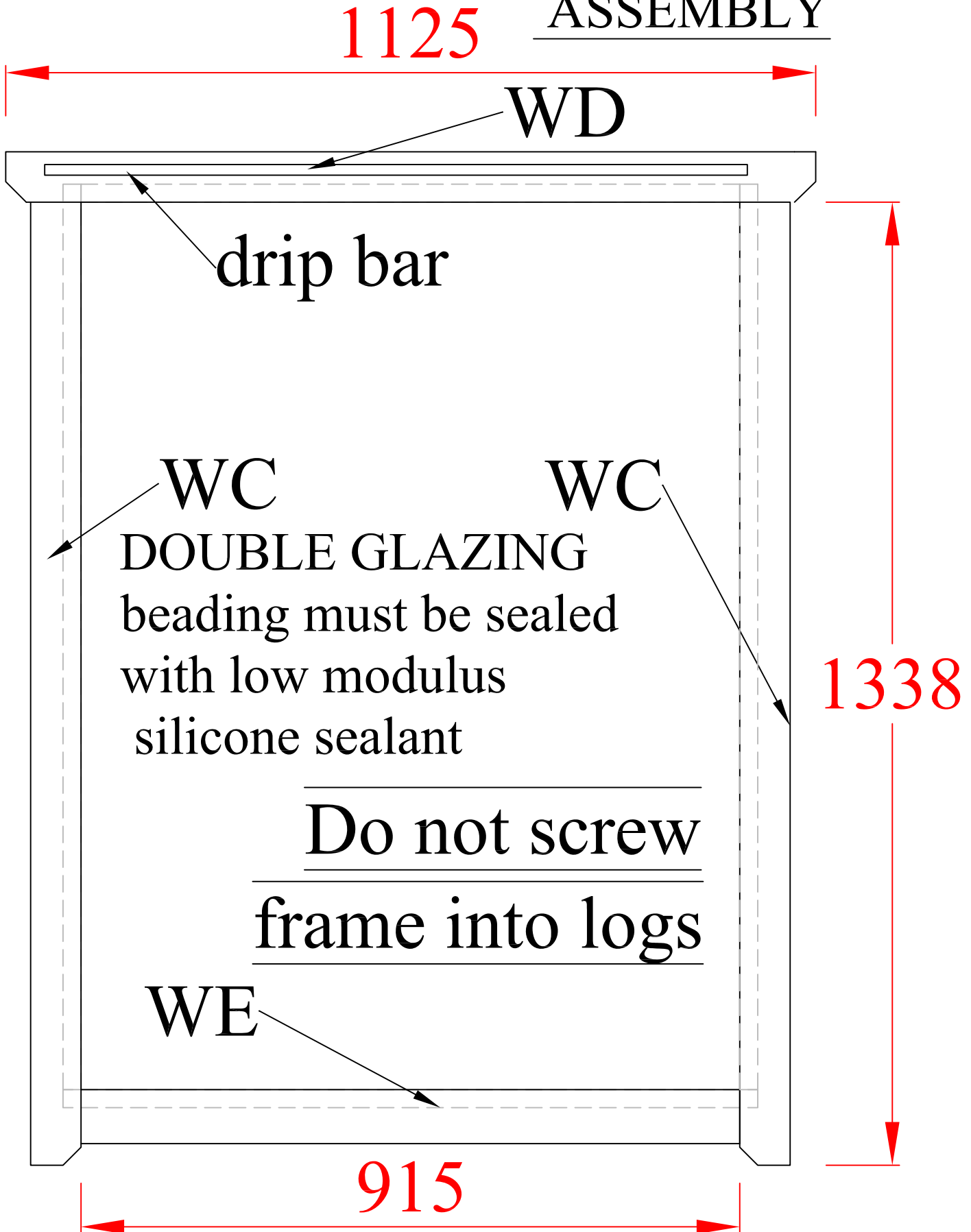

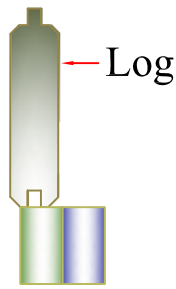

Fig 2
Detail of log sitting on floor joists running parallel to floor bearers

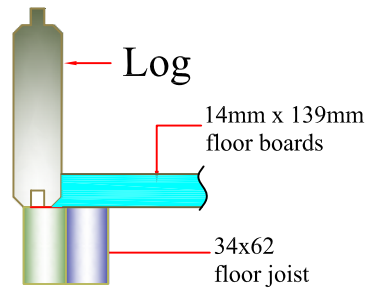

Fig 3
Detail showing floorboard on joist

4190x3590g(14X12g)
Ringwood 2.5 Ridge
28mm log
FLOOR PLAN

Pressure treated
Floor joists 38x63
16 x 2148 & 6 joiners
4 x 2428

Floor boards
19 x 3340
15 x 2290

DECK

Pressure treated
joists 38x63 5x1050
Deck boards
8 x 1866
1x50x1866

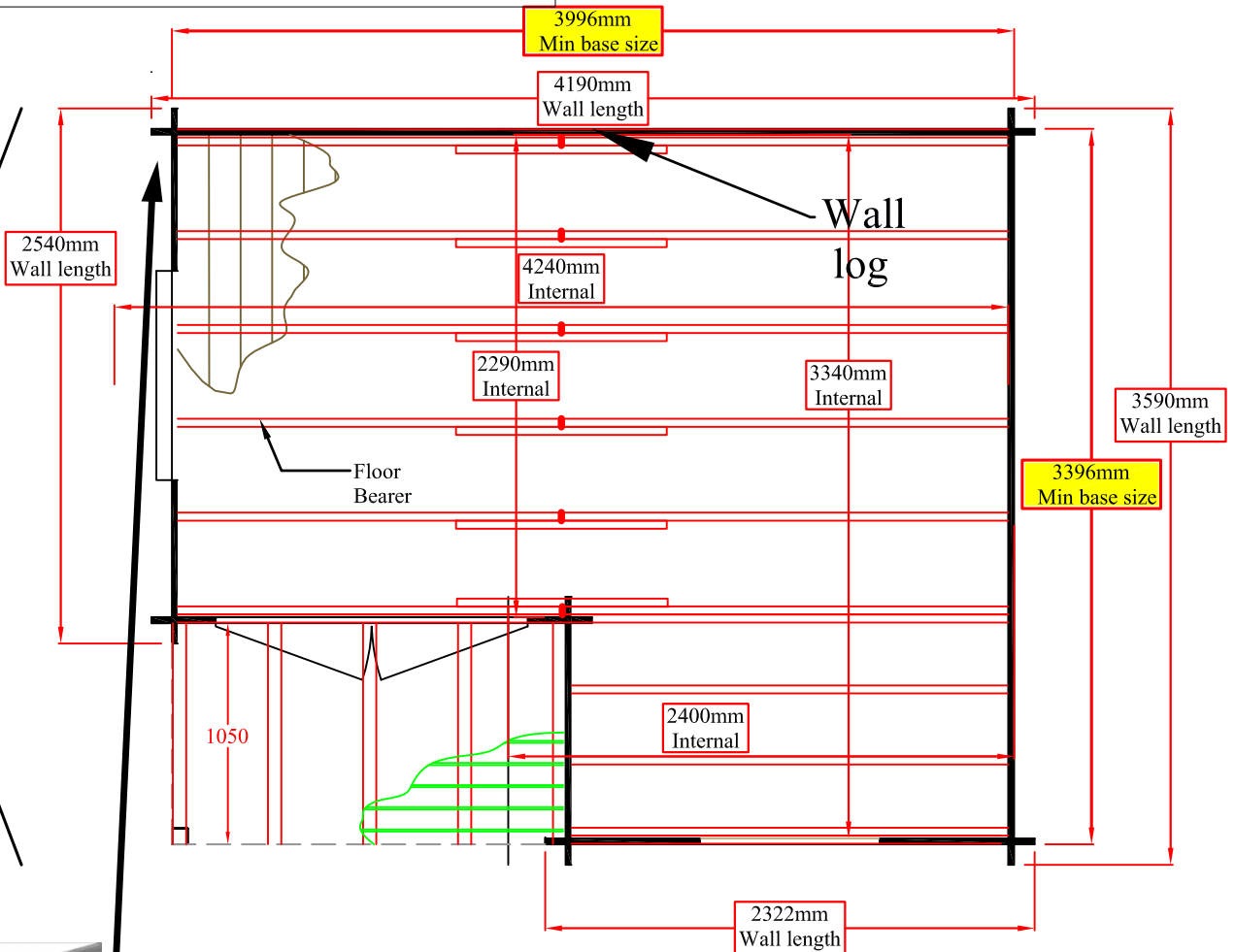
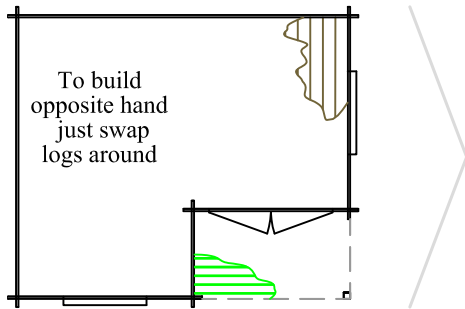

Base details & Floor bearer layout

see page 2,3&4 for spacing

LH side view

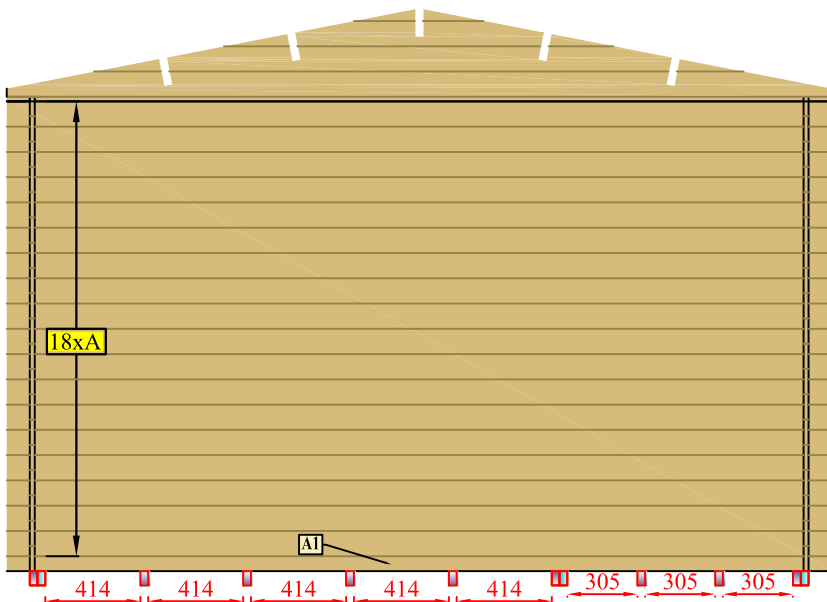
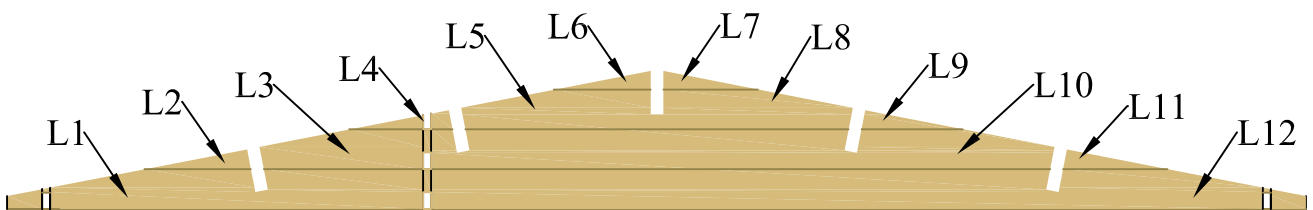
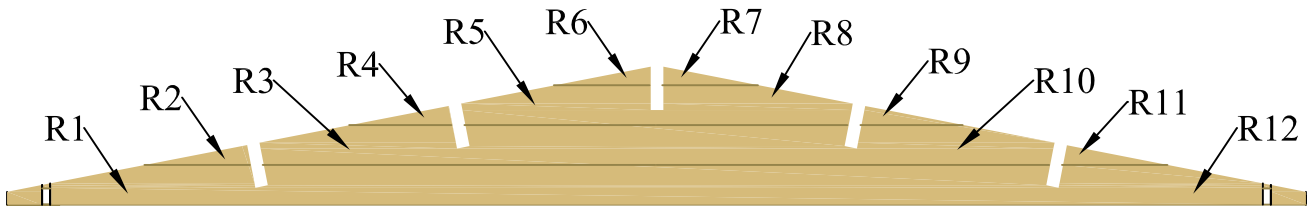
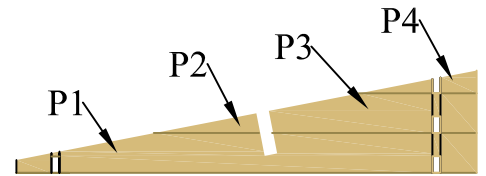

4190x3590g(14X12g)
Ringwood 2.5 Ridge
BIG JOINERY
28mm log
LH END
Parts list
A x 18
A1 x 1

3468
bearer spacing

To build opposite hand just swap logs around

2022

page 3

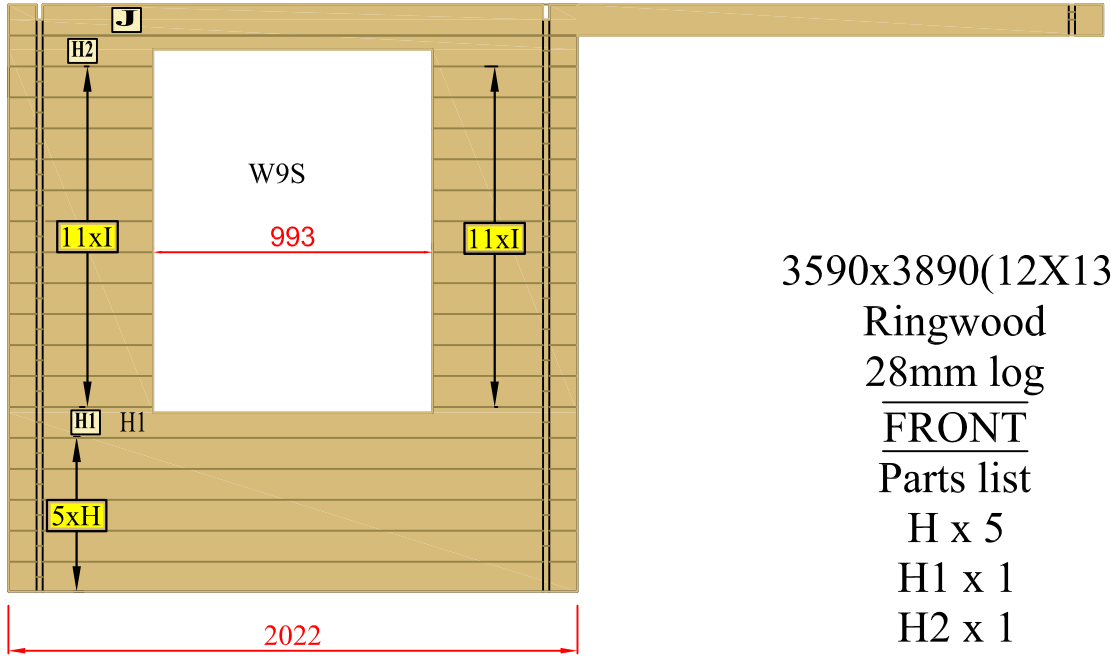

3590x3890(12X13)

Ringwood
28mm log

FRONT

Parts list

H x 5

H1 x 1

H2 x 1

I x 22

Jx1

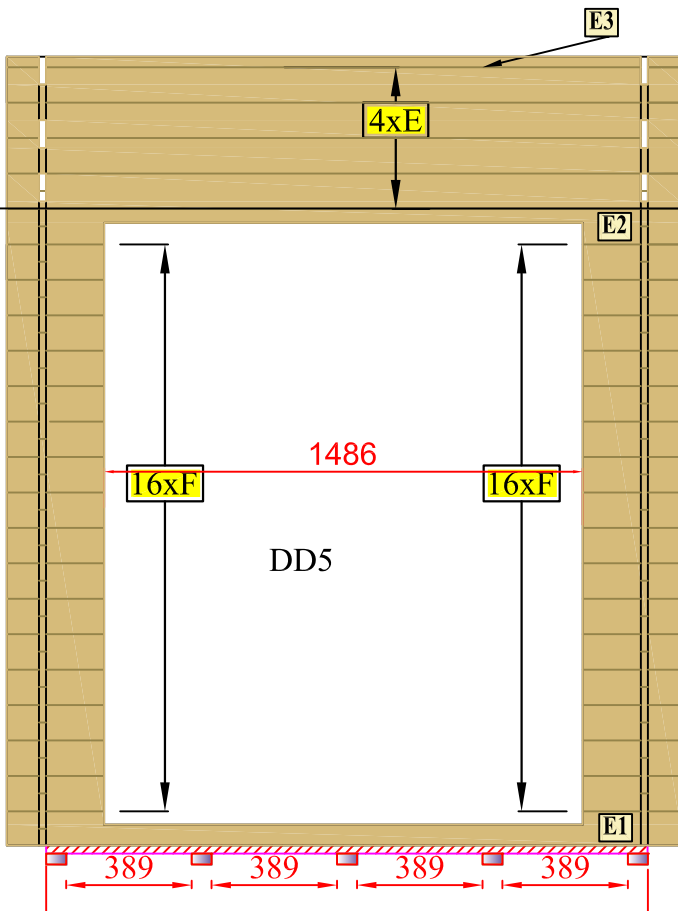

3590x3890(12X13)

Ringwood
28mm log

DOOR PANEL

Parts list

E x 4

E1 x 1

E2 x 1

E3 x 1

F x 32

bearer spacing

Deck fits in front of panel
not underneath

To build opposite hand just swap logs around

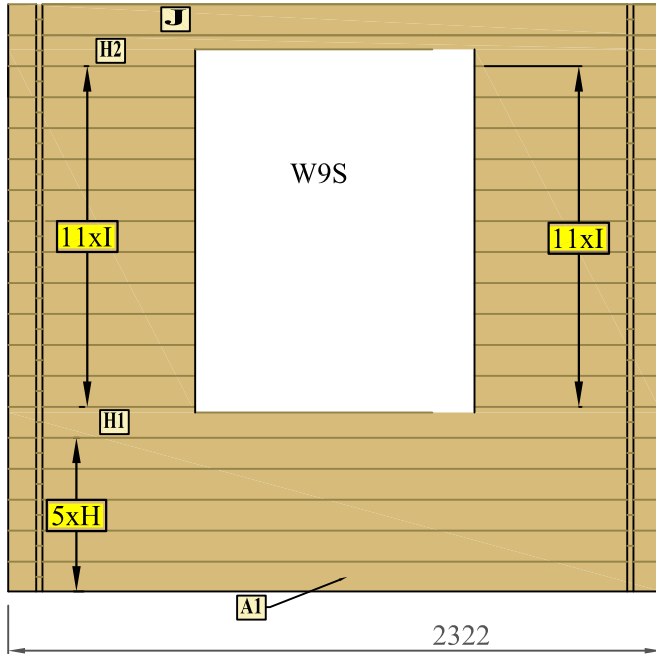
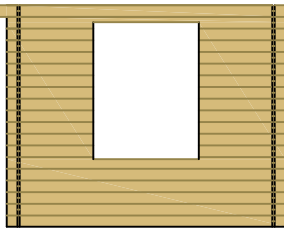

4190x3590g(14X12g)
Ringwood 2.5 Ridge
BIG JOINERY

28mm log

FRONT

Parts list

H x 5

H1 x 1

H2 x 1

I x 22

Jx1

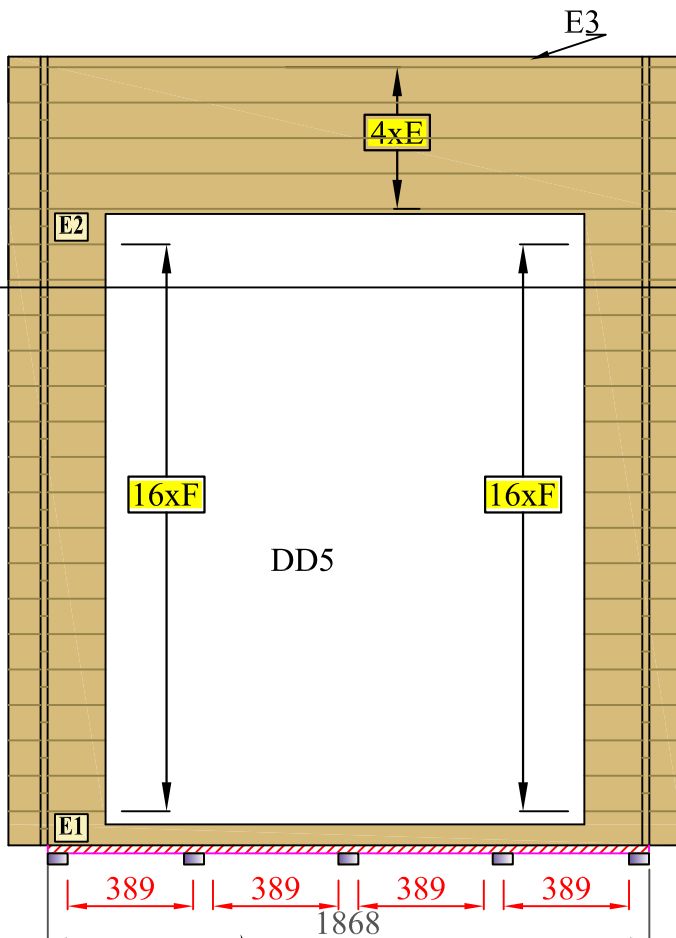

4190x3590g(14X12g)
Ringwood 2.5 Ridge
BIG JOINERY

28mm log

DOOR PANEL

Parts list

E x 4

E1 x 1

E2 x 1

E3 x 1

F x 32

Deck fits in front of panel
not underneath

bearer spacing

4190x3590g(14X12g)
Ringwood 2.5 Ridge
BIG JOINERY

28mm log

RH END

Parts list

C x 6

C1 x 1

C2 x 1

D x 22

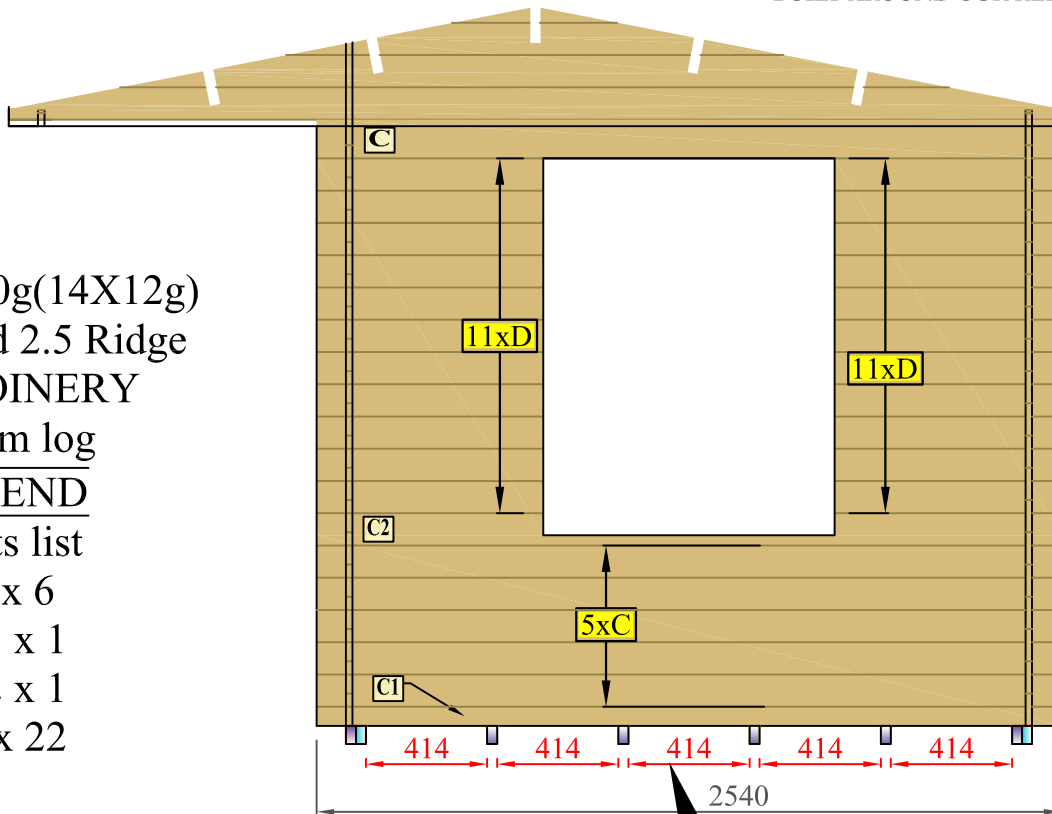

bearer spacing

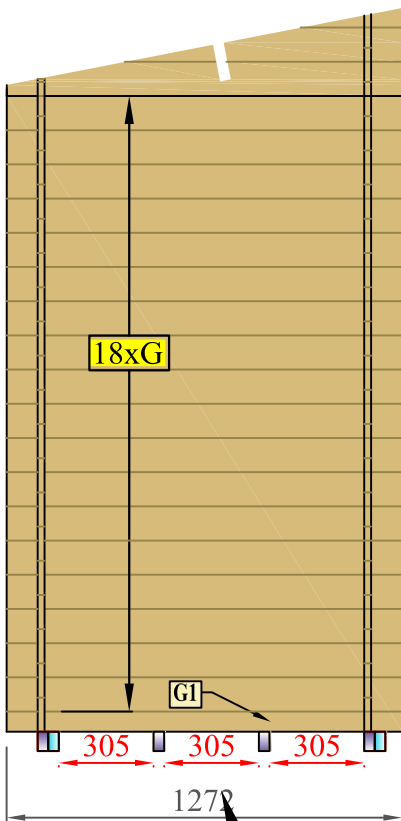

bearer spacing

4190x3590g(14X12g)
Ringwood 2.5 Ridge
BIG JOINERY

28mm log

SM RH END

Parts list

G x 18

G1 x 1

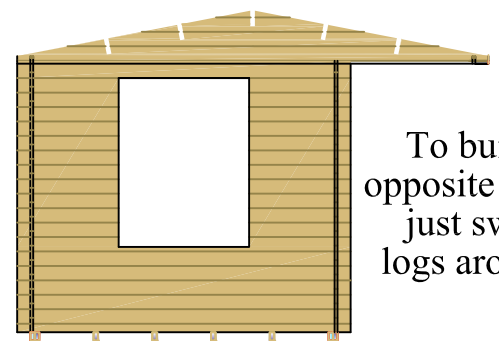

To build
opposite hand
just swap
logs around

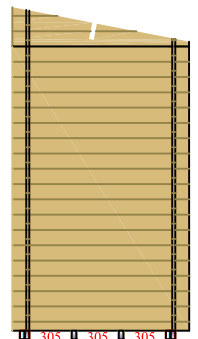

4190x3590g(14X12g)

Ringwood 2.5 Ridge

BIG JOINERY

28mm log

BACK

Parts list

B x 19

SHIRE

BUILT AROUND OUR REPUTATION

page 5

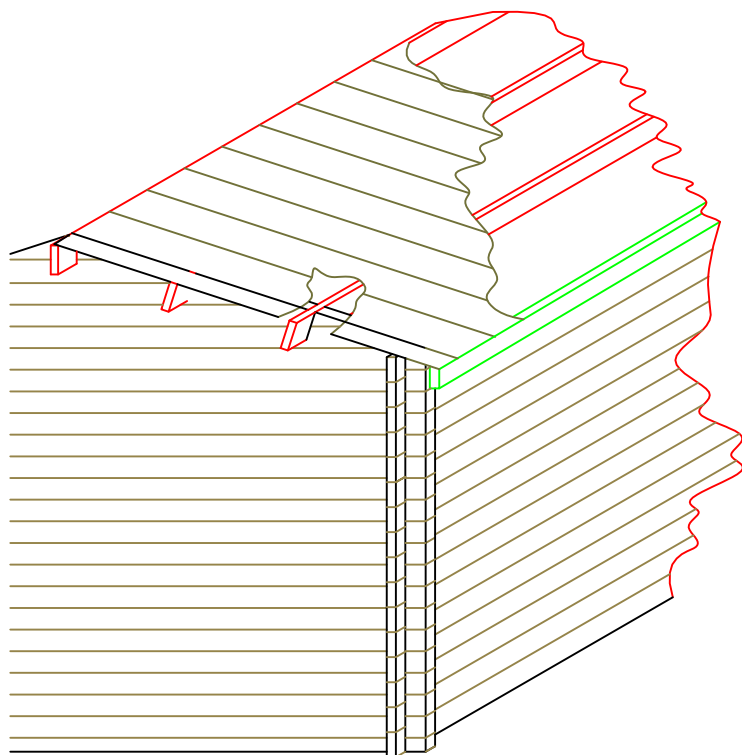
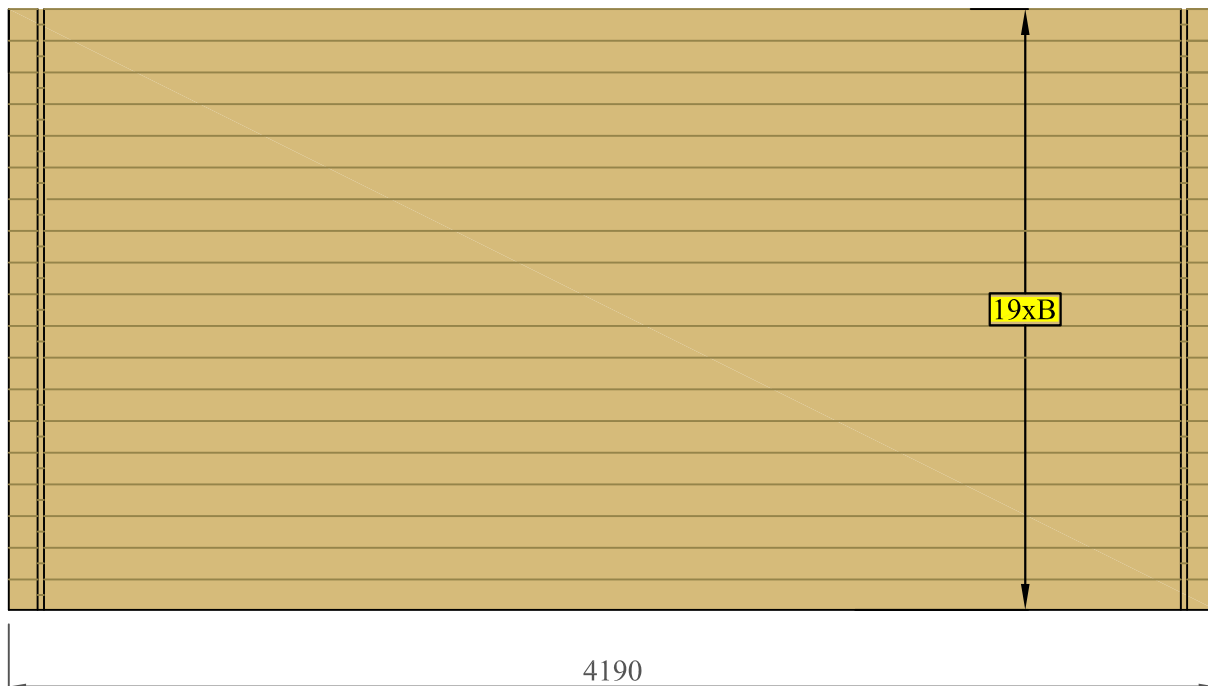

4190x3590g(14X12g)

Ringwood 2.5 Ridge

28mm log

ROOF ASSY

Parts list

5 Roof bearers

2 Angled eaves
edging strips

2 Roof edgings

66 Roof boards

2000 Long

Roof Materials