

TRANSLATION OF THE ORIGINAL INSTRUCTIONS (ISTRUZIONI ORIGINALI)

INTRODUCTION

Dear Customer,

Thank you for having chosen one of our products. We hope that you will get complete satisfaction from using your new machine and that it will fully meet all your expectations.

This manual has been written to help you become familiar with the machine and use it safely and efficiently. Do not forget that it is an integral part of the machine, so keep it close at hand for future reference and pass it on to the purchaser if you sell the machine.

This new lawn tractor has been designed and built in compliance with current standards, and is safe and reliable if used for cutting and collecting grass following the instructions given in this manual (**proper usage**). If you use the machine in any other way or ignore the instructions for safe use, maintenance and repair, it is considered "**incorrect usage**" (👁 5.1). In this case, the warranty is automatically voided and the Manufacturer is not held responsible for damage or injury to oneself or others.

Since we regular improve our products, you may find slight differences between your machine and the descriptions contained in this manual. Modifications can be made to the machine without notice and without the obligation to update the manual, al-

though the essential safety and function characteristics will remain unaltered. If in doubt, do not hesitate to contact your dealer. And now enjoy your work!

AFTER-SALES SERVICE

This manual gives all the necessary instructions for using the machine and carrying out basic maintenance.

Any adjustments or maintenance operations not described in this manual must be carried out by your Dealer or a specialized Service Centre. Both have the necessary knowledge and equipment to ensure that the work is done correctly without affecting the safety of the machine.

If you wish, you can ask your dealer to prepare a maintenance programme personalised to your needs. This will help you keep your new purchase in peak performance and maintain its value over time.

TABLE OF CONTENTS

1. SAFETY	3
Regulations for using the machine safely	
2. IDENTIFICATION OF THE MACHINE AND COMPONENTS	7
How to identify the machine and its main components	
3. UNPACKING AND ASSEMBLY	9
How to remove the packing and assemble loose parts	
4. CONTROLS AND INSTRUMENTS	13
Position and functions of all the controls	
5. HOW TO USE THE MACHINE	17
Instructions for working efficiently and safely	
5.1 Safety recommendations	17
5.2 Why the safety devices cut in	17
5.3 Preliminary operations before starting work	18
5.4 Using the machine	20
5.5 Using on slopes	25
5.6 Transporting the machine	26
5.7 Lawn maintenance	26
6. MAINTENANCE	27
All the information for maintaining the machine in peak efficiency	
6.1 Safety recommendations	27
6.2 Routine maintenance	27
6.3 Interventions on the machine	29
7. ENVIRONMENTAL PROTECTION	32
It gives advice on machine use and respecting the environment	
8. TROUBLESHOOTING	33
A help in quickly solving problems	
9. ACCESSORIES ON REQUEST	35
A description of the accessories available for special requirements	
10. SUPPLEMENTARY EQUIPMENT	36
List of equipment that can be installed on the machine to extend use possibilities	
11. SPECIFICATIONS	37
A summary of the main specifications of your machine	

1. SAFETY

1.1 HOW TO READ THE MANUAL

Some paragraphs in the manual containing important information regarding safety and operation are emphasized in the following ways:

NOTE

or

IMPORTANT

These give details or further information on what has already been said, in the aim to prevent damage to the machine.

⚠ WARNING!

Non-observance will result in the risk of injury to oneself or others.

⚠ DANGER!

Non-observance will result in the risk of serious injury or death to oneself or others

This manual describes various versions of the machine, which mainly differ as follows:

- type of transmission: with either mechanical gear change or hydrostatic continuous speed adjustment. The models with hydrostatic transmission are identified by the word "HYDRO" on the identification label (☞ 2.1);
- the inclusion of components or accessories which are not widely available;
- special equipment fitted.

The symbol "☞" highlights all the differences in usage and is followed by the indication of the version to which it refers.

The symbol "☞" refers to another part of the manual where further information can be found.

NOTE

Positions on the machine, such as "front", "back", "left" or "right" hand side, refer to the direction of forward travel.

IMPORTANT

For all operations regarding the use and maintenance of the engine or the battery not described in this manual, refer to the relevant manuals which form an integral part of all the documentation supplied with the machine.

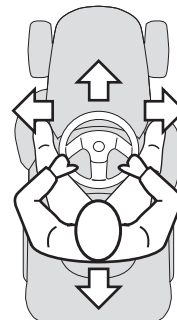

1.2 GENERAL SAFETY REGULATIONS

⚠ WARNING!

Read carefully before using the machine.

A) TRAINING

- 1) **Read the instructions carefully.** Be familiar with the controls and how to use the equipment properly.
- 2) Never let children or people unfamiliar with these instructions use the machine. Local regulations can restrict the age of the user.

3) **Never mow while people, especially children, or pets are nearby.**

- 4) Keep in mind that the operator or user is responsible for accidents or hazards occurring to other people or their property.
- 5) Do not carry passengers.
- 6) All drivers should seek and obtain professional and practical instruction. Such instruction should emphasise:
- the need for care and concentration when working with ride-on machines;
 - you cannot use the brake to regain control of a ride-on machine sliding down a slope. The main reasons for loss of control are:
 - insufficient wheel grip;
 - overspeeding;
 - inadequate braking;
 - the type of machine is unsuitable for its task;
 - unawareness of the effect of ground conditions, especially slopes;
 - incorrect hitching and load distribution.

B) PREPARATION

1) **While mowing, always wear sturdy footwear and long trousers.** Do not operate the equipment barefoot or wearing open sandals.

2) Thoroughly inspect the area where the equipment is to be used and remove all objects which can be ejected from the machine.

3) **DANGER! Petrol is highly flammable:**

- store fuel in containers specifically designed for this purpose;
- refuel outdoors only and do not smoke while refuelling;
- **add fuel before starting the engine. Never remove the cap of the fuel tank or add petrol while the engine is running or when the engine is hot;**
- if you spill petrol, do not start the engine and move the ma-

chine away from the area of spillage. Do not create any source of ignition until the petrol vapours have evaporated;

- put back and tighten all fuel tank and container caps securely.
- 4) Replace faulty silencers.
- 5) **Before use**, always inspect the machine to check that the blades, blade bolts and cutter assembly are not worn or damaged. Replace worn or damaged blades and bolts in sets to preserve balance.
- 6) On multi-bladed machines, remember that the rotation of one blade can cause other blades to rotate.

C) OPERATION

1) Do not start the engine in a confined space where dangerous carbon monoxide fumes can collect.

2) Mow only in daylight or good artificial light.

3) Before starting the engine, disengage the blades and shift into neutral.

4) **Do not use on slopes of more than 10° (17%).**

5) **Remember there is no such thing as a “safe” slope.**

Travelling on grass slopes requires particular care. To guard against overturning:

- do not stop or start suddenly when going up or downhill;
 - engage the drive slowly and always keep the machine in gear, especially when travelling downhill;
 - machine speeds should be kept low on slopes and during tight turns;
 - **tay alert for humps and hollows and other hidden hazards;**
 - **never mow across the face of the slope.**
- 6) Use care when pulling loads or using heavy equipment:
- use only approved drawbar hitch points;
 - limit loads to those you can safely control;
 - do not turn sharply. Use care when reversing;
 - use counterweight(s) or wheel weights whenever advised in the instructions manual.

7) Disengage the blades before crossing surfaces other than grass.

8) **Never use the machine with damaged guards, or without the safety protective devices in place.**

9) **Do not change the engine governor settings or overspeed the engine.** Operating the engine at excessive speed can increase the risk of personal injury.

10) Before leaving the driving seat:

- disengage the blades and lower the attachments;
- go into neutral and apply the parking brake;
- stop the engine and remove the ignition key.

11) **Disengage the blades, stop the engine and remove the ignition key:**

- before clearing blockages or unclogging the collector channel;
- before cleaning, checking or servicing the machine;
- after striking a foreign object. Inspect the machine for damage and make repairs before restarting and operating the machine;
- If the machine starts to vibrate abnormally (check for the causes immediately).

12) Disengage the blades for transport or whenever they are not in use.

13) **Stop the engine and disengage the blades:**

- before refuelling;
- before removing the grass-catcher.

14) Reduce the throttle during engine run-out. If the engine is provided with a shut-off valve, cut off the fuel when you have finished mowing.

3) Allow the engine to cool before storing in any enclosure.

4) To reduce fire hazards, keep the engine, silencer, battery compartment and petrol storage area free of grass, leaves, or excessive grease.

5) Check the grass-catcher frequently for wear or deterioration.

6) **Replace worn or damaged parts for safety purposes.**

7) If the fuel tank has to be drained, this should be done outdoors.

8) On multi-bladed machines, remember that the rotation of one blade can cause other blades to rotate.

9) When the machine is to be stored or left unattended, lower the cutting deck.

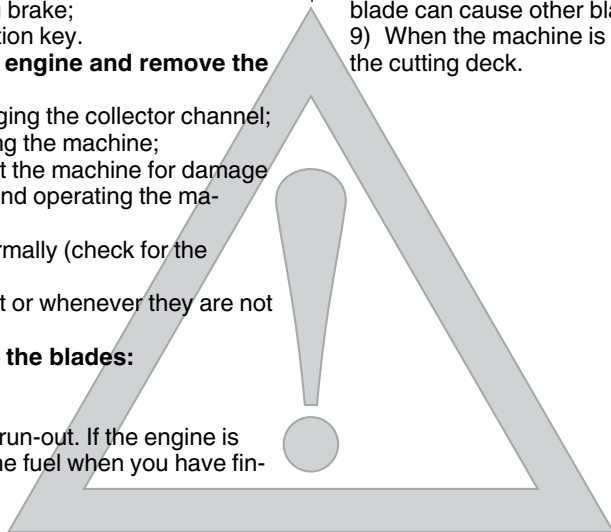

D) MAINTENANCE AND STORAGE

1) Keep all nuts, bolts and screws tight to be sure the equipment is in safe working condition.

2) Never store the equipment with petrol in the tank inside a building where fumes may reach an open flame or spark.

1.3 SAFETY LABELS

Your machine must be used with care. This is why labels with illustrations have been placed on the machine, to remind you of the main precautions to take during use.

These labels are to be considered an integral part of the machine.

Should a label come off or become illegible, contact your dealer to replace it. Their meaning is explained below.

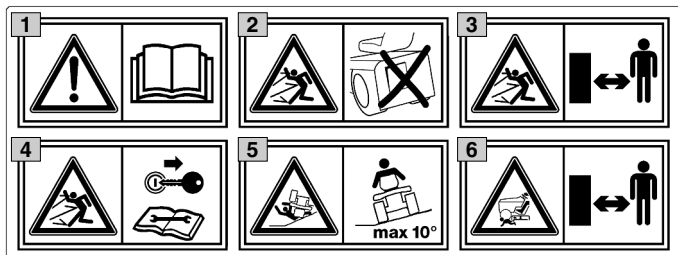

- 1** **Warning:** Read the instructions before operating this machine.
- 2** **Danger! Ejected objects:** Do not operate without the stone-guard or grass-catcher in place.
- 3** **Danger! Ejected objects:** Keep bystanders away.
- 4** **Warning:** Disconnect the ignition key and read the instructions before carrying out any repair or maintenance work.
- 5** **Danger! Machine rollover:** Do not use this machine on slopes steeper than 10°.
- 6** **Danger! Dismemberment:** Make sure that children stay clear of the machine at all time when engine is running.

- 7** **Danger of cutting yourself.** Blades in movement. Do not put hands or feet near or under the opening of the cutting plate.



- 8** **Warning!** Keep away from hot surfaces.

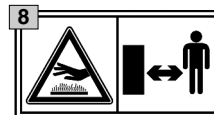

1.4 REGULATIONS FOR TOWING

A kit for towing a small trailer is available on request. This accessory is to be fitted following the instructions provided.

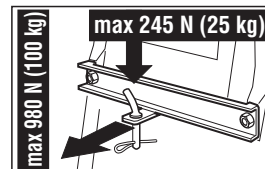

When using the towing kit, do not exceed the recommended loads stated on the label and follow the safety instructions (☛ 1.2, C-6).

2. IDENTIFICATION OF THE MACHINE AND COMPONENTS

2.1 IDENTIFICATION OF THE MACHINE

The label located near the battery housing has the essential data of each machine.

1. Acoustic power level according to directive 2000/14/CE
2. Conformity mark according to directive 2006/42/CE
3. Year of manufacture
4. Operating engine power and speed
5. Type of machine
6. Serial number
7. Weight in kg
8. Name and address of manufacturer
9. Type of transmission (if indicated)
10. Article Code

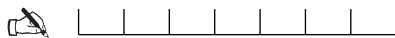
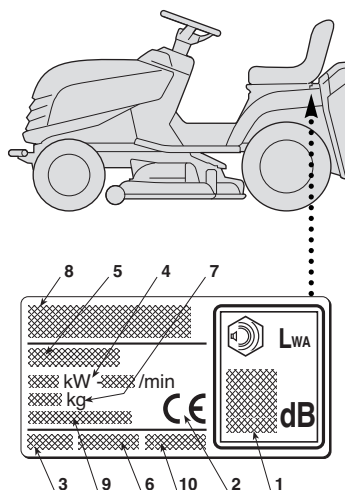

Write your machine's serial number here (6)

2.2 IDENTIFICATION OF MAIN COMPONENTS

The main components of the machine have the following functions:

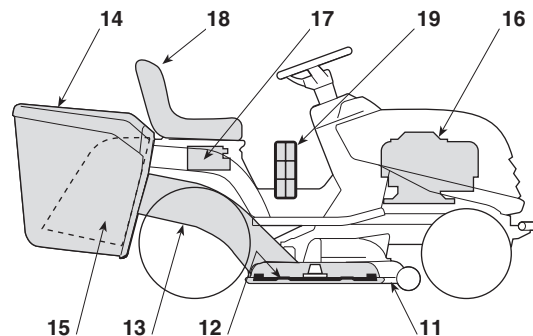

11. **Cutting deck:** this is the guard housing the rotating blades.
12. **Blades:** these are what cut the grass. The wings at the ends help convey the cut grass towards the collector channel.
13. **Collector channel:** this is the part connecting the cutting deck to the grass-catcher.
14. **Grass-catcher:** as well as collecting the grass cuttings, this is also a safety element that stops any objects drawn up by the blades from being thrown outside of the machine.

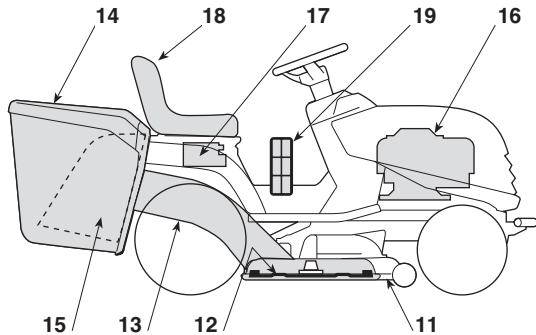

- 15. Stone-guard or deflector (optional):** this can be fitted in place of the grass-catcher and prevents objects drawn up by the blades from being thrown outside of the machine.
- 16. Engine:** this moves the blades and drives the wheels. Its specifications and regulations for use are described in a specific manual.
- 17. Battery:** provides the energy for starting the engine. Its specifications and regulations for use are described in a specific manual.
- 18. Driving seat:** this is where the machine operator sits. It has a sensor connected to safety devices for detecting the presence of the operator.
- 19. Regulation and safety labels:** give reminders on the main regulations for working safely, each of which is explained in chapter 1.

3. UNPACKING AND ASSEMBLY

For storage and transport purposes, some components of the machine are not installed in the factory and have to be assembled after unpacking. Follow the instructions below.

IMPORTANT

The machine is supplied without engine oil or fuel. Before starting the engine, fill with oil and fuel following the instructions given in the engine manual.

WARNING!

Unpacking and completing the assembly should be done on a flat and stable surface, with enough space for machine handling and its packaging, always making use of suitable equipment.

3.1 UNPACKING

When unpacking the machine, take care to gather all individual parts and fittings, and do not damage the cutting deck when taking the machine off the pallet.

The packaging contains:

- the machine;
- the steering wheel;
- the dashboard cover;
- the seat;
- the front bumper (if not preassembled in factory);
- the battery;
- the grass-catcher (with instructions);
- the lower part of the rear plate, the grass-catcher brackets and accessories necessary for completing and assembly;

- an envelope containing:
 - the operator's manuals and documents,
 - steering wheel assembly parts and seat assembly bolts and screws,
 - the connection screws for the battery cables
- 2 starter keys,
- 1 spare 10 A fuse.

NOTE

To prevent damage to the cutting deck, raise it to its maximum height and take utmost care when taking the machine off the pallet.



Hydrostatic transmission

- To make it easier to get the machine off the pallet and to move it, the drive disengage lever should be put in position «B» (☛ 4.33).

Disposal of the packaging should be done in accordance with the local regulations in force.

3.2 FITTING THE STEERING WHEEL

Put the machine on a flat surface and straighten up the front wheels.

Mount the hub (1) on the shaft (2), making sure that the plug (3)

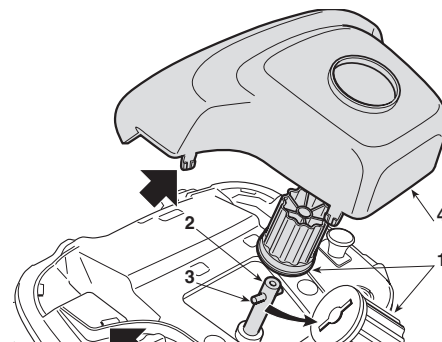

is correctly fitted into the hub seat.

Fit the dashboard cover (4) clicking the seven fasteners into place.

Fit the steering wheel (5) onto the hub (1) with the spokes directed towards the seat.

Fit the spacer (6) and fasten the steering wheel in place using the screws supplied (7), in the indicated order.

Fit the steering wheel cover (8) clicking the three fasteners into place.

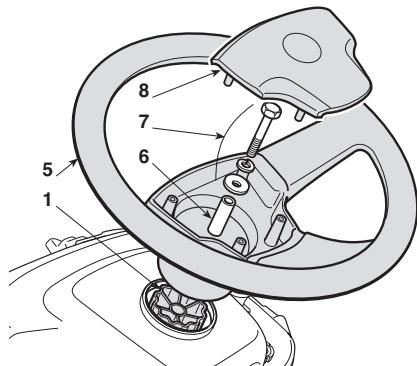

3.3 FITTING THE SEAT

Mount the seat (1) on the plate (2) using the screws (3).

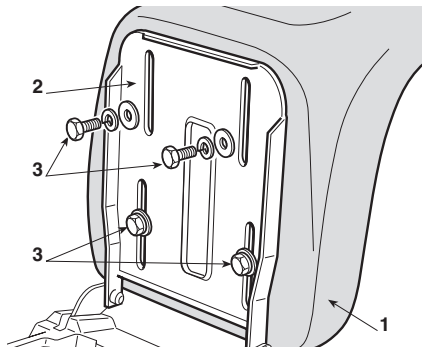

3.4 ASSEMBLY AND CONNECTING THE BATTERY

The battery (1) is housed under the seat and secured by a spring (2).

First connect the red wire (3) to the positive pole (+) and then the black wire (4) to the negative pole (-), using the screws supplied as shown.

Apply silicone grease to the terminals and check that the protective cap for the red wire (8) is in place.

IMPORTANT Always fully charge the battery according to the instructions in the battery's manual (☛ 6.2.3).

IMPORTANT To prevent the safety device in the electronic circuit board from cutting in, never start the engine until the battery is fully charged!

⚠ WARNING! Do not use the machine without the guard (2) or with the battery incorrectly fixed in its housing.

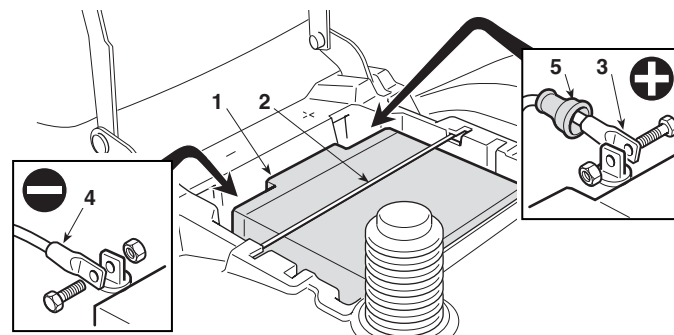

3.5 MOUNTING THE FRONT BUMPER (if provided)

Mount the front bumper (1) on the bottom of the frame (2) using the four screws (3).

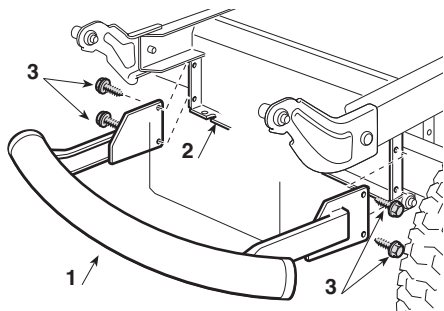

3.6 ASSEMBLY AND COMPLETING THE REAR PLATE

Assemble the two lower brackets (1) and (2), following the assembly direction as shown in the illustration, and fasten them with the screws (3) and nuts (4), tightening them completely.

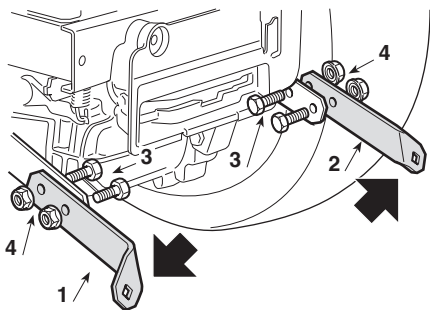

Remove the two screws (8), which will be used later.

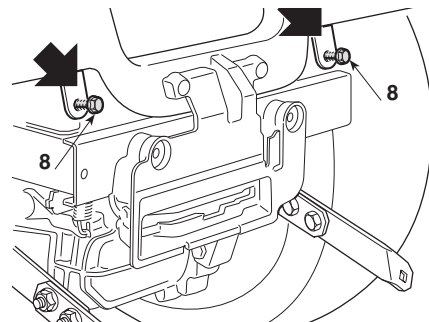

Assemble the lower part (5) of the rear plate and fasten it to the lower brackets with the screws (6) and bolts (7), without tightening them completely.

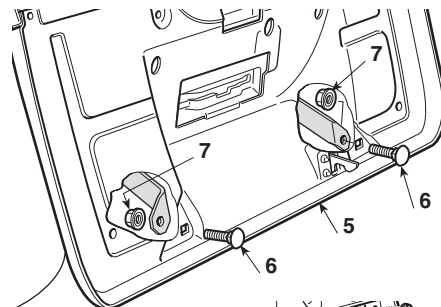

Finish fastening the lower part (5) of the rear plate, completely tightening the two central screws (8) that you previously removed and the four upper screws (9); then tighten the two lower nuts (7) completely.

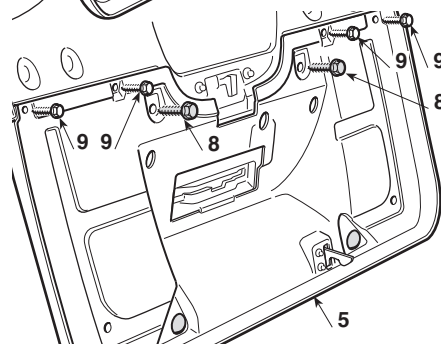

Insert the lever (11) of the “grass-catcher full” indicator into its seat (12) and push it down until you hear a click.

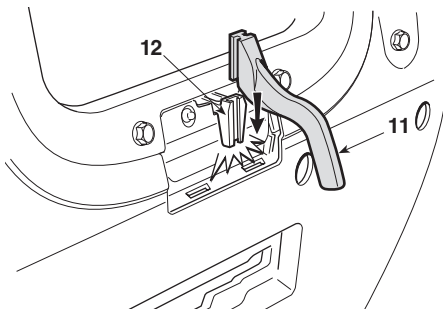

Assemble the two grass-catcher brackets (21) and (22), following the assembly direction as shown in the illustration, and fasten them with the screws (23) and snap washers (24), tightening them firmly.

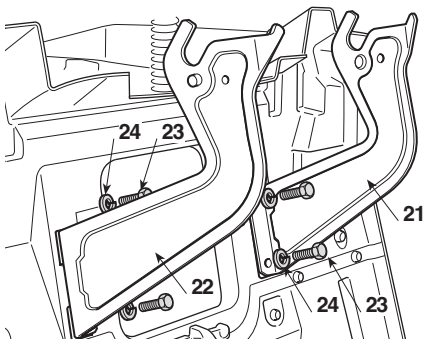

4. CONTROLS AND INSTRUMENTS

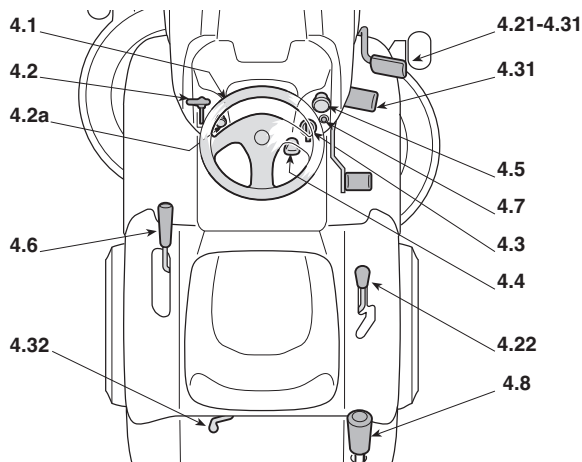





4.1 STEERING WHEEL

Turns the front wheels.

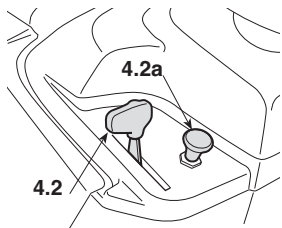
4.2 THROTTLE

This regulates the engine's r.p.m. The positions are indicated on a plate showing the following symbols:



-  «CHOKE» cold starting
-  «SLOW» for minimum engine speed
-  «FAST» for maximum engine speed

- The «CHOKE» position enriches the mixture so must only be used for the time necessary when starting from cold.
- When moving from one area to another, put the lever in a position between «SLOW» and «FAST».
- When cutting, shift into «FAST».





4.2a CHOKE CONTROL (if fitted)

It enriches the mixture and must only be used for the necessary time for cold starting.

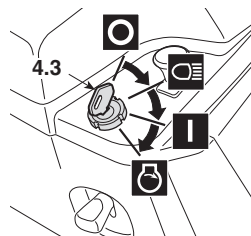
4.3 KEY IGNITION SWITCH

This key operated control has four positions:



-  «OFF» everything is switched off;
-  «HEADLIGHTS ON» (if fitted);
-  «ON» activates all parts;
-  «START» connects the starter motor.

- If you release the key on «START», it will automatically return to «ON».
- After turning the engine on, turn the lights on (if fitted) by turn-

- ing the key to the «HEADLIGHTS ON» position.
- to switch them off, turn the key to «ON».

4.4 PARKING BRAKE

This brake stops the machine from moving when it has been parked.

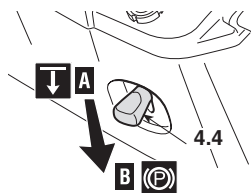

There are two positions:

↓ «A» = Brake off

Ⓟ «B» = Brake on

- The brake is applied by pressing the pedal right down (4.21 or 4.31) and moving the lever to position «B». When you take your foot off the pedal it will be blocked by the lever in the lowered position.
- To disengage the parking brake, press the pedal (4.21 or 4.31). The lever will return to position «A».

4.5 BLADE ENGAGEMENT AND BRAKE CONTROL

The mushroom switch allows you to engage the blades using the electromagnetic clutch:

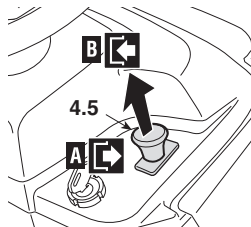

➡ «A» Pressed = Blades disengaged

⬅ «B» Pulled = Blades engaged

- If you engage the blades without taking the necessary safety precautions, the engine shuts down and cannot be restarted (☛ 5.2).

- Blade disengagement (Pos. «A»), simultaneously activates a brake which stops their rotation in a few seconds.

4.6 CUTTING HEIGHT ADJUSTMENT LEVER

There are seven positions for this lever (shown as «1» to «7» on the label), which correspond to various heights between 3 and 8 cm.

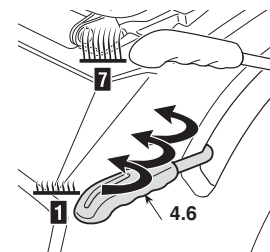

- To go from one position to another, move the lever sideways and put it back in one of the stop notches.

4.7 LIGHT AND SOUND WARNING DEVICE

- The sound warning indicates that the grass-catcher is full (☛ 5.4.6).

This light comes on when the key (4.3) is in the “ON” position and stays on while the machine is running.

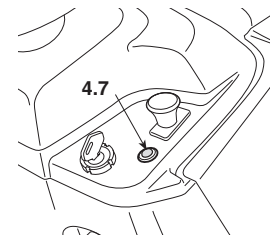

- When it flashes, this means the engine is not ready to be started (☛ 5.2).

4.8 LEVER FOR TIPPING THE GRASS-CATCHER (if present)

This pull-out lever tips and empties the grass-catcher. This means less work for the operator.

Mechanical transmission

4.21 CLUTCH / BRAKE PEDAL

This pedal has two functions: during the first part of its travel it acts as a clutch, engaging and disengaging drive to the wheels, and in the second part it acts as a brake on the rear wheels.

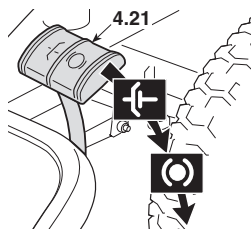

IMPORTANT

Do not keep the pedal halfway between clutch engagement or disengagement, as this can cause overheating and damage the transmission belt.

NOTE

When the machine is moving, keep your foot off the pedal.

4.22 SPEED CHANGE LEVER

This lever has seven positions for the 5 forward speeds, the neutral position «N», and reverse «R».

To go from one speed to another, press the pedal (4.21) halfway and shift the lever as shown on the label.

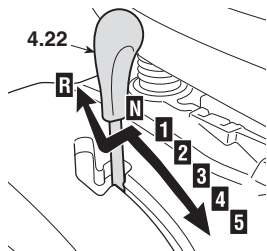

⚠ WARNING! *Only shift into reverse when the machine has stopped moving.*

Hydrostatic transmission

4.31 BRAKE PEDAL

This pedal works the brake on the rear wheels.

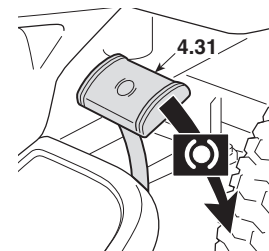

4.32 DRIVE PEDAL

This pedal engages drive in the wheels and controls the machine's forward and reverse speeds.

– To engage forward drive, press it towards «F» with your toe-cap. As you increase the pressure on the pedal, the speed of the machine increases.

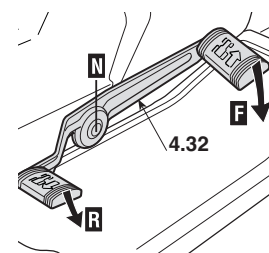

– Reverse is engaged by pressing the pedal with the heel towards «R».

– The pedal automatically goes into neutral «N» when released.

⚠ WARNING! *Only shift into reverse when the machine has stopped moving.*

NOTE

If the drive pedal is used, whether forwards or for reverse, the engine stops as soon as the parking brake (4.4) is engaged.

4.33 HYDROSTATIC TRANSMISSION DISENGAGEMENT LEVER

This lever has two positions:

⊗ ⊗ «A» = Transmission engaged: for all uses, when moving and during cutting;

⊗ ↔ ⊗ «B» = Transmission disengaged: this makes it much easier to move the machine by hand, **with the engine turned off.**

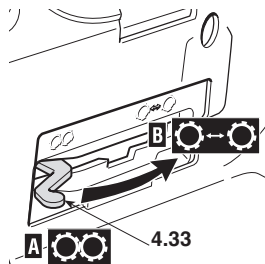

IMPORTANT

To avoid damage to the transmission unit, this operation must be carried out only when the engine has stopped with the pedal (4.32) on position «N».

5. HOW TO USE THE MACHINE

5.1 SAFETY RECOMMENDATIONS

⚠ DANGER! *The machine must only be used for the purpose for which it was designed (cutting and collecting grass).*

Using the machine in any other way is considered “improper use” which will invalidate the warranty, relieve the manufacturer from all liabilities, and the user will consequently be liable for all and any damage or injury to himself or others.

Examples of improper use may include, but are not limited to:

- *transport people, children or animals on the machine or on a trailer;*
- *tow or push loads without the use of the specified accessory for towing;*
- *use of the machine for moving over unstable, slippery, icy, stony, rough, marshy ground and puddles that do not allow for evaluation of the consistency of the ground;*
- *use of the machine for leaf or debris collection;*
- *use of the blades on surfaces other than grass.*

⚠ DANGER! *Do not tamper with or remove the safety devices fitted on the machine. REMEMBER THAT THE USER IS ALWAYS RESPONSIBLE FOR DAMAGE AND INJURY TO OTHERS. Before using the machine:*

- *read the general safety regulations (☛ 1.2), paying particular attention to driving and cutting on slopes;*
- *carefully read the instructions for use, make sure you are familiar with the controls and know how to stop the blades and the engine quickly;*
- *never put your hands or feet next to or beneath the ro-*

tating parts and always keep away from the exit. Do not use the machine when in a precarious state of health or under the effect of medicine or any other substances that can reduce your reflex actions and your ability to concentrate.

It is the user's responsibility to assess the potential risk of the area where work is to be carried out, and to take all the necessary precautions to ensure his own safety and that of others, particularly on slopes or rough, slippery and unstable ground.

Do not leave the machine on high grass with the engine running to avoid the risk of starting a fire.

⚠ WARNING! *This machine must not be used on slopes steeper than 10° (17%) (☛ 5.5). If the machine is likely to be used mostly on sloping ground (never steeper than 10°), fit counterweights (supplied on request (☛ 9.1) beneath the cross-member of the front wheels. These improve stability at the front and reduce the chances of tipping over.*

IMPORTANT *All the references relating to the positions of controls are described in chapter 4.*

5.2 WHY THE SAFETY DEVICES CUT IN

The safety devices work in two ways:

- *hey prevent the engine from starting if all the safety requirements have not been met;*
- *they stop the engine if even just one of the safety requirements is lacking.*

a) To start the engine, it is necessary that:

- the transmission is in “neutral”;
- the blades are not engaged;
- the operator is seated or the parking brake is engaged.

b) The engine stops when:

- the operator leaves his seat when the blades are engaged;
- the operator leaves his seat when the transmission is not in “neutral”;
- the operator leaves his seat with the transmission in “neutral” but without applying the parking brake;
- the grass-catcher is lifted or the stone-guard is removed when the blades are engaged;
- the parking brake is engaged without disengaging the blades;
- the speed change is activated (☛ 4.22) or the drive pedal (☛ 4.32) with the parking brake on.

5.3 DIRECTIONS BEFORE STARTING WORK

Before starting to mow, it is necessary to carry out several checks and operations to ensure you can work efficiently and in maximum safety.

5.3.1 Seat adjustment

To change the seat position, loosen the four fixing bolts (1) and slide it along the slots.

Once you have found the right position, tighten the four screws (1).

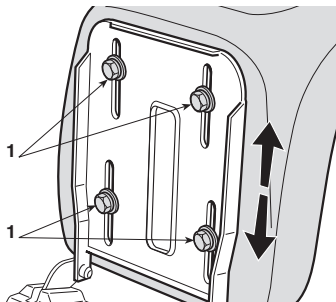

5.3.2 Tyre pressure

Having the right tyre pressure is the main condition for ensuring that the cutting deck is horizontal and mows evenly.

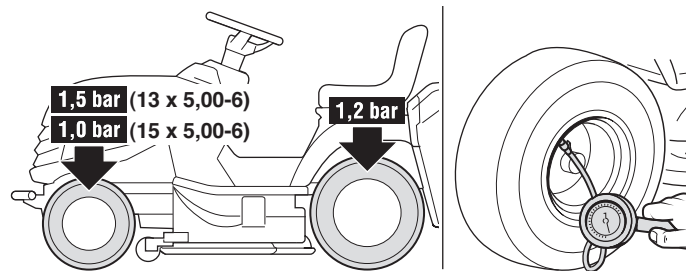

Unscrew the valve caps and connect a compressed air line with a gauge to the valves and adjust the pressure to the indicated values.

5.3.3 Filling with oil and fuel

NOTE

The engine manual indicates what type of oil and fuel you can use.

With the engine off, check the oil level. According to the instructions in the engine manual, this must be between the MIN and MAX marks on the dipstick.

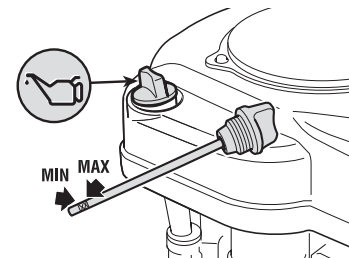

Refuel using a funnel, but do not completely fill the tank. The tank's capacity is about 6.5 liters.

⚠ DANGER! *Refuelling should be carried out in an open or well-ventilated area with the engine off. Always remember that petrol fumes are inflammable. DO NOT USE A NAKED FLAME TO LOOK INSIDE THE TANK AND DO NOT SMOKE WHEN REFUELLING.*

IMPORTANT *Do not drip petrol onto the plastic parts to avoid damaging them. In the event of accidental spills or leaks, rinse immediately with water. The warranty does not cover for damage to plastic parts of the bodywork or the engine caused by petrol.*

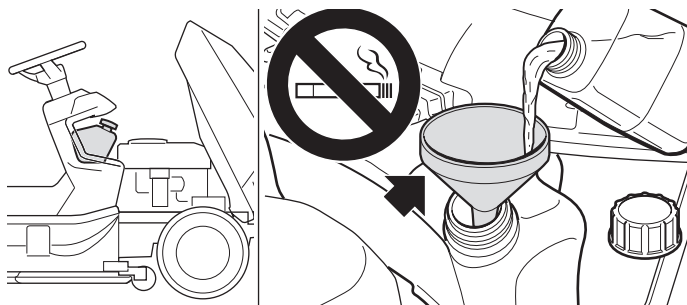

5.3.4 Fitting the protection at the exit (grass-catcher or stone-guard)

⚠ WARNING! *Never use the machine without having fitted the exit guards!*

Fasten the grass-catcher (1) to the brackets (2) and centre it with regard to the rear plate.

Centering is ensured by using the right bracket as lateral support.

Make sure that the lower pipe of the grass-catcher opening is attached to the pawl (3).

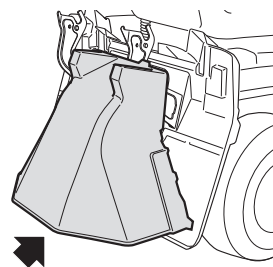
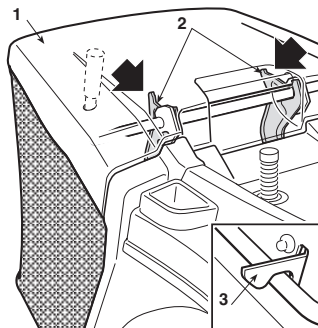

If you decide to mow without the grass-catcher, you can mount an optional stone-guard kit (➔ 9.2). This has to be attached to the rear plate as indicated in the instructions.

5.3.5 Checking machine safety and efficiency

1. Check that the safety devices function as described (➔ 5.2).
2. Check that the brake is in perfect working order.
3. Do not start mowing if the blades vibrate or if you are unsure whether they are sharp enough. Always remember that:
 - A badly sharpened blade pulls at the grass and causes the lawn to turn yellow.
 - A loose blade causes unwanted vibrations and can be dangerous.

⚠ WARNING! *Do not use the machine if you are unsure whether it is working safely or efficiently. If in doubt, contact your Dealer immediately to make the necessary checks and repairs.*

5.4 USING THE MACHINE

5.4.1 Starting

⚠ DANGER! *The engine must be started in an open or well-ventilated area! ALWAYS REMEMBER THAT EXHAUST GASES ARE TOXIC!*

To start the engine:

- open the fuel stopcock (1) (if fitted);
- shift in the gear into neutral («N») (☛ 4.22 or 4.32);
- disengage the blades (☛ 4.5);
- apply the parking brake on sloping ground;
- for cold starting, operate the choke (☛ 4.2 or 4.2a);
- if the engine is already warm, position the lever between «SLOW» and «FAST»;
- put in the ignition key and turn to «ON» to make electrical contact, then turn to «START» to start the engine;
- release the key once the engine has started.

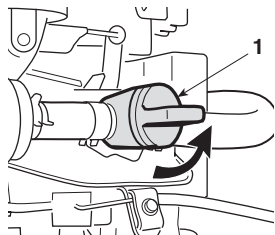

When the engine has started, move the throttle to «SLOW».

IMPORTANT *The choke must be closed as soon as the engine is running smoothly. Using it when the engine is already warm can foul the spark plugs and cause the engine to run erratically.*

NOTE *If there are engine starting problems, do not insist as you can risk running the battery flat and flooding the engine. Turn the key to «OFF», wait for a few seconds and then repeat the operation. If the malfunction persists, refer to the engine manual and chapter «8» in this manual.*

IMPORTANT *Always bear in mind that the safety devices prevent the engine from starting if safety requirements have not been met (☛ 5.2). In these cases, once the situation has been corrected, the key must first be turned back to «OFF» before the engine can be restarted.*

5.4.2 Starting and moving without mowing

⚠ WARNING! *This machine has not been approved for use on public roads. It has to be used (as indicated by the highway code) in private areas closed to traffic.*

When moving the machine:

- disengage the blades;
- bring the cutting deck to the highest position (position «7»);
- put the accelerator control between the «SLOW» and «FAST» positions.

➤ **Mechanical transmission**

- Push the pedal down as far as possible (☛ 4.21) and move the gear change lever into 1st gear (☛ 4.22).
- Keep the pedal pressed down and release the parking brake.
- Slowly release the pedal to shift from «brake» to «clutch», thus operating the rear wheels (☛ 4.21).

⚠ WARNING! *The pedal has to be released gradually, as a sudden engagement may cause the vehicle to tip over and the driver to lose control.*

- Gradually reach the desired speed using the throttle and gear lever. To change gear, press the clutch halfway down (☛ 4.21).

➤ **Hydrostatic transmission**

- Disengage the parking brake and release the brake pedal (☛ 4.31).
- Press the drive pedal (☛ 4.32) in direction «F» and reach the required speed by progressively increasing pressure on the pedal and moving the accelerator.

⚠ WARNING! *Drive must be engaged as described (☛ 4.32) to prevent sudden engagement from causing tipping up and loss of control of the vehicle, particularly on slopes.*

5.4.3 Braking

First reduce the machine's speed by reducing the engine's r.p.m., and then press the brake pedal (☛ 4.21 or 4.31) to slow down the machine until it stops.

➤ **Hydrostatic transmission**

- The machine already slows down considerably by just releasing the drive pedal.

5.4.4 Reverse

IMPORTANT *Reverse must be engaged only when the machine has stopped moving.*

➤ **Mechanical transmission**

- Press the pedal until the machine stops and then go into reverse by shifting the lever sideways and into position «R» (☛ 4.22). Gradually release the pedal to engage the clutch and then begin moving in reverse.

➤ **Hydrostatic transmission**

- When the machine has stopped moving, start reversing by pressing the drive pedal in direction «R» (☛ 4.32).

5.4.5 Grass cutting

Adjust the position of the anti-scalp wheels (1- if provided) whose function is to reduce the risk of tearing up sections of lawn, which occurs when the edge of the cutting deck drags over irregular ground.

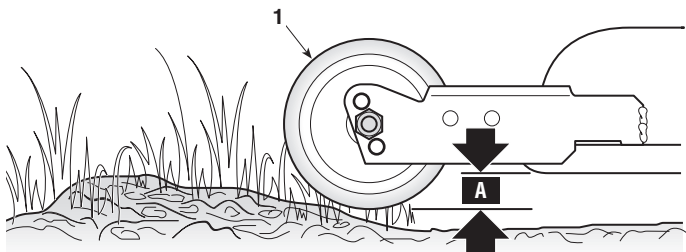

The three front wheel assembly positions allow you to maintain a safe distance «A» between the cutting deck edge and the ground.

To change position, unscrew the nut (2) and extract the pin (3).

Reposition the wheel (1) to the desired position, then reassemble the pin (3), making sure the pin (3) head is facing toward the inside of the machine; then tighten the nut completely.

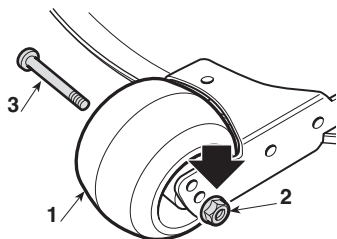

⚠ WARNING! *This work is to be done to both wheels, WITH THE ENGINE OFF AND THE BLADES DIS-ENGAGED.*

To start cutting:

- move the throttle to «FAST»;
- raise the cutting deck as high as possible;

- only use the blade (☛ 4.5), on grass lawns, do not use the blades on stony ground or when the grass is very high.
- start moving forwards on the grass very slowly and with utmost caution, as already described;
- regulate the cutting height and speed (☛ 4.8) considering the conditions of the lawn (the height, density and dampness of the grass).

⚠ WARNING! *When cutting on sloping ground, reduce your speed to ensure safe conditions (☛ 1.2 - 5.5).*

Whatever the conditions, always reduce the speed if you notice a drop in engine speed – if you travel too fast compared to the amount of grass being cut, you will not be able to mow the grass well.

Disengage the blades and raise the cutting deck as high as possible whenever you need to get past an obstacle.

5.4.6 Emptying the grass-catcher

NOTE *This operation can only be done with the blades disengaged, otherwise the engine stops.*

Do not let the grass-catcher become too full as this may block the collector channel.

When the grass-catcher is full you will hear a sound warning. At this point:

- disengage the blades (☛ 4.5) and the sound will stop;
- lower the engine speed;

- shift into neutral (N) (☛ 4.22 **Mechanical transmission** or 4.32 **Hydrostatic transmission**) and stop moving forward;
- engage the parking brake on slopes;
- pull out the lever (1- *if fitted*) or grasp the rear handle (1a) and tip up the grass-catcher to empty it;
- close the grass-catcher so that it hooks onto the pawl (2).

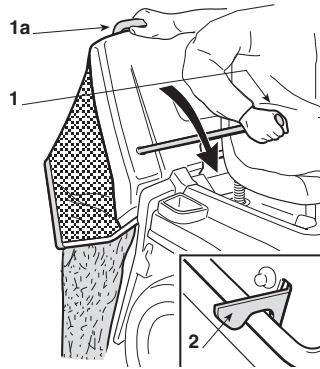

5.4.7 Unblocking the collector channel

Cutting very tall or wet grass, particularly at excessively high speed, can clog up the collector channel. If this happens proceed as follows:

- stop moving forward, disengage the blades and stop the engine;
- remove the grass-catcher or stone-guard;
- remove the grass cuttings; you can reach them from the exit of the collector channel.

⚠ WARNING! *This job must only be performed with the engine turned off.*

5.4.8 End of mowing

When you have finished mowing, disengage the blades, lower the engine speed and ride the machine with the cutting deck raised as high as possible.

5.4.9 End of work

Stop the machine, move the throttle to «SLOW» and turn off the engine by turning the key to «OFF».

⚠ WARNING! *To avoid backfire, position the throttle on «SLOW» for 20 seconds before stopping the engine.*

When the engine has stopped, close the fuel stopcock (1) (*if fitted*).

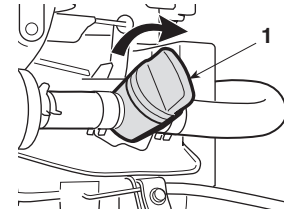

⚠ WARNING! *Always take out the ignition key before leaving the machine unattended!*

IMPORTANT *To keep the battery charged, do not leave the key in the «ON» position or «HEADLIGHTS ON» when the engine is not running.*

5.4.10 Cleaning the machine

After each mowing, clean the outside of the machine, empty the grass-catcher and shake it to remove residual grass and earth.

⚠ WARNING! *Always empty the grass-catcher and do not leave containers full of cut grass inside a room.*

Clean the plastic parts of the body with a damp sponge using water and detergent, taking care not to wet the engine, the electrical parts or the electronic circuit board located under the dashboard.

IMPORTANT

Never use hose nozzles or harsh detergents to clean the bodywork or the engine!

⚠ WARNING!

Do not let debris and dry remains of grass accumulate in upper part of the cutting deck in order to keep maximum machine efficiency and safety levels.

After each use, accurately clean the cutting deck to remove any grass remains or debris.

⚠ WARNING!

Wear eye protection and keep people or animals away from the surrounding area when cleaning the cutting deck.

a) When washing the inside of the cutting deck and the collector channel, the machine must be on firm ground with:

- the grass-catcher or stone-guard fitted;
- the operator seated;
- the cutting deck has been completely lowered;
- the engine running;
- the transmission in neutral;
- the blades engaged.

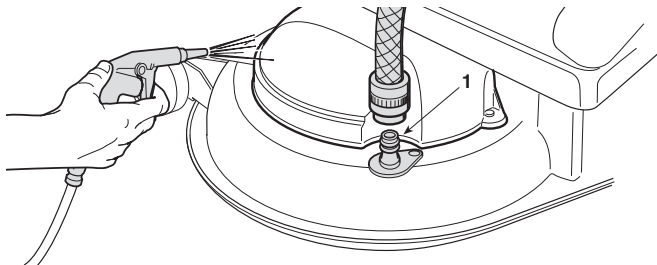

Connect a water hose to each of the pipe fittings (1) one at a time and run water through each one for a few minutes, with the blades moving.

IMPORTANT

To avoid impairing the efficient working of the electromagnetic clutch:

- prevent the friction from coming into contact with oil;
- do not direct jets of high-pressure water directly onto the clutch unit;
- do not clean the clutch with petrol.

Take off the grass-catcher, empty and rinse it, and then put it in a position where it can dry quickly.

b) To clean the upper part of the cutting deck:

- lower the cutting deck completely (position «1»);
- blow a jet of compressed air through the right and left guard slots.

5.4.11 Storage and inactivity for long periods

If you intend not to use the machine for a long period (more than 1 month), disconnect the battery cables and follow the instructions in the engine instruction manual.

Empty the fuel tank by disconnecting the tube (1) situated at the inlet of the fuel filter (2), and collect the fuel in a suitable container.

Reconnect the tube (1) making sure you position the clip properly (3).

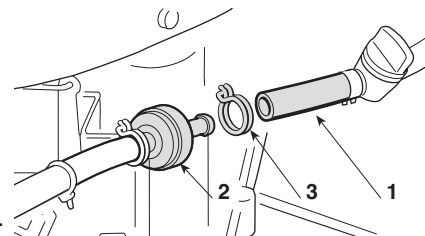

⚠ WARNING! *Carefully remove any dry grass cuttings which may have collected around the engine or silencer to prevent their catching fire the next time the machine is used!*

Put the machine away in a dry, sheltered place and preferably covered with a cloth (☛ 9.3).

IMPORTANT *The battery must be kept in a cool and dry place. Before a long storage period (more than 1 month), always charge the battery, and then recharge before using again (☛ 6.2.3).*

The next time the machine is used, check that there are no fuel leaks from the tubes, fuel stopcock or carburettor.

5.4.12 Card protection device

The electronic circuit board has a self-resetting protector which breaks the circuit if there is a fault in the electrical system. This will stop the engine and switch off the light.

The circuit automatically resets after a few seconds but the cause of the fault should be ascertained and dealt with to avoid reactivating the protection device.

IMPORTANT *To avoid activating the protection device:*

- do not invert the leads on the battery terminals;
- do not use the machine without its battery or damage may be caused to the charging regulator;
- be careful not to cause short-circuits.

5.5 USING THE MACHINE ON SLOPING GROUND

Only mow on slopes with gradients up to the maximum already mentioned (**max 10° - 17%**). Lawns on a slope have to be mowed moving up and down and never across them. When changing direction, take great care that the wheels facing up the slope do not hit any obstacles (such as stones, branches, roots, etc.) that may cause the machine to slide sideways, tip over or make you lose control.

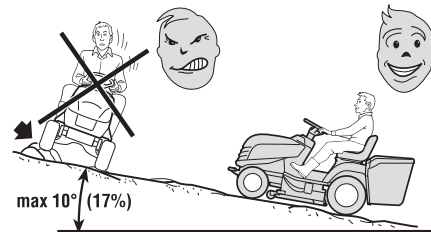

⚠ DANGER! *REDUCE SPEED BEFORE ANY CHANGE OF DIRECTION ON SLOPES, and always apply the parking brake before leaving the machine at a standstill and unattended.*

⚠ DANGER! *Start moving forwards very carefully on sloping ground to prevent the risk of tipping over. Reduce the forward speed before going on a slope, particularly downhill.*

⚠ DANGER! *Never use reverse to reduce speed going downhill: this could cause you to lose control of the vehicle, especially on slippery ground.*

☛ **Mechanical transmission**

⚠ DANGER! *Never ride the machine on slopes*

- **in neutral or with the clutch out! Always shift into a low gear before leaving the machine at a standstill and unattended.**

➔ **Hydrostatic transmission**

- Go down slopes with your foot off the drive pedal (☞ 4.32),
- to use the braking effect of the hydrostatic drive when the transmission is not engaged.

5.6 TRANSPORTING

⚠ WARNING! *If the machine is transported on a truck or trailer, use ramps with suitable resistance, width and length. Load the machine with the engine switched off, without a driver and pushed by an adequate number of people. During transport, close the fuel stopcock (if fitted), lower the cutting deck, engage the parking brake and fasten the machine securely with ropes or chains to the hauling device.*

5.7 LAWN MAINTENANCE

1. To keep a lawn green, soft and attractive, it should be cut regularly without damaging the grass. A lawn can be composed of different types of grass. If the lawn is cut frequently, grass and roots grow more vigorously, forming a solid grassy bed. If the lawn is cut less frequently, higher grass and weeds start growing (plus daisies and clovers, etc.).
2. It is always better to cut the grass when dry.
3. The blades must be in good condition and well sharpened so that the grass is cut straight without a ragged edge that leads to yellowing at the ends.

4. The engine must run at full speed, both to ensure a sharp cut of the grass and to get the necessary thrust to push the cuttings through the collector channel.
5. The frequency of mowing should be in relation to the rate of growth of the grass. The grass should not be left to grow too much between one cut and the next.
6. During hot and dry periods, the grass should be cut a little higher to prevent the ground from drying out.
7. The best height of the grass on a well-kept lawn is approx. 4-5 cm.

With one cut, you do not need to remove more than a third of the total height.

If the grass is very tall, it should be cut twice in a twenty-four hour period - the first time with the blades at maximum height, possibly reducing the cutting width, and the second cut at the desired height.

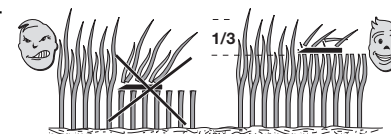
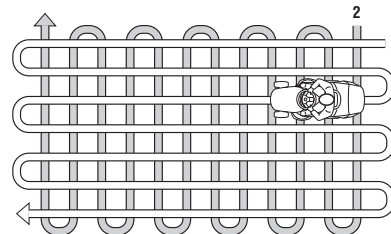

8. The appearance of the lawn will improve if you alternate cutting in both directions.
9. If the engine speed is lowered while you are cutting grass or if the cutting deck tends to get blocked, you should reduce the forward speed since this may be too high for the condition of the grass. If the problem persists, the probable causes are either badly sharpened blades or deformed wings.
10. Be very careful when mowing near bushes or kerbs as these could distort the horizontal position of the cutting deck and damage its edge as well as the blades.

6. MAINTENANCE

6.1 SAFETY RECOMMENDATIONS

⚠ WARNING! *Before cleaning or doing maintenance work, take out the ignition key and read the relevant instructions. Wear adequate clothing and work gloves whenever your hands are at risk.*

⚠ WARNING! *Never use the machine with worn or damaged parts. Faulty or worn-out parts must always be replaced and not repaired. Only use original spare parts: The use or non-original and/or incorrectly fitted parts will compromise the safety of the machine, may cause accidents or personal injuries for which the Manufacturer is under no circumstance liable or responsible.*

IMPORTANT *Never dispose of used oil, fuel, batteries or other pollutants in unauthorised places!*

⚠ WARNING! *Any adjustments or maintenance operations not described in this manual must be carried out by your Dealer or a specialized Service Centre. Both have the necessary knowledge and equipment to ensure that the work is done correctly without affecting the safety of the machine.*

All and any operations performed in unauthorised centres or by unqualified persons will totally invalidate the warranty and all obligations and responsibilities of the manufacturer.

You must go to a specialised Service Centre or contact your Dealer if the following are malfunctioning:

- *the brake;*
- *the engagement and stop of the blades;*
- *the drive engagement in forward and in reverse gears.*

6.2 ROUTINE MAINTENANCE

The table is to help you maintain your machine's safety and performance. It summarises the main interventions to be made and the frequency applicable to each of them.

The boxes at the side are for you to mark the date or number of working hours at which the intervention was made.

Operation	Hours	Completed (Date or Time)					
1. MACHINE							
Check of fastening and sharpness of blades ³⁾	25						
Blade replacement ³⁾	100						
Transmission belt check ³⁾	25						
Transmission belt replacement ^{2) 3)}	–						
Blade belt check ³⁾	25						
Blade belt replacement ^{2) 3)}	–						
Drive adjustment and check ³⁾	25						
Blade brake and engagement check ³⁾	25						
Bolt and screw check	25						
General lubrication ⁴⁾	25						
2. ENGINE ¹⁾							
Engine oil change						
Air filter cleaning and check						
Air filter replacement						
Fuel filter check						
Fuel filter replacement						
Spark plug contacts check and cleaning						
Spark plug replacement						

- 1) See the engine manual for the full list and frequency.
- 2) At the first signs of any malfunction, contact your Dealer immediately.
- 3) The operation must be carried out by your Dealer or a specialized Service Centre.
- 4) General lubrication should also be carried out whenever the machine is to be left unused for a long period.

6.2.1 Engine

IMPORTANT

Follow all the instructions in the engine manual.

To empty the oil from the engine, hold the extension tube (1) firmly in place and unscrew the drain plug (2).

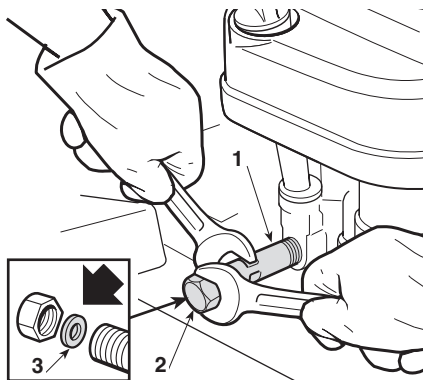

When refitting the plug (2) make sure the seal (3) is positioned correctly and tighten it as far as possible, holding the extension tube (1) firmly in place.

6.2.2 Rear axle

This is a sealed single unit that does not require maintenance. It is permanently lubricated and its lubricant does not need changing or topping up.

6.2.3 Battery

The battery must be carefully maintained to ensure long life. The machine battery must always be charged:

- before using the machine for the first time after purchase;
- before leaving the machine disused for a long period;
- before starting up the machine after a long period of disuse.

Carefully read and observe the battery recharging instructions in the booklet provided with the battery. Failure in following the instructions or in charging the battery could permanently damage the battery cells.

A flat battery **must** be recharged as soon as possible.

IMPORTANT

*Recharging must be done using a battery charger at **constant voltage**. Other recharging systems can irreversibly damage the battery.*

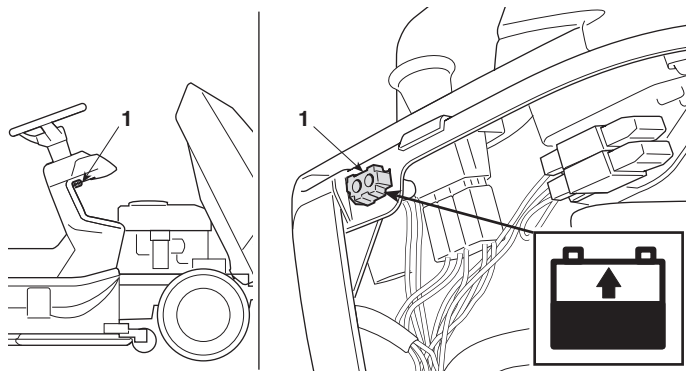

The machine comes with a connector (1) for recharging; this is connected to the corresponding connector for the special “CB01” or “FIGHTER” maintenance battery-charger supplied (if included) or available on request (☎ 9.2).

IMPORTANT

This connector must only be used for connection to the “CB01” or “FIGHTER” maintenance battery-charger. For its use:

- follow the instructions in the relevant user manual,
- follow the instructions in the battery manual.

6.3 INTERVENTIONS ON THE MACHINE

6.3.1 Cutting deck alignment

The cutting deck should be properly set to obtain an evenly cut lawn and reduce vibrations.

If the cut is uneven, check the tyre pressure.

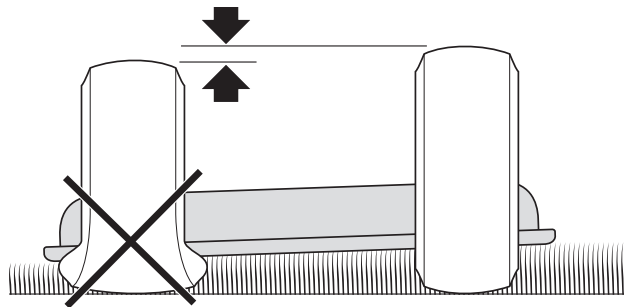

If this is not sufficient to achieve an even cut, please contact your Dealer who will test and make the necessary adjustments to the alignment of the cutting deck.

6.3.2 Replacing wheels

Stop the machine on flat ground and put a block under a load-bearing part of the frame on the side that the wheel is to be changed. The wheels are held by a snap ring (1) which can be eased off with a screwdriver.

NOTE

If you have to replace one or both rear wheels, make sure that any differences in their external diameter does not exceed 8-10 mm; on the contrary, to prevent an uneven cut it will be necessary to adjust the alignment of the cutting deck.

IMPORTANT

Before remounting the wheel, apply grease to the axle. Put the snap ring (1) and supporting washer (2) back in place.

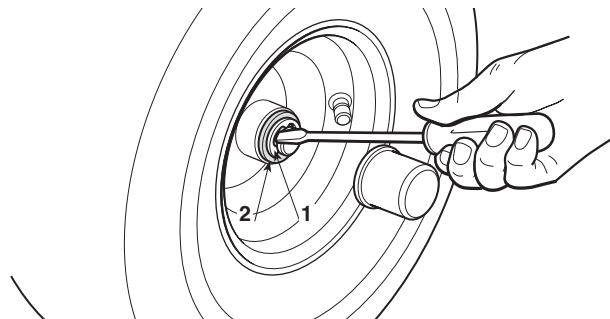

6.3.3 Replacing and repairing the tyres

The tyres are «Tubeless» and so all punctures must be repaired by a tyre repaireur following the procedures required for this kind of tyre.

6.3.4 Replacing the bulbs (if present)

The bulbs (18W) have a bayonet fitting and are installed in the bulb holder which can be taken out by turning it anti-clockwise with pliers.

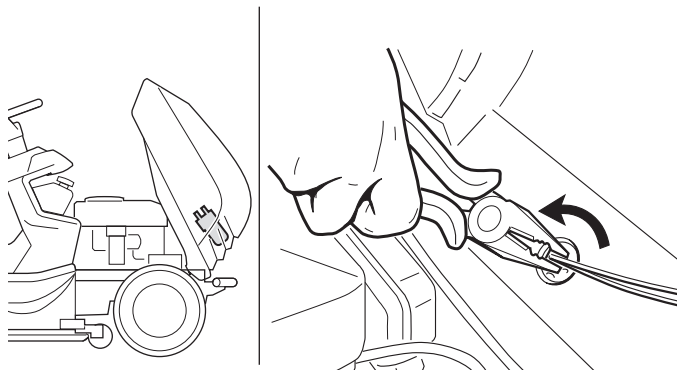

6.3.5 Replacing a fuse

The machine is fitted with fuses (1) with different capacities and functions. Specifically:

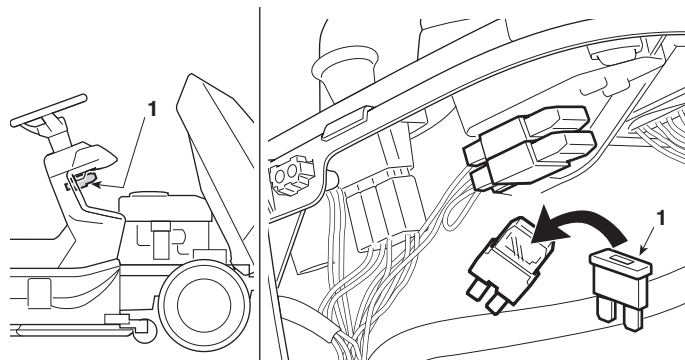

- 10 A fuse = protects the main and power circuits of the electronic board. When it blows, the machine stops.
- 25 A fuse = protects the battery charger circuit. When it blows, the battery gradually runs out and the machine will have problems starting.

The fuse capacity is indicated on the fuse.

IMPORTANT

A blown fuse must always be replaced by one of the same type and ampere rating, and never with one of another rating.

If problems persist, contact Your Dealer.

6.3.6 Dismantling, replacing and remounting the blades

⚠ WARNING! *Always wear work gloves when handling the blades.*

⚠ WARNING! *Damaged or bent blades must always be replaced; never try to repair them! ALWAYS USE ORIGINAL BLADES BEARING THE SYMBOL !*

Only blades with the following codes must be used on this machine:

82004358/0 - 82004359/0
82004360/0 - 82004361/0

IMPORTANT *Both of the blades should be replaced together, especially when there are slight differences in wear.*

7. ENVIRONMENTAL PROTECTION

Environmental protection should be a priority of considerable importance when using the machine, for the benefit of both social coexistence and the environment in which we live.

- Try not to cause any disturbance to the surrounding area.
- Scrupulously comply with local regulations and provisions for the disposal of waste materials after sawing.
- Scrupulously comply with local regulations and provisions for the disposal of oils, petrol, damaged parts or any elements which have a strong impact on the environment; this waste must not be disposed of as normal waste, it must be separated and taken to specified waste disposal centres where the material will be recycled.
- At the time of decommissioning, do not pollute the environment.

8. TROUBLESHOOTING

PROBLEM	LIKELY CAUSE	SOLUTION
1. With the key on «ON», the light stays off	<p>The safety device of the electronic circuit board has cut in due to:</p> <ul style="list-style-type: none"> - badly connected battery - battery terminals crossed - completely flat battery - fuse blown - electronic circuit board wet 	<p>Turn the key to «STOP» and look for the cause of the problem:</p> <ul style="list-style-type: none"> - check connections (☛ 3.4) - check connections (☛ 3.4) - recharge the battery (☛ 6.2.3) - replace the fuse (10 A) (☛ 6.3.5) - dry using tepid air
2. With the key on «START» the light flashes and the starter motor does not run	<ul style="list-style-type: none"> - conditions are not met to allow starting 	<ul style="list-style-type: none"> - check that the conditions allowing starting are met (☛ 5.2.a)
3. With the key is turned to «START» the light or the control panel come on, but the starter motor is not activated	<ul style="list-style-type: none"> - insufficiently charged battery - malfunction on the starter relay 	<ul style="list-style-type: none"> - recharge the battery (☛ 6.2.3) - contact Your Dealer
4. With the key on «START», the starter motor runs but the engine does not start	<ul style="list-style-type: none"> - insufficiently charged battery - faulty fuel supply - faulty ignition 	<ul style="list-style-type: none"> - recharge the battery (☛ 6.2.3) - check the level in the tank (☛ 5.3.3) - open the fuel stopcock (<i>if present</i>) (☛ 5.4.1) - check the fuel filter - check that spark plug cap is securely fitted - check that the electrodes are clean and have the correct gap
5. Starting is difficult or the engine runs erratically	<ul style="list-style-type: none"> - fault in carburation 	<ul style="list-style-type: none"> - clean or replace the air filter - empty the fuel tank and refill with fresh fuel - check and replace the fuel filter if necessary
6. Poor engine performance during cutting	<ul style="list-style-type: none"> - forward speed too high compared to cutting height (☛ 5.4.5) 	<ul style="list-style-type: none"> - reduce the forward speed and/or raise the cutting deck
7. The motor shuts down whilst working	<ul style="list-style-type: none"> - the safety devices have cut in 	<ul style="list-style-type: none"> - check that the conditions allowing starting are met (☛ 5.2.b)

PROBLEM	LIKELY CAUSE	SOLUTION
8. The blades do not engage or do not stop promptly when they are disengaged	problems with engagement mechanism	– contact Your Dealer
9. Uneven cut and poor grass collection	<ul style="list-style-type: none"> – cutting deck not parallel to the ground – blade cuts badly – forward speed too high compared to the height of the grass – collector channel is blocked 	<ul style="list-style-type: none"> – check the tyre pressure (☛ 5.3.2) – realign the cutting deck (☛ 6.3.1) – contact Your Dealer – reduce forward speed and/or raise the cutting deck (☛ 5.4.5) – wait for the grass to dry – remove the grass-catcher and empty the collector channel (☛ 5.4.7)
10. Unusual vibrations while working	<ul style="list-style-type: none"> – cutting deck is full of grass – blades are unbalanced or loose – bolts and screws are loose 	<ul style="list-style-type: none"> – clean the cutting deck (☛ 5.4.8) – contact Your Dealer – check and tighten all the engine and frame bolts
11. Uncertain or ineffective braking	– the brake is not adjusted correctly	– contact Your Dealer
12. Erratic forward movement, poor drive when going uphill or if the machine has a tendency to rear up	– problems with the belt or the engagement device	– contact Your Dealer
13. With the engine running, the machine does not move when the drive pedal is pressed (for hydrostatic drive models)	– move the disengagement lever to position «B»	– move it to position «A» (☛ 4.33)

If problems continue after having carried out these operations, contact your dealer.

⚠ WARNING! *Do not take on complicated repair work if you don't have the necessary equipment or the technical knowledge. The warranty is automatically voided and the manufacturer is not held responsible if repairs are done badly.*

9. ACCESSORIES ON REQUEST

1. "MULCHING" KIT

It chops the grass cuttings finely and leaves them on the lawn, instead of collecting them in the grass-catcher.

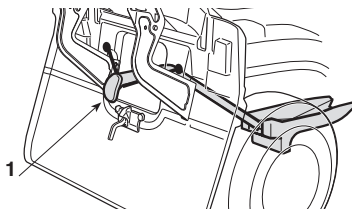

2. "CB01" OR "FIGHTER" MAINTENANCE BATTERY-CHARGER

This keeps the battery in good working order when the machine is in storage, guaranteeing an optimum level of charge and longer battery life.

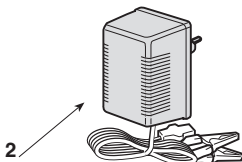

3. TOWING HITCH

For towing a small trailer.

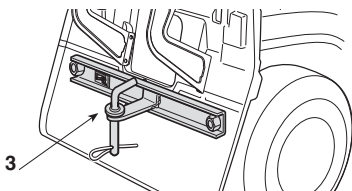

4. STONE-GUARD KIT

Used instead of the grass-catcher when the cuttings are not collected.

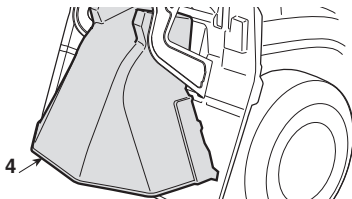

5. CLOTH COVER

Protects the machine from dust when not in use.

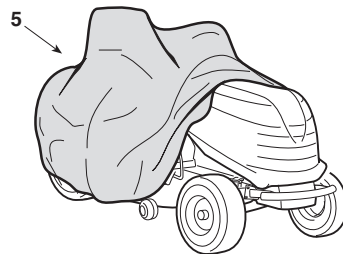

6. KITS FOR FRONT WEIGHTS

These improve the machine's front stability, particularly when used on slopes.

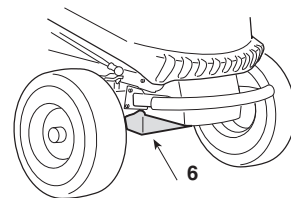

7. SNOW CHAINS

These improve front wheel adherence on snow-covered sections of road and allow the snow shovel equipment to be used.

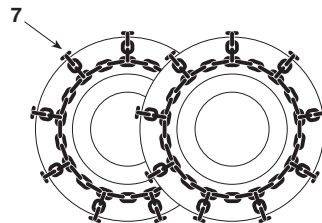

10. SUPPLEMENTARY EQUIPMENT

1. SNOW SHOVEL

Shovels and accumulates removed snow to the side.

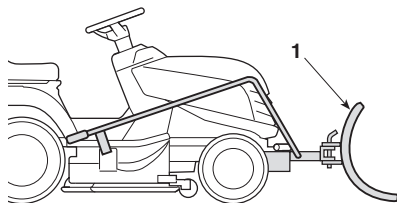

2. TRAILER

For transporting tools and other objects within the allowed load limits.

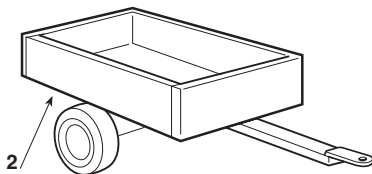

3. REAR WEIGHT KIT

This is indispensable for maintaining machine stability when supplementary front equipment is used.

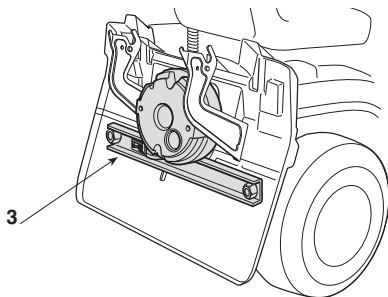

11. SPECIFICATIONS

Electrical system	12 V
Battery	18 Ah
Front tyres	13 x 5.00-6
or	15 x 5.00-6
Rear tyres	18 x 8.50-8
or	18 x 6.50-8
Front tyre pressure	
tyres 13 x 5.00-6	1.5 bar
tyres 15 x 5.00-6	1.0 bar
Rear tyre pressure	1.2 bar
Overall weight	from 180 to 187 kg
Inside turning circle (minimum diameter of uncut grass)	
left side	1.8 m
Cutting height	from 3 to 8.5 cm
Cutting width	83 cm

Mechanical transmission

Forward speed (approximate) at 3000 min ⁻¹ :	
in 1st	2.2 km/h
in 2nd	3.8 km/h
in 3rd	5.8 km/h
in 4th	6.4 km/h
in 5th	9.7 km/h
in Reverse	2.8 km/h

Hydrostatic transmission

Forward speed (approximate) at 3000 min ⁻¹ :	
in Forward gear	from 0 to 8.8 km/h
in Reverse	from 0 to 3.8 km/h

Maximum noise and vibration levels

MP 84C

Operator ear noise pressure level (according to regulation 81/1051/EEC)	db(A)	85.4
– Measurement uncertainty (2006/42/EC)	db(A)	1.1

Measured acoustic output level (according to directive 2000/14/EC, 2005/88/EC)	db(A)	99.6
– Measurement uncertainty (2006/42/EC)	db(A)	0.3

Guaranteed acoustic output level (according to directive 2000/14/EC, 2005/88/EC)	db(A)	100
---	-------	-----

Vibration level (according to the standard EN 1032)	m/s ²	0.68
– Measurement uncertainty (2006/42/EC)	m/s ²	0.3

