

TITAN[®]

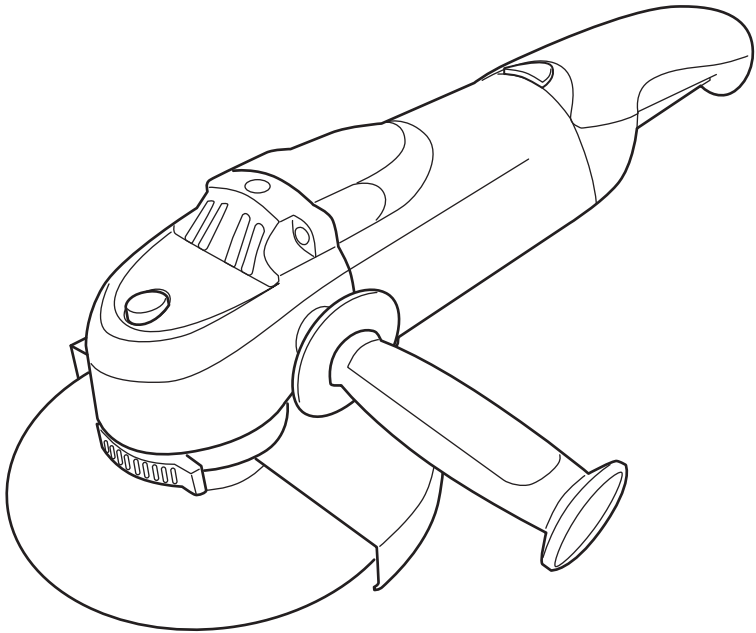

24 **month**
Manufacturer's
Warranty

SAFETY AND OPERATING MANUAL

Original instructions

ANGLE GRINDER 2350W TTB283GRD

TITAN®

Congratulations on your purchase of a TITAN. power tool from Titan Power Tools (UK) Ltd. We want you to continue getting the best performance from it so this handbook includes information on safety, handling and care. Please retain this handbook in case you need to refer to any of the information in the future.

Your TITAN. power tool comes with a 24-month guarantee, so should it develop a fault within this period contact your retailer.

GUARANTEE

This **TITAN.** product carries a guarantee of 24 months. If your product develops a fault within this period, you should, in the first instance contact the retailer where the item was purchased.

This guarantee specifically excludes losses caused due to:

- Fair wear and tear
- Misuse or abuse
- Lack of routine maintenance
- Failure of consumable items (such as batteries)
- Accidental damage
- Cosmetic damage
- Failure to follow manufacturer's guidelines
- Loss of use of the goods

This guarantee does not affect your statutory rights. This guarantee is only valid in the UK.

For any enquiries relating to the guarantee please refer to your retailer.

GENERAL SAFETY INSTRUCTIONS



WARNING! Read all safety warnings designated by the symbol  and all instructions.



WARNING! Read all safety warnings and all instructions. Failure to follow the warnings and instructions may result in electric shock, fire and/or serious injury. **Save all warnings and instructions for future reference.**

The term "power tool" in the warnings refers to your mains-operated (corded) power tool or battery-operated (cordless) power tool.

1. Work area safety

a. Keep work area clean and well lit. Cluttered or dark areas invite accidents.

b. Do not operate power tools in explosive atmospheres, such as in the presence of flammable liquids, gases or dust. Power tools create sparks which may ignite the dust or fumes.

c. Keep children and bystanders away while operating a power tool.

Distractions can cause you to lose control.

2. Electrical safety

a. Power tool plugs must match the outlet. Never modify the plug in any way. Do not use any adapter plugs with earthed (grounded) power tools.

Unmodified plugs and matching outlets will reduce risk of electric shock.

b. Avoid body contact with earthed or grounded surfaces, such as pipes, radiators, ranges and refrigerators. There is an increased risk of electric shock if your body is earthed or grounded.

c. Do not expose power tools to rain or wet conditions. Water entering a power tool will increase the risk of electric shock.

d. Do not abuse the cord. Never use the cord for carrying, pulling or unplugging the power tool. Keep cord away from heat, oil, sharp edges or moving parts. Damaged or entangled cords increase the risk of electric shock.

e. When operating a power tool outdoors, use an extension cord suitable for outdoor use. Use of a cord suitable for outdoor use reduces the risk of electric shock.

f. If operating a power tool in a damp location is unavoidable, use a residual current device (RCD) protected supply. Use of an RCD reduces the risk of electric shock.

3. Personal safety

a. Stay alert, watch what you are doing and use common sense when operating a power tool. Do not use a power tool while you are tired or under the influence of drugs, alcohol or medication. A moment of inattention while operating power tools may result in serious personal injury.

b. Use personal protective equipment. Always wear eye protection. Protective equipment such as dust mask, non-skid safety shoes, hard hat, or hearing protection used for appropriate conditions will reduce personal injuries.

c. Prevent unintentional starting. Ensure the switch is in the off-position before connecting to power source and/or battery pack, picking up or carrying the tool. Carrying power tools with your finger on the switch or energising power tools that have the switch on invites accidents.

d. Remove any adjusting key or wrench before turning the power tool on. A wrench or a key left attached to a rotating part of the power tool may result in personal injury.

e. Do not overreach. Keep proper footing and balance at all times. This enables better control of the power tool in unexpected situations.

f. Dress properly. Do not wear loose clothing or jewellery. Keep your hair, clothing and gloves away from moving parts. Loose clothes, jewellery or long hair can be caught in moving parts.

g. If devices are provided for the connection of dust extraction and collection facilities, ensure these are connected and properly used. Use of dust collection can reduce dust-related hazards.

4. Power tool use and care

a. Do not force the power tool. Use the correct power tool for your application. The correct power tool will do the job better and safer at the rate for which it was designed.

b. Do not use the power tool if the switch does not turn it on and off. Any power tool that cannot be controlled with the switch is dangerous and must be repaired.

c. Disconnect the plug from the power source and/or the battery pack from the power tool before making any adjustments, changing accessories, or storing power tools. Such preventive safety measures reduce the risk of starting the power tool accidentally.

d. Store idle power tools out of the reach of children and do not allow persons unfamiliar with the power tool or these instructions to operate the power tool. Power tools are dangerous in the hands of untrained users.

e. Maintain power tools. Check for misalignment or binding of moving parts, breakage of parts and any other condition that may affect the power tool's operation. If damaged, have the power tool repaired before use. Many accidents are caused by poorly maintained power tools.

f. Keep cutting tools sharp and clean. Properly maintained cutting tools with sharp cutting edges are less likely to bind and are easier to control.

g. Use the power tool, accessories and tool bits etc. in accordance with these instructions, taking into account the working conditions and the work to be performed. Use of the power tool for operations different from those intended could result in a hazardous situation.

5. Service

a. Have your power tool serviced by a qualified repair person using only identical replacement parts. This will ensure that the safety of the power tool is maintained.

ANGLE GRINDER SAFETY WARNINGS

SAFETY INSTRUCTIONS FOR ALL OPERATIONS

Safety Warnings Common for Grinding, Sanding, Wire Brushing, Polishing or Abrasive Cutting-Off Operations:

- a) **This power tool is intended to function as a grinder or cut-off tool. Read all safety warnings, instructions, illustrations and specifications provided with this power tool.** Failure to follow all instructions listed below may result in electric shock, fire and/or serious injury.
- b) **Operations such as wire brushing , sanding & polishing are not recommended to be performed with this power tool.** Operations for which the power tool was not designed may create a hazard and cause personal injury.
- c) **Do not use accessories which are not specifically designed and recommended by the tool manufacturer.** Just because the accessory can be attached to your power tool, it does not assure safe operation.
- d) **The rated speed of the accessory must be at least equal to the maximum speed marked on the power tool.** Accessories running faster than their rated speed can break and fly apart.
- e) **The outside diameter and the thickness of your accessory must be within the capacity rating of your power tool.** Incorrectly sized accessories cannot be adequately guarded or controlled.
- f) **The arbour size of wheels, flanges, backing pads or any other accessory must properly fit the spindle of the power tool.** Accessories with arbour holes that do not match the mounting hardware of the power tool will run out of balance, vibrate excessively and may cause loss of control.
- g) **Do not use a damaged accessory. Before each use inspect the accessory such as abrasive wheels for chips and cracks, backing pad for cracks, tear or excess wear, wire brush for loose or cracked wires. If power tool or accessory is dropped, inspect for damage or install an undamaged accessory. After inspecting and installing an accessory, position yourself and bystanders away from the plane of the rotating accessory and run the power tool at maximum no-load speed for one minute.**
Damaged accessories will normally break apart during this test time.
- h) **Wear personal protective equipment. Depending on application, use face shield, safety goggles or safety glasses. As appropriate, wear dust mask, hearing protectors, gloves and workshop apron capable of stopping small abrasive or workpiece fragments.** The eye protection must be capable of stopping flying debris generated by various operations . The dust mask or respirator must be capable of filtering particles generated by your operation. Prolonged exposure to high intensity noise may cause hearing loss.
- i) **Keep bystanders a safe distance away from work area. Anyone entering the work area must wear personal protective equipment.** Fragments of workpiece or of a broken accessory may fly away and cause injury beyond immediate area of operation.
- j) **Hold power tool by insulated gripping surfaces only, when performing an operation where the cutting accessory may contact hidden wiring or its own cord.** Cutting accessory contacting a "live" wire may make exposed metal parts of the power tool "live" and shock the operator.

- k) Position the cord clear of the spinning accessory.** If you lose control, the cord may be cut or snagged and your hand or arm may be pulled into the spinning accessory.
- l) Never lay the power tool down until the accessory has come to a complete stop.** The spinning accessory may grab the surface and pull the power tool out of your control.
- m) Do not run the power tool while carrying it at your side.** Accidental contact with the spinning accessory could snag your clothing, pulling the accessory into your body.
- n) Regularly clean the power tool's air vents.** The motor's fan will draw the dust inside the housing and excessive accumulation of powdered metal may cause electrical hazards.
- o) Do not operate the power tool near flammable materials.** Sparks could ignite these materials.
- p) Do not use accessories that require liquid coolants.** Using water or other liquid coolants may result in electrocution or shock.

KICKBACK AND RELATED WARNINGS

Kickback is a sudden reaction to a pinched or snagged rotating wheel, backing pad, brush or any other accessory. Pinching or snagging causes rapid stalling of the rotating accessory which in turn causes the uncontrolled power tool to be forced in the direction opposite of the accessory's rotation at the point of the binding.

For example, if an abrasive wheel is snagged or pinched by the workpiece, the edge of the wheel that is entering into the pinch point can dig into the surface of the material causing the wheel to climb out or kick out. The wheel may either jump toward or away from the operator, depending on direction of the wheel's movement at the point of pinching. Abrasive wheels may also break under these conditions.

Kickback is the result of power tool misuse and/or incorrect operating procedures or conditions and can be avoided by taking proper precautions as given below.

- a) Maintain a firm grip on the power tool and position your body and arm to allow you to resist kickback forces. Always use auxiliary handle, if provided, for maximum control over kickback or torque reaction during start-up.** The operator can control torque reactions or kickback forces, if proper precautions are taken.
- b) Never place your hand near the rotating accessory.** Accessory may kickback over your hand.
- c) Do not position your body in the area where power tool will move if kickback occurs.** Kickback will propel the tool in direction opposite to the wheel's movement at the point of snagging.
- d) Use special care when working corners, sharp edges etc. Avoid bouncing and snagging the accessory.** Corners, sharp edges or bouncing have a tendency to snag the rotating accessory and cause loss of control or kickback.
- e) Do not attach a saw chain woodcarving blade or toothed saw blade.** Such blades create frequent kickback and loss of control.

Additional safety instructions for grinding and cutting-off operations

Safety Warnings Specific for Grinding and Abrasive Cutting-Off Operations:

- a) Use only wheel types that are recommended for your power tool and the specific guard designed for the selected wheel.** Wheels for which the power tool was not designed cannot be adequately guarded and are unsafe.
- b) The guard must be securely attached to the power tool and positioned for maximum safety, so the least amount of wheel is exposed towards the operator.** The guard helps to protect operator from broken wheel fragments and accidental contact with wheel.

- c) Wheels must be used only for recommended applications. For example: do not grind with the side of cut-off wheel.** Abrasive cut-off wheels are intended for peripheral grinding, side forces applied to these wheels may cause them to shatter.
- d) Always use undamaged wheel flanges that are of correct size and shape for your selected wheel.** Proper wheel flanges support the wheel thus reducing the possibility of wheel breakage. Flanges for cut-off wheels may be different from grinding wheel flanges.
- e) Do not use worn down wheels from larger power tools.** Wheel intended for larger power tool is not suitable for the higher speed of a smaller tool and may burst.

ADDITIONAL SAFETY INSTRUCTIONS FOR CUTTING-OFF OPERATIONS

Additional Safety Warnings Specific for Abrasive Cutting-Off Operations:

- a) Do not "jam" the cut-off wheel or apply excessive pressure. Do not attempt to make an excessive depth of cut.** Overstressing the wheel increases the loading and susceptibility to twisting or binding of the wheel in the cut and the possibility of kickback or wheel breakage.
- b) Do not position your body in line with and behind the rotating wheel.** When the wheel, at the point of operation, is moving away from your body, the possible kickback may propel the spinning wheel and the power tool directly at you.
- c) When wheel is binding or when interrupting a cut for any reason, switch off the power tool and hold the power tool motionless until the wheel comes to a complete stop. Never attempt to remove the cut-off wheel from the cut while the wheel is in motion otherwise kickback may occur.** Investigate and take corrective action to eliminate the cause of wheel binding.
- d) Do not restart the cutting operation in the workpiece. Let the wheel reach full speed and carefully reenter the cut.** The wheel may bind, walk up or kickback if the power tool is restarted in the workpiece.
- e) Support panels or any oversized workpiece to minimize the risk of wheel pinching and kickback.** Large workpieces tend to sag under their own weight. Supports must be placed under the workpiece near the line of cut and near the edge of the workpiece on both sides of the wheel.
- f) Use extra caution when making a "pocket cut" into existing walls or other blind areas.** The protruding wheel may cut gas or water pipes, electrical wiring or objects that can cause kickback.

ADDITIONAL SAFETY RULES FOR YOUR ANGLE GRINDERS

Remove the plug from the socket before carrying out any adjustment, servicing or maintenance.

1. Fully unwind cable drum extensions to avoid potential overheating.
2. When an extension cable is required, you must ensure it has the right ampere rating for your power tool and is in a safe electrical condition.
3. Ensure your mains supply voltage is the same as your tool rating plate voltage.
4. Always switch off before you put the angle grinder down.
5. Do not let anyone under 18 years operate this tool.
6. Rags, cloths, cord, string and the like should never be left around the work area.
7. If you are interrupted when operating the tool, complete the process and switch off before looking up.
8. Do not store materials or equipment above a machine in such a way that they could fall into it.
9. When the disc is installed, run it for at least one minute to ensure that it does not have a fault. It is always advisable to stay out of the line of the disc when testing or in general in use.

ANGLE GRINDER 2350W TTB283GRD

10. Do not use a disc marked with a lower RPM than that of the no load speed shown on the rating plate.
11. Use discs only of the prescribed diameter.
12. Do not use the angle grinder for buffing or polishing under any circumstances.
13. Never try to operate the angle grinder without the guard in place.
14. Do not secure the angle grinder in a vice or work bench and use it as a static grinder. It can lead to serious injury.
15. Never apply excessive pressure to the disc. It might shatter causing personal injury.
16. Ensure the workpiece to be ground or cut, is held tight in the vice or other clamping system.
17. Always use both handles and ensure a good handgrip on the grinder before proceeding with any work.
18. Make sure that the disc is not in contact with the work when you start the grinder.
19. Be careful not to damage the spindle or either of the disc flanges. Damage to these parts could result in disc breakage.
20. Only use good quality grinding and cut off discs. Cheap poor quality discs tend to glaze up which loads the motor and can damage it. Use discs for their designated purpose only. For instance, do not use cutting discs for grinding or metal wheels on masonry.
21. Watch out for flying sparks. When grinding, hold the tool at an angle of approximately 15° to 30° to the workpiece surface.
22. Let the disc do the grinding or cutting at a reasonable feed, as overloading will occur if too much pressure is applied and the disc slows resulting in inefficient cutting and possible damage to the motor.
23. When using the grinder, use safety equipment including safety goggles or shield, ear protection, dust mask and protective clothing including safety gloves.

Store the recommended accessories in a well-ventilated area. Never expose them to the rain or humidity.



WARNING! Some dust particles created by power sanding, sawing, grinding, drilling and other construction jobs contain chemicals known to cause cancer, birth defects or other reproductive harm. Some examples of these chemicals are:

Lead from lead-based paints.

Crystalline silica from bricks and cement and other masonry products.

Arsenic and chromium from chemically treated timber.

Your risk from these exposures varies, depending upon how often you do this type of work. To reduce your exposure to these chemicals:

Work in a well ventilated area.

Work with approved safety equipment, such as those dust masks that specially designed to filter out microscopic particles and use the dust extraction facility at all time.

VIBRATION

The European Physical Agents (Vibration) Directive has been brought in to help reduce hand arm vibration syndrome injuries to power tool users. The directive requires power tool manufacturers and suppliers to provide indicative vibration test results to enable users to make informed decisions as to the period of time a power tool can be used safely on a daily basis and the choice of tool.

Further Advice can be found at www.hse.gov.uk

Vibration total values (triax vector sum) determined according to EN 60745:	
Grinding	Vibration for angle grinding $a_{h, AG} = 9.947m/s^2$
	Uncertainty $K = 1.5m/s^2$

The declared vibration emission value should be used as a minimum level and should be used with the current guidance on vibration.

Calculating the actual period of the actual period off use can be difficult and the HSE website has further information.

The declared vibration emission been measured in accordance with a standardised test stated above and may be used to compare one tool with another.

The declared vibration emission value may also be used in a preliminary assessment of exposure.



Warning: The vibration emission value during actual use of the power tool can differ from the declared value depending on the ways in which the tool is used dependant on the following examples and other variations on how the tool is used:

How the tool is used and the materials being ground or cut.

The tool being in good condition and well maintained

The use the correct accessory for the tool and ensuring it is sharp and in good condition.

The tightness of the grip on the handles.

And the tool is being used as intended by its design and these instructions.

This tool may cause hand-arm vibration syndrome if its use is not adequately managed



Warning: identify safety measures to protect the operator that are based on an estimation of exposure in the actual conditions of use (taking account of all parts of the operating cycle such as the times when the tool is switched off and when it is running idle in addition to the trigger time). Note The use of other tools will reduce the users' total working period on this tool.

Helping to minimise your vibration exposure risk.

Maintain this tool in accordance with these instructions and keep well lubricated (where appropriate)

Avoid using tools in temperatures of 10°C or less

Plan your work schedule to spread any high vibration tool use across a number of days.

Health Surveillance

All employees should be part of an employer's health surveillance scheme to help identify any vibration related diseases at an early stage, prevent disease progression and help employees stay in work.

ANGLE GRINDER 2350W TTB283GRD

Double insulation: 

The tool is double insulated. This means that all the external metal parts are electrically insulated from the mains power supply. This is done by placing insulation barriers between the electrical and mechanical components making it unnecessary for the tool to be earthed.

Important note:

Be sure the supply is the same as the voltage given on the rating plate. The tool is fitted with a two-core cable and plug.

Remove the mains plug from socket before carrying out any adjustment or servicing.

SYMBOLS



To reduce the risk of injury, user must read instruction manual



Warning



Waste electrical products should not be disposed of with household waste. Please recycle where facilities exist. Check with your Local Authority or retailer for recycling advice.



Wear ear protection



Wear eye protection



Wear dust mask



Double insulation



Conformity to CE directive

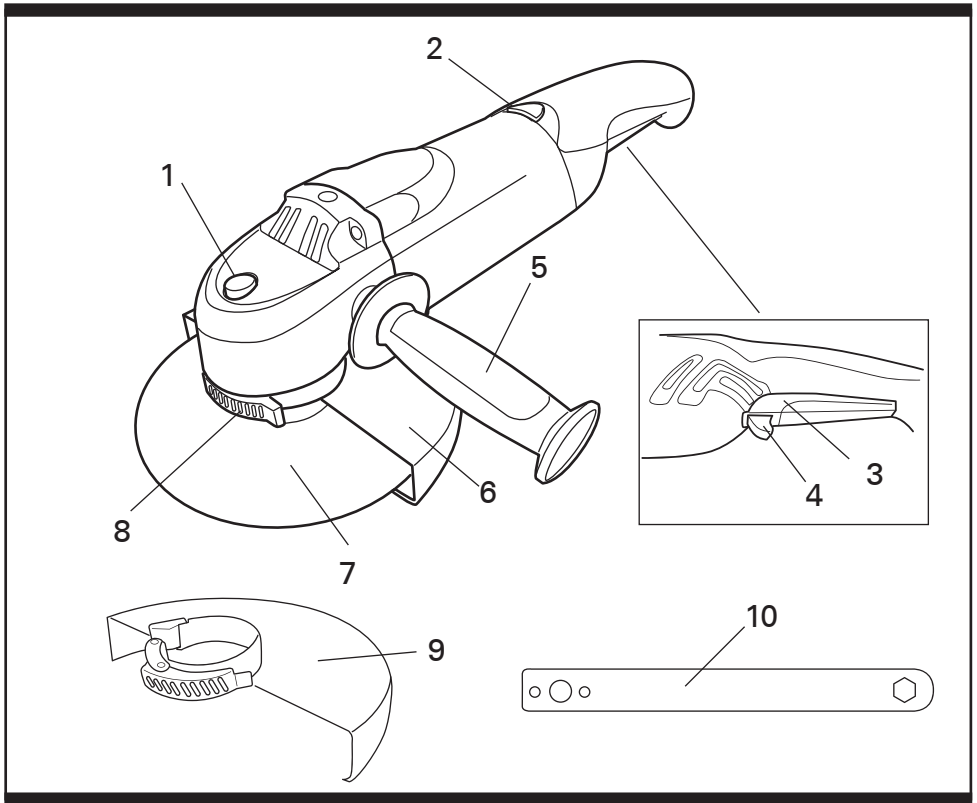

1 Spindle locking button

2 Lock button for rotating handle

3 Double action on/off switch

4 Lock-off catch

5 Auxiliary handle

6 Cutting guard

7 Cutting disc

8 Guard release lever

9 Grinding guard

10 Spanner

ANGLE GRINDER 2350W TTB283GRD

TECHNICAL DATA

Voltage:	230-240V~ 50Hz
Input power:	2350W
Rated speed:	6200/min
Maximum disc diameter:	230mm
Spindle size:	M14
Disc bore diameter:	22.2mm
Protection class:	II
Machine weight:	6.2kg

NOISE DATA

A weighted sound pressure	100.8dB(A) / KpA: 3dB(A)
A weighted sound power	111.8dB(A) / KwA: 3dB(A)
Wear ear protection when sound pressure is over	80dB

ACCESSORIES

Auxiliary handle	1pc
Spanner	1pc
230mm cutting guard	1pc
230mm grinding guard	1pc
230mm masonry grinding disc	1pc

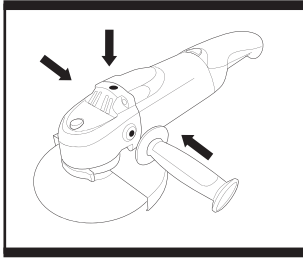

Fig. 1

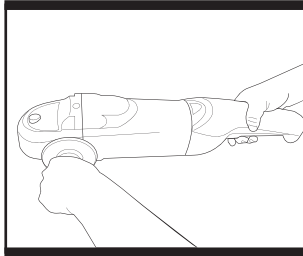

Fig. 2

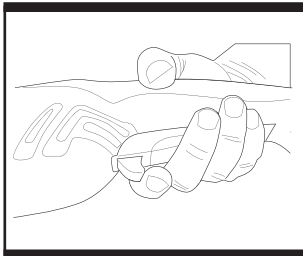

Fig. 3

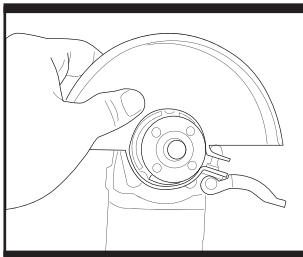

Fig. 4

OPERATIONS INSTRUCTIONS



Note: Before using the tool, read the instruction book carefully.

INTENDED USE

This angle grinder shall be used for grinding or cutting metal or stones or similar materials.

Other uses for the tool will lead to the damage of the tool and a series of dangers to the operator. This tool is intended for DIY home use, or occasional professional use.

1. FITTING THE AUXILIARY HANDLE (Fig. 1)

There are three mounting points for the auxiliary handle (5) at both side and on the top. Attach the handle (5) in the position that provide the safest and most comfortable control of your grinder. Always use the auxiliary handle.

2. HAND GRIP AREAS (Fig. 2)

Always hold your angle grinder firmly with both hands when operating.

3. DOUBLE ACTION ON/OFF SWITCH (Fig. 3)

To start your angle grinder, push the lock-off catch forward and pull on the trigger switch(3). To switch off, release the trigger switch(3).

4. REPLACING THE GUARD (Fig. 4 & Fig 5)

Depending on whether your operation is cutting or grinding, select the correct disc guard. This tool is supplied with both grinding and cutting guards. Please make ensure you are using the correct guard for the task. Failure to use the cutting guard(6) for cutting operations could result in injury. This guard has been specifically designed to offer extra protection in the rare event of disc or workpiece failure.

Use of the grinding guard(9) offers extra versatility in confined spaces but must only be used for grinding.

To remove the guard, pull up the release lever(8), then turn the guard to the position as Fig. 4 (making sure the bulge on the guard ring matching the notch), and remove it.

To install the new guard, insert the guard to the head of the machine from position as Fig. 4, making sure the bulge on the guard ring matching the notch, then turn the guard to the appropriate position, where it will deflect hot sparks away from the operator and offer the maximum protection for the operator. Pull down the lever to clamp it.

NOTE: Make sure that the guard fixing bolt is tight enough so that the disc guard cannot be moved, tighten the fixing nut using a suitable spanner if necessary.

5. DISC FITTING (Fig. 6 & Fig. 7 & Fig. 8)

The inner flange is located over the spindle and on the two spindle flats. Locate the disc onto the inner flange and then the outer flange screwed onto the spindle. Fit the threaded outer flange making sure it is facing in the correct direction for the type of disc fitted. For cutting disc, the flange is fitted with the raised portion facing away from the disc (Fig. 6b). For grinding disc, fit the threaded outer flange with the raised portion facing the disc (Fig. 6a).

Press the spindle lock button (1) and rotate the spindle until it locks, then firmly tighten the outer flange using the provided spanner to clamp the disc. The pins on the spanner locate in the holes on the outer flange (Fig. 7). Check the disc rotates freely and is securely clamped. Make no load test run for 20 seconds to check disc vibration and disc run out. To remove a disc, reverse these instructions.

 **Warning:** the spindle lock button must only be used when changing a disc. Never press when the disc is rotating! Always ensure your disc is securely clamped.

6. ROTATING THE HANDLE (Fig. 9)

To best suit the different working positions, your angle grinder is equipped with a rotating handle. Press the lock button for the rotating handle and you can rotate the handle 90° to left or right. Then release the lock button. A click will be heard when the handle is fully locked in place.

 **WARNING!** Make sure that the handle is safely locked in one position before starting any work.

WORKING HINTS FOR YOUR ANGLE GRINDER

Always start at no load to achieve maximum speed then start working.

Do not force the disc to work faster, reducing the disc's moving speed means longer working time.

Always work with a 10-20 angle between disc and work-piece. Larger angles will cut ridges into the work-piece and affect the surface finish. Move the angle grinder across and back and forth over the work-piece.

When using a cutting disc never change the cutting angle otherwise you will stall the disc and angle grinder motor or break the disc. When cutting, only cut in the opposite direction to the disc rotation. If you cut in the same direction as the disc rotation the disc may push itself out of the cut slot.

Always ensure the work-piece is firmly held or clamped to prevent movement.

For cutting, always work with the wheel guard for cutting.

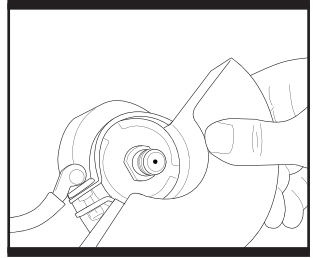

Fig. 5

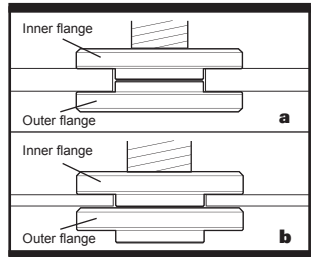

Fig. 6

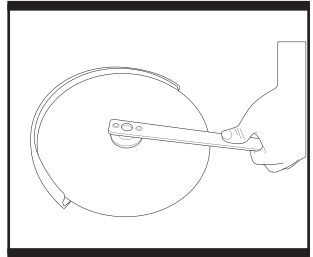

Fig. 7

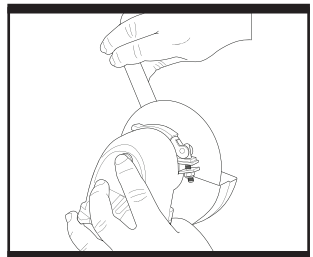

Fig. 8

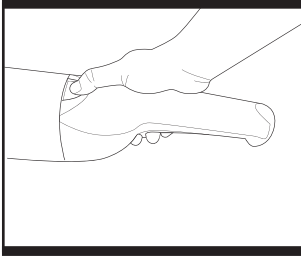

Fig. 9

MAINTENANCE

Remove the plug from the socket before carrying out any adjustment, servicing or maintenance.

Your power tool requires no additional lubrication or maintenance. There are no user serviceable parts in your power tool. Never use water or chemical cleaners to clean your power tool. Wipe clean with a dry cloth. Always store your power tool in a dry place. Keep the motor ventilation slots clean. Keep all working controls free of dust.

Occasionally you may see sparks through the ventilation slots. This is normal.

If the supply cord is damaged, it must be replaced by the manufacturer, its service agent or similarly qualified persons in order to avoid a hazard.

Always handle abrasives with great care, they are easily damaged. Examine all abrasive products for damage or defects before mounting. Use good quality abrasive products and keep them in good condition during their life. Avoid continuous use of abrasive products. Store them in a box and keep in a dry place.

ENVIRONMENTAL PROTECTION



Waste electrical products should not be disposed of with household waste. Please recycle where facilities exist. Check with your Local Authority or retailer for recycling advice. For further information visit www.recyclenore.co.uk

UK PLUG REPLACEMENT

The fuse in the main plug of your power tool should always be replaced with one of identical rating.

Check the voltage given on your power tool matches the supply voltage.

The power tool is supplied with a fitted plug, however if you should need to fit a new plug follows the instruction below.

IMPORTANT

The wire in the mains lead are coloured in accordance with the following code:

Blue ---Neutral

Brown ---Live

The wire that is coloured **blue** must be connected to the terminal that is marked with the letter **N**. The wire that is coloured **brown** must be connected to the terminal that is marked with the letter **L**.

A 13 AMP (BS1363 or BS1363/A) plug must be used and a 13 AMP fuse must be fitted.

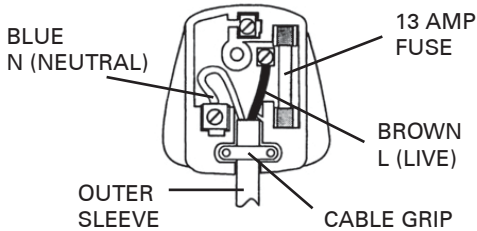

TITAN®

Declaration of Conformity

We, Importer
Titan Power Tools (UK) Ltd
Trade house, Mead Avenue, BA22 8RT

Declare that the product:
Designation: ANGLE GRINDER 2350W
Model: TTB283GRD

Complies with the following Directives:
2004/108/EC Electromagnetic Compatibility Directive,
2006/42/EC Machinery Directive
2006/95/EC Low Voltage Directive,
2002/95/EC Restrictions of the Use of Certain Hazardous Substances in Electrical and Electronic Equipment
2002/96/EC and 2003/108/EC Waste Electrical and Electronic Equipment (WEEE),

Standards and technical specifications referred to:

EN 60745-1: 2009
EN 60745-2-3: 2007+A11: 2009
EN 55014-1: 2006
EN 55014-2:1997+A1: 2001+A2: 2008
EN 61000-3-2: 2006
EN 61000-3-3: 2008

Authorised signatory and technical file holder

Date: 07/07/2010

Signature: _____

Name / title: Peter Harries / Quality Manager

Titan Power Tools (UK)Ltd. Trade House , Mead Avenue ,BA22 8RT



ANGLE GRINDER 2350W TTB283GRD