

KOHLER® Command PRO®

7-14 hp Engines



KOHLER®

KOHLER[®] |

PERFORMANCE
ENGINEERING

Engineered to perform in the harshest environments, Quad-Clean™ all-season four-stage cyclonic air filter—a standard on Command PRO® 7-14 hp engines—protects the engine from airborne contaminants that can easily clog traditional air filters. Since the Quad-Clean air filter assembly isn't any heavier or bulkier than a conventional air filter, the engine's ergonomics and fuel economy aren't compromised.

How does Quad-Clean™ work?



- 1 The mesh screen at the air intake port provides first step of protection.
- 2 As air enters the air-cleaning chamber, it is circulated in a rapid, cyclonic motion that forces the large contaminants out of the engine.
- 3 The reusable, environmentally friendly foam pre-cleaner traps midsize contaminants.
- 4 Dual-metal mesh enforced, the pleated air filter traps the finest contaminants ensuring that only clean air enters the engine for maximum power and life of the engine.

Emissions:

Meets regulatory requirements around the world, including CARB Tier 3, EPA Phase III, EU Stage 2, RFI/EMC EU Noise and EU Safety.

Service:

Backed by more than 13,000 dealers and distributors worldwide.

Warranty:

Three-year limited warranty covering all commercial applications globally.

What it takes to be a PRO.

The KOHLER® Command PRO® insignia is reserved for products that offer best-in-class features like our heavy-duty air cleaner, forged-steel crankshafts, advanced ignition module and cast-iron cylinder bore liner, making the Command PRO family of engines the standard for professional grade power and performance.



Industry Standard Dimensions and Interchangability.

Provides flexibility to power any new equipment or repower existing equipment without modifications.



Dependable All-Season Operation.

In colder months the Quad-Clean™ air filter can be reconfigured, without tools and in a matter of seconds, to recycle engine heat. Along with advanced electronic ignition, automatic compression release and dual ball bearings, the Command PRO® engine provides effortless starts in all weather and conditions.



Designed for Quiet Operation.

A fully integrated system, including a silenced air intake, sound-deadening muffler and alloy crankcase, creates a smoother, quieter performance.



Engineered for Enhanced Durability.

KOHLER® Command PRO® engines feature forged-steel crankshafts, cast-iron cylinder bores, tough Stellite®-faced exhaust valves with Tuffride®-coated stems and dual main ball bearings for maximum side-load characteristics. Oil Sentry™ protects engine in low oil conditions by automatically shutting the engine down.



Efficient Ignition and Fuel System.

The KOHLER advanced ignition system reduces fuel consumption, while the large-capacity fuel tank allows for longer runs between fill-ups. Combined, these two features will save you money and time.

7-hp engines
(CH270)

TOP VIEW

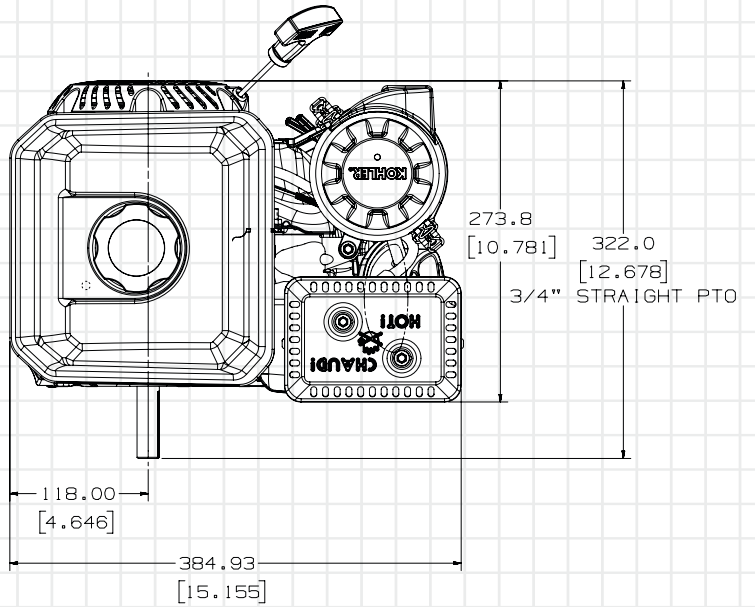

PTO VIEW

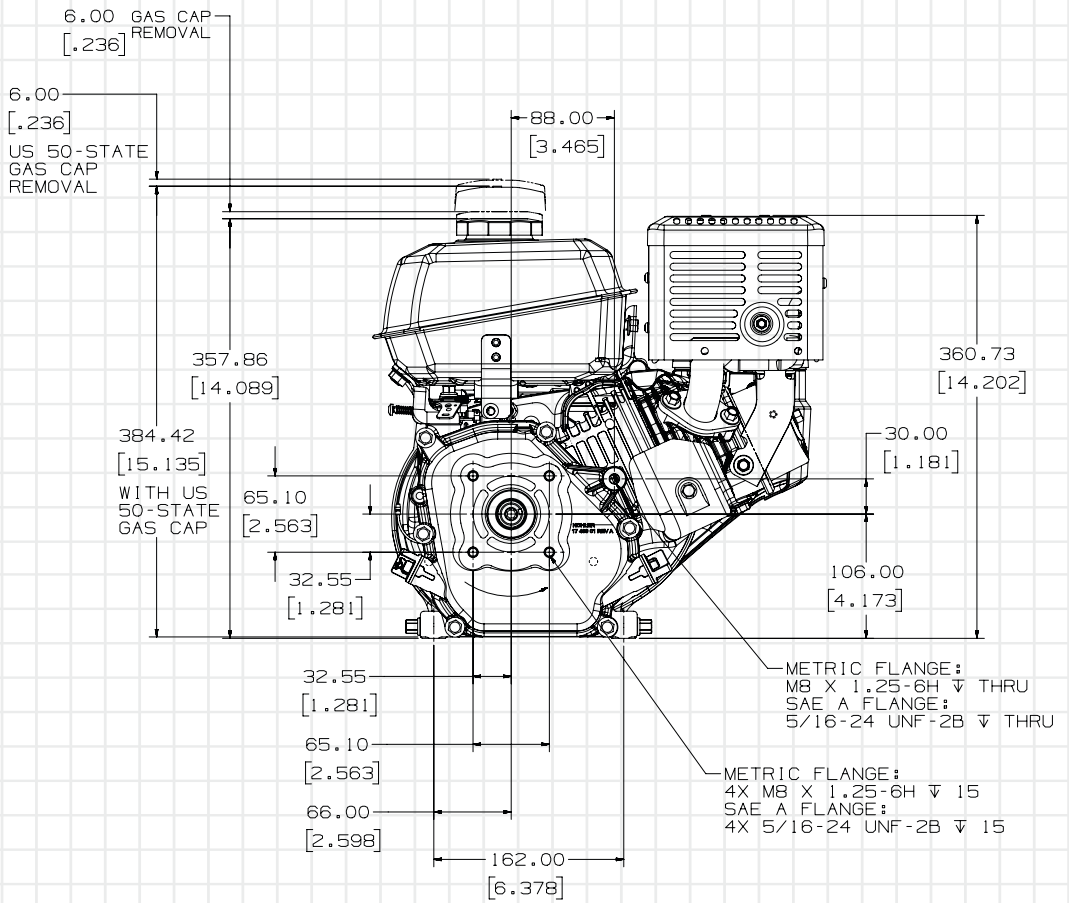

7-hp engines (CH270)

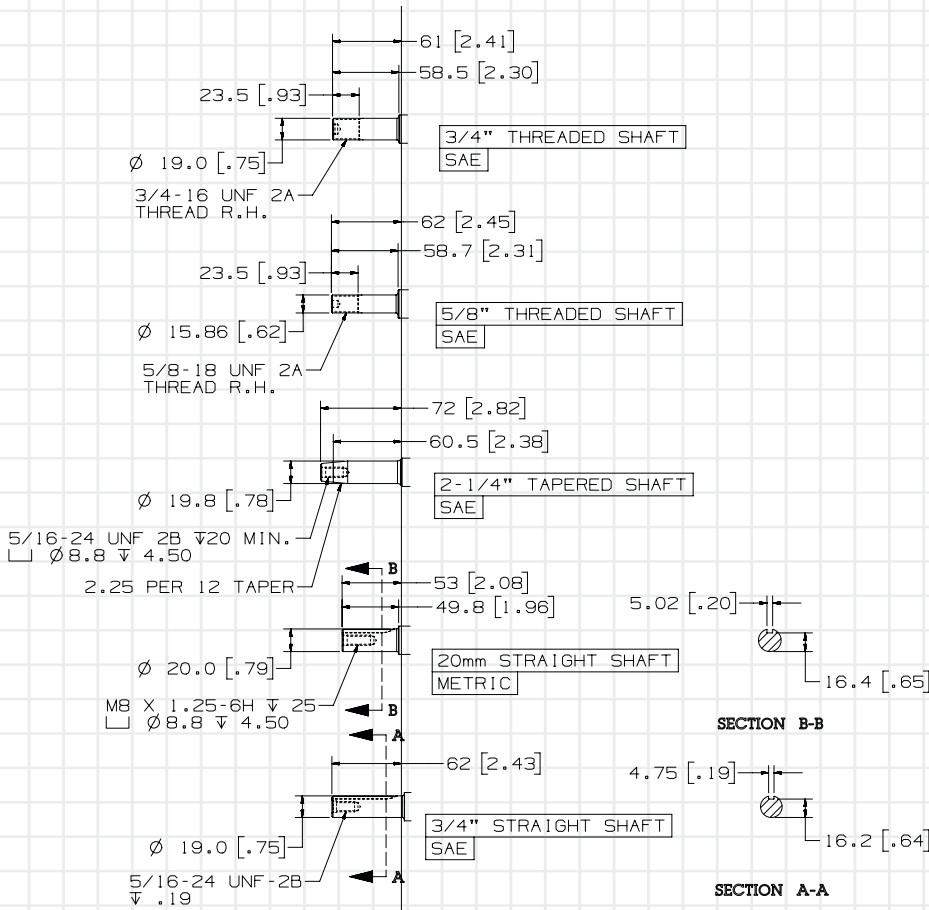

SHAFT VARIATIONS

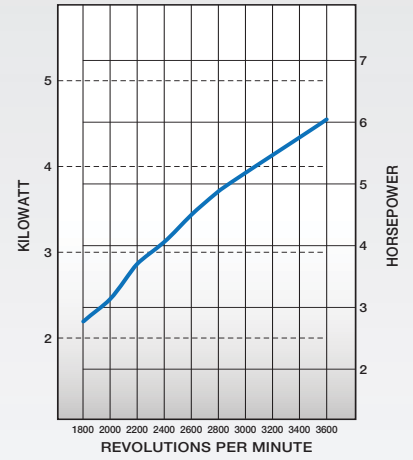

Net Power

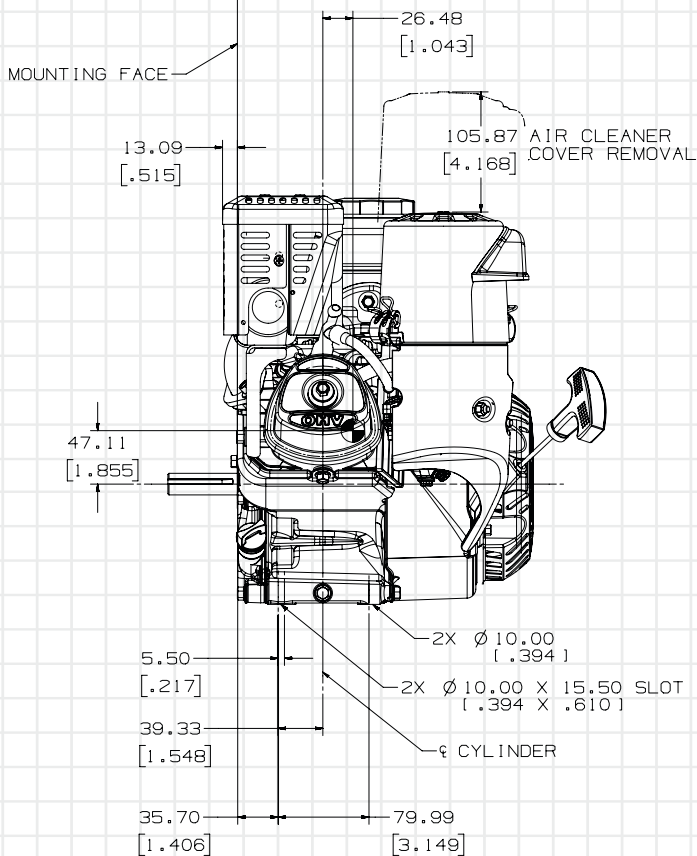

VALVE COVER VIEW

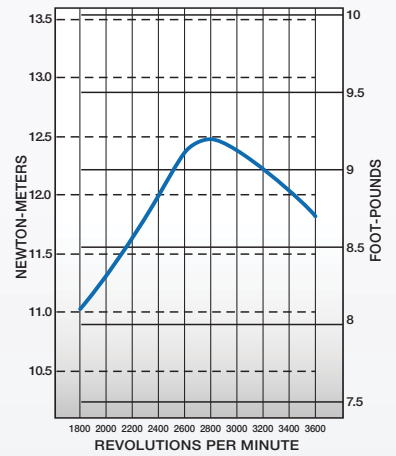

Net Torque

9.5-hp engines
(CH395)

TOP VIEW

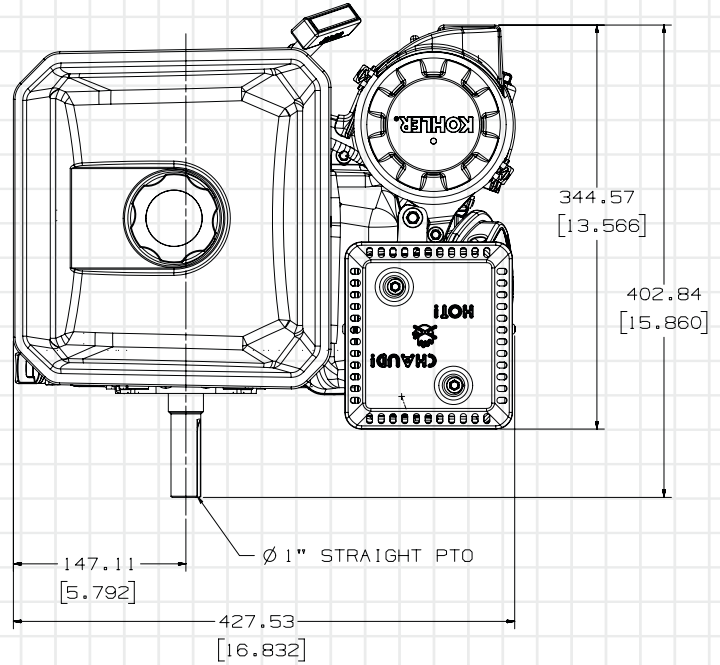

PTO VIEW

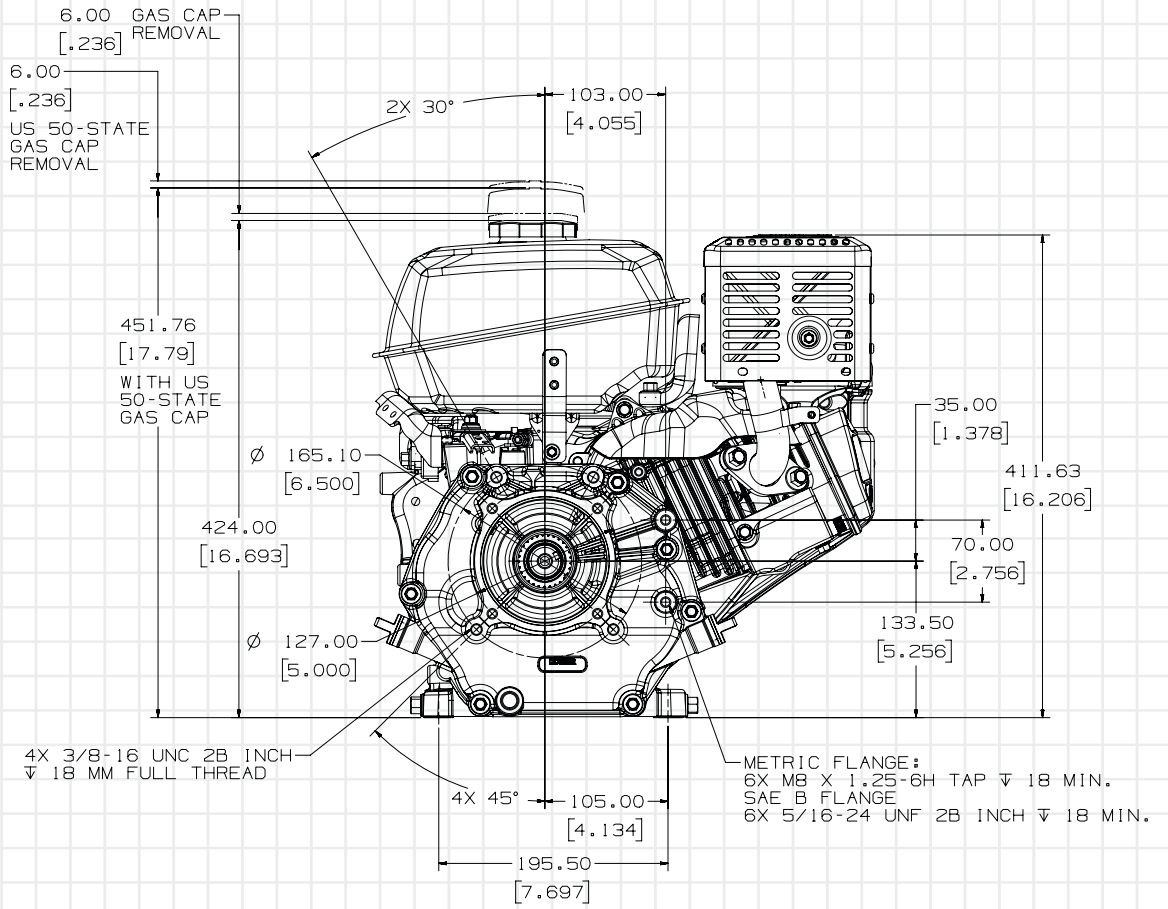

9.5-hp engines (CH395)

SHAFT VARIATIONS



VALVE COVER VIEW

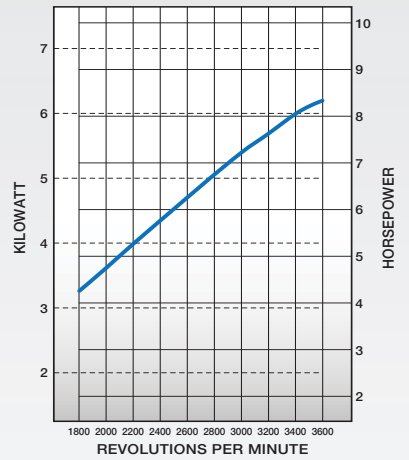
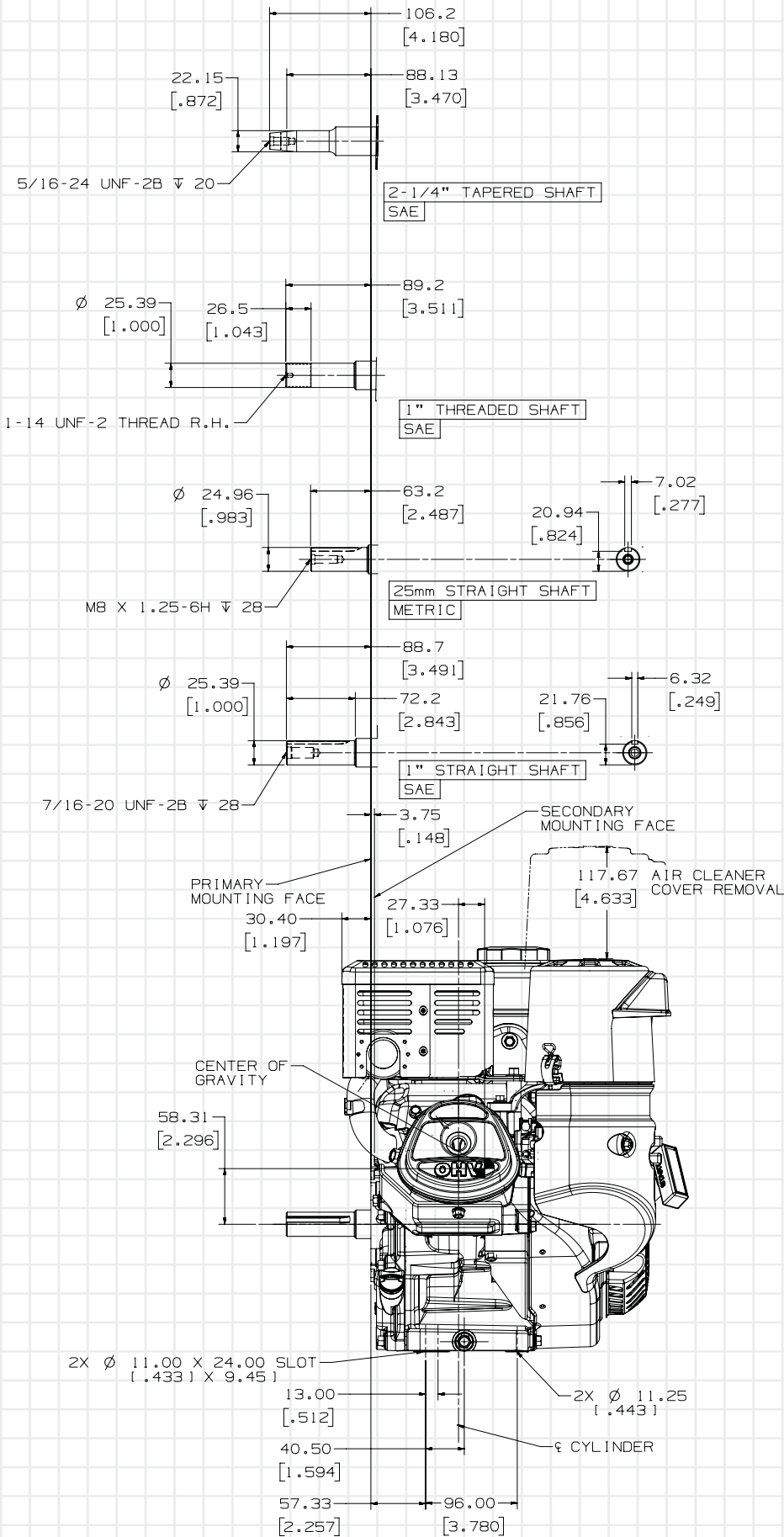

Net Power

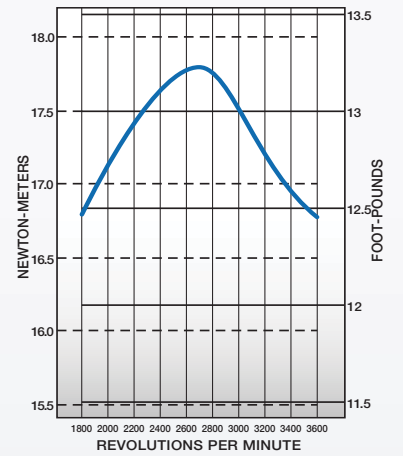

Net Torque

14-hp engines (CH440)

KOHLER® COMMAND PRO® ENGINE ARCHITECTURE

TOP VIEW ▼

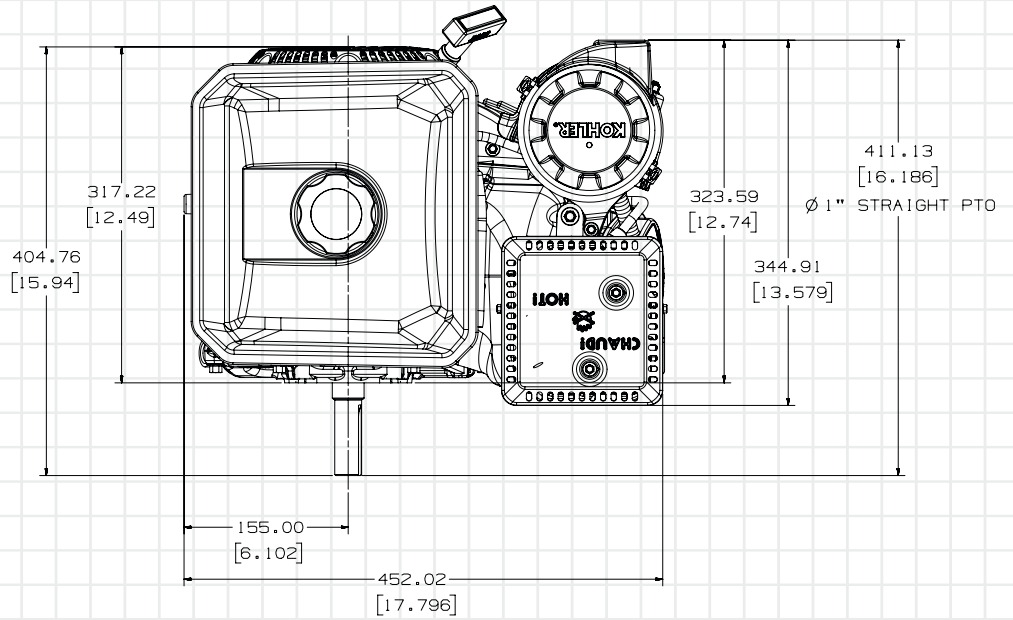

PTO VIEW ▼

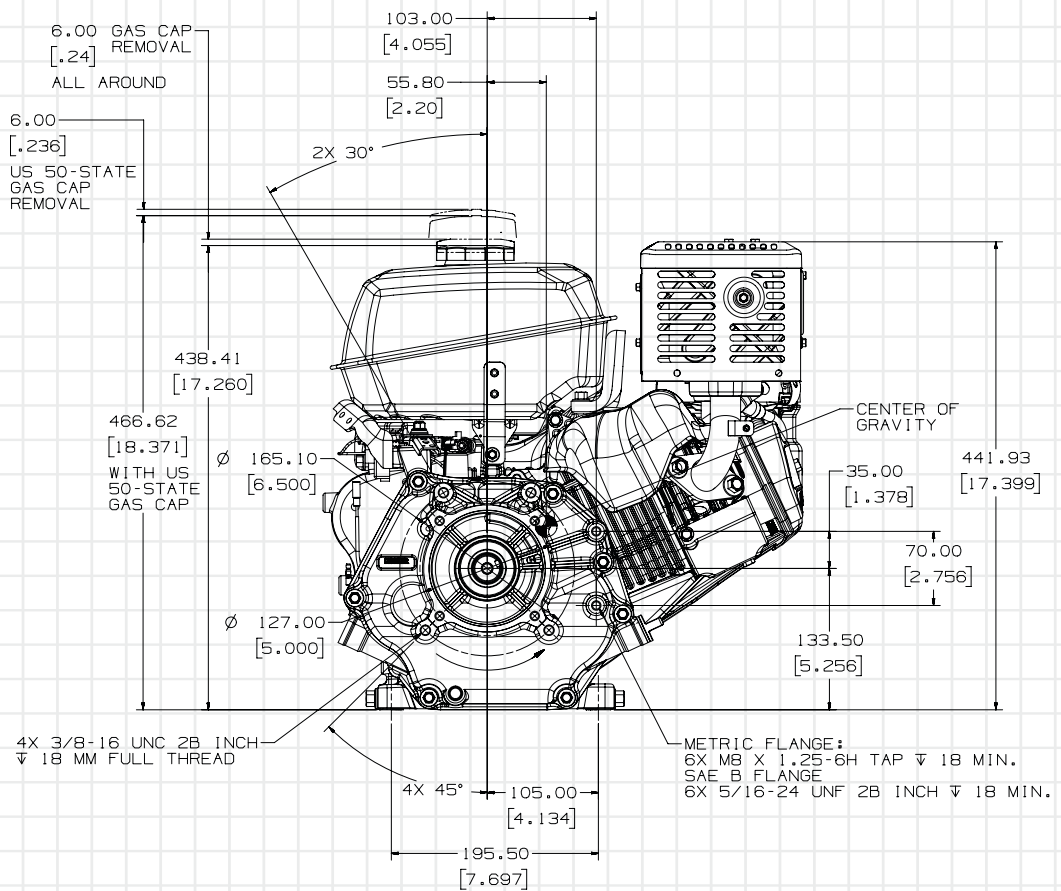

14-hp engines (CH440)

SHAFT VARIATIONS



VALVE COVER VIEW

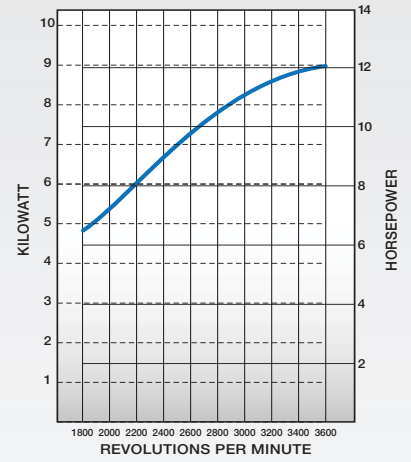
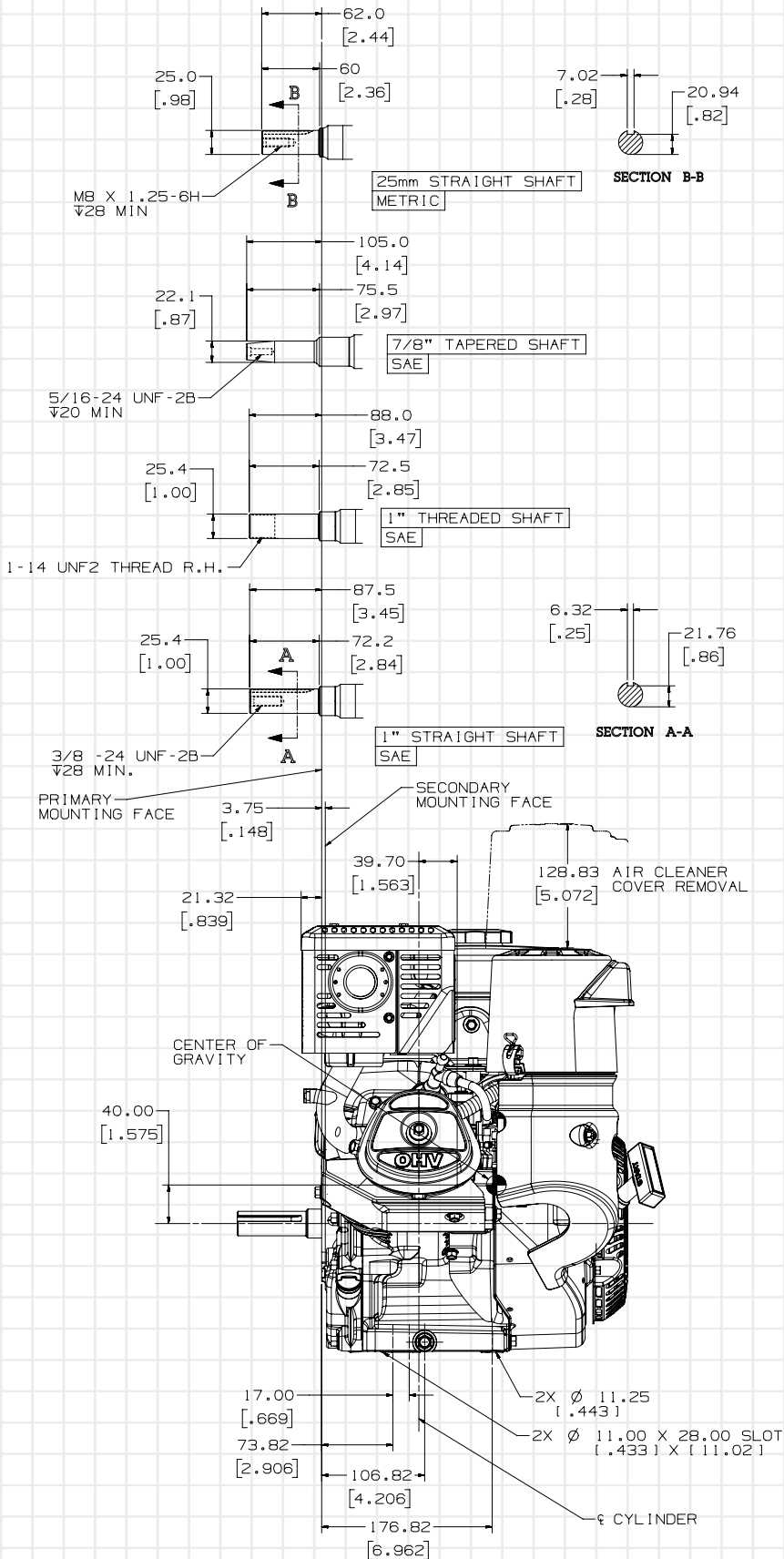

Net Power

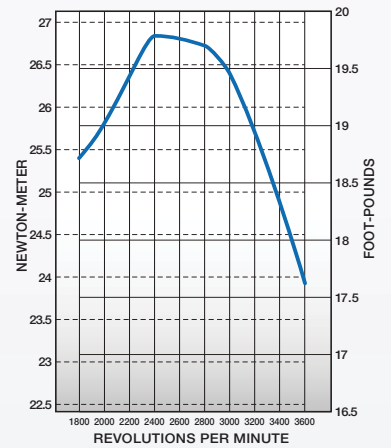

Net Torque

KOHLER® Command PRO® Model Specifications

Engine Type		Four-cycle, single-cylinder, overhead valve, air-cooled, gasoline, horizontal-shaft, aluminum head and crankcase with cast-iron cylinder liner		
Model		CH270	CH395	CH440
*Gross Power @ 3600 rpm	Maximum hp (kW)	7 (5.2)	9.5 (7.1)	14 (10.5)
*Net Power @ 3600 rpm	Maximum hp (kW)	6 (4.5)	8.5 (6.4)	12.1 (9.0)
Displacement	cu in (cc)	12.7 (208)	16.9 (277)	24.7 (429)
Bore	in (mm)	2.8 (70)	3.1 (78)	3.5 (89)
Stroke	in (mm)	2.1 (54)	2.3 (58)	2.7 (69)
Peak Torque @ rpm	ft lbs (Nm)	9.2 (12.4) @ 2800	13.2 (17.8) @ 2600	19.8 (26.8) @ 2600
Compression Ratio		8.5:1		8:1
Dry Weight (Recoil Start)	lbs (kg)	38.7 (17.5)	61.5 (27.9)	72.8 (33.0)
Oil Capacity	U.S. qt (L)	0.6 (0.6)	1.4 (1.3)	
Fuel Capacity	U.S. qt (L)	4.2 (4.0)	7.4 (7.0)	
Lubrication		Splash		
**Dimensions L x W x H	in (mm)	12.7 x 15.2 x 14.2 (323 x 385 x 361)	15.9 x 16.8 x 16.2 (403 x 428 x 424)	16.2 x 17.8 x 17.4 (411 x 452 x 442)
Crankshaft Height	in (mm)	4.2 (106.0)	5.3 (133.5)	

*Horsepower ratings meets Society of Automotive Engineers Small Engine Test Code J1940. Actual engine horsepower is lower and affected by, but not limited to, accessories (air cleaner, exhaust, charging, cooling, fuel pump, etc.), application, engine speed and ambient operating conditions (temperature, humidity and altitude). For more information, contact Kohler Co. Engine Engineering. Kohler reserves the right to change product specifications, designs and equipment without notice and without incurring obligation.

**Engine measurements based on a base engine without electric start.

Standard Features

- Quad-Clean™ heavy-duty cyclonic air cleaner
- Built-in warm-air system for operating in cold weather
- OHV slant cylinder
- Cast-iron cylinder liner
- Large-capacity metal fuel tank
- Three fuel filters: fill neck, in-tank and carburetor inlet
- Electronic ignition
- Large-capacity muffler with heat shield and spark arrestor
- EPA II emission-certified
- Increased displacement
- Balance shaft (14 hp)
- Dual ball bearings
- Steel forged crankshaft
- Dual oil fills and drains
- Automatic low-oil engine shutdown system
- Stellite®-faced exhaust valve
- Chrome-plated metal fuel tank cap
- Water trap to separate moisture in fuel
- Swirl-induction combustion chamber
- Easy-access throttle, choke and shutoff
- Automatic compression release
- Mechanical governor
- Sound-deadening alloy crankcase
- Carburetor bowl drain
- High-inertial flywheel
- Silenced air intake
- Indexable easy-pull recoil starter

Popular Factory Options

- 2:1 reduction
- 12-volt starter
- 3-, 10- or 18-amp (9.5- and 14-hp) charging
- Crankshaft/PTO variations
- Low-profile air cleaner and muffler (generator)
- No load idle solenoid for welders
- CARB Tier 3 compliance
- EEC and Canadian RFI Standards
- EU emissions and noise compliance
- EPA Phase III compliance
- Balance shaft 9.5 hp
- Exhaust deflector
- In-line fuel filter
- Remote throttle
- Remote choke

For more information, contact your KOHLER source of supply, or call toll-free in the U.S. and Canada 800-544-2444.

Kohler Co., Kohler, Wisconsin 53044 Tel 920-457-4441 Fax 920-459-1570

KohlerEngines.com

© 2010 by Kohler Co. All rights reserved.

KOHLER®, Command PRO®, Quad-Clean™ are trademarks of Kohler Co.

KOHLER®

Relentless Power.
Legendary Performance.

Printed in U.S.A. E-2141-A 10/10