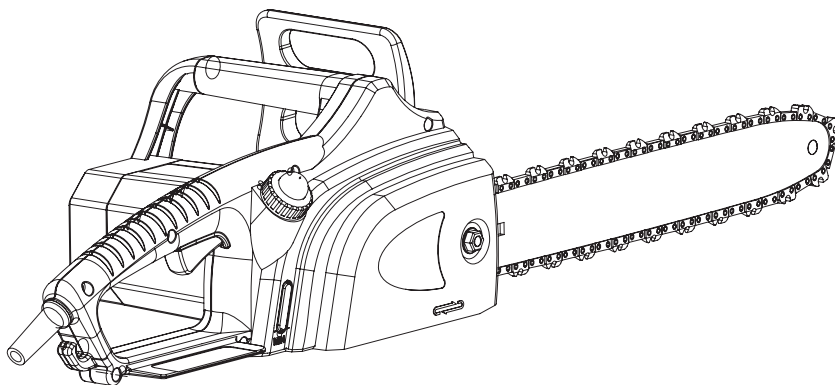


# TITAN®



**24** month  
Manufacturer's  
Warranty

## SAFETY AND OPERATING MANUAL

Original instructions

ISSUE DATE: REV5-NOV12

### CHAIN SAW 2000W TTB355CHN

# TITAN®

**Congratulations on your purchase of a TITAN power tool from Titan Power Tools (UK) Ltd. We want you to continue getting the best performance from it so this handbook includes information on safety, handling and care. Please retain this handbook in case you need to refer to any of the information in the future.**

**Your TITAN power tool comes with a 24-month guarantee, so should it develop a fault within this period contact your retailer.**

## **GUARANTEE**

This **TITAN** product carries a guarantee of 24 months. If your product develops a fault within this period, you should, in the first instance contact the retailer where the item was purchased.

This guarantee specifically excludes losses caused due to:

- Fair wear and tear
- Misuse or abuse
- Lack of routine maintenance
- Failure of consumable items (such as batteries)
- Accidental damage
- Cosmetic damage
- Failure to follow manufacturer's guidelines
- Loss of use of the goods

This guarantee does not affect your statutory rights. This guarantee is only valid in the UK.

For any enquiries relating to the guarantee please refer to your retailer.

## GENERAL SAFETY INSTRUCTIONS



**WARNING! Read all safety warnings and all instructions.** Failure to follow the warnings and instructions may result in electric shock, fire and/or serious injury.



**Save all warnings and instructions for future reference.**

The term "power tool" in the warnings refers to your mains-operated (corded) power tool or battery-operated (cordless) power tool.

### SAVE THESE INSTRUCTIONS

#### 1. Work area safety

- a. Keep work area clean and well lit.** Cluttered or dark areas invite accidents.
- b. Do not operate power tools in explosive atmospheres, such as in the presence of flammable liquids, gases or dust.** Power tools create sparks which may ignite the dust or fumes.
- c. Keep children and bystanders away while operating a power tool.** Distractions can cause you to lose control.

#### 2. Electrical safety

- a. Power tool plugs must match the outlet. Never modify the plug in any way. Do not use any adapter plugs with earthed (grounded) power tools.** Unmodified plugs and matching outlets will reduce risk of electric shock.
- b. Avoid body contact with earthed or grounded surfaces, such as pipes, radiators, ranges and refrigerators.** There is an increased risk of electric shock if your body is earthed or grounded.
- c. Do not expose power tools to rain or wet conditions.** Water entering a power tool will increase the risk of electric shock.
- d. Do not abuse the cord. Never use the cord for carrying, pulling or unplugging the power tool. Keep cord away from heat, oil, sharp edges or moving parts.** Damaged or entangled cords increase the risk of electric shock.
- e. When operating a power tool outdoors, use an extension cord suitable for outdoor use.** Use of a cord suitable for outdoor use reduces the risk of electric shock.
- f. If operating a power tool in a damp location is unavoidable, use a residual current device (RCD) protected supply.** Use of an RCD reduces the risk of electric shock.

#### 3. Personal safety

- a. Stay alert, watch what you are doing and use common sense when operating a power tool.**  
**Do not use a power tool while you are tired or under the influence of drugs, alcohol or medication.** A moment of inattention while operating power tools may result in serious personal injury.
- b. Use personal protective equipment. Always wear eye protection.** Protective equipment such as dust mask, non-skid safety shoes, hard hat, or hearing protection used for appropriate conditions will reduce personal injuries.
- c. Prevent unintentional starting. Ensure the switch is in the off-position before connecting to power source and/or battery pack, picking up or carrying the tool.** Carrying power tools with your finger on the switch or energising power tools that have the switch on invites accidents.
- d. Remove any adjusting key or wrench before turning the power tool on. A**

# CHAIN SAW 2000W TTB355CHN

wrench or a key left attached to a rotating part of the power tool may result in personal injury.

**e. Do not overreach. Keep proper footing and balance at all times.** This enables better control of the power tool in unexpected situations.

**f. Dress properly. Do not wear loose clothing or jewellery. Keep your hair, clothing and gloves away from moving parts.** Loose clothes, jewellery or long hair can be caught in moving parts.

**g. If devices are provided for the connection of dust extraction and collection facilities, ensure these are connected and properly used.** Use of dust collection can reduce dust-related hazards.

#### 4. Power tool use and care

**a. Do not force the power tool. Use the correct power tool for your application.** The correct power tool will do the job better and safer at the rate for which it was designed.

**b. Do not use the power tool if the switch does not turn it on and off.** Any power tool that cannot be controlled with the switch is dangerous and must be repaired.

**c. Disconnect the plug from the power source and/or the battery pack from the power tool before making any adjustments, changing accessories, or storing power tools.** Such preventive safety measures reduce the risk of starting the power tool accidentally.

**d. Store idle power tools out of the reach of children and do not allow persons unfamiliar with the power tool or these instructions to operate the power tool.** Power tools are dangerous in the hands of untrained users.

**e. Maintain power tools. Check for misalignment or binding of moving parts, breakage of parts and any other condition that may affect the power tool's operation. If damaged, have the power tool repaired before use.** Many accidents are caused by poorly maintained power tools.

**f. Keep cutting tools sharp and clean.** Properly maintained cutting tools with sharp cutting edges are less likely to bind and are easier to control.

**g. Use the power tool, accessories and tool bits etc. in accordance with these instructions, taking into account the working conditions and the work to be performed.** Use of the power tool for operations different from those intended could result in a hazardous situation.

**h. Keep handle dry, clean and free from oil and grease.** Slippery handles do not allow for safe handling and control of the tool in unexpected situations.

#### 5. Service

**a. Have your power tool serviced by a qualified repair person using only identical replacement parts.** This will ensure that the safety of the power tool is maintained.

**b. If the replacement of the supply cord is necessary, this has to be done by the manufacturer or his agent in order to avoid a safety hazard.**



**WARNING!** This machine produces an electromagnetic field during operation. This field may under some circumstances interfere with active or passive medical implants. To reduce the risk of serious or fatal injury, we recommend persons with medical implants to consult their physician and the medical implant manufacturer before operating this machine.

## 6. ADDITIONAL SAFETY RULES FOR CHAIN SAW.

- a. Keep all parts of the body away from the saw chain when the chain saw is operating. Before you start the chain saw, make sure the saw chain is not contacting anything.** A moment of inattention while operating chain saws may cause entanglement of your clothing or body with the saw chain.
- b. Always hold the chain saw with your right hand on the rear handle and your left hand on the front handle.** Holding the chain saw with a reversed hand configuration increases the risk of personal injury and should never be done.
- c. Wear safety glasses and hearing protection. Further protective equipment for head, hands, legs and feet is recommended.** Adequate protective clothing will reduce personal injury by flying debris or accidental contact with the saw chain.
- d. Do not operate a chain saw in a tree.** Operation of a chain saw while up in a tree may result in personal injury.
- e. Always keep proper footing and operate the chain saw only when standing on fixed, asecur and level surface.** Slippery or unstable surfaces such as ladders may cause a loss of balance or control of the chain saw.
- f. When cutting a limb that is under tension be alert for spring back.** When the tension in the wood fibres is released the spring loaded limb may strike the operator and/or throw the chain saw out of control.
- g. Use extreme caution when cutting brush and saplings.** The slender material may catch the saw chain and be whipped toward you or pull you off balance.
- h. Carry the chain saw by the front handle with the chain saw switched off and away from your body. When transporting or storing the chain saw always fit the guide bar cover.** Proper handling of the chain saw will reduce the likelihood of accidental contact with the moving saw chain.
- i. Follow instructions for lubricating, chain tensioning and changing accessories.**  
Improperly tensioned or lubricated chain may either break or increase the chance for kickback.
- j. Keep handles dry, clean, and free from oil and grease.** Greasy, oily handles are slippery causing loss of control.
- k. Cut wood only. Do not use chain saw for purposes not intended. For example: do not use chain saw for cutting plastic, masonry or non-wood building materials.** Use of the chain saw for operations different than intended could result in a hazardous situation.
- l. The appliance should be supplied via a Residual Current Device (RCD) with a tripping current of not more than 30mA.**
- m. The first time user should have practical instruction in the use of the chain saw and the protective equipment from an experienced.**

## 5. CAUSES and operator prevention of kickback:

- a.** Kickback may occur when the nose or tip of the guide bar touches an object, or when the wood closes in and pinches the saw chain in the cut.
- b.** Tip contact in some cases may cause a sudden reverse reaction, kicking the guide bar up and back towards the operator.
- c.** Pinching the saw chain along the top of the guide bar may push the guide bar rapidly back towards the operator.
- d.** Either of these reactions may cause you to lose control of the saw which could result in serious personal injury. Do not rely exclusively upon the safety devices built

# CHAIN SAW 2000W TTB355CHN

into your saw. As a chain saw user, you should take several steps to keep your cutting jobs free from accident or injury.

**e.** Kickback is the result of tool misuse and/or incorrect operating procedures or conditions and can be avoided by taking proper precautions as given below:

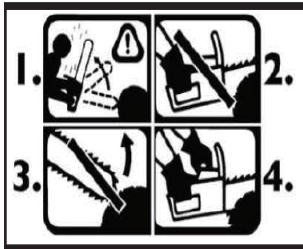
**- Maintain a firm grip, with thumbs and fingers encircling the chain saw handles, with both hands on the saw and position your body and arm to allow you to resist kickback forces.** Kickback forces can be controlled by the operator, if proper precautions are taken. Do not let go of the chain saw.

**- Do not overreach and do not cut above shoulder height.** This helps prevent unintended tip contact and enables better control of the chain saw in unexpected situations.

**- Only use replacement bars and chains specified by the manufacturer.**

Incorrect replacement bars and chains may cause chain breakage and/or kickback.

**- Follow the manufacturer's sharpening and maintenance instructions for the saw chain.** Decreasing the depth gauge height can lead to increased kickback.



**Fig. 1**

## 6. Important safety

### 1). How to read symbols. (See Fig. 1)


 **Warning!** Used to warn that an unsafe procedure should not be performed.

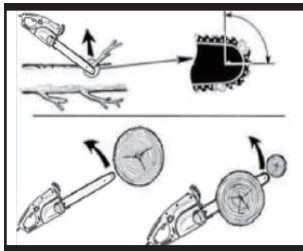
Image 1--- Beware of kickback.

Image 2--- Do not attempt to hold saw with one hand.

Image 3--- Avoid bar nose contact.


Image 4--- Hold saw properly with both hands. Never use the machine

with one hand: the chain brake does not work!



**Fig. 2a**

### 2). Danger! Beware of kickback!

 **Warning!** Kickback can lead to dangerous loss of control of the chain saw and result in serious or fatal injury to the saw operator or to anyone standing close by. Always be alert because rotational kickback and pinch kickback are major chain saw operational dangers and the leading cause of most accidents.

Beware of rotational kickback. (See Fig. 2a)

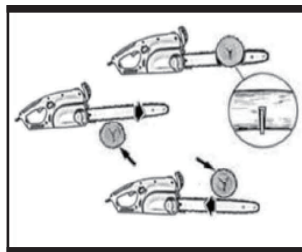
A= Kickback path

B= Kickback reaction zone

The push (pinch kickback) and pull reactions.  
(See Fig. 2b)

A=Pull B= Solid objects C=Push

Kickback may occur when the nose or tip of the guide bar touches an object, or when wood closes in and pinches the saw chain in the cut. Tip contact in some cases may cause a lightning-fast reverse reaction kicking the guide bar up and back toward the operator. Pinching the saw chain along the bottom of the guide bar may pull the saw forward, away from the operator. Pinching the saw chain along the top of the guide bar may push the guide bar rapidly back toward the operator. Any of these reactions may cause you to lose control of the saw, which could result in serious personal injury.



**Fig. 2b**

**CHAIN SAW 2000W TTB355CHN**

## VIBRATION


The European Physical Agents (Vibration) Directive has been brought in to help reduce hand arm vibration syndrome injuries to power tool users. The directive requires power tool manufacturers and suppliers to provide indicative vibration test results to enable users to make informed decisions as to the period of time a power tool can be used safely on a daily basis and the choice of tool. Further Advice can be found at [www.hse.gov.uk](http://www.hse.gov.uk)

Vibration total values (triax vector sum) determined according to EN60745:	
Vibration level during operation	Vibration emission value $a_h = 6.94\text{m/s}^2$
	Uncertainty $K = 1.5\text{m/s}^2$

The declared vibration emission value should be used as a minimum level and should be used with the current guidance on vibration.

Calculating the actual period of the actual period off use can be difficult and the HSE website has further information.

The declared vibration emission been measured in accordance with a standard listed test stated above and may be used to compare one tool with another. The declared vibration emission value may also be used in a preliminary assessment of exposure.

 **WARNING!** The vibration emission value during actual use of the power tool can differ from the declared value depending on the ways in which the tool is used dependant on the following examples and other variations on how the tool is used:

How the tool is used and the materials being ground or cut.


The tool being in good condition and well maintained.

The use the correct accessory for the tool and ensuring it is sharp and in good condition.

The tightness of the grip on the handles.

And the tool is being used as intended by its design and these instructions.

**This tool may cause hand-arm vibration syndrome if its use is not adequately managed.**

 **WARNING!** identify safety measures to protect the operator that are based on an estimation of exposure in the actual conditions of use (taking account of all parts of the operating cycle such as the times when the tool is switched off and when it is running idle in addition to the trigger time).Note The use of other tools will reduce the users' total working period on this tool.

Helping to minimise your vibration exposure risk.

Maintain this tool in accordance with these instructions and keep well lubricated (where appropriate).

Avoid using tools in temperatures of 10°C or less.

Plan your work schedule to spread any high vibration tool use across a number of days.

Health Surveillance.

All employees should be part of an employer's health surveillance scheme to help identify any vibration related diseases at an early stage, prevent disease progression and help employees stay in work.



### Double insulation:

The tool is double insulated. This means that all the external metal parts are electrically insulated from the mains power supply. This is done by placing insulation barriers between the electrical and mechanical components making it unnecessary for the tool to be earthed.

### Important note:

Be sure the supply is the same as the voltage given on the rating plate. The tool is fitted with a two-core cable and plug. Remove the mains plug from socket before carrying out any adjustment or servicing.

## SYMBOLS



Warning



Read the instruction manual



Double insulation.



Conforms all relevant safety standards



Wear eye protection  
Wear ear protection  
Wear respiratory protection



Wear gloves protection



Wear foot protection



Do not expose to rain



Switch off! Remove plug from mains before cleaning or maintenance

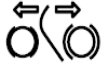


Switch off! Remove plug from the mains immediately if the cable is damaged or cut.

# CHAIN SAW 2000W TTB355CHN



Correct direction of cutting-teeth



Chain brake



Tip contact may cause the guide bar to move suddenly upward and backwards. Which may cause serious injury to user.



Contact of the guide bar tip with any object should be avoided



Do not use one handed when operating the chain saw.



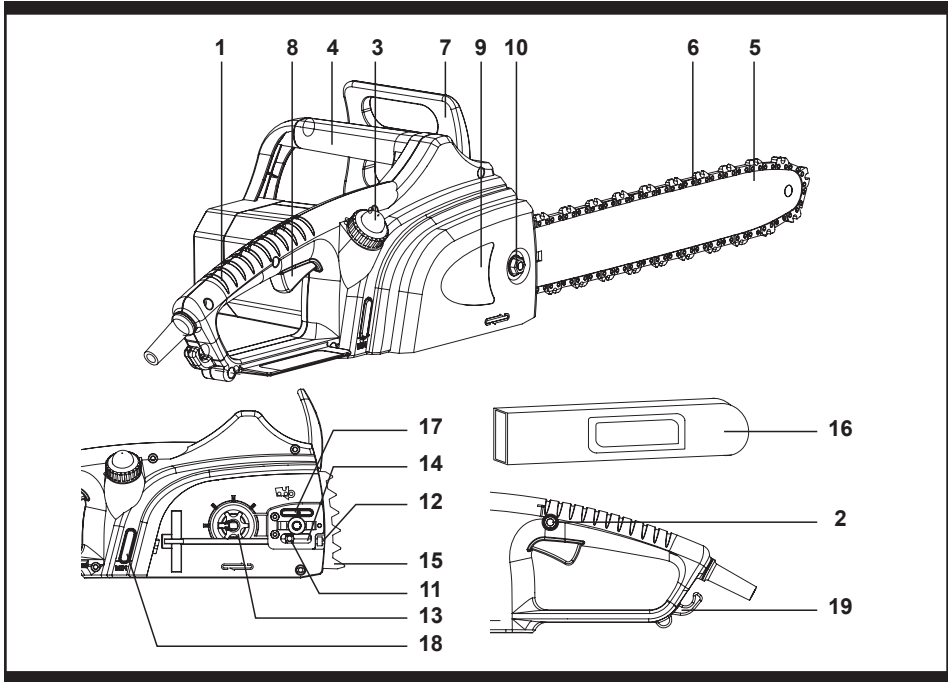
Always use two hands when operating the chain saw.



Take a power tool in the domestic waste! In accordance with European Directive 2002/96/EC on waste electrical and electronic equipment and its implementation in national law, Electric tools collected separately and environmentally friendly recycling are fed. Take advantage of the collection facilities. Ask your local government for the collection systems. If electrical appliances are disposed of, can be poisoned for years while the cause hazardous substances into the groundwater and entering the food chain, or flora and fauna.



Guaranteed sound power level



- 1 Rear handle**
- 2 Safety lock-off button**
- 3 Chain oil cap**
- 4 Front handle**
- 5 Guide bar**
- 6 Chain**
- 7 Safety chain brake lever**
- 8 Switch trigger**
- 9 Chain cover**
- 10 Clamp nut**
- 11 Locking pin**
- 12 Chain tension screw**
- 13 Sprocket**
- 14 Chain catcher**
- 15 Spiked bumper**
- 16 Guide bar cover**
- 17 Chain oil outlet**
- 18 Oil level gauge**
- 19 Cable hook**

**CHAIN SAW 2000W TTB355CHN**

## TECHNICAL DATA

Rated voltage:	230-240V~ 50Hz
Rated power:	2000W
No-load speed:	7600/min
Guide bar length:	405mm
Max. cutting length:	400mm
Chain pitch:	9.525mm (3/8")
Number of chain links:	57
Chain gauge:	1.27mm (0.05")
Saw chain type:	Oregon 91PJ057X
Bar type:	Oregon 549756
Net weight:	5.8kg
Oil tank capacity:	100ml
cable length:	3M

## NOISE DATA

Measured sound pressure level:	84.53 dB (A) K=3 dB (A)
Measured sound power level:	104.53 dB (A) K=3 dB (A)
Guaranteed sound power level:	109 dB (A)
Vibration level:	6.940 m/ s <sup>2</sup>
Uncertainty K:	1.5 m / s <sup>2</sup>

## ACCESSORIES

### Spanner

1PC

The declared vibration value has been measured in accordance with a standard test method and may be used for comparing one tool with another. The declared vibration value may also be used in a preliminary assessment of exposure.

**WARNING!** The vibration emission value during actual use of the tool can differ from the declared value depending on the ways in which the tool is used. Identify safety measures to protect the operator that are based on an estimation of exposure in the actual conditions of use (taking account of all parts of the operating cycle such as the times when the tool is switched off and when it is running idle in addition to the trigger time).

**WARNING!** Due to the power input of this product on start up, voltage drops may occur and this can influence other equipment (e.g. dimming lights). So for technical reasons we advise, if the mains-impedance is  $Z_{max} < 0.39 \text{ Ohm}$ , these disturbance are not expected, If you require future clarification, you may contact your local power supply authority.

The sound intensity level for the operator may exceed 85dB(A) and ear protection measures are necessary.

## BEFORE USE

**WARNING!** Do not connect the chain saw to mains power before it is completely assembled.

Always use gloves when handling the chain.

Your new chain saw may require installation of the guide bar, saw chain, sprocket cover, adjustment of chain, and filling the oil tank with chain lubricating before the chain saw is ready for operation. Do not start the chain saw until the unit is properly assembled. Read all instructions carefully. Do not install any other size bar and chain.

## 1. ACCESSORIES

The chain saw is supplied with the following accessories:  
(See Fig.3)

- Guide bar
- Saw chain
- Chain protection sheath

**NOTE:** If any of the above items are missing contact the helpline.

## 2. CHAIN AND CHAIN BAR ASSEMBLY.

**WARNING!** Assembly methods according to the type of your machine, so please take care to refer to the illustrations and machine type marked on the label. Take great care when assembling to ensure this is performed correctly.

Unscrew the clamp nut with spanner (supplied) and remove chain cover. (See Fig.4)

Ensure the chain tensioning screw (12) is slackened sufficiently to allow the locking pin (11) maximum travel.(see Fig. 5)

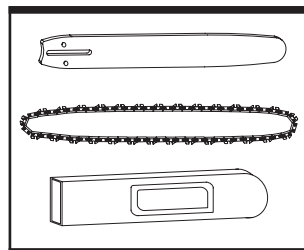


Fig. 3

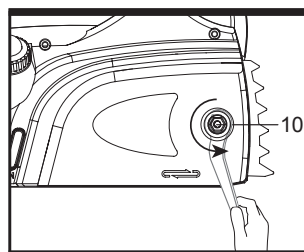


Fig. 4

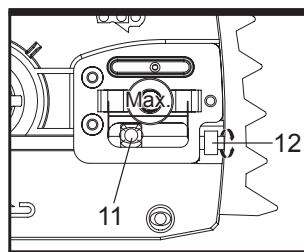
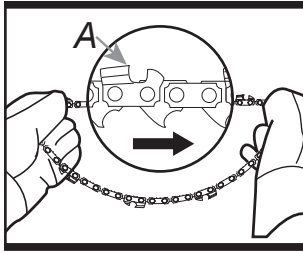


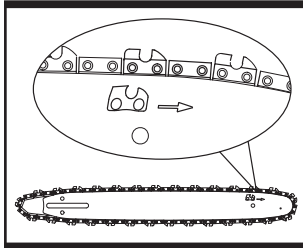
Fig. 5

# CHAIN SAW 2000W TTB355CHN

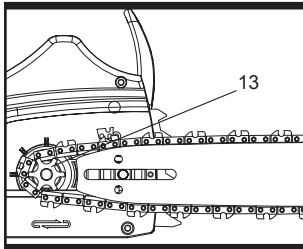


**Fig. 6**

Wearing thick protective gloves, drape the chain over the guide bar ensuring the direction(A) of travel is as marked on the guide bar and it is fully engaged in the guide bar sprocket.(see Fig. 6 & 7)

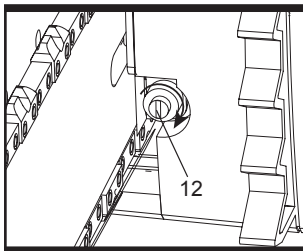


**Fig. 7**



**Fig. 8**

Fit the bar/chain assembly up to the locking pin (11) and tighten chain tension screw (12) for ensure fully engaged on the drive sprocket (13). (see Fig. 8 & 9)



**Fig. 9**

Mount the cover and nut, but do not fully tighten the nut. (see Fig. 10)

### 3. TENSIONING CHAIN

Always check the chain tension before use, after the first cuts and regularly during use, approx. every 5 cuts. Upon initial operation, new chains can lengthen considerably. This is normal during the break-in period, and the interval between future adjustments will lengthen quickly.



**WARNING:** Unplug chain saw from power source before adjusting saw chain tension.



**WARNING:** Cutting edges on chain are sharp. Use protective gloves when handling chain.



**WARNING:** Maintain proper chain tension always. A loose chain will increase the risk of kickback. A loose chain may jump out of guide bar groove. This may injure operator and damage chain. A loose chain will cause chain, chain bar, and sprocket to wear rapidly.



The chain life of the saw chain mainly depends upon sufficient lubrication and correct tensioning.



Avoid tensioning the chain if it is hot, as this will cause the chain to become over tensioned when it cools down.

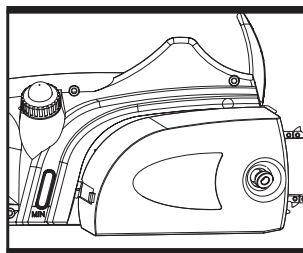
The correct chain tension is reached when the chain can be raised approx. 2-4mm from the chain bar in the centre. This should be done by using one hand to raise the chain against the weight of the machine.

Then tighten clamp nut (10) with spanner. (See Fig.11 & 12).

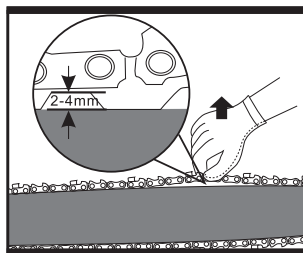


**WARNING!** Tensioning the chain too tightly will overload the motor and cause damage, insufficient tension can provoke chain derailing, whereas a chain tightened correctly provides the best cutting characteristics and prolonged work life.

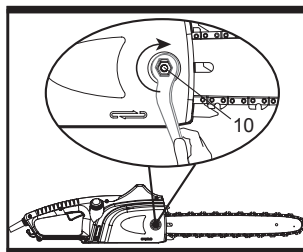
Check the tension regularly because the chain length tends to stretch with use (especially when the chain is new; after the first assembly, the chain tension must be checked after 5 minutes machine operation); in any case do not tighten the chain immediately after use, but wait until it cools down. In cases where the loosened chain needs to be adjusted, always unscrew the adjustable outside ring before adjusting the chain tensioning screw/knob; adjust the tension and tighten the bar retaining nut/knob accordingly.



**Fig. 10**



**Fig. 11**



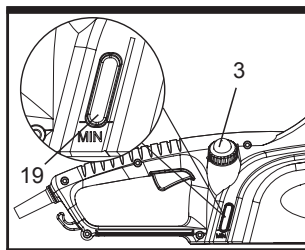
**Fig. 12**

# CHAIN SAW 2000W TTB355CHN

## 4. CHAIN AND BAR LUBRICATIPON.

**!** **WARNING!** The chain saw is not supplied filled with oil. It is essential to fill with oil before use. Never operate the chain saw without chain oil or at an empty oil tank level, as this will result in extensive damage to the product.

**!** Never starve the bar and chain of lubrication oil. Running the saw dry or with too little oil will decrease cutting efficiency, shorten chain saw life, and cause rapid during of the chain and excessive wear of the bar from overheating. Too little is evidenced by smoke or bar discoloration.



**Fig. 13**

Adequate lubrication of the saw chain during cutting operations is essential to minimize friction with the guide bar. your chainsaw is equipped with an automatic oiler system. The oiler automatically delivers the proper amount of oil to the bar and chain.

The oil tank holds 100ml of oil, enough to lubricate the chain for 20-25 minutes of cutting. Check oil level gauge (19) prior to starting and regularly during operation. Refill oil when oil level is lower than "MIN" marking.(See Fig.13)

### **Filling oil tank:**

- 1). Set chain saw on any suitable surface with oil filler cap (3) facing upward.
- 2). Clean area around the oil filler cap with cloth.
- 3). Add chain saw oil until reservoir is full. You can choose SAE30 or SAE10.
- 4). Avoid dirt or debris entering oil tank, refit oil filler cap and tighten.



**WARNING!** To allow venting of the oil reservoir, small breather channels are provided between the oil filler cap and the strainer, to prevent leakage ensure machine is left in a horizontal position (oil filler cap uppermost) when not in use. It is important to use only the recommended oil to avoid damage to the chain saw. Never use recycled/old oil. Use of non approved oil will invalidate the warranty.

**CAUTION!** The oil tank level should be frequently checked during operation to avoid starving the bar and chain of lubrication.

**NOTE:** Your chain saw is equipped with an Automatic Oiler system and is the only source of lubrication for the bar and saw chain.

## 5. Power connection.

Always use the correct supply voltage. The power supply voltage must match the information quoted on the tool identification plate.

- 1). We recommend that you always use the appliance supplied via a Residual Current Device (RCD) with a tripping current of not more than 30mA.
- 2). Use only extension cables suitable for outdoor use, preferably with a high visibility cord color with the following specification:
  - For extension cables up to 25 meters, use a wire cross section of 1.5mm<sup>2</sup>.
  - For extension cables over 25 meters and less than 40 meters, use a wire cross section of 2.5mm<sup>2</sup>.
- 3). Always completely unwind cable reels.

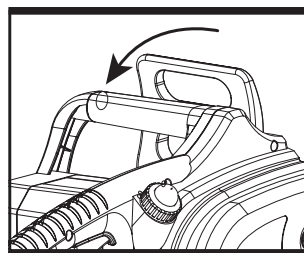
## OPERATION INSTRUCTIONS

### 1. START CHAIN SAW.

**WARNING!** Check the voltage and current supply. The voltage and current supply must comply with the ratings on the type plate.

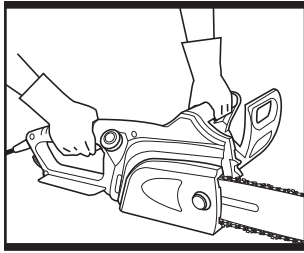
**WARNING!** Ensure the extension cord is of the proper size and type for your saw ( $\geq 1.5\text{mm}^2$ )

- 1). Make sure the chain brake level is disengaged. The motor will not start if the chain brake is in the engaged position. Disengage the chain brake level by pulling backward toward the front handle. (See Fig. 14).

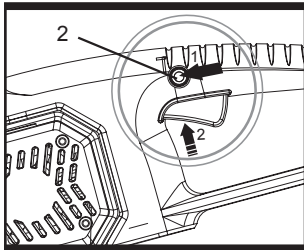


**Fig. 14**

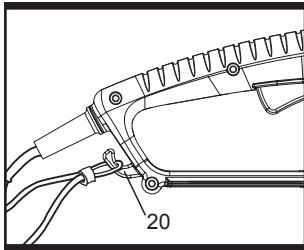
# CHAIN SAW 2000W TTB355CHN



**Fig. 15a**



**Fig. 15b**



**Fig. 16**

2). Grip the product with both hands, left hand holding the front handle (do not hold chain brake) and the right hand holding the rear handle. Press the lock-off button, then fully press the switch trigger and hold in this position. The lock-off button can now be released now. (See Fig. 15a, 15b).

**NOTE:** It is not necessary to maintain pressure on the lock-off button once the switch trigger is squeezed and the motor is running. The lock-off button is a safety device to avoid accidental starting

## **2. STOP CHAIN SAW.**

The chain saw will automatically stop when the switch trigger is released. The lock-off button will have to be depressed and the switch trigger squeezed to restart the motor.

**3. An extension cord retainer (20)** is built into the rear handle that prevents the extension cord from pulling out of the handle. To use this feature, simply double the extension cord, about a foot from the end, and insert it into the hole of the handle. Hook the loop formed by doubling the cord over the cord retainer. Gently tug on the cord to ensure that it is firmly retained in the handle. Plug the receptacle end of the extension cord into the tool's power supply cord. (See Fig. 16).

## **4. CHAIN BRAKE.**

The chain brake is a safety mechanism activated through the front hand guard. When kickback occurs, chain stops immediately. The following function check should be carried out at regular intervals. The purpose of the chain brake testing is to reduce the possibility of injury due to kickback.

**WARNING!** If the chain and motor fail to stop when the chain brake is engaged, take the saw to the nearest authorized dealer. Do not use the saw if the chain brake is not in proper working.

- 1). Make sure the chain brake level is disengaged; (See Fig. 17a)
- 2). Place the chain saw on any suitable flat surface.
- 3). Plug the unit into the power source;
- 4). Grasp the front handle with your left hand. Thumb and fingers should encircle the handle;
- 5). Grasp the rear handle with your right hand. Thumb and fingers should encircle the handle;
- 6). Press the lock-off button with your right thumb, then fully press the switch trigger with your index finger and hold in this position;
- 7). While the motor is running, activate the chain brake level by rolling your left hand forward against the chain brake level; (See Fig. 17b)
- 8). Chain and motor should stop immediately.

**NOTE:** The motor will not start if the chain brake level is in the engaged position.



**CAUTION!** The chain brake level should not be used for starting and stopping the saw during normal operation.

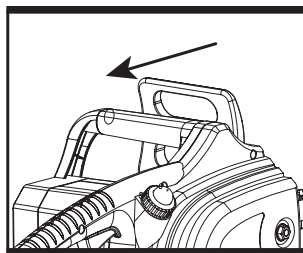
### 5. KICKBACK. (See Fig. 18)

Kickback is the sudden backward/upward motion of the chain saw, occurring when the chain (at the tip of the chain bar) comes in contact with a log or wood, or when the chain becomes jammed.

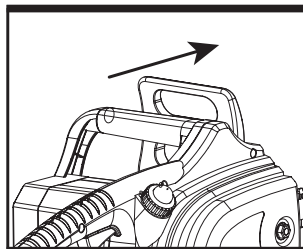
When kickback occurs the chain saw reacts unpredictably and can cause severe injuries to the operator or bystanders. Particular attention must be given when sawing sideward, slanted or during length cuts, as the spiked bumper usually can not be applied.

To avoid kickback:

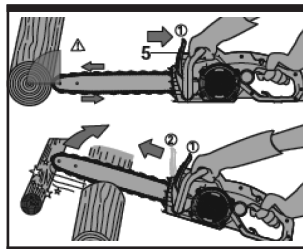
- Saw with guide bar at a flat angle:
- Never work with a loose, widely stretched or the heavily worn out chain:
- Ensure chain is sharpened correctly:
- Never saw above shoulder height:
- Never work with the tip of the guide bar:
- Always hold the chain saw firmly with both hands:
- Always use a low kickback chain:
- Apply the metal gripping teeth for leverage:
- Ensure correct chain tension:



**Fig. 17a**

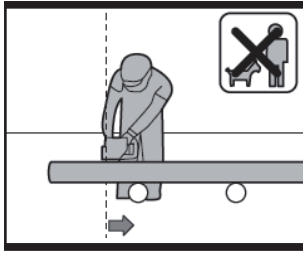


**Fig. 17b**

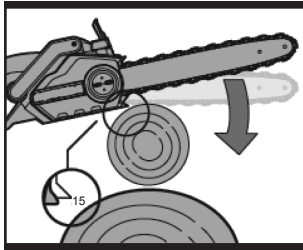


**Fig. 18**

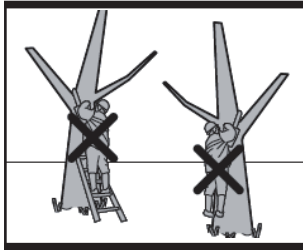
# CHAIN SAW 2000W TTB355CHN



**Fig. 19**



**Fig. 20**



**Fig. 21**

## 6. GENERAL BEHAVIOR.

Always hold the chain saw firmly with both hands. Front grip with the left hand and rear grip with the right hand. Fully grip both handles at all times during operation. Never operate chain saw using only one hand. Ensure power cord is located to the rear, away from the chain and wood and so positioned that it will not be caught on branches or the like during cutting. (See Fig.18)

Use the chain saw only with secure footing. Hold the chain saw at the right-hand side of your body. (See Fig.19)

- The chain must be running at full speed before it makes contact with the wood. Use the metal gripping teeth to secure the saw onto the wood before starting to cut. Use the spiked bumper (15) as a leverage point while cutting. (See Fig.20)

- Reset the gripping teeth at a low point when sawing thicker logs by pulling the chain saw slightly backwards until the gripping teeth release, and reposition at lower level to continue sawing. Do not remove the saw completely from the wood.

- Do not force the chain while cutting, let the chain do the work, using the gripping teeth to apply minimal leverage pressure.

- Do not operate the chain saw with arms fully extended or attempt to saw areas which are difficult to reach, or on a ladder. Never use the chain saw above shoulder height. (See Fig.21)

- Sawing is optimized when the chain speed remains steady during cutting.

- Beware when reaching the end of the cut. The weight of the saw may change unexpectedly as it cuts free from the wood. Accidents can occur to the legs and feet. Always remove the saw from a wood cut while the saw is running.

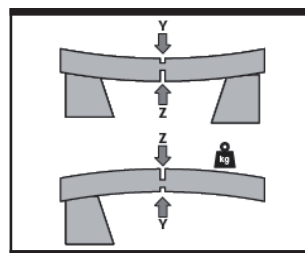
## 7. CUTTING LOGS.

Observe the following safety instructions:

- Support logs so that the face sides at the cut do not close in against each other, which would result in the chain being jammed or pinched. (See Fig.22)
- Position and set short logs safety prior to sawing. Saw only wood or wooden objects. When sawing, always take care to avoid hitting stones, nails, ect, as these could be thrown up or cause damage to the chain or serious injury to the operator or bystanders.
- Keep a running saw clear or wire fencing or the ground. Use of the saw to thin out branches or bushes is not approved.
- Length cuts must be carried out with care, as leverage with the spiked bumper (15) is not possible. Saw at a flat angle to avoid kickback.
- When working on a slope, operate above or to the side of the trunk or laying tree.
- Be careful not to trip over tree stumps, branches, roots, etc.

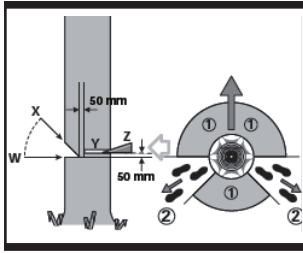
## 8. CUTTING WOOD UNDER TENSION. (See Fig.22)

There is a high risk of accidents when sawing wood, branch or trees under tension. Be extremely careful. Leave saw jobs like these to professionals. When sawing logs supported on both ends, start the cut from above (Y) about 1/3 of the diameter into the log and then finish the cut (Z) from below, in order to avoid contact of the chain saw with the ground. When sawing logs supported on only one end, start the cut from below (Y) about 1/3 of the diameter into the log and finish the cut from above (Z) in order to avoid log splitting or jamming of the chain saw.



**Fig. 22**


**CHAIN SAW 2000W TTB355CHN**



**Fig. 23**

## 9. GENERAL CUTTING INSTRUCTIONS.

### 1). Felling trees. (See Fig. 23)

 Always wear hard hat to protect head against falling branches. The chain saw can only be used to fell trees smaller in diameter than the length of the guide bar.

- Secure work area. ensure no persons or animals are in the vicinity of the falling tree. Never attempt to free a jammed saw with the motor running. Use wooden wedges to free chain and guide bar.

When cutting and felling operations are being performed by two or more persons, at the same time, the felling operations should be separated from the cutting operation by a distance of at least twice the height of the tree being felled. Trees should not be felled in a manner that would endanger any person, strike any utility line or cause any property damage. If the tree does make contact with any utility line, the company should be notified immediately. The chain saw operator should keep on the uphill side of the terrain as the tree is likely to roll or slide downhill after it is felled.

- An escape path should be planned and cleared as necessary before cuts are started. The escape path should extend back and diagonally to the rear of the expected line of fall.

- Before felling is started, consider the natural lean of the tree, the location of larger branches and the wind direction to judge which way the tree will fall. Remove dirt, stones, loose bark, nails staples, and wire from the tree.

- Notching undercut: Make the notch (x-w) 1/3 the diameter of the tree, perpendicular to the direction of falls as make the lower horizontal notching cut first. This will help to avoid pinching either the saw chain or the guide bar when the second notch is being made.

- Felling back cut: make the felling back cut (Y) at least 50 mm higher than the horizontal notching cut. Keep the felling back cut parallel to the horizontal notching cut. Make the felling back cut so enough wood is left to act as a hinge. The hinge wood keeps the tree from twisting and falling in the wrong direction. Do not cut through the hinge.

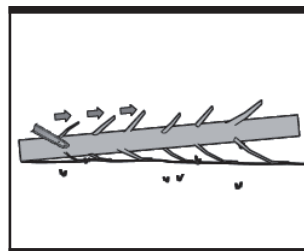
- As the felling gets close to the hinge the tree should begin to fall. If there is any chance that the tree may not fall in desired direction or it may rock back and bind the saw chain, stop cutting before the felling back cut is complete and use wedges of wood, plastic, or aluminum to open the cut and drop the tree along the desired line of fall.

- When the tree begins to fall remove the chain saw from the cutting, stop the motor, put the chain saw down, and then use the retreat path planned. Be alert for overhead limbs falling and watch your footing. To complete the felling

operation, drive a wedge (Z) into the horizontal cut.  
- Beware of falling branches when the tree starts to move.

### 2). Limbing a tree. (See Fig. 24)

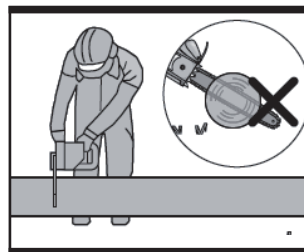
Limbing is removing the branches from a fallen tree. When limbing leave larger lower limbs to support the log off the ground. Remove the small limbs in one cut as illustrated. Branches under tension should be cut from the bottom up to avoid binding the chain saw



**Fig. 24**

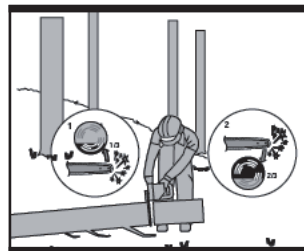
### 3). Bucking a log.

- Bucking is cutting a log into lengths. It is important to make sure your footing is firm and your weight is evenly distributed on both feet. When possible, the log should be raised and supported by the use of limbs, logs or chocks. Follow the simple directions for easy cutting. When the log is supported along its entire as illustrated, it is cut from the top (overbuck). (See Fig. 25)



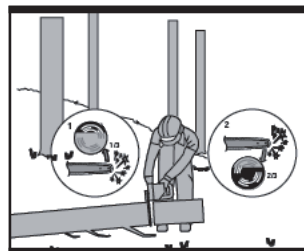
**Fig. 25**

- When the log is supported on one end, as illustrated, cut 1/3 the diameter from the underside (underbuck). Then make the finished cut by overbucking to meet the first cut. (See Fig. 26)



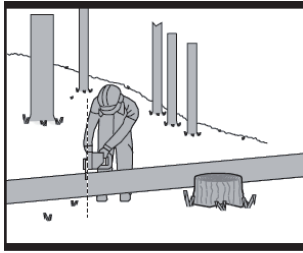
**Fig. 26**

- When the log is supported on both ends, as illustrated, cut 1/3 the diameter from the top overbuck. Then make the finished cut by underbucking the lower 2/3 to meet the first cut. (See Fig. 27)



**Fig. 27**

# CHAIN SAW 2000W TTB355CHN



**Fig. 28**

- When bucking on a slope always stand on the uphill side of the log, as illustrated. When “cutting through”, to maintain complete control release the cutting pressure near the end of the cut without relaxing your grip on the chain saw handles. Don’t let the chain contact the ground. After completing the cut, wait for the saw chain to stop before you move the chain saw. Always stop the motor before moving from tree to tree. (See Fig. 28)

## MAINTENANCE AND REPAIR



**WARNING!** Before any work on the machine itself, pull the mains plug from the socket. For ensure long and reliable service, carry out the following maintenance regularly:

- Regularly check for obvious defects such as loose, dislodged or damaged chain and guide bar, loose fixings and worn or damaged components.
- Check that covers and guards are undamaged and correctly fitted. Carry out necessary maintenance or repairs before using the chain saw.
- If the chain saw should happen to fail despite the care taken in manufacturing and testing, repair should be carried out by an authorized customer service agent.

**NOTE:** Before returning, ensure all oil in the oil tank has been emptied.

### 1. Replacing/changing chain and guide bar.

The circular groove of the guide bar will wear particularly on the lower edge with time. When replacing the chain turn the chain bar 180° to allow even wear, thus extending chain bar life.

Check drive sprocket. If it is worn out or damaged due to strain, have it exchanged by an authorized service agent. If the chain bar is worn out or damaged, have it exchanged by an authorized service agent

### 2. Lubricate drive sprocket.

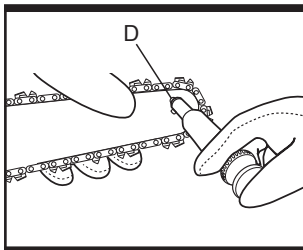
1). Unplug the chain saw from the power source.

**NOTE:** It is not necessary to remove the saw chain to lubricate the guide bar sprocket tip. Lubrication can be done on the job.

2). Clean the guide bar sprocket tip.

3). Using disposable lube gun, insert needle nose into the lubrication hole (D) and inject grease until it appears at the outside edge of the sprocket tip. (See Fig.29).

4). Make sure that the chain brake is deactivated. Rotate the saw chain by hand. Repeat the lubrication procedure until the entire sprocket tip has been greased.

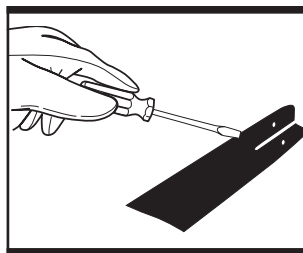


**Fig. 29**



### 3. Clean Guide Bar Rails

- 1). Remove side cover, bar and chain.
- 2). Using a screwdriver, putty knife, wire brush or other similar instrument, clear residue from the rails on the guide bar. This will keep the oil passages open to provide proper lubrication to the bar and chain.(See Fig.30)
- 3). Reinstall the bar, chain (and adjust tension), sprocket cover and bar bolt retaining nuts. (See Section Guide bar/ saw chain installation)



**Fig. 30**

### 4. Guide bar maintenance

Most guide bar problems can be prevented mere by keeping the chain saw well maintained. Incorrect filing and non-uniform cutter and depth gauge settings cause most guide bar problems, primarily resulting in uneven bar wear. As the bar wears unively, the rails widen, which may cause chain clatter and difficulty in making straight cuts. Insufficient guide bar lubrication and operating the saw with a chain this is too tight willl contribute to repid bar wear(see Section Chain maintenance instructions). To help minimize bar wear, the following guide bar maintenance is recommended.

### 5. Oil passages

Oil passages at bar pad should be cleaned to ensure proper lubrication of the bar and chain during operation. This can be done using a soft wire small enough to insert into the oil discharge hole.

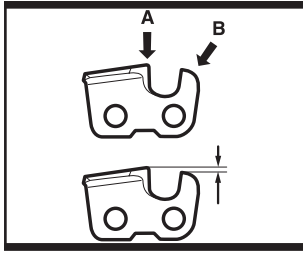
NOTE: The condition of the oil passages can be easily checked. If the passages are clear, the chain will automatically give off a spray of oil within seconds of starting the saw. Your saw is equipped with an automatic oiler system.

### 6. Chain maintenance instructions

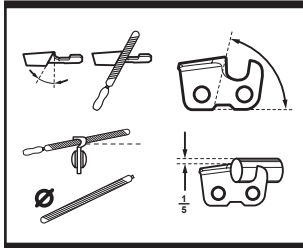
**Warning!** Unless you have experience and specialized training for dealing with kickback (see Safety Precautions), always use a low-kickback saw chain, which significantly reduces the danger of kickback. Low-kickback saw chain does not completely eliminated kickback. A low-kickback or “safety chain”, should never be regarded as total protection against injury.

A low-kickback saw chain should always be used in conjunction with other kickback protection vices such as the chain brake/Hand Guard furnished with your unit. Always use a replacement saw chain designed as “low-kickback” or a saw chain which meets the low-kickbackperformance. A standard saw chain (a chain which soes not have the kickback reducing guard links) should only be used by an experienced professional chain saw operator.

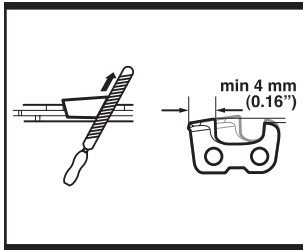
**CHAIN SAW 2000W TTB355CHN**



**Fig. 31**



**Fig. 32**



**Fig. 33**

## 7. Sharpening chain

- 1). Never saw with a blunt chain. The chain is blunt when you have to push the chainsaw into the tree and the chips are very small. The saw-link is the part of the chain which does the sawing.
- 2). The height-distance between the tooth A and the ridge B is the cutting depth. When sharpening the chain you have to consider the next points (See Fig.31 & 32):

- File-angle
- Cutting -angle
- File-position
- Diameter of round file
- File-depth

For correct sharpening of the chain you need good tools; for example a mould to obtain a correct file-angle.



**Warning!** The risk of kick-back increases when:

- file-angle is too big
- cutting-angle is too small
- diameter of round file is too small

- 3). Sharpening the tooth. (See Fig.33)

To sharpen the teeth of the saw you need round file and a file mould. Consult a specialist store in chain saws for these items.

- Check if the chain is stretched out completely. otherwise the chain is not stable enough and cannot be sharpened correctly.
- Always file from the inside of the tooth to the outside. Always lift up the file when you start sharpening another tooth. First file all teeth on one side, turn round the chain saw and then file the teeth on the other side.
- After filing, the teeth should all have the same length. When the length of the teeth is only 4mm, the chain is worn and should be replaced.

## TROUBLESHOOTING

Symptom	Possible cause	Fault correction
Chain saw fails to operate	<ul style="list-style-type: none"> <li>-- Kickback brake is activated</li> <li>-- No power</li> <li>-- Mains socket faulty</li> <li>-- Extension cord damaged</li> <li>-- Fuse faulty</li> </ul>	<ul style="list-style-type: none"> <li>-- Pull hand guard back in position (Fig.18a)</li> <li>-- Check power</li> <li>-- Use another socket</li> <li>-- Check cord, replace</li> <li>-- Replace fuse</li> </ul>
Chain saw operates intermittently	<ul style="list-style-type: none"> <li>-- Extension cord damaged</li> <li>-- Loose connection</li> <li>-- Internal wiring defective</li> <li>-- On/Off switch defective</li> </ul>	<ul style="list-style-type: none"> <li>-- Check cord, replace</li> <li>-- Contact service agent</li> <li>-- Contact service agent</li> <li>-- Contact service agent</li> </ul>
Dry chain	<ul style="list-style-type: none"> <li>-- No oil in reservoir</li> <li>-- Vent in oil filler cap clogged</li> <li>-- Oil passage clogged</li> </ul>	<ul style="list-style-type: none"> <li>-- Refill oil</li> <li>-- Clean cap</li> <li>-- Clean oil passage outlet</li> </ul>
Kickback Brake / Rundown brake	Brake does not stop chain	Contact service agent
Chain/chain bar overheats	<ul style="list-style-type: none"> <li>-- No oil in reservoir</li> <li>-- Vent in oil filler cap clogged</li> <li>-- Oil passage clogged</li> <li>-- Chain is over tensioned</li> <li>-- Dull chain</li> </ul>	<ul style="list-style-type: none"> <li>-- Refill oil</li> <li>-- Clean cap</li> <li>-- Clean oil passage outlet</li> <li>-- Adjust locking knob</li> <li>-- Sharpen chain or replace</li> </ul>
Chain saw rips, vibrates, does not saw properly	<ul style="list-style-type: none"> <li>-- Chain tension too loose</li> <li>-- Dull chain</li> <li>-- Chain worn out</li> <li>-- Chain teeth are facing in the wrong direction</li> </ul>	<ul style="list-style-type: none"> <li>-- Adjust locking knob</li> <li>-- Sharpen chain or replace</li> <li>-- Replace chain</li> <li>-- Reassemble with chain in correct direction</li> </ul>

WARNING! Never use tools with defective On/Off switches or defective Kickback brake (Hand Guard).

WARNING! If the chain saw does not perform properly, or sound are abnormal, or motor cannot be started, or stopped as described, or the chain brake does not work properly, or any other irregularity, or malfunction occurs, do not attempt to repair the chain saw by yourself. Please contact helpline or local service center.

# CHAIN SAW 2000W TTB355CHN

## ENVIRONMENTAL PROTECTION



Waste electrical products should not be disposed of with household waste. Please recycle where facilities exist. Check with your Local Authority or retailer for recycling advice.

For further information visit [www.recycle-more.co.uk](http://www.recycle-more.co.uk).

## UK PLUG REPLACEMENT

The fuse in the main plug of your garden power tool should always be replaced with one of identical rating. Check the voltage given on your garden power tool matches the supply voltage. The garden power tool is supplied with a fitted plug, however if you should need to fit a new plug follows the instruction below.

### IMPORTANT:

The wires in the mains lead are coloured in accordance with the following code:

**Blue – Neutral**

**Brown – Live.**

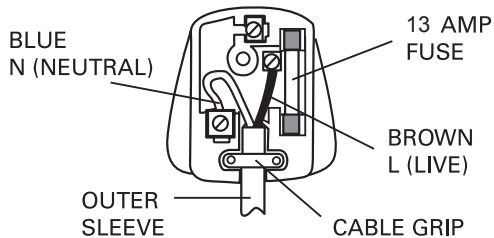
As the colours of the wires in the mains lead of this appliance may not correspond with the coloured markings identifying the terminals in your plug, proceed as follows:

The wire which is coloured **blue** must be connected to the terminal which is marked with **N**.

The wire which is coloured **brown**, must be connected to the terminal, which is marked with the letter **L**.

**Warning:** Never connect live or neutral wires to the earth terminal of the plug. A 13AMP (BS1363/A) plug must be used and a 13AMP fuse must be fitted.

**NOTE:** If a moulded plug is fitted and has to be removed take great care in disposing of the plug and severed cable, it must be destroyed to prevent engaging into a socket. If the supply cord is damaged it must be replaced by a service agent or a similarly qualified person in order to avoid hazard



# TITAN®

## Declaration of Conformity

We, Importer  
**TITAN Power Tools (UK) Ltd**  
Trade House, Mead Avenue, BA22 8RT

Declare that the product  
**Designation: 2000W CHAIN SAW**  
**Model: TTB355CHN**

Complies with the following directives:  
**2006/42/EC** - Machinery Directive  
**2004/108/EC** - Electromagnetic Compatibility Directive  
**2006/95/EC** - Low Voltage Directive  
**2011/65/EC** - Restrictions of the Use of Certain Hazardous Substances in Electrical and Electronic Equipment  
**2002/96/EC and 2003/108/EC** - Waste Electrical and Electronic Equipment (WEEE)  
**2000/14/EC amended by 2005/88/EC** - Noise Emission in the Environment by Equipment for Use Outdoors Directive

Notified body: TÜV Rheinland LGA Products GmbH  
Notified body identification number: 0197

EC-Type examination certificate no.: BM 50191513

The conformity assessment followed was according to Annex III of the directive for equipment listed in schedule 1 / article 13 the chosen conformity assessment route Internal control of production (schedule 10 / Annex V)

- Measured Sound Power Level **104.53 dB(A)**
- Guaranteed Sound Power Level 109 dB(A)

Standards and technical specifications referred to:

**EN60745-1: 2009**  
**EN60745-2-13: 2009**  
**EN55014-1:2006+A1:2009**  
**EN55014-2:1997+A1:2001+A2:2008**  
**EN61000-3-2:2006+A1:2009+A2:2009**  
**EN61000-3-11:2000**

Authorised signatory and technical file holder

Date: 29/11/12

Signature: *P. C. Harries*

Name / title: Peter Harries / Quality Manager

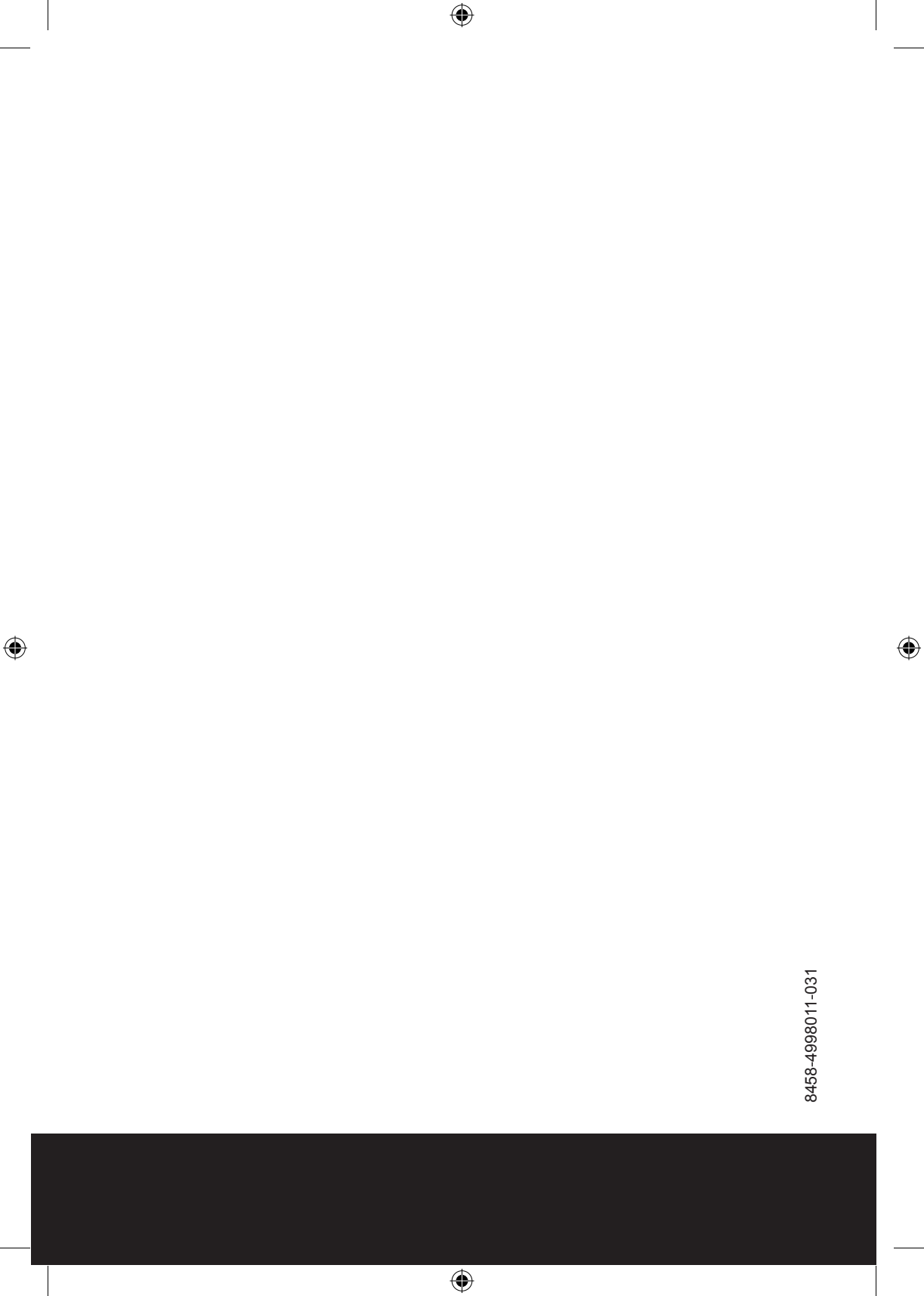
Titan Power Tools (UK)Ltd. Trade House, Mead Avenue, BA22 8RT



## CHAIN SAW 2000W TTB355CHN



**CHAIN SAW 2000W TTB355CHN**



8458-49980 11-031

