

Please read instructions before commencing installation and retain for future reference.

Specification:

Recessed downlights with pressed steel body and die cast aluminium front bezel with intumescent seals to give 30, 60 and 90minutes fire protection in an appropriate 30, 60 and 90min rated ceiling.

Protection against electric shock: Class II (Double insulated do not earth!)

Lamp type: 240V GU/GZ10 Max. 50W

Dimensions:	Cut-out	Overall Diameter	Depth	Lamp retention
RF201/RF201MP	Ø74mm	Ø91mm	135mm	Twist & lock bezel
RF208	Ø86mm	Ø106mm	140mm	Twist & lock bezel

Temperature range: -20°C < ta < 40°C

Supply: 240V 50Hz

Ingress Protection: IP20



Luminaire designed to be used only with self-shielded tungsten halogen lamps or self-shielded metal halide lamps



Luminaires not suitable for covering with thermally insulating material

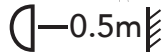

Suitable for mounting on normally flammable surface
Minimum distance from illuminated object is 0.5 metre



Against the use of cool-beam lamps

Complies with BS EN60598, BS5250, BS476 Parts 20, 21 & 23

Installation:

!Electrical products can cause death or injury, or damage to property. If in any doubt about the installation or use of this product, consult a competent electrician.

- 1 Ensure mains supply is switched off.
- 2 Mark ceiling with appropriate cut-out size.
- 3 Before cutting, ensure that the hole does not impinge on joists, pipe work, cables or other building services.
- 4 Ensure there is at least 100mm of free space around and 50mm above the luminaire. Do not cover the luminaire with thermal insulation.
- 5 Connect supply cables Live and Neutral to fitting terminals (polarity is unimportant). Do Not Earth!
- 6 Fit springs in position on luminaire that is appropriate to the ceiling thickness and offer luminaire up to cut-out with the longer leg of each spring being held vertically. The luminaire is retained in position by the spring tension between the short and the long leg of each spring against the ceiling.
- 7 Lamp installation and replacement:

!Ensure mains supply is off. !When operating the luminaire is too hot to touch. Switch off and allow to cool before undertaking any maintenance work.

RF201, RF201MP & RF208: twist bezel inner ring anticlockwise to unlock, unclip the lamp from the retaining spring at the back of the ring, hold lamp holder firmly and rotate lamp 1/8 turn anti-clockwise to remove, clockwise to insert.

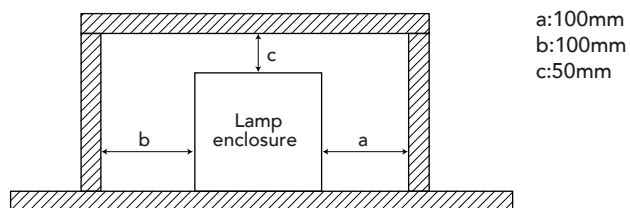

The Installation must be carried out by an electrician

Installation diagram:

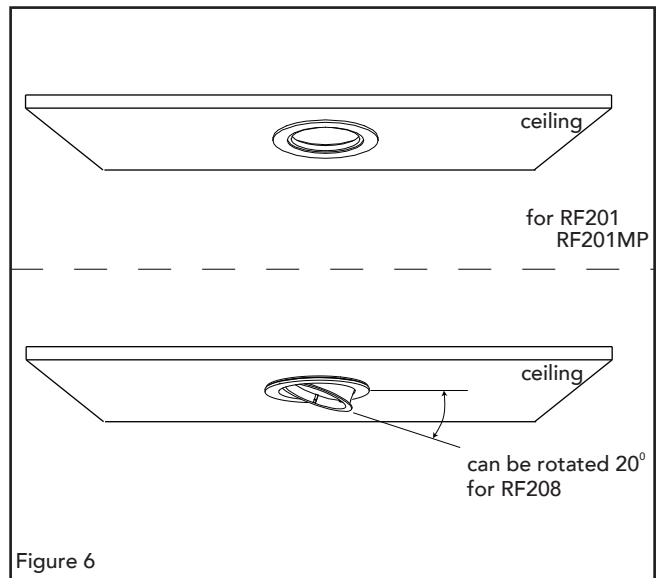
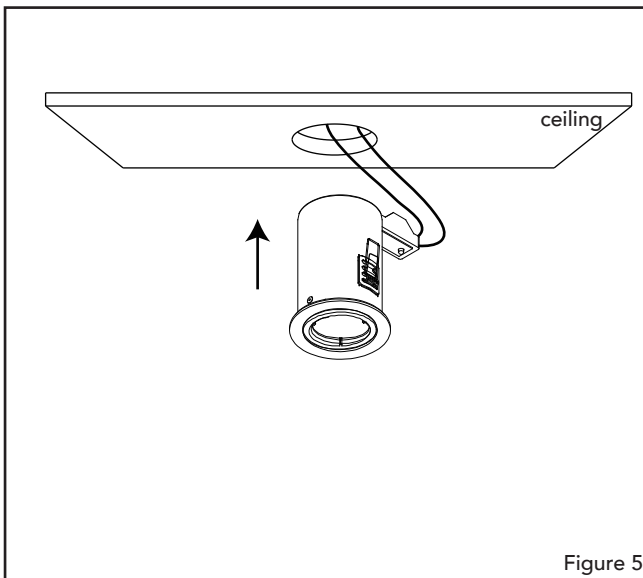
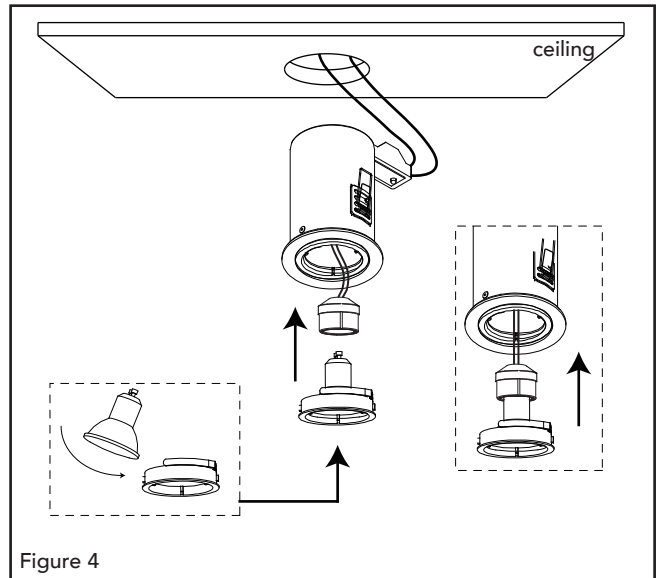
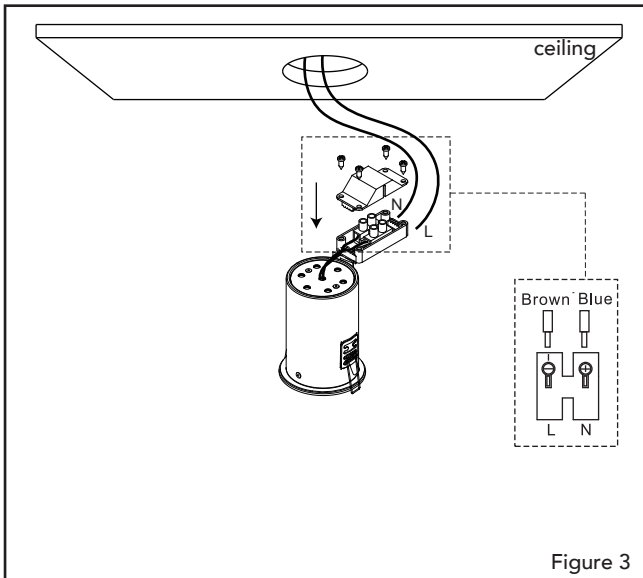
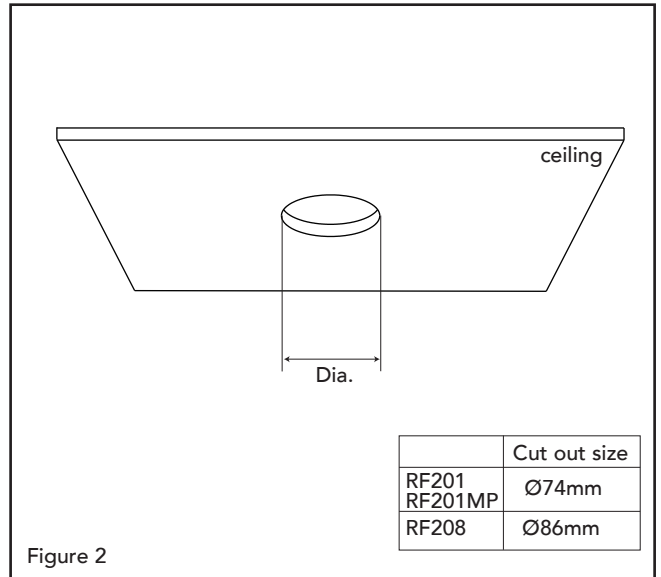
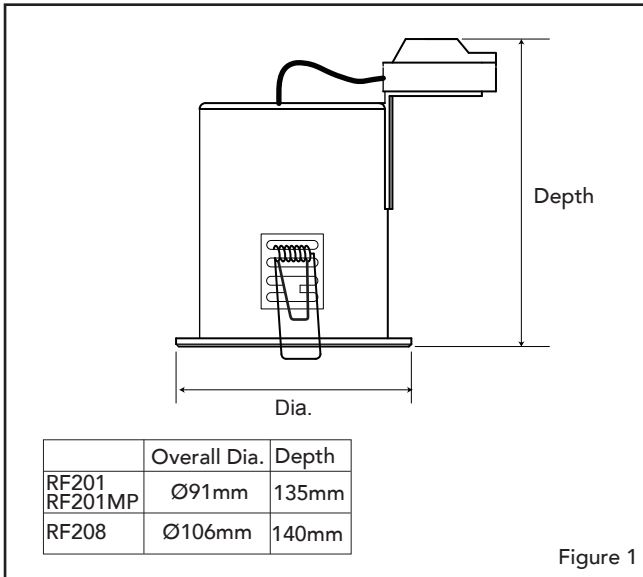

The Installation must be carried out by an electrician

