

# TITAN®

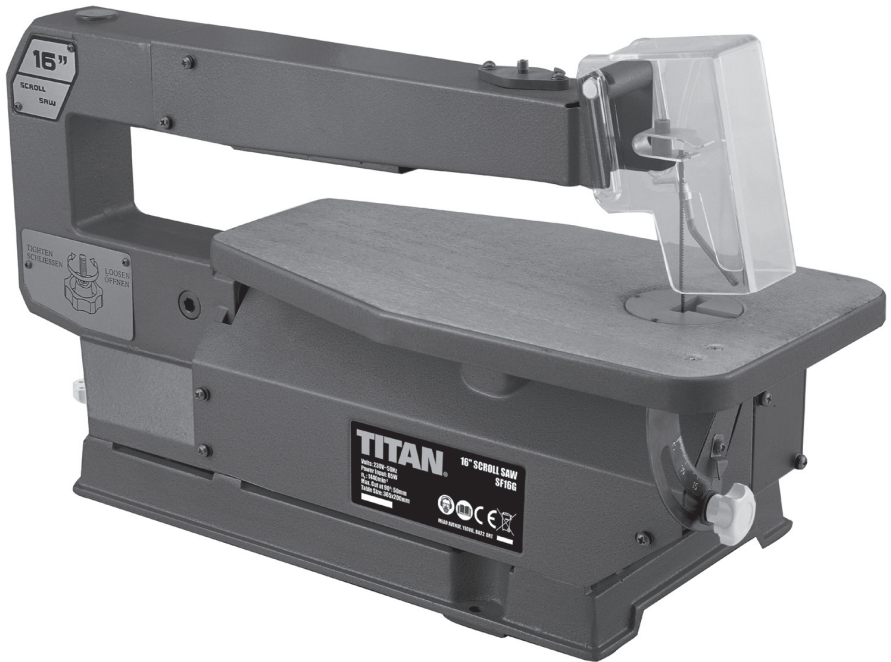

**12** month  
Full  
Manufacturer's  
Warranty

## SAFETY AND OPERATING MANUAL

### 16" SCROLL SAW

### SF16G

# TITAN®

**Congratulations on your purchase of a TITAN power tool from Screwfix Direct Ltd. We want you to continue getting the best performance from it so this handbook includes information on safety, handling and care. Please retain this handbook in case you need to refer to any of the information in the future.**

**Your TITAN power tool comes with a 12-month guarantee, so should it develop a fault within this period contact Screwfix Direct Ltd on Freephone 0500 41 41 41.**

## **GUARANTEE**

This **TITAN** product carries a Screwfix Direct Ltd guarantee of 12 months. If your product develops a fault within this period, you should, in the first instance contact Screwfix Direct Ltd on Freephone 0500 41 41 41. If the fault occurs within the first 12 months, you may return the goods for a full refund or we will repair or replace the goods if you prefer. When repair is not practical or identical goods are not available, alternative goods of similar specification and quality will usually be provided but, failing this, you will be offered a partial or full refund depending on the time period since purchase.

This guarantee specifically excludes losses caused due to:

- Fair wear and tear
- Misuse or abuse
- Lack of routine maintenance
- Failure of consumable items (such as batteries)
- Accidental damage
- Cosmetic damage
- Failure to follow manufacturer's guidelines
- Loss of use of the goods
- Repairs attempted by anyone, unless authorised by Screwfix Direct Ltd.

This guarantee does not affect your statutory rights. This guarantee is only valid in the UK.

For further technical advice, spare parts or repair service (outside of guarantee) please contact the customer helpline number on 0845 607 6380.

# SAFETY INSTRUCTIONS



**WARNING!** Read all instructions. Failure to follow all instructions listed below may result in electric shock, fire and/or serious injury.

## SAVE THESE INSTRUCTIONS

### 1. **Keep the work area clean.**

Cluttered areas and benches invite injuries.

### 2. **Consider work area environment.**

Do not expose power tools to rain. Do not use power tools in damp or wet locations. Keep the work area well lit. Do not use tools in the presence of flammable liquids or gases.

### 3. **Guard against electric shock.**

Avoid body contact with earthed or grounded surfaces (e.g. pipes, radiators, ranges, refrigerators).

### 4. **Keep children away.**

Do not let persons, especially children, not involved in the work touch the tool or the extension cord and keep them away from the work area.

### 5. **Store idle tools.**

When not in use, tools should be stored in a dry, high or locked up place, out of reach of children.

### 6. **Do not force the tool.**

It will do the job better and safer at the rate for which it was intended.

### 7. **Use the right tool.**

Do not force small tools to do the job of a heavy-duty tool. Do not use tools for purposes not intended, for example, do not use circular saws to cut tree limbs or logs.

### 8. **Dress properly.**

Do not wear loose clothing or jewellery, they can be caught in moving parts. Non-skid footwear are recommended when working outdoors. Wear protective hair covering to contain long hair.

### 9. **Use protective equipment.**

Use safety glasses. Use face or dust mask if working operations create dust.

### 10. **Connect dust extraction equipment.**

If the tool is provided for the connection of dust extraction and collecting equipment, ensure these are connected and properly used.

### 11. **Do not abuse the cord.**

Never yank the tool to disconnect it from the socket. Keep the cord away from heat, oil and sharp edges.

### 12. **Secure work.**

Where possible use clamps or a vice to hold the work. It is safer than using your hand.

### 13. **Do not overreach.**

Keep proper footing and balance at all times.

### 14. **Maintain tool with care.**

Keep cutting tools sharp and clean for better and safer performance. Follow instructions for lubrication and changing accessories. Inspect tool cord periodically and if damaged have them replaced by an authorised service facility. Inspect extension cords periodically and replace if damaged. Keep handles dry, clean and free of oil or grease.

### **15. Disconnect tools.**

When not in use, before servicing and when changing accessories such as blades, bits and cutters, disconnect tools from the power supply.

### **16. Remove adjusting keys and wrenches.**

From the habit of checking to see that keys and adjusting wrenches are removed from the tool before turning it on.

### **17. Avoid unintentional starting.**

Ensure switch is in the "off" when plugging in.

### **18. Use outdoor extension leads.**

When tool is used outdoors, use only extension cords intended for outdoor use and so marked.

### **19. Stay alert.**

Watch what you are doing. Use common sense. Do not operate tool when you are tired.

### **20. Check damaged parts.**

Before further use of the tool, it should be carefully checked to determine that it will operate properly and perform its intended function. Check for alignment of moving parts, binding of moving parts, breakage of parts, mounting and any other conditions that may affect its operation. A guard or other part that is damaged should be properly repaired or replaced by an authorised service centre unless otherwise indicated in this instruction manual. Have defective switches replaced by an authorised service facility. Do not use the tool if the switch does not turn it on and off.

### **21. Warning.**

The using of any accessory or attachment other than those recommended in this instruction manual may present a risk of personal injury.

### **22. Have your tools repaired by qualified person.**

This electrical tool complies with the relevant safety requirements. Repairs should only be carried out by qualified persons using original spare parts, otherwise this may result in considerable danger to the user.

## **HEALTH ADVICE**



**WARNING!** When drilling, sanding, sawing or grinding, dust particles will be produced. In some instances, depending on the materials you are working with, this dust can be particularly harmful to you (e.g. lead from old gloss paint).

You are advised to consider the risks associated with the materials you are working with and to reduce the risk of exposure. You should:

-- Work in a well-ventilated area.

-- Work with approved safety equipment, such as those dust masks that are specially designed to filter microscopic particles.

# ADDITIONAL SAFETY INSTRUCTIONS FOR YOUR SCROLL SAWS

## 1. **Never stand on your scroll saw.**

Standing on your Scroll Saw or its stand could cause serious injury and damage to the machine. Do not store materials above or near the tool so that it is necessary to stand on the tool or its stands to reach them.

## 2. **Check damaged parts.**

If any part of the Scroll Saw is damaged, before further use, check carefully that it will operate properly and perform its intended operation. Any guard or other part that is damaged should be correctly repaired or replaced.

## 3. **Safe working practices.**

Never operate the scroll Saw if taking medication that can cause drowsiness or when having consumed alcohol or drugs. It is recommended that the Scroll saw be bolted to a bench with sufficient working space around it.

## 4. **Do not leave the scroll saw running unattended.**

Turn off power to machine and unplug mains cable. Do not stop the machine with work still in contact with the blade.

## 5. **General description**

The Scroll Saw is a static indoor machine not suitable for use outdoor. The machine uses a single-phase alternating current 230V~50Hz motor. Do not attempt to cut pieces of material too small to hold by hand outside the blade guard. Avoid awkward hand positions where a sudden slip could cause a hand to move into the blade.

Avoid the risk of the workpiece jumping upwards, ensure the blade teeth point downward toward the table.

To avoid blade breakage always adjust blade tension correctly.

## 6. **To avoid losing control of the work piece or tool:**

When cutting a large piece of material make sure it is fully supported at table height. Hold the work piece firmly against the table. Do not force the material while cutting. Only feed the material fast enough so that the blade maintains a smooth cutting speed. Use caution when cutting off material which is irregular in cross section, which could pinch the blade before the cut is completed. A piece of moulding for example must lay on the table and not be permitted to rock while being cut. Use caution when cutting off round material such as dowel rods or tubing. They have a tendency to roll while being cut causing the blade to bite. Use a Vblock to control the piece. When backing the blade out of the workpiece, the blade may bind in the kerf (cut) this is usually caused by sawdust clogging up the kerf. If this happens, turn off the Scroll Saw, remove plug from power source outlet, wedge open the kerf, and then back the blade out of the workpiece. To avoid misuse or accidents due to inattention, never leave the scroll saw work area with the power on or before the machine has come to a complete stop.

Do not perform layout, assembly or set up work on the table while saw is in operation. Turn the saw off and remove plug from power supply before installing or removing an accessory or attachment. Never turn your scroll saw on before clearing the table of all objects (tools scraps of wood etc).

## 7. **Damaged or missing parts.**

Should any part of this Scroll Saw be missing, bent or fail in any way or any electrical component fail to perform properly, shut off the power switch and

remove the plug from power supply.

Replace damaged, missing and/or failed parts before resuming operation.

### **8. Think safety.**

Safety is a combination of operator common sense and alertness whenever the scroll saw is in operation. The operation of any power tool can result in foreign objects being thrown in to the eyes, which can result in severe eye damage.

Always wear safety goggles before commencing power tool operation.

### **Warning:**

 Always wear safety goggles or face shield. Install blade with teeth pointing down towards the table. Keep fingers a safe distance from the blade.

Never leave the scroll saw work area with the power on. Adjust blade tension by hand (not with a tool) before turning on. Maintain control of the workpiece at all times, hold firmly against the table.

## **SYMBOLS**



Read the manual



Warning



Wear gloves



Wear dust mask, eye & ear protection



Conforms to relevant safety standards

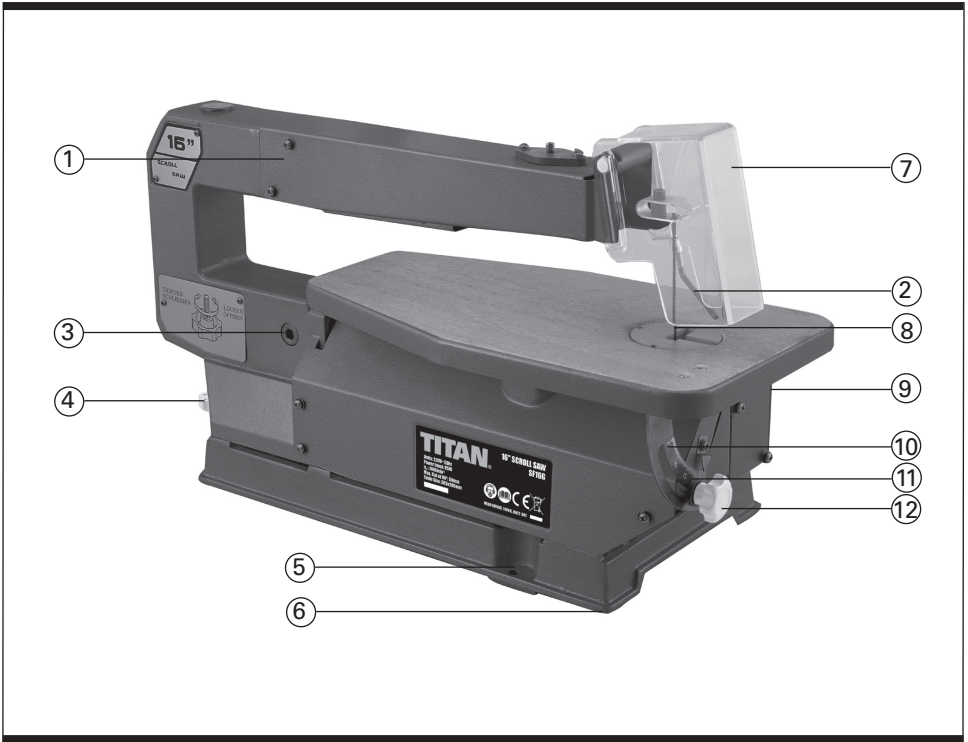

---

**1. FRAME**

---

**2. DUST BLOWER**

---

**3. ARM BEARING (ON EACH SIDE)**

---

**4. TENSION KNOB**

---

**5. BENCH MOUNTING HOLES**

---

**6. BASE**

---

**7. BLADE GUIDE**

---

**8. BLADE**

---

**9. ON/OFF SWITCH**

---

**10. BEVEL SCALE**

---

**11. BEVEL SCALE POINTER**

---

**12. TABLE LOCKING KNOB**

---

**16" SCROLL SAW**

**SF16G**

## TECHNICAL DATA

Voltage:	230V~50Hz
Input power:	85W
No load speed:	1,400min <sup>-1</sup>
Max. Width of cut:	406mm
Blade size:	128mm length
	25 teeth / inch
Max. Depth of cut:	50mm at 90°
Max. Depth of cut:	25mm at 45°
Table size:	365x200 mm
Weight:	14.9Kg

## NOISE AND VIBRATION DATA

A weight sound pressure	66.4dB(A)
A weighted sound power	79.4dB (A)
Noise and Vibration	2.598m/s <sup>2</sup>

## ACCESSORIES

**Blade**

**1 PC**



# ASSEMBLY OF THE SCROLL SAW

**Warning:** For your own safety never connect plug to power source until all assembly steps are complete.

**Caution:** Never lift this saw by the arm, which holds the blade or damage will occur to your saw.

Locate the blade guard and carefully install it onto the saw as shown. (See Fig2) Secure the blade guard to the frame by a bolt, washer and knob. Your scroll saw is fitted with a small blow pump to help keep the blade and work area clean. Insert pipe onto blower, point outlet pipe towards blade.

## Setting the table for horizontal or bevel cutting

The Scroll Saw worktable can be tilted to the left for bevel cutting up to 45° from 0° or horizontal position. (See Fig3)

A bevel scale is provided under the worktables as a convenient reference for setting the approximate table angle for bevel cutting. When greater precision is required, make practice cuts and adjust the table as necessary for your requirements.

## To align the bevel indicator

Loosen the table locking knob and move the table until it is approximately perpendicular or at a right angle to the blade. (See Fig4)

Use a small set square to set the table at 90 degrees to the blade. When the space between the set square and the blade is minimal, tighten the bevel locking knob. The table should now be approximately 90 degrees to the blade. (See Fig5)

Loosen the screw holding the bevel scale pointer and adjust pointer to 0 degrees. Tighten screw. Remember the bevel scale is a convenient guide but should not be relied upon for precision. Make practice cuts in scrap wood to determine if your angle settings are correct. Adjust the table as required.

## Removing and installing blades

**Warning:** To avoid injury from accidental starting, always turn switch "off" and remove the plug from electrical outlet

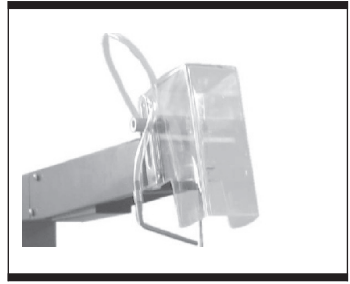

Fig 2

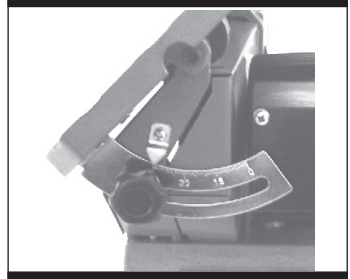

Fig 3

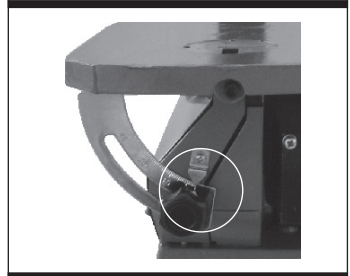

Fig 4

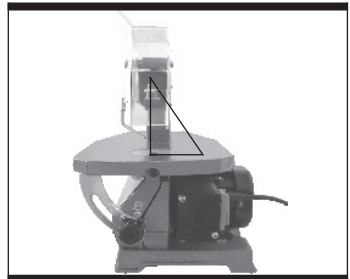
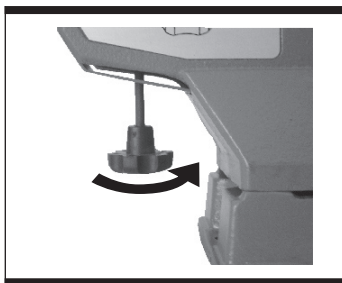
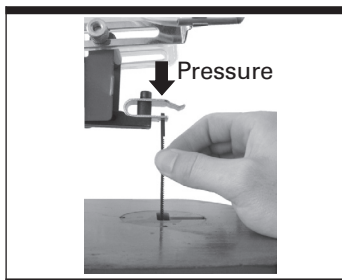

Fig 5



**Fig 6**



**Fig 7**

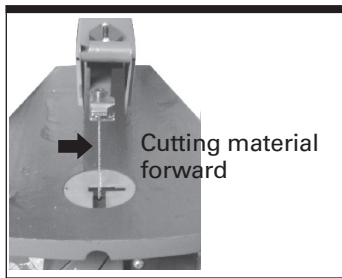

**Fig 8**

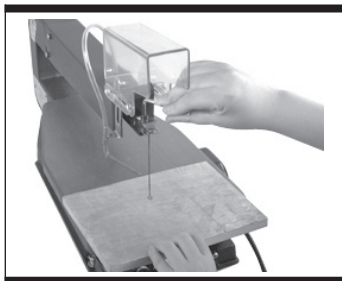

**Fig 9**

### **before removing or replacing the blade.**

Loosen tension on the blade by turning tension knob check just until the tension spring is fully compressed. (See Fig6) Remove blade by pulling forward on blade and then lifting the blade through the access hole in the table.

Slight downward pressure against the upper arm may be helpful when removing blade from upper holder. (See Fig7) Look at the blade holders closely and notice the blade slots and pin recesses in the blade holder. The blade holder is made so you can position the blade for cutting from the front or from the side of the saw. Cutting from the side of the saw will be necessary when your work piece exceeds 406mm (16 inch) in length. With the blade positioned for side cutting the table must always remain in the 0 degrees bevel position. (See Fig8)

**⚠ Warning: Do not attempt to cut a bevel with the blade positioned for side cutting.**

### **Mounting the scroll saw to a bench**

This saw must be mounted on a solid non moving surface ie a heavy duty bench by means of suitable bolts(not supplied).We also recommend using a soft foam pad between the saw and the work surface(not provided) which will greatly reduce noise and vibration.

### **Do not over tighten mounting bolts**

Leave some cushion in the foam pad for absorbing noise and vibration.

To turn the machine on push the green button marked "I";To turn the machine off, push in the red button marked "0".

### **Note:**

Never leave the machine unattended until it has come to a complete stop. Your machine has been fitted with the latest type of safety switch and will automatically switch to the off position when the machine is disconnected from the power supply.

# OPERATION

## **Please read and understand the following guidelines for your scroll saw before attempting to use it:**

There is a skill level associated with using a Scroll saw. Until you have practiced with the saw and built up your skill level, be prepared for the possibility that you might snap the blades. Following these simple guidelines will help you achieve best results from your saw:

- a) Do not aggressively push wood onto the blade. Adopt a “feeding” motion and allow the saw to cut the wood by guiding it onto the blade. Remember the blade cuts on the down stroke only.
- b) Best results are achieved when cutting wood less than 25mm thick. When cutting wood thicker than this feed the wood slowly onto the blade and be careful not to bend or twist the blade.
- c) Replace your blade when it becomes blunt.
- d) Be prepared to compensate for the blade tendency to follow the grain of the wood.
- e) As a guide to blade selection very fine narrow blades should be used to cut in thin wood (6mm). For wider timber use wider blades. Check the instructions that come with the blades for guidance.
- f) As a general guide wider blades will not cut curves as accurate as a narrow blade.
- g) Do not apply side pressure to the blade
- h) Blades will wear quicker when cutting plywood or timber over 25mm thick.

### **Making interior scroll cuts**

One of the features of this saw is that it can be used to make scroll cuts on the interior of a board without breaking or cutting into the outline or perimeter of the board.

 **Warning: To avoid injury from accidental starting, always turn switch**

**off and remove the plug before removing or replacing the blade.**

To make interior cuts in a board remove the scroll saw blade as explained in the assembly section. Drill a 6mm (1/4") hole in the board you will use to make interior cuts. Place the board on the saw table with the hole in the board over the access hole in the table. Install blade through hole in the board, re-attach blade to blade holders and adjust blade tension. (See Fig9) When finished making the interior scroll cuts simply remove the blade from the blade holders as described in the assembly section and remove the board from the table.

## TROUBLE SHOOTING



### Warning:

**For your own safety, turn switch "off" and remove the plug before trouble shooting your scroll saw.**

<b>Problem</b>	<b>Problem cause</b>	<b>Remedy suggested</b>
Breaking blades	<ol style="list-style-type: none"><li>1. Wrong tension.</li><li>2. Over working blade.</li><li>3. Wrong blade application.</li><li>4. Twisting blade in wood.</li></ol>	<ol style="list-style-type: none"><li>1. Adjust blade tension.</li><li>2. Reduce feed rate.</li><li>3. Use narrow blades for cutting thin wood, wide blades for thicker wood.</li><li>4. Avoid side pressure.</li></ol>
Motor will not run	<ol style="list-style-type: none"><li>1. Defective cable or plug.</li><li>2. Defective motor.</li></ol>	<ol style="list-style-type: none"><li>1. Replace parts before using saw again.</li><li>2. Consult a service centre.</li></ol> <p>Any attempt to repair this motor may create a HAZARD unless a qualified service technician does repair.</p>
Vibration Note: There will always be some vibration present when the saw is running because of the motor operation.	<ol style="list-style-type: none"><li>1. Improper mounting of saw.</li><li>2. Unsuitable mounting surface.</li><li>3. Loose table or table resting against motor.</li><li>4. Loose motor mounting.</li></ol>	<ol style="list-style-type: none"><li>1. See mounting instructions in this manual for proper mounting technique.</li><li>2. The heavier your workbench is the less vibration will occur. A plywood workbench will not be as good as solid timber bench. Use common sense in choosing a mounting surface.</li><li>3. Tighten table lock knob.</li><li>4. Tighten motor mounting screws.</li></ol>
Blades run out. Blades not in-line with arm motion.	<ol style="list-style-type: none"><li>1. Blade holders not aligned.</li></ol>	<ol style="list-style-type: none"><li>1. Loosen cap screws holding blade holders to adjust position of blade holder - retighten holders.</li></ol>

## MAINTENANCE

**Warning:** For your own safety turn switch off and remove the plug before maintaining or lubricating your saw.

### **General:**

An occasional coat of paste wax on the worktable will allow the wood being cut to glide smoothly across the work surface.

### **Motor:**

If the power cable is worn, cut or damaged in any way, have it replaced immediately. DO NOT attempt to oil the motor bearings or service the motor internal parts.

### **Arm bearings:**

Lubricate the arm bearings after every 50 hours of use.

To do so: Turn saw on its side.

Squirt a generous amount of SAE 20 oil around the shaft end and bronze bearing.

Let the oil soak in overnight in this condition.

Next day repeat the above procedure for the opposite side of the saw.

## ENVIRONMENTAL PROTECTION



Waste electrical products should not be disposed of with household waste. Please recycle where facilities exist. Check with your Local Authority or retailer for recycling advice.

# PLUG REPLACEMENT

The fuse in the main plug on the charger should always be replaced with one of identical rating.

Check the voltage given on the charger matches the supply voltage.

The fast charger include with you drill is supplied with a fitted plug, however if you should need to fit a new plug follow the instruction below.

## IMPORTANT

The wire in the mains lead are coloured in accordance with the following code:

**Green & yellow ---Earth**

**Blue ---Neutral**

**Brown ---Live**

The wire which is coloured green & yellow must be connected to the terminal which is marked with E or  $\overline{\text{E}}$ .

The wire that is coloured blue must be connected to the terminal that is marked with the letter N.

The wire that is coloured brown must be connected to the terminal that is marked with the letter L.

A 13AMP (BS1363 or BS1363/A) plug must be used and a 5 AMP fuse must be fitted.

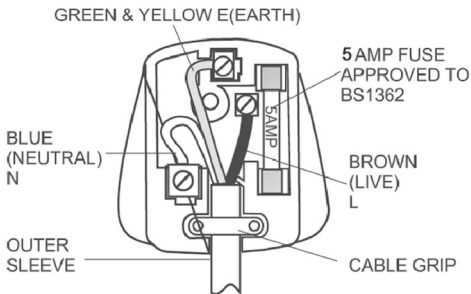



## Declaration of Conformity

We, Importer

**Screwfix Direct Ltd**

**Mead Avenue**

**Houndstone Business Park**

**Yeovil**

**BA 22 8RT**

Declare that the product

**SCROLL SAW**

**SF16G**

Complies with the essential health and safety requirements of the following directives:

**89/336/EEC, 93/68/EEC** – EMC Directive.

**73/23/EEC, 93/68/EEC** – Low Voltage Directive.

**98/37/EC** – Machinery Directive.

Standards and technical specifications referred to:

**EN 61029-1/A12:2003**

**EN 55014-1 /A2:2002**

**EN 55014-2 /A1:2001**

**EN 61000-3-2:2000**

**EN 61000-3-3: /A1:2001**

### Authorised Signatory

Date: 15/09/05

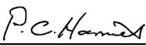
Signature: 

Name: Peter Harries  
Screwfix Direct Ltd  
Quality Manager





**TITAN<sup>®</sup>**

**16" SCROLL SAW**

**SF16G**