

Worktop Jig 700 & 900

Instructions Leaflet

WORKTOP JIG 700

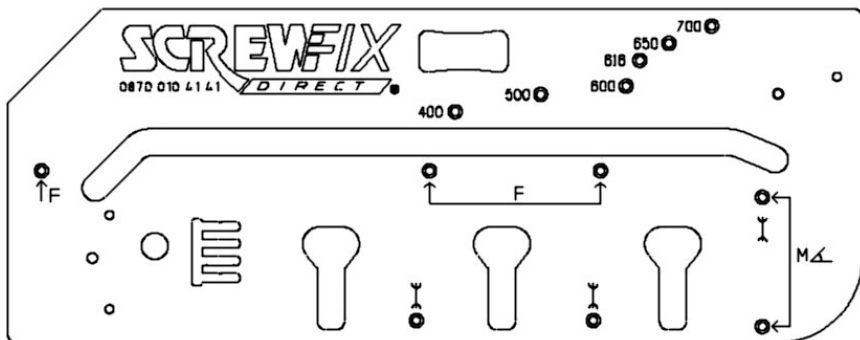

- ◆ FOR RIGHT AND LEFT STANDARD 90° AND 45° JOINTS
- ◆ FOR RECESSES FOR WORKTOP CONNECTING BOLT
- ◆ CUTS WORKTOPS FROM 400MM TO 700MM WIDE
- ◆ EASY TO FOLLOW SYMBOLS
- ◆ CONVENIENT CARRYING HANDLE
- ◆ SNAP IN HOLDER FOR LOCATION PEGS
- ◆ 30MM ROUTER BUSHING HOLDER

WORKTOP JIG 900

- ◆ FOR RIGHT AND LEFT STANDARD 90° AND 45° JOINTS
- ◆ FOR RECESSES FOR WORKTOP CONNECTING BOLT
- ◆ CUTS WORKTOPS FROM 400MM TO 700MM WIDE
- ◆ EASY TO FOLLOW SYMBOLS
- ◆ 30MM ROUTER BUSHING HOLDER

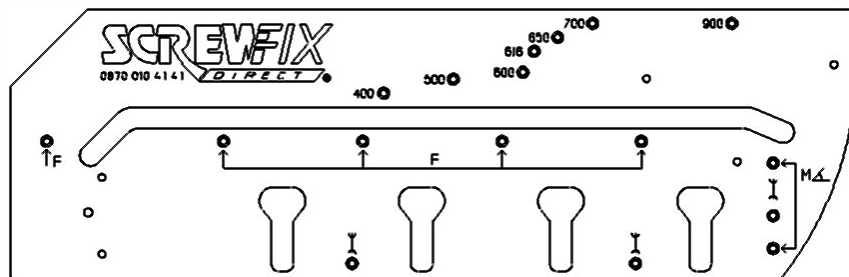

ADDITIONAL EQUIPMENT REQUIRED:

- HAND ROUTER
- 30mm ROUTER GUIDE BUSH
- TUNGSTEN CARBIDE ROUTER CUTTER - 12.7mm DIA X 50mm (1/2" DIA X 2")
- MINIMUM OF 2 QUICK ACTION OR 'G' CLAMPS

Before Starting

ALWAYS

- make sure the worktop laminate is secured firmly to the bench or trestle.
- ensure that the jig is firmly secured to the worktop laminate.
- there are no obstructions in the path of the router e.g. clamps or bench.
- use good quality sharp tungsten router bits
- wear eye protection when cutting.
- cut from left to right.
- cut into post formed edge to avoid breakout or chipping.
- keep the router vertical to the jig and laminate.

NEVER

- cut worktop to length until all joints are complete and have been checked for correct fit.
- exceed 10mm depth of cut in one pass.
- remove the router from the jig or position the router whilst cutter is still rotating. The cutter may cut into the jig and damage the bush location faces. (Returns will not be accepted if this has occurred).

STANDARD 90° JOINT
- LEFT HAND

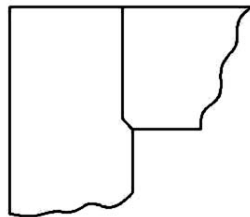

STANDARD 90° JOINT
- RIGHT HAND

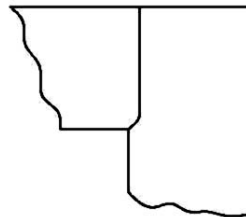

45° JOINT- RIGHT HAND

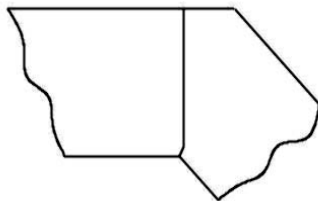

45° JOINT- LEFT HAND

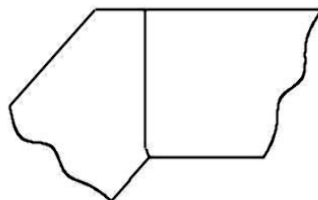

CORNER JOINT -
USING THE RIGHT
HAND AND LEFT
HAND 45° JOINTS

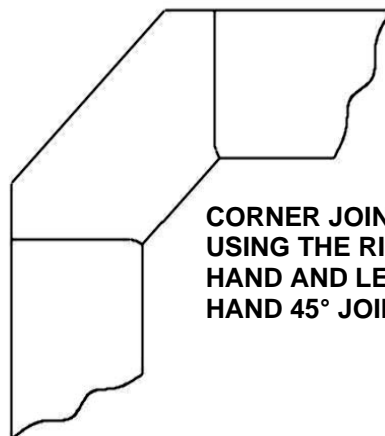

Before Startingcont:-

IMPORTANT NOTE:

On the front face of the Jig are two holes which are partially drilled through - they are indicated below.

Do not drill these through! Do not use them to locate the jig when cutting!

They have been added for production purposes only and should not be used for positioning or orienting the jig.

No returns will be accepted if these holes are changed or used in anyway

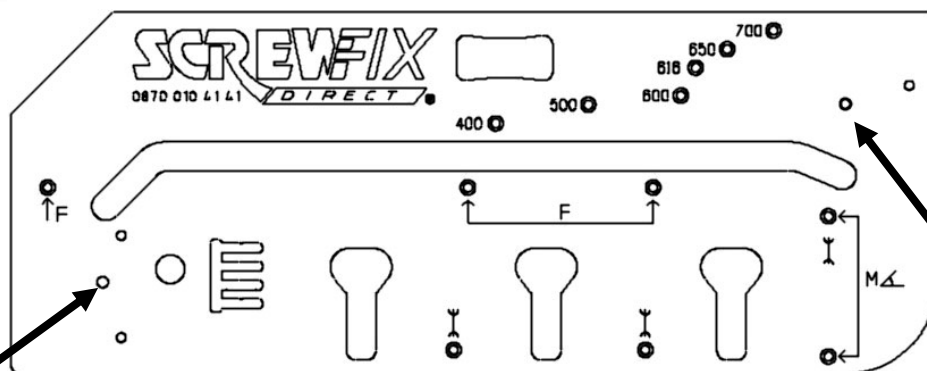

DO NOT USE!

DO NOT USE!

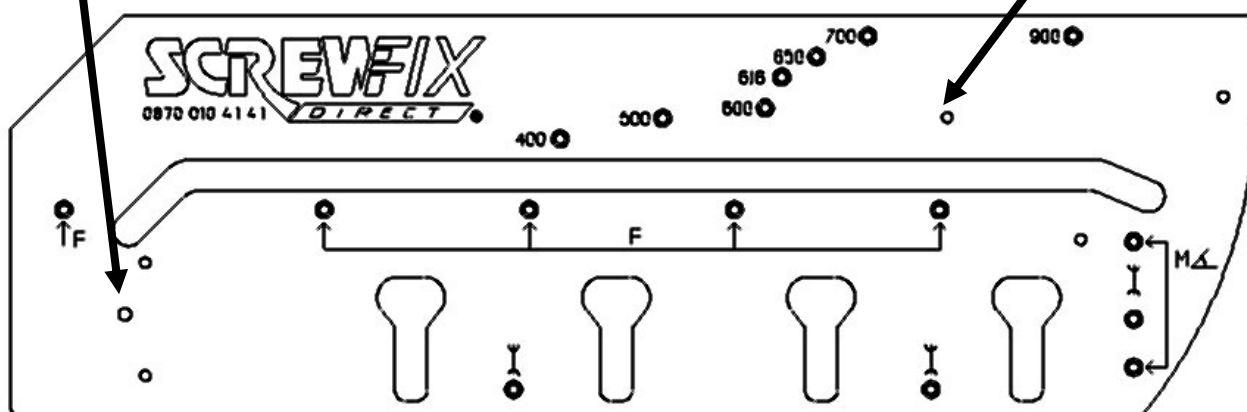

SCREWFIX

0870 010 41 41 / DIRECT®

Screwfix Direct Ltd
Mead Avenue
Houndstone
Business Park
Yeovil
BA22 8RT

- FEMALE JOINT** Refer to the diagrams on the different joints available. Prepare the female worktop with the laminate face up and the post formed (curved edge) towards you.
- Insert three pins in the holes marked **F**.
- Insert the 4th pin in the hole dependant on your worktop width. E.g. If your worktop is 600mm wide then insert the 4th pin in the hole marked 600 (see diagram A).
- Make sure the 3 pins in the holes marked with F are firmly pushed against the front post formed edge and the pin in the hole marked with the worktop width is pushed firmly against the edge of the worktop (see diagram A)
- Clamp the jig to the worktop checking that all 4 pins are still against the worktop. Make sure the clamps will not obstruct the router path.
- CUTTING** Position the router in the far left side of the central slot. Set the router to cut a depth of 10mm.
- IMPORTANT - Position the router in the slot and cut from left to right, pulling the router against the edge of the slot closest to you.**
- Remove the router, and start again from the far left of the central slot, but increase the depth a further 10mm.
- Follow steps 7 – 8, until cut is complete.
- For the final finishing cut, position the router again in the far left side of the central slot, and set the router to cut at the full depth of the worktop. Again, cut from left to right but apply the pressure to the edge furthest away from you.
- MALE JOINT** Prepare the male worktop with the laminate face down.
- Insert 2 pins in holes marked **M**.
- Refer to the page on 'cutting to length' to find out where to mark the pencil line to determine the position of the jig along the length of the worktop.
- Make sure the 2 pins in the holes marked M are firmly pushed against the post formed edge (see diagram B)
- Clamp the jig to the worktop checking that both pins are still against the worktop. Make sure the clamps will not obstruct the router path.
- Follow steps 6 to 10 for cutting the worktop.

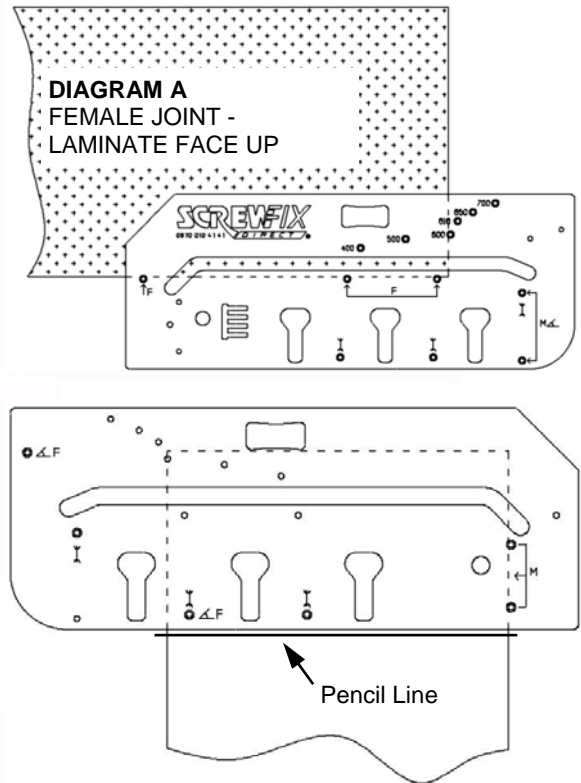

DIAGRAM B
MALE JOINT—LAMINATE FACE DOWN

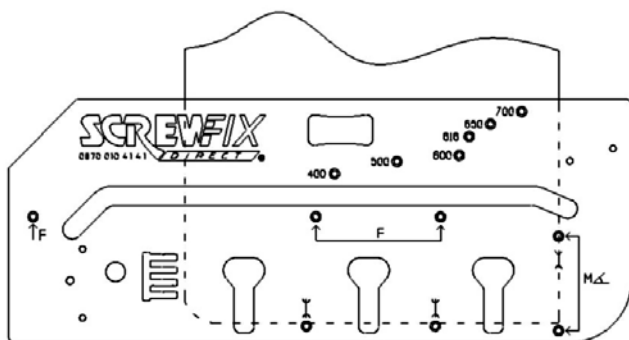
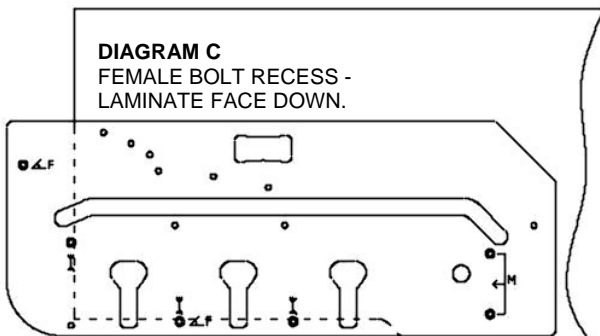

DIAGRAM D
MALE BOLT RECESS—LAMINATE FACE DOWN.

- FEMALE BOLT RECESSES** Prepare the female worktop with the laminate face down.
- Insert 3 pins in the holes which have a symbol resembling a worktop connector (see diagram C).
- Make sure the 3 pins are firmly pushed against the front cut out and the edge of the worktop (see diagram C).
- Clamp the jig to the worktop checking that all 3 pins are still firmly against the worktop. Make sure the clamps will not obstruct the router path.
- You will need a depth of 20mm for the worktop connectors. Do not exceed 10mm per cut.
- Cut the bolt recesses out, each time clearing the waste material after each cut.
- MALE BOLT RECESSES** Prepare the male worktop with the laminate face down.
- Insert 3 pins in the holes which have a symbol resembling a worktop connector (see diagram D).
- Make sure the 3 pins are firmly pushed against the front cut out and the edge of the worktop (see diagram D).
- Clamp the jig to the worktop checking that all 3 pins are still firmly against the worktop. Make sure the clamps will not obstruct the router path.
- You will need a depth of 20mm for the worktop connectors. Do not exceed 10mm per cut.
- Cut the bolt recesses out, each time clearing the waste material after each cut.

Right Hand 90° Joints

- FEMALE JOINT** Refer to the diagrams on the different joints available. Prepare the female worktop with the laminate face down and the post formed (curved edge) towards you.
- Insert three pins in the holes marked **F**.
- Insert the 4th pin in the hole dependant on your worktop width, e.g. If your worktop is 600mm wide then insert the 4th pin in the hole marked 600 (see diagram A).
- Make sure the 3 pins in the holes marked **F** are firmly pushed against the front post formed edge and the pin in the hole marked with the worktop width is pushed firmly against the edge of the worktop (see diagram A)
- Clamp the jig to the worktop double-checking that all 4 pins are still against the worktop. Make sure the clamps will not obstruct the router path.
- CUTTING** Position the router in the far left side of the central slot. Set the router to cut a depth of 10mm.
- IMPORTANT - Position the router in the slot and cut from left to right, pulling the router against the edge of the slot closest to you.**
- Remove the router, and start again from the far left of the central slot, but increase the depth a further 10mm.
- Follow steps 7 – 8, until cut is complete.
- For the final finishing cut, position the router again in the far left side of the central slot, and set the router to cut at the full depth of the worktop. Again, cut from left to right but apply the pressure to the edge furthest away from you.
- MALE JOINT** Prepare the male worktop with the laminate face up.
- Insert 2 pins in holes marked **M**.
- Refer to the page on 'cutting to length' to find out where to mark the pencil line to determine the position of the jig along the length of the worktop.
- Make sure the 2 pins in the holes marked **M** are firmly pushed against the post formed edge (see diagram B)
- Clamp the jig to the worktop checking that both pins are still against the worktop.
- Make sure the clamps will not obstruct the router path.
- Follow steps 6 to 10 for cutting the worktop.

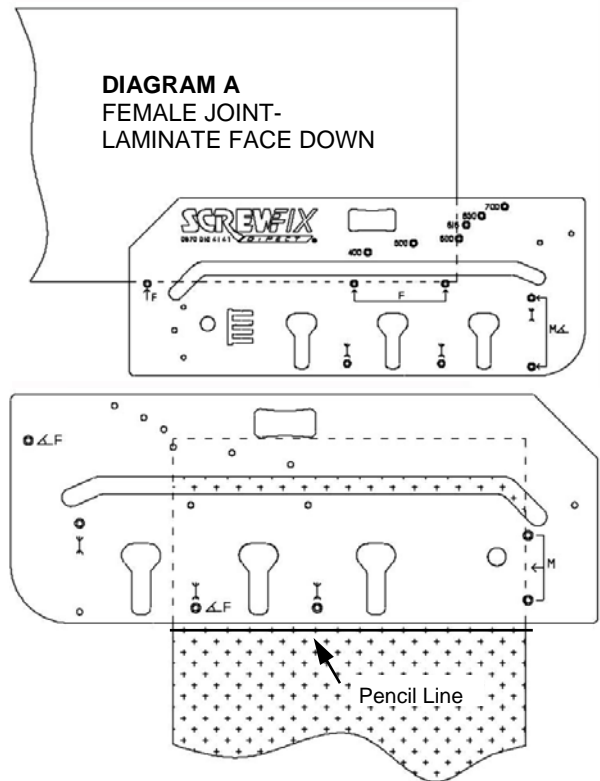

DIAGRAM B
MALE JOINT- LAMINATE FACE UP

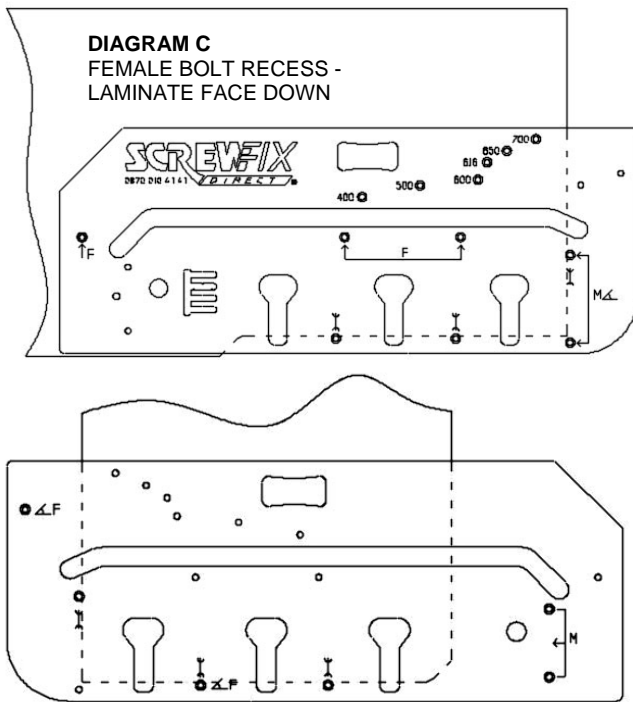
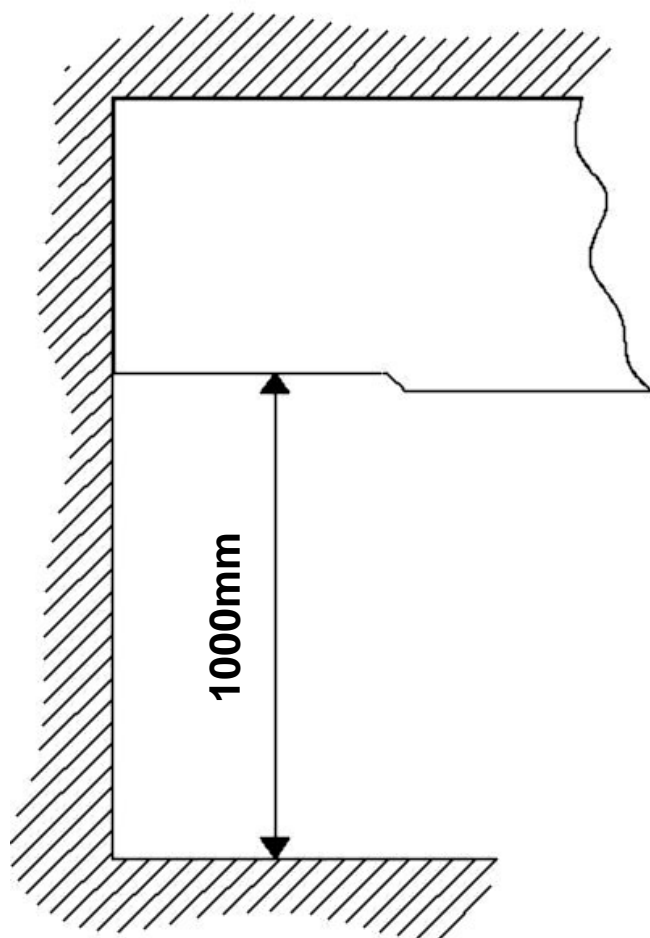

DIAGRAM D
MALE BOLT RECESS - LAMINATE FACE DOWN

- FEMALE BOLT RECESSES** Prepare the female worktop with the laminate face down.
- Insert 3 pins in the holes which have a symbol resembling a worktop connector (see diagram C).
- Make sure the 3 pins are firmly pushed against the front cut out and the edge of the worktop (see diagram C).
- Clamp the jig to the worktop checking that all 3 pins are still firmly against the worktop. Make sure the clamps will not obstruct the router path.
- You will need a depth of 20mm for the worktop connectors. Do not exceed 10mm per cut.
- Cut the bolt recesses out, each time clearing the waste material after each cut.
- MALE BOLT RECESSES** Prepare the male worktop with the laminate face down.
- Insert 3 pins in the holes which have a symbol resembling a worktop connector (see diagram D).
- Make sure the 3 pins are firmly pushed against the front cut out and the edge of the worktop (see diagram D).
- Clamp the jig to the worktop checking that all 3 pins are still firmly against the worktop. Make sure the clamps will not obstruct the router path.
- You will need a depth of 20mm for the worktop connectors. Do not exceed 10mm per cut.
- Cut the bolt recesses out, each time clearing the waste material after each cut.

Cutting to Length



When producing a male joint, left or right hand, the position of the worktop jig has to be calculated. It is easier if the female joint is cut first, leaving the gap intended for the male part of the worktop.

Example

The female joint has already been cut (see left diagram) and the length of the male worktop needed is 1000mm (1 metre).

Position your worktop jig onto the laminate referring back to the instructions on 90° joints.

Subtract 228mm from the intended length
E.g. $1000\text{mm} - 228 = 772\text{mm}$

Position the worktop jig 772mm from the opposite end of the laminate you're cutting (see bottom left diagram)

After the cut, a 1000mm length laminate is left.

Change the 1000mm figure used in this example for whatever length you require.

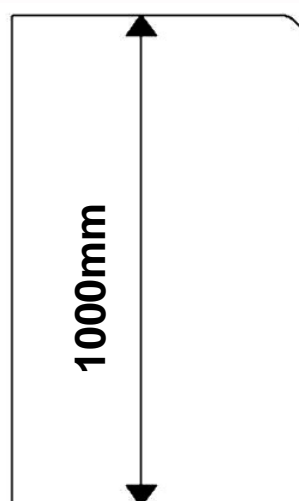
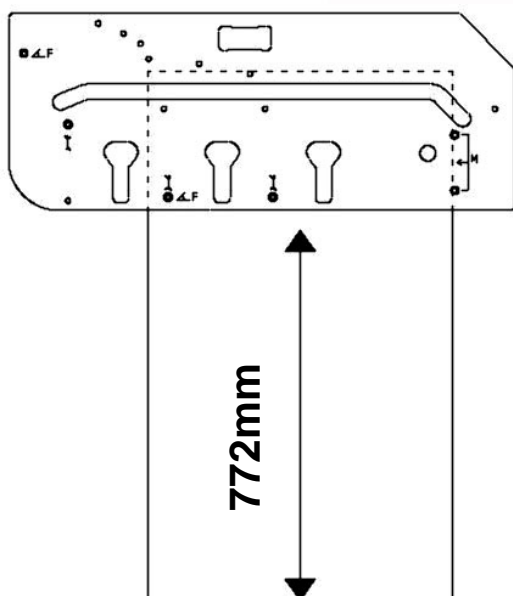

SCREWFIX

0870 010 41 41 / DIRECT®

Screwfix Direct Ltd
Mead Avenue
Houndstone
Business Park
Yeovil
BA22 8RT

Left Hand 45° Joints

1. **FEMALE JOINT** Refer to the diagrams on the different joints available. Prepare the female worktop with the laminate face up and the post formed (curved edge) towards the left.
2. Insert 2 pins in the holes marked **F** with a symbol resembling an **ANGLE**.
3. Slide the jig along the length of the worktop, once the jointing face has been cut, there will be enough length for the male worktop to fit (minor adjustment may be necessary) see diagram B)
4. Make sure the 2 pins in the holes marked **F ANGLE** are firmly pushed against the front post formed edge (see diagram A)
5. Clamp the jig to the worktop checking that both pins are still against the worktop. Make sure the clamps will not obstruct the router path.
6. Once the cut is complete, cut off the excess (Diagram B), so that the distance from point 1 to point 2 is equal to your worktop width.
7. **CUTTING** Position the router in the far left side of the central slot. Set the router to cut a depth of 10mm.
8. **IMPORTANT - Position the router in the slot and cut from left to right, pulling the router against the edge of the slot closest to you.**
9. Remove the router, and start again from the far left of the central slot, but increase the depth a further 10mm.
10. Follow steps 7 – 8, until cut is complete.
11. For the final finishing cut, position the router again in the far left side of the central slot, and set the router to cut at the full depth of the worktop. Again, cut from left to right but apply the pressure to the edge furthest away from you.
12. **MALE JOINT** Prepare the male worktop with the laminate face down.
13. Insert 2 pins in holes marked **M** with a symbol resembling an **ANGLE**.
14. Refer to the page on 'cutting to length' to find out where to mark the pencil line to determine the position of the jig along the length of the worktop.
15. Make sure the 2 pins in the holes marked **M ANGLE** are firmly pushed against the post formed edge (see diagram C)
16. Clamp the jig to the worktop checking that both pins are still against the worktop. Make sure the clamps will not obstruct the router path.
17. Follow steps 6 to 10 for cutting the worktop.
18. **FEMALE BOLT RECESSES** Prepare the female worktop with the laminate face down.
19. Insert 3 pins in the holes which have a symbol resembling a worktop connector (see diagram D).
20. Make sure the 3 pins are firmly pushed against the front cut out and the edge of the worktop (see diagram D).
21. Clamp the jig to the worktop checking that all 3 pins are still firmly against the worktop. Make sure the clamps will not obstruct the router path.
22. You will need a depth of 20mm for the worktop connectors. Do not exceed 10mm per cut.
22. Cut the bolt recesses out, each time clearing the waste material after each cut.
23. **MALE BOLT RECESSES** Prepare the male worktop with the laminate face down.
24. Insert 3 pins in the holes which have a symbol resembling a worktop connector. Follow instructions on male bolt recesses on the page referring to left hand 90 degree joints.

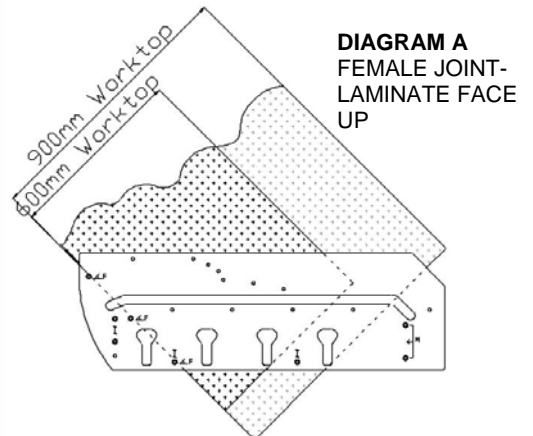

DIAGRAM A
FEMALE JOINT-
LAMINATE FACE
UP

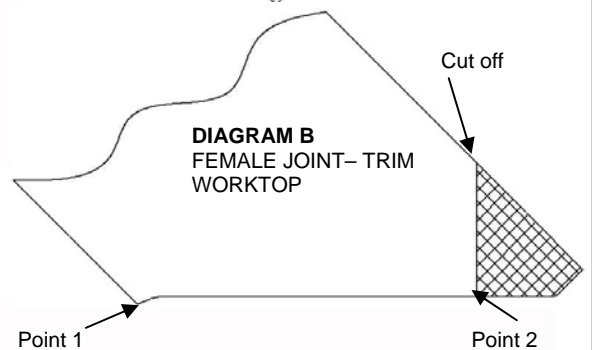

DIAGRAM B
FEMALE JOINT- TRIM
WORKTOP

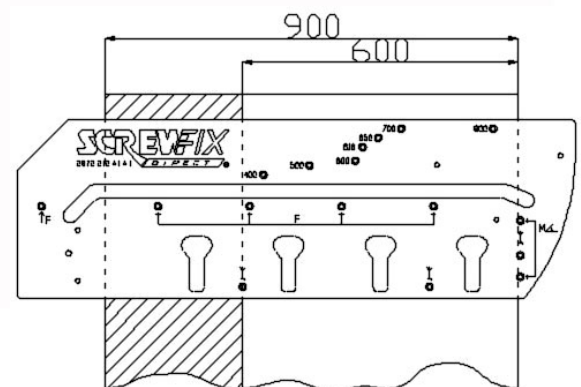

DIAGRAM C
MALE JOINT - LAMINATE FACE DOWN

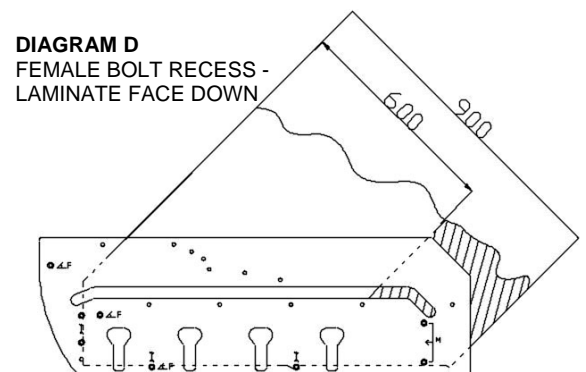

DIAGRAM D
FEMALE BOLT RECESS -
LAMINATE FACE DOWN

Right Hand 45° Joints

- FEMALE JOINT** Refer to the diagrams on the different joints available. Prepare the female worktop with the laminate face down and the post formed (curved edge) towards the left.
- Insert 2 pins in the holes marked F with a symbol resembling an ANGLE.
- Slide the jig along the length of the worktop, once the jointing face has been cut, there will be enough length for the male worktop to fit (minor adjustment may be necessary) see diagram B)
- Make sure the 2 pins in the holes marked F ANGLE are firmly pushed against the front post formed edge (see diagram A)
- Clamp the jig to the worktop checking that both pins are still against the worktop. Make sure the clamps will not obstruct the router path.
- Once the cut is complete, cut off the excess (Diagram B), so that the distance from point 1 to point 2 is equal to your worktop width.
- CUTTING** Position the router in the far left side of the central slot. Set the router to cut a depth of 10mm.
- IMPORTANT - Position the router in the slot and cut from left to right, pulling the router against the edge of the slot closest to you.**
- Remove the router, and start again from the far left of the central slot, but increase the depth a further 10mm.
- Follow steps 7 – 8, until cut is complete.
- For the final finishing cut, position the router again in the far left side of the central slot, and set the router to cut at the full depth of the worktop. Again, cut from left to right but apply the pressure to the edge furthest away from you.
- MALE JOINT** Prepare the male worktop with the laminate face up.
- Insert 2 pins in holes M with a symbol resembling an ANGLE.
- Refer to the page on 'cutting to length' to find out where to mark the pencil line to determine the position of the jig along the length of the worktop.
- Make sure the 2 pins in the holes marked M ANGLE are firmly pushed against the post formed edge (see diagram C)
- Clamp the jig to the worktop checking that both pins are still against the worktop. Make sure the clamps will not obstruct the router path.
- Follow steps 6 to 10 for cutting the worktop.
- FEMALE BOLT RECESSES** Prepare the female worktop with the laminate face down.
- Insert 3 pins in the holes which have a symbol resembling a worktop connector (see diagram D).
- Make sure the 3 pins are firmly pushed against the front cut out and the edge of the worktop (see diagram D).
- Clamp the jig to the worktop checking that all 3 pins are still firmly against the worktop. Make sure the clamps will not obstruct the router path.
- You will need a depth of 20mm for the worktop connectors. Do not exceed 10mm per cut.
- Cut the bolt recesses out, each time clearing the waste material after each cut.
- MALE BOLT RECESSES** Prepare the male worktop with the laminate face down.
- Insert 3 pins in the holes which have a symbol resembling a worktop connector. Follow instructions on male bolt recesses on the page referring to right hand 90 degree joints.

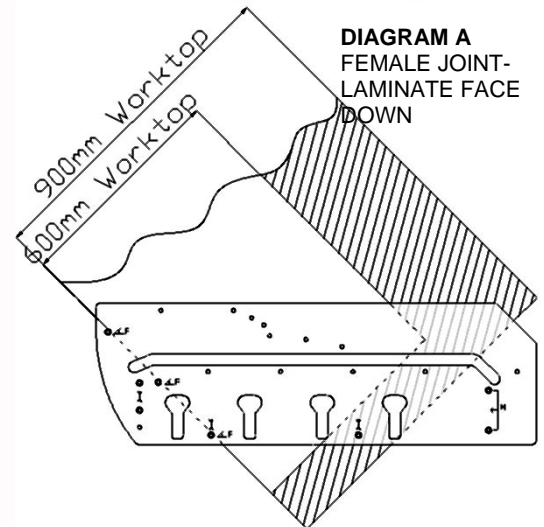

DIAGRAM A
FEMALE JOINT-
LAMINATE FACE
DOWN

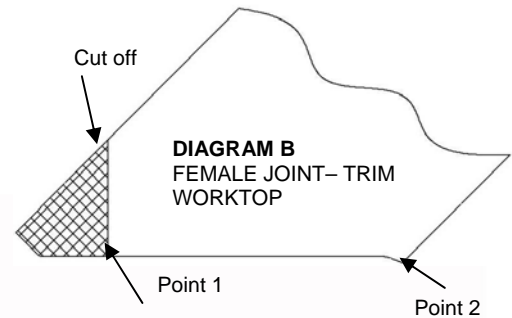

DIAGRAM B
FEMALE JOINT- TRIM
WORKTOP

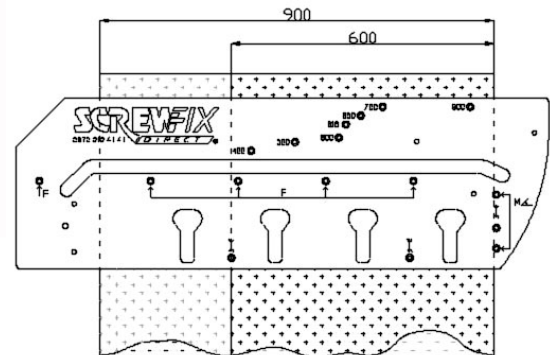

DIAGRAM C
MALE JOINT - LAMINATE FACE UP

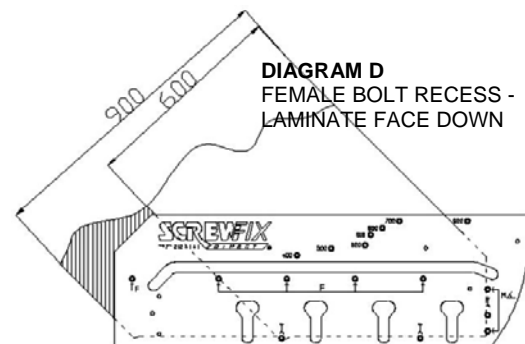

DIAGRAM D
FEMALE BOLT RECESS -
LAMINATE FACE DOWN