

Bedienungsanleitung
Operating Instructions
Instructions d'emploi
Instrucciones de servicio
Manual de instruções
Istruzioni d'uso
Gebruiksaanwijzing
Betjeningsvejledning
Bruksanvisning
Brukerveiledningen
Käyttöohje
Οδηγία χειρισμού
Kullanım kılavuzu

BOSCH

GHO 26-82

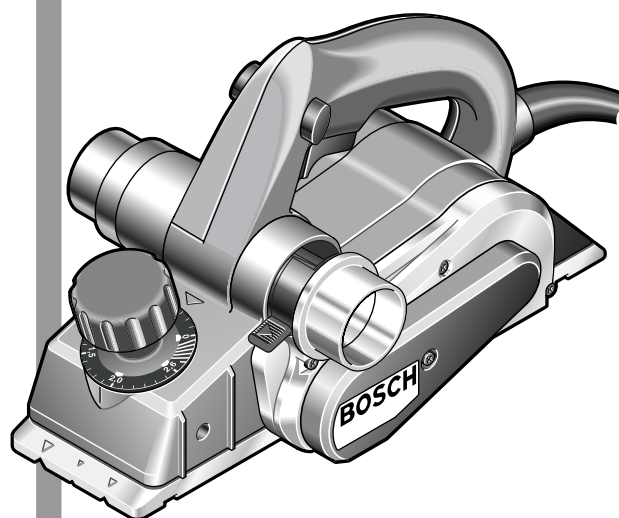

Deutsch
English
Français
Español
Português
Italiano
Nederlands
Dansk
Svenska
Norsk
Suomi
Ελληνικά
Türkçe



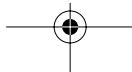
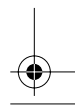
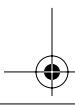
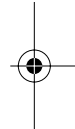
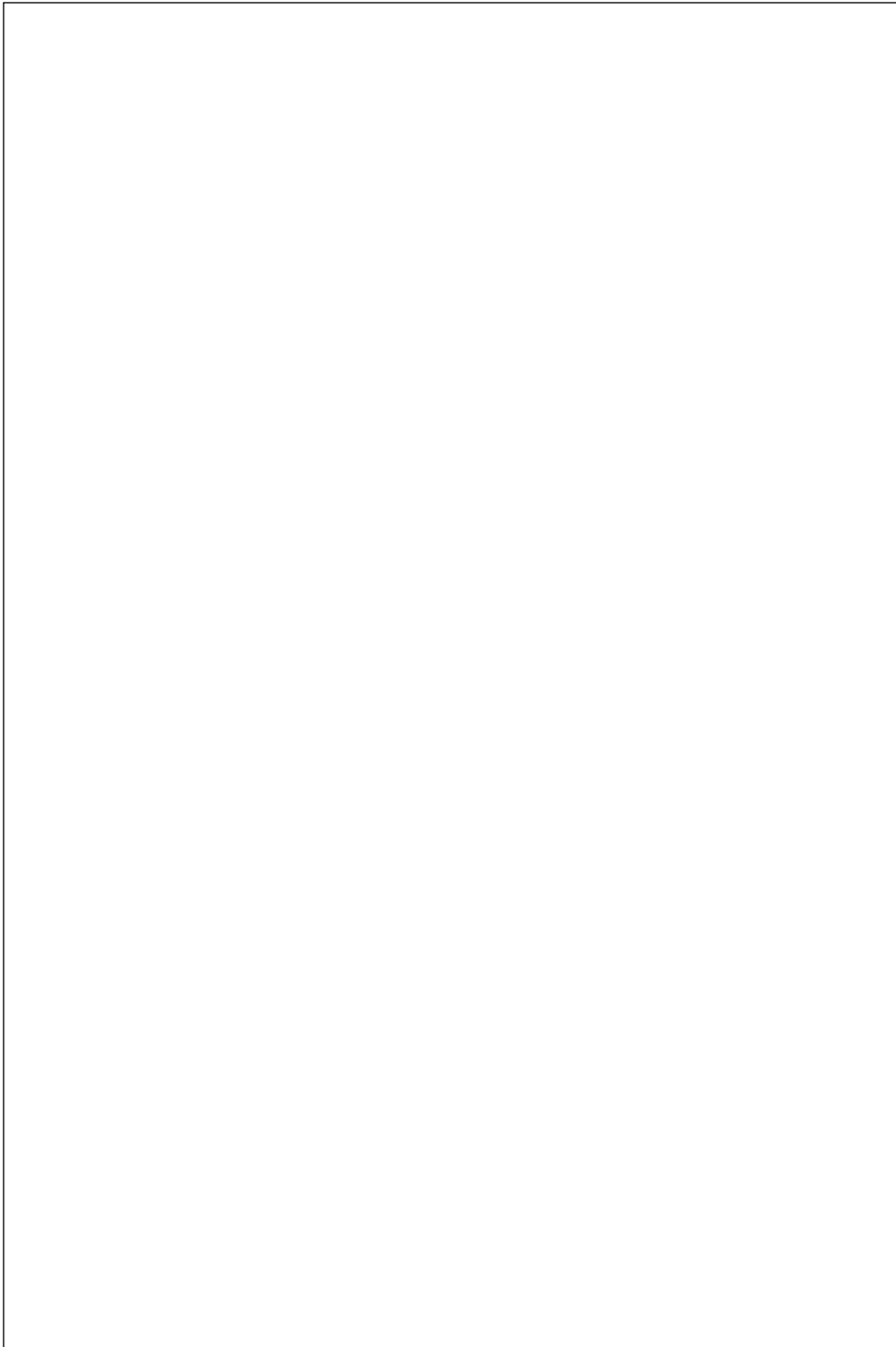

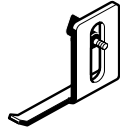

1 608 132 006

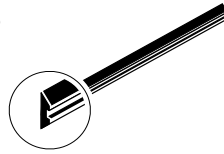

2 608 635 376 (1x)
 2 608 635 350 (2x)

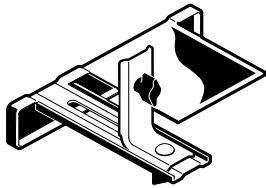

2 607 000 102

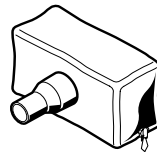

2 605 411 035

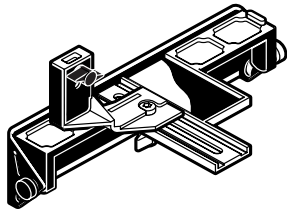

2 607 001 077
 (0 - 45°)



2 605 702 022

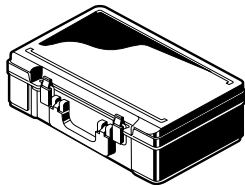

2 605 438 532

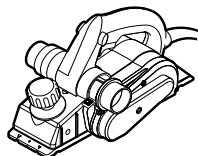
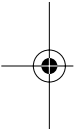

Ø 35 mm
 3 m 2 607 000 837
 5 m 1 609 202 230

GAS ...



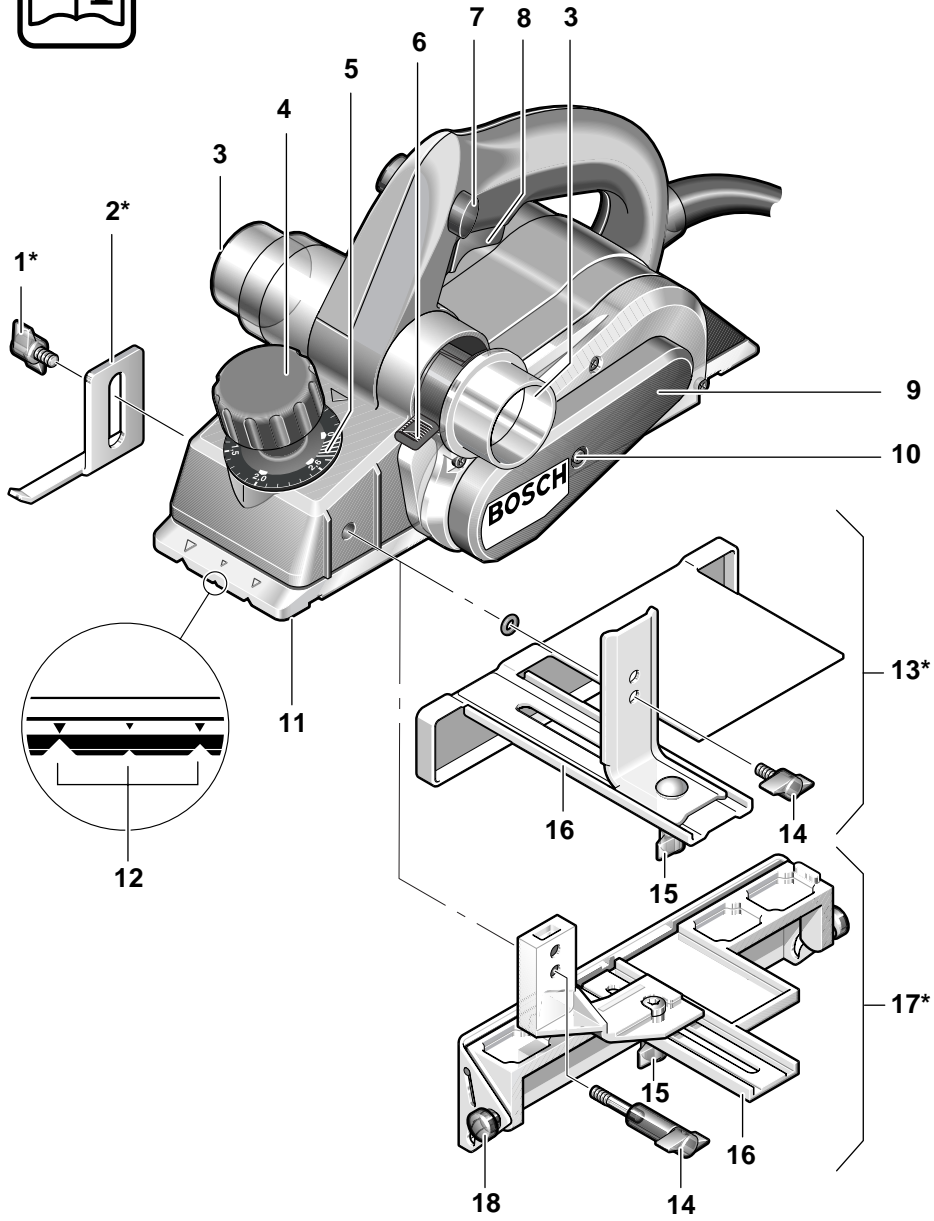

GHO 26-82



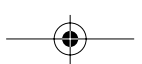
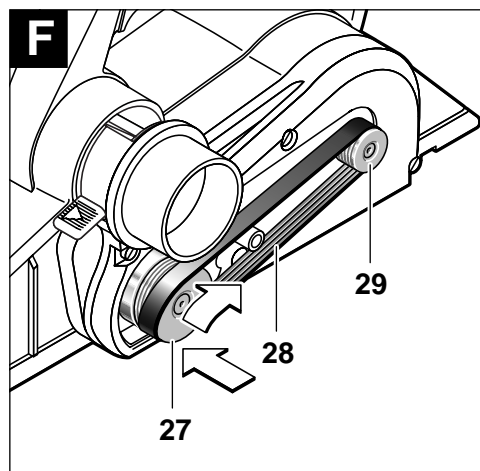
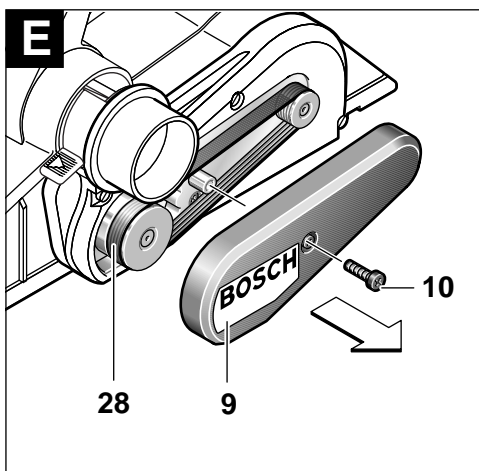
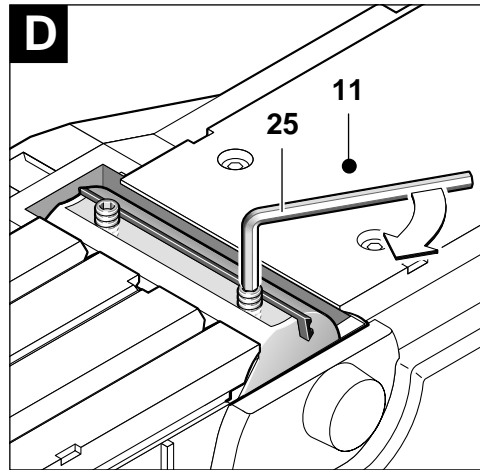
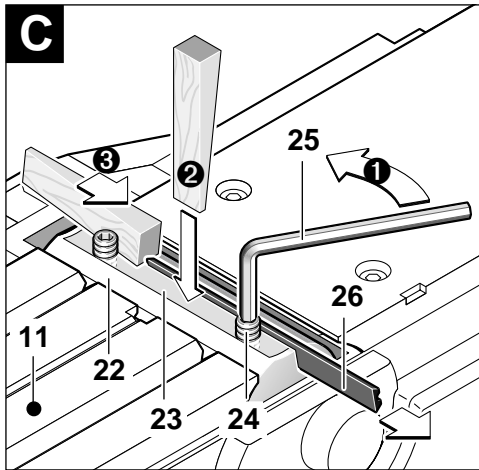
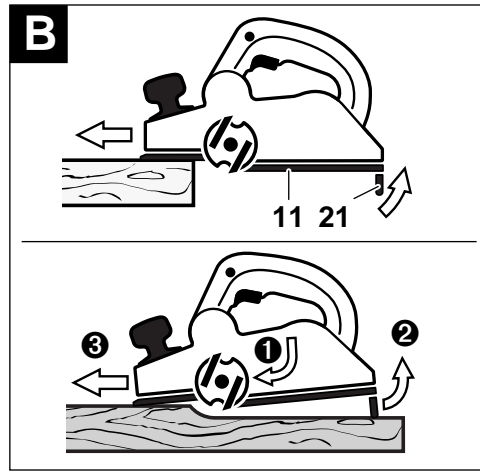
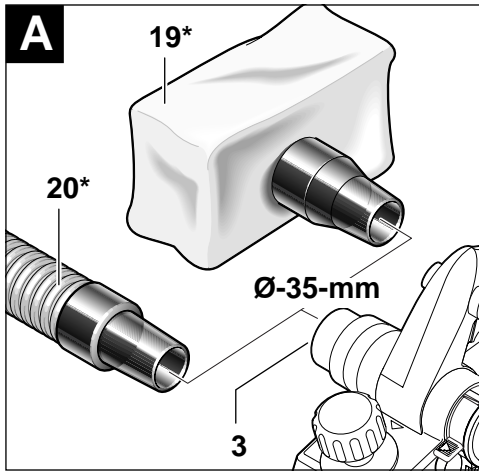

Tool Specifications

Planer	GHO 26-82
Order number	0 601 594 1..
Rated power	[W] 710
Output power	[W] 400
No-load speed	[rpm] 16 500
Planing depth	[mm] 0–2.6
Rebating depth	[mm] 0–9.0
Planer width (max.)	[mm] 82
Weight (without accessories) approx.	[kg] 2.6
Protection class	□ / II

Please observe the order number of your machine.
The trade names of the individual machines may vary.

Machine Elements

- 1 Fastening bolt for rebating depth stop*
- 2 Rebating depth stop*
- 3 Chip ejector (alternatively right/left)
- 4 Adjustment knob for planing depth
- 5 Planing depth scale
- 6 Change-lever for direction of chip ejection
- 7 Switch lock
- 8 On/Off switch
- 9 Belt cover
- 10 Screw for belt cover
- 11 Planer shoe
- 12 V-grooves
- 13 Parallel guide*
- 14 Fastening bolt for parallel and angle guide
- 15 Locking nut for adjustment of rebating width
- 16 Scale for rebating width
- 17 Angle guide*
- 18 Locking nut for angle adjustment
- 19 Dust/wood chip bag with adapter*
- 20 Vacuum hose*
- 21 Blade protector
- 22 Blade head
- 23 Blade-clamping element
- 24 Fastening screws for planer blade
- 25 Allen key
- 26 HM/TC planer blade
- 27 Large belt pulley
- 28 Drive belt
- 29 Small belt pulley

* Not all of the accessories illustrated or described are included as standard delivery.



For Your Safety

Working safely with this machine is possible only when the operating and safety information are read completely and the instructions contained therein are strictly followed. Before using for the first time, ask for a practical demonstration. In addition, the general safety notes in the enclosed booklet must be observed.

- Wear safety glasses, protective gloves and sturdy shoes.
- For long hair, wear hair protection. Work only with closely fitting clothes.
- If the mains cable is damaged or cut through while working, do not touch the cable but immediately pull the mains plug. Never use the machine with a damaged cable.
- Connect machines that are used in the open via a residual current device (RCD) with an actuating current of 30 mA maximum. Use only extension cables that are approved for outdoor use.
- Always direct the cable to the rear away from the machine.
- Apply the machine to the workpiece only when switched on.
- Use only sharp planing blades.
- Always hold the machine firmly when working and ensure a secure stance.
- Keep hands away from rotating parts.
- The planer shoe 11 must lay flat on the surface when working.
- Never plane over metal objects such as nails or screws.
- Do not allow fingers to enter the chip ejector 3.
- Always switch the machine off and wait until it has come to a standstill before placing it down.
- Never allow children to use the machine.
- Bosch is only able to ensure perfect operation of the machine if the original accessories intended for it are used.

Intended Use

The machine is intended for planing of firmly supported wooden materials, such as beams and boards. It is also suitable for beveling edges and rebating.

Initial Operation

Observe correct mains voltage: The voltage of the power source must agree with the voltage specified on the nameplate of the machine. Equipment marked with 230 V can also be connected to 220 V.

Switching On and Off

To **start** the machine, press the safety switch against starting **7 first**, then press and hold the On/Off switch **8**.

To **switch off** the machine, release the On/Off switch **8**.

For safety reasons the On/Off switch of the machine cannot be locked; it must remain pressed during the entire operation.

Adjusting the Planing Depth

The planing depth can be adjusted variably from 0 – 2.6 mm with the adjustment knob **4**, using the planing depth scale **5** (scale graduation = 0.1 mm):

Rotation in **counterclockwise** direction ↶ = **reduces** the planing depth

Rotation in **clockwise** direction ↷ = **increases** the planing depth

Dust/Chip Extraction (see figure **A**)

The dust that is produced while working can be detrimental to health, inflammable or explosive. Suitable safety measures are required.

Examples: Some dusts are regarded as carcinogenic. Use suitable dust/chip extraction and wear a dust respirator.

Clean the chip ejector **3** regularly. Use a suitable tool (e. g. piece of wood, compressed air, etc.) to clean clogged chip ejector. Do not allow fingers to enter the chip ejector **3**.

To ensure optimum extraction of dust/wood chips, attach the vacuum hose **20** or the dust/wood chip bag **19** tightly onto the chip ejector **3**.

External Dust Extraction

The chip ejector **3** fits on both sides for direct connection of the Bosch vacuum hose Ø - 35 mm **20** (accessory). When using other vacuum hose systems a suitable extraction adapter may be required.

The vacuum cleaner must be suitable for the material to be worked.

When vacuuming dry dust that is especially detrimental to health or carcinogenic, use a special vacuum cleaner.

Integrated Dust Extraction

A dust/wood chip bag **19** (accessory) can be used for smaller jobs.

Empty the dust/wood chip bag regularly. Remove the dust/wood chip bag, open the zipper and empty the dust/wood chip bag.

Choice of Chip Ejector Side (Right/Left)

The chip ejector **3** can be switched to the right or left with the change lever **6**.

Always press the change lever until it engages in the end position.

The selected ejector direction is marked with an arrow.

Operating Instructions

Blade Protector (see figure **B**)

The integrated blade protector **21** allows the machine to be set down directly after operation, without danger of damaging the working surface or the planer blade.

When planing, the blade protector **21** is tilted upwards thus enabling full contact of the rear part of the planer shoe **11**.

Planing (see figure B)

Set the required planing depth and place the front part of the planer shoe **11** against the workpiece.

⚠ Caution! Danger of kickback!
Apply the machine to the workpiece only when switched on.

Switch the machine on and guide the machine with an even feed over the surface to be planed.

To achieve high-grade surfaces, work only with low feed and apply pressure on the centre of the planer shoe.

When machining hard materials (e. g. hardwood) as well as when utilising the maximum planer width, set only low planing depths and reduce planer feed, as required. Repeat the planing several times.

Excessive feed reduces the surface quality and can lead to rapid clogging of the chip ejector.

Only sharp blades achieve good cutting capacity and give the machine longer life.

Continuing interrupted planing

The integrated blade protector **21** also allows for continued planing at any given location on the workpiece after an interruption:

- With the blade protector folded down, place the machine on the location of the workpiece where the planing is to be continued.
- Switch the machine on.
- Apply the supporting pressure onto the front part of the planer shoe and slowly push the machine forwards (➔). This tilts the blade protector **21** up (⌚) so that the rear part of the planer shoe **11** faces on the workpiece again.
- Guide the machine alongside the surface to be planed (➔) with an even feed.

Beveling Edges

The V-grooves **12** in the front planer shoe **11** allow quick and easy beveling of workpiece edges. Depending on required bevel width, use the corresponding V-groove.

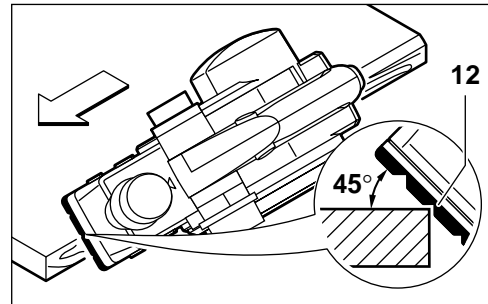

For this, place the planer with the V-groove **12** onto the edge of the workpiece and guide along the edge.

Using the Parallel/Angle Guide (Accessory)

Mount parallel guide **13** or angle guide **17** to the machine using fastening bolt **14** and rebating depth stop **2** using fastening bolt **1**.

Loosen locking nut **15** and adjust the required rebating width with the scale **16**. Retighten locking nut **15** again.

Adjust the required rebating depth accordingly with the rebating depth stop **2**.

Carry out the planing procedure several times, until the required rebating depth is reached. Pay attention that the planer is guided with sideward supporting pressure.

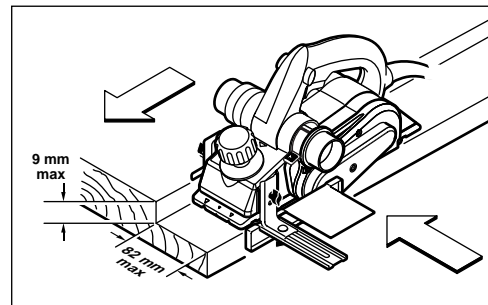

Beveling (only angle guide 17)

When beveling rebates and surfaces, adjust the required slope angle with the angle adjustment **18**.

Replacing the Planer Blade (HM/TC)

- Before any work on the machine itself, pull the mains plug.
- Be cautious when replacing the planer blades: Possible danger of injury due to the sharp cutting edges of the planer blades! Do not grasp the planer blades by the cutting edges.
- Use only original Bosch HM/TC planer blades.

The carbide planer blade (HM/TC) has 2 cutting edges and can be reversed.

When both cutting edges are dull, the planer blade must be replaced. The HM/TC planer blade may not be resharpened.

Disassembling the Planer Blades (see figure C)

To reverse or replace the planer blade, rotate the blade head 22 until it is parallel to the planer shoe 11.

- 1 Loosen the two fastening screws 24 with the Allen key 25 by approx. 1–2 turns.
- 2 If necessary, loosen the blade-clamping element 23 by giving it a light blow with a suitable tool (e. g. a wooden wedge).
- 3 Push the planer blade 26 sideways out of the blade head with a piece of wood.

Assembling the Planer Blades (see figure D)

The guide groove of the planer blade always ensures continuous height adjustment when replacing or reversing it.

Clean the blade seat (clamping element) and the planer blade respectively, if required.

When assembling the planer blade, ensure that it is seated properly in the blade holder of the clamping element 23.

The planing blade must be assembled and aligned **centrally to the planer shoe**.

Afterwards tighten the fastening screws 24 again.

- Before restarting, check if the clamping screws 24 are tightened well.
- Rotate the blade head 22 by hand and ensure that the planer blade does not run into the planer shoe or housing.

Replacing the Drive Belt

- Before any work on the machine itself, pull the mains plug.

Loosen screw 10 and take off the belt cover 9. Remove worn drive belt 28. (see figure E)

Before assembling a new drive belt, clean both belt pulleys 27 and 29. Place the new drive belt on the small belt pulley 29 first and then work it on the large belt pulley 27 by hand while rotating. (see figure F)

Take care that the drive belt runs exactly in the length grooves of the drive gear and the pulley.

Reattach the belt cover 9 and tighten with the screw 10.

Maintenance and Cleaning

- Before any work on the machine itself, pull the mains plug.
- For safe and proper working, always keep the machine and the ventilation slots clean.

Clean the blade protector 21 regularly and ensure that it runs free.

When the carbon brushes are worn out, the machine switches itself off. The machine must be sent to customer service for maintenance (for address, see the "Service and Customer Assistance" section).

If the machine should fail despite the care taken in manufacturing and testing procedures, repair should be carried out by an after-sales service centre for Bosch power tools.

In all correspondence and spare parts orders, please always include the 10-digit order number given on the nameplate of the machine.

WARNING! Important instructions for connecting a new 3-pin plug to the 2 wire cable.

The wires in the cable are coloured according to the following code:

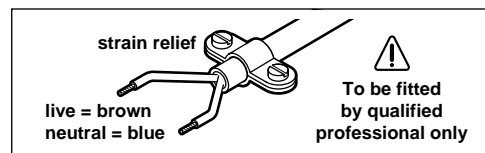

Do **not** connect the blue or brown wire to the earth terminal of the plug.

Important: If for any reason the moulded plug is removed from the cable of this machine it must be disposed of safely.



Environmental Protection



Recycle raw materials instead of disposing as waste

The machine, accessories and packaging should be sorted for environmental-friendly recycling.

These instructions are printed on recycled paper manufactured without chlorine.

The plastic components are labelled for categorized recycling.

Noise/Vibration Information

Measured values determined according to EN 50 144.

Typically the A-weighted sound pressure level of the product is 84 dB (A).

The noise level when working can exceed 85 dB (A).

Wear hearing protection!

The typical hand/arm vibration is below 2.5 m/s².

Service and Customer Assistance

Great Britain

Robert Bosch Ltd. (B.S.C.)
P.O. Box 98
Broadwater Park
North Orbital Road
Denham-Uxbridge
GB-Middlesex UB 9 5HJ

☎ Service..... +44 (0) 18 95 / 83 87 82

☎ Advice line..... +44 (0) 18 95 / 83 87 91

Fax..... +44 (0) 18 95 / 83 87 89

Ireland

Beaver Distribution Ltd.
Greenhills Road
IRL-Tallaght-Dublin 24

☎ Service..... +353 (0)1 / 414 9400

Fax..... +353 (0)1 / 459 8030

Australia

Robert Bosch Australia L.t.d.
RBAU/SPT2
1555 Centre Road
P.O. Box 66 Clayton
AUS-3168 Clayton/Victoria

☎ +61 (0)1 / 800 804 777

Fax..... +61 (0)1 / 800 819 520

www.bosch.com.au

E-Mail: CustomerSupportSPT@au.bosch.com

New Zealand

Robert Bosch Limited
14-16 Constellation Drive
Mairangi Bay
Auckland
New Zealand

☎ +64 (0)9 / 47 86 158

Fax..... +64 (0)9 / 47 82 914

CE Declaration of Conformity

We declare under our sole responsibility that this product is in conformity with the following standards or standardization documents: EN 50 144 according to the provisions of the directives 89/336/EEC, 98/37/EC.

Dr. Gerhard Felten

Dr. Eckerhard Strötgen

ppa. Felten i.v. Strötgen

Robert Bosch GmbH, Geschäftsbereich Elektrowerkzeuge

Subject to change without notice

